

# LD-MRS Laser Scanner



Multi-layer scanner for harsh  
environmental conditions



**Software version described**

Software/tool	Function	Status
Device description LD-MRS	Device specific software module for SOPAS ET	
SOPAS ET	Configuration software	V 02.18 or higher

## Abbreviations

<b>CAN</b>	Controller area network = standardized fieldbus system with message-based protocol for exchanging data
<b>EEPROM</b>	Electrically erasable programmable read-only memory
<b>HTML</b>	Hypertext markup language = page description language on the Internet
<b>LD</b>	Ladar Digital (Ladar = laser radar)
<b>MRS</b>	Multi-Layer Range Scanner = scanner for large scanning ranges on several layers
<b>RAM</b>	Random access memory = volatile memory with direct access
<b>SOPAS ET</b>	SICK OPEN PORTAL for APPLICATION and SYSTEMS ENGINEERING TOOL = configuration software for the configuration of the LD-MRS

# 1 Configuration (parameterization)

The laser measurement sensor is adapted to the on-site measurement situation by means of the configuration. You can configure and test the measurement properties, the analysis behaviour and the output properties of the sensor as required.

## NOTICE

### Don't switch off the voltage supply during configuration!

Switching off the voltage supply during configuration causes all parameters already configured to be lost.

### Password protection of the LD-MRS

Software access to the LD-MRS is password protected. The default factory setting for the password is as follows:

User level	Password
Authorized client	client

Tab. 1: Passwords of the LD-MRS

### How to login to the LD-MRS:



1. From the TOOLS menu select the LOGIN DEVICE command.
2. In the LOGIN dialogue, select the USER LEVEL and enter the PASSWORD.

### Save parameters permanently

The data are initially saved in the RAM of the LD-MRS so that you can check the effect immediately. On completion of the configuration, you must save the parameters in non-volatile memory, that is in the EEPROM in the LD-MRS.

### How to save the parameters permanently in the LD-MRS:



- Click the SAVE PARAMETERS IN THE DEVICE button on the toolbar.  
In this way the parameters are saved in the EEPROM of the LD-MRS and will also be available after the device is switched off and on again.

### Save configuration

The configuration data can be saved in a project file so they can be transferred, for example, to an identical LD-MRS. Additionally, you can save the configuration data as PDF.

### How to save the configuration data to a file or as PDF:



1. From the PROJECT menu, choose the command SAVE PROJECT.
2. From the PROJECT menu, choose the command PRINT, SAVE AS PDF.

### Resetting configuration

You can reset the LD-MRS to the default delivery status. During this process, all parameters configured previously are lost.

**Recommendation** Save the configuration data in a project file prior to resetting the configuration.



#### How to reset the configuration of the LD-MRS:

1. On the LD-MRS [NAME OF THE LD-MRS] menu, choose the RESET TO FACTORY SETTINGS command.
2. In answer to the subsequent warning, click OK if you are sure you want to overwrite all the parameters previously configured.  
The parameters for the LD-MRS are overwritten with the parameters from the default delivery status.  
A message appears that the factory settings have been set and the LD-MRS has been restarted.  
The old data can then **still** be seen in the SOPAS ET user interface.
3. Please wait approx. 20 seconds.
4. From the COMMUNICATION menu, choose the command SWITCH ONLINE.  
In answer to the prompt as to whether you want to load the data from the LD-MRS to SOPAS ET, click YES.  
The factory settings can then be seen in the SOPAS ET user interface.

## 1.1 Basic parameters

### 1.1.1 Current configuration

The CURRENT CONFIGURATION area indicates the currently set scanning frequency and angular resolution.

**Important** Values are only displayed if you configure a device online, that is the PC is connected to the device.

#### How to display the current device parameters:



- In the PROJECT TREE, LD-MRS (NAME), PARAMETER, open the device page BASIC PARAMETER.  
The CURRENT CONFIGURATION area indicates the currently set SCAN FREQUENCY and ANGULAR RESOLUTION.

### 1.1.2 New configuration

In the NEW CONFIGURATION area you can configure the scanning frequency and the angular resolution and transfer these parameters to the LD-MRS.

#### Scanning frequency

The LD-MRS scans with a scanning frequency of 12.5, 25 or 50 Hz. At the higher scanning frequency the LD-MRS supplies more measured values per time unit.

#### Angular resolution

The LD-MRS scans with an angular resolution of 0.25° or 0.50°. At the finer angular resolution, the LD-MRS supplies more measured values per scan.

**Important** The LD-MRS has four scan planes (layers). Each of the four layers on the LD-MRS is measured and evaluated simultaneously. If, e.g., an angular resolution of  $0.25^\circ$  is configured, this means that between the two layers (e.g. red-blue) and their partners (e.g. yellow-green) there is an angular step of  $0.25^\circ$ . The angle to the next measurement on the same plane is twice that, in this example  $0.50^\circ$ .

The available angular resolutions are dependent on the scanning frequency. There are the following valid combinations of scanning frequency and angular resolution:

- 12.5 Hz and  $0.25^\circ$
- 25 Hz and  $0.25^\circ$
- 50 Hz and  $0.50^\circ$

After the transfer of the values the LD-MRS may return an error value to SOPAS ET in certain circumstances. This situation has the following possible meanings:

- No error, parameters have been accepted by the LD-MRS
- Invalid combination
- If "Invalid combination" is returned, then check the scanning frequency or/and angular resolution entry.

#### Starting angle and stopping angle of the scan area

The LD-MRS can scan a maximum scan area of  $110^\circ$ .

- The starting angle is  $-60^\circ$ .
- The stopping angle is  $+50^\circ$ .

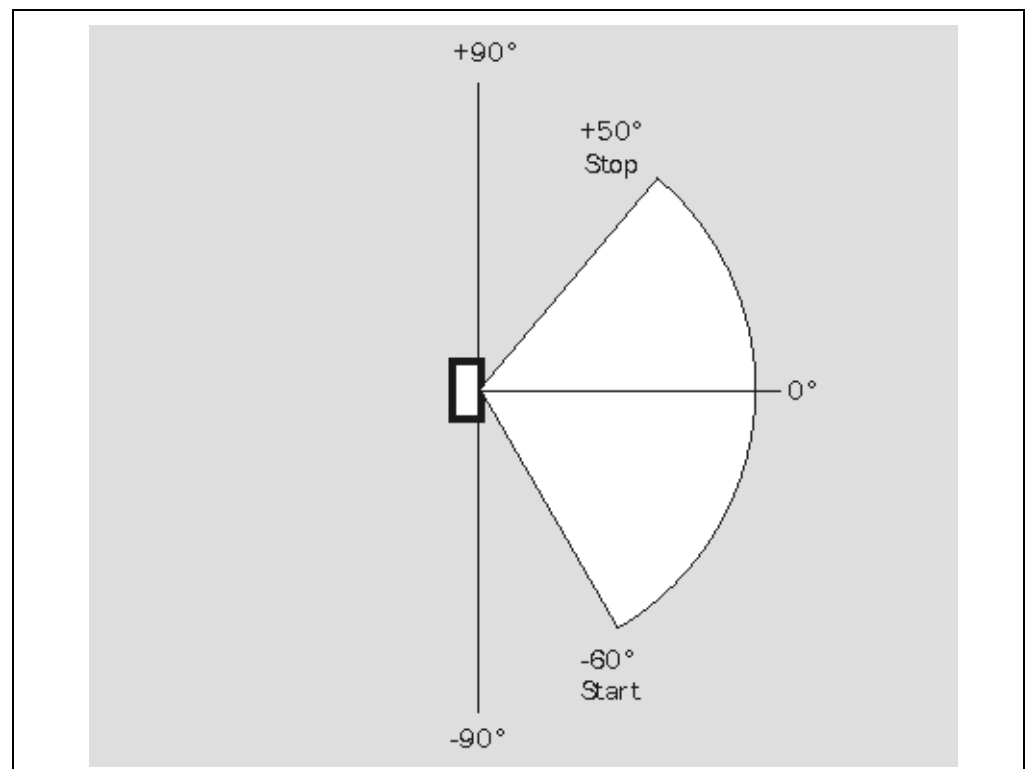

Fig. 1: Starting angle and stopping angle for the measurement

The figure shows the scan area with starting angle and stopping angle.

Objects outside the scan area are not measured or detected. Evaluation fields can only be configured within the scan area (see [section 1.3.6 "Setting end points for a segmented evaluation field" on page 13](#)).

**How to change the device parameters:**

1. In the PROJECT TREE, LD-MRS (NAME), PARAMETER, open the device page BASIC PARAMETER.
2. Enter the new parameters in the NEW CONFIGURATION area and click the TRANSFER button.  
The parameters are transferred to the LD-MRS, the result of the transfer is displayed in the RETURN VALUE field.

**1.1.3 Measurement**

You can start the LD-MRS measurement manually.

**How to start and stop the measurement:**

1. In the PROJECT TREE, LD-MRS (NAME), PARAMETER, open the device page BASIC PARAMETER.
2. In the MEASUREMENT area, click the START button.  
The measurement will be started.
3. In the MEASUREMENT area, click the STOP button.  
The measurement will be stopped.

**1.2 Filters****Interference filter**

The interference filter reduces the effects of atmospheric interference such as rain, spray or dust using the so-called clutter filter. This filter classifies the scan data and differentiates between normal measured values and interference.

The filter acts both on the field evaluation and on the output of the measured data.

The LD-MRS has four scan planes (layers). Every second measurement within a layer is made in the near range up to approx. 15 metres with reduced sensitivity. For larger distances, the measurement is made with normal sensitivity. The measured data are also evaluated. During this process criteria such as relationships between neighboring measurements with normal and reduced sensitivity as well as the measurement characteristic of the sensor are taken into account.

Measured values identified as clutter are not transmitted to the SOPAS-ET interface.

**Important** The sensitivity in the near range is reduced by the clutter filter. As a result targets with lower remission are more difficult for the LD-MRS to detect.

### Only last echo

With this filter only the last echo from a laser pulse is measured. If, for example, part of the energy is reflected as a first or second echo by a pane of glass or a rain droplet, only the last echo from the actual object is measured. The filter acts both on the field evaluation and on the output of the measured data.

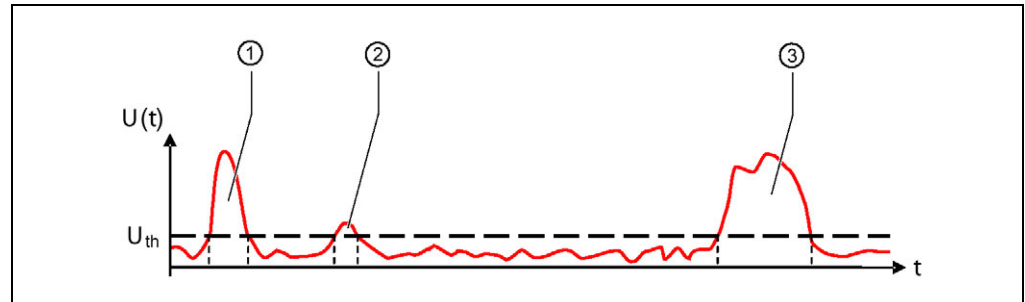

Fig. 2: Example of three echos from a laser pulse

(1) Echo from a pane of glass, (2) echo from a rain droplet and (3) echo from an object

### How to configure the filters:

1. In the PROJECT TREE, LD-MRS (NAME), PARAMETER, BASIC PARAMETER, open the device page FILTER.
2. Activate the required filter in the GENERAL FILTER area.









### 1.3 Evaluation fields

With the aid of the field application integrated into the LD-MRS, up to 16 evaluation fields can be configured. The existing evaluation fields are displayed in a table in the EVALUATION FIELDS OVERVIEW area.

The table shows along with the number and name of the related evaluation field, the evaluation case to which the evaluation field is linked.

You can run the following functions using the buttons above the table:

Symbol	Meaning	Comment
	Create evaluation field	Using this button you can create a new evaluation field. The dialog box for adding a new evaluation field is opened (see <a href="#">1.3.1 on page 9</a> ).
	Edit evaluation field	You can edit an existing evaluation field using this button. ➤ For this purpose mark one of the evaluation fields in the table and then click the button.
	Copy evaluation field	You can copy an existing evaluation field using this button. During this process, all parameters in the existing field are copied to the new field. ➤ For this purpose mark one of the evaluation fields in the table and then click the button.
	Delete evaluation field	You can delete an existing evaluation field using this button. ➤ For this purpose mark one of the evaluation fields in the table and then click the button.  An evaluation case in which the evaluation field is used is invalid (see <a href="#">2.1 on page 28</a> )!

Tab. 2: Buttons for managing the evaluation fields

#### How to configure the fields of the LD-MRS:



- In the PROJECT TREE, LD-MRS (NAME), PARAMETER, open the device page EVALUATION FIELDS. In the EVALUATION FIELDS OVERVIEW area you can create, copy, edit or delete fields.

#### 1.3.1 Basic parameters for the evaluation fields

First you define the name of the evaluation field and its type. The type determines how you draw or create the evaluation field in the field editor.

- Segmented  
The evaluation field is added in segments. For this purpose set each separate point for the field using the mouse (see [section 1.3.6 "Setting end points for a segmented evaluation field" on page 13](#)).

**Important**

If you have selected the SEGMENTED option an evaluation field can also be taught-in.

- Rectangular  
It is only possible to add rectangular evaluation fields. Enter the coordinates of the field (see [section 1.3.8 "Creating and editing a rectangular evaluation field" on page 16](#)).

### 1.3.2 Using the field editor

Using the field editor you can ...

- create an evaluation field manually using the drawing tools. You have several ways of undertaking this action, see:
  - [section 1.3.6 "Setting end points for a segmented evaluation field" on page 13](#)
  - [section 1.3.7 "Setting start points for a segmented evaluation field" on page 15](#)
  - [section 1.3.8 "Creating and editing a rectangular evaluation field" on page 16](#)
- teach-in an evaluation field with the aid of the LD-MRS (see [section 1.3.9 "Teaching-in an evaluation field" on page 18](#)).
- teach-in the reference contour for an evaluation field (see [section 1.3.10 "Defining reference contour" on page 21](#)).

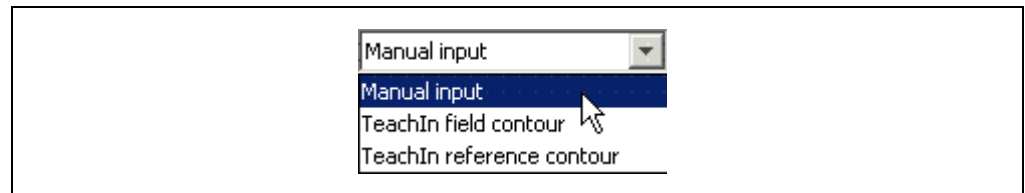

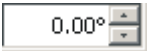



Fig. 3: Selection of the method for creating a segmented evaluation field

### 1.3.3 Adapting the field editor view

To be able to work optimally with the field editor, you can change the screen layout.

Symbol	Meaning	Comment
	Zoom in/zoom out	Using these buttons you can make the following changes to the view: <ul style="list-style-type: none"> <li>• Zoom in</li> <li>• Zoom out</li> <li>• Zoom in/zoom out on all active points of the field or the scanned contour</li> <li>• Zoom in/zoom out on the maximum field of view of the LD-MRS</li> </ul>
	Rotate view	You can rotate the field editor view using the input field or the buttons beside the input field. In this way you can change the view, for example, to suit your application. <ul style="list-style-type: none"> <li>➤ Enter the angle of rotation for the view in the input field.</li> <li>Or</li> <li>➤ Change the angle of rotation of the view in steps using the arrow buttons beside the field on the right.</li> </ul>
	Change coordinate system/mirror view	Using these buttons you can make the following changes to the view: <ul style="list-style-type: none"> <li>• Change between Cartesian and polar view</li> <li>• Mirror the view on the LD-MRS, i.e. you no longer see the LD-MRS from above, but from below.</li> </ul>
	Show	<ul style="list-style-type: none"> <li>• Show scan line of the LD-MRS</li> <li>• Display measurement contour as a line or as individual points</li> <li>• Show other fields, you can then see the existing fields as a contour.</li> </ul>

Tab. 3: Buttons for changing the field editor view

In addition you can zoom in by dragging a rectangle around the objects on which you want to zoom.

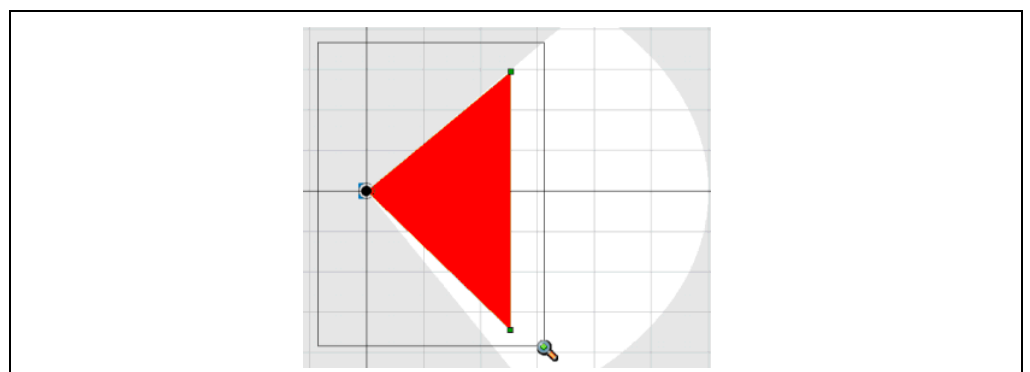

Fig. 4: Enlarging the field editor view with the mouse

### 1.3.4 Showing or hiding layers and echos

With the aid of the matrix on the bottom right in the field editor, you can show or hide the individual layers and the echos that are measured in the individual layers.

**Important** Showing or hiding only has an effect on the display of data in the field editor, not on the function of the field.

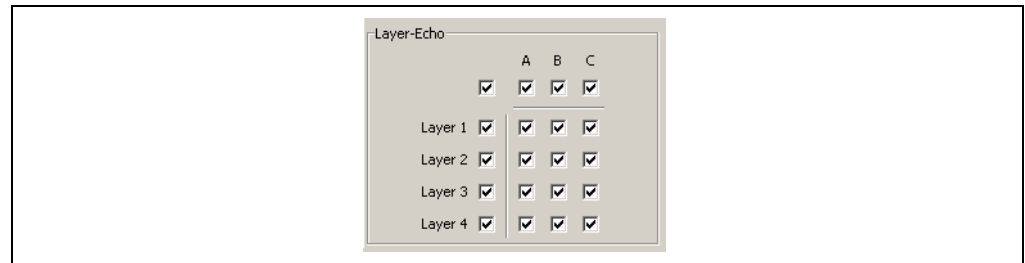

Fig. 5: Showing or hiding layers and echos

#### Horizontal rows: Showing or hiding echos in a layer

If the laser beam is incident on a pane of glass or a rain droplet, only part of the energy will be reflected. As a result several echos are possible. The LD-MRS can measure a maximum of three echos.

#### Vertical rows: Hide or show layer

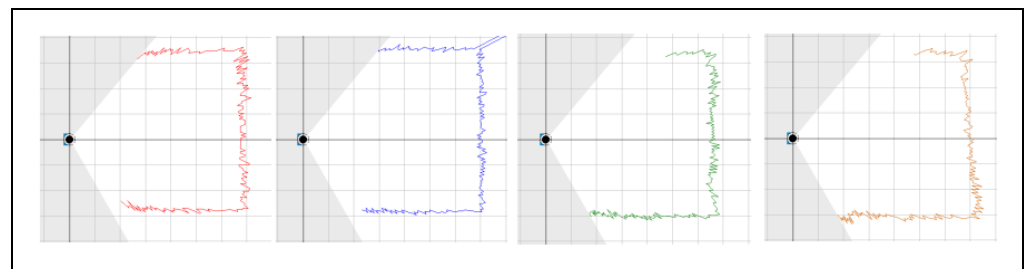

Fig. 6: Layer colors

Layer 1 = red

Layer 2 = blue

Layer 3 = green

Layer 4 = yellow

### 1.3.5 Defining layers for the evaluation

The LD-MRS has four scan planes (layers). You can configure that all the layers or only certain layers are used for the evaluation.

From the factory all layers are used for the evaluation.

#### How to limit the evaluation to specific layers:

1. Select the LAYER FILTER ACTIVE option.  
The Layer 1 to Layer 4 checkboxes become active.  
I.e., initially **no** layer is used for the evaluation.
2. Select the layers that are to be used for the evaluation.  
If you select several layers, they will be linked with a logical OR.

In the example only layers 3 and 4 are used for the field evaluation. In the figure on the left, although layers 1 and 2 (red and blue) are infringed, the evaluation field still remains green (the allocated output is not switched). In the figure on the right, layers 3 and 4 are also infringed, as a result the evaluation field changes to yellow.

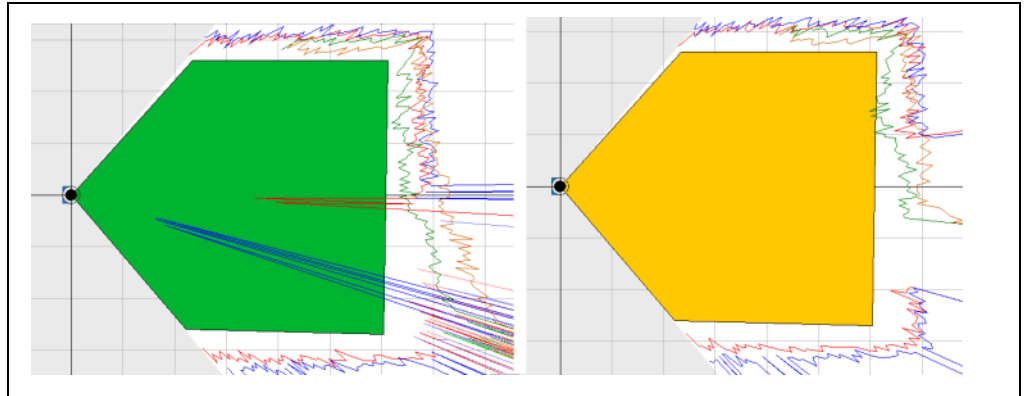

Fig. 7: Restricting the evaluation to specific layers

**1.3.6 Setting end points for a segmented evaluation field**

For a segmented evaluation field, first set the end points that represent the outer limits. The evaluation field starts right at the laser measurement sensor. If the evaluation field is only to start a certain distance from the laser measurement sensor, start points must be set (see [section 1.3.7 "Setting start points for a segmented evaluation field" on page 15](#)).

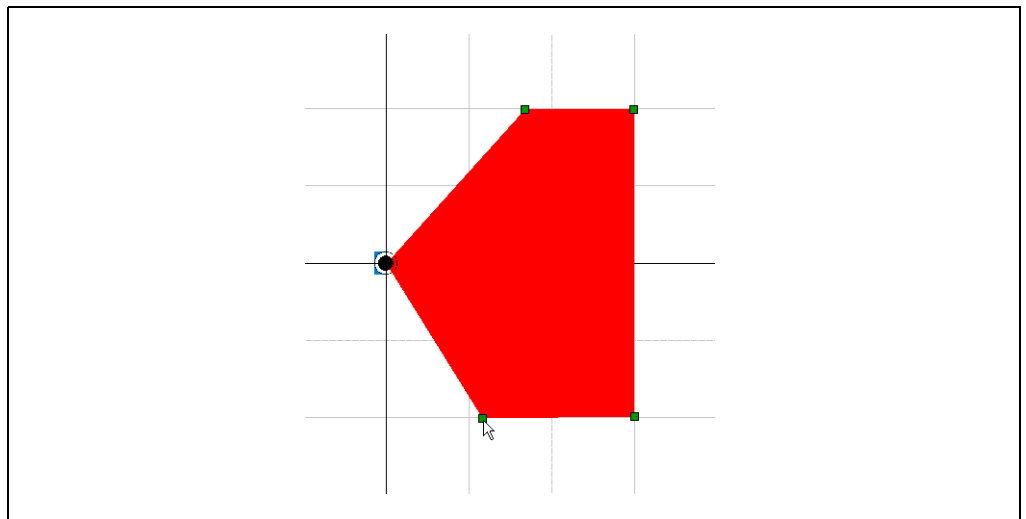

Fig. 8: End points for a field

**How to set end points:**

Fig. 9: Setting end points



1. On the toolbar click the symbol shown.
2. Move the mouse pointer over the co-ordinate field in the field editor.  
The possible point is displayed in yellow.  
**Important:** You can only set points in the measurement area of the LD-MRS.
3. Click the position where you want to set the point.  
The point set is displayed as a green square.
4. Move the mouse pointer to the next point on the field.  
The field you are creating is displayed in yellow.
5. Click the position where you want to set the point.  
The resulting field is shown in red.
6. Complete the field by setting further points.

**Explanation**

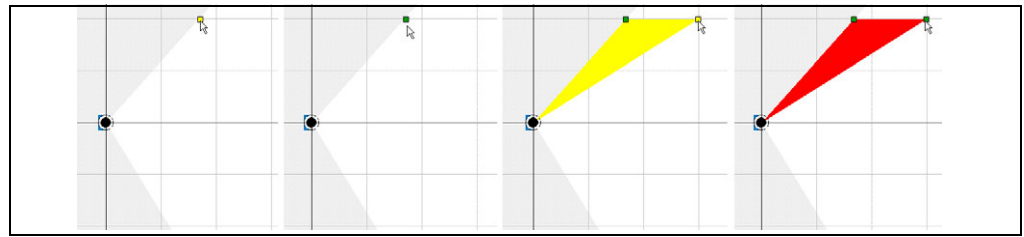
- The coordinates of the mouse pointer are shown in the fields in the COORDINATE area.
- The coordinates of the points set are shown in the FIELD POINTS area.

**How to move end points:**

You can move one end point individually or several end points at the same time.

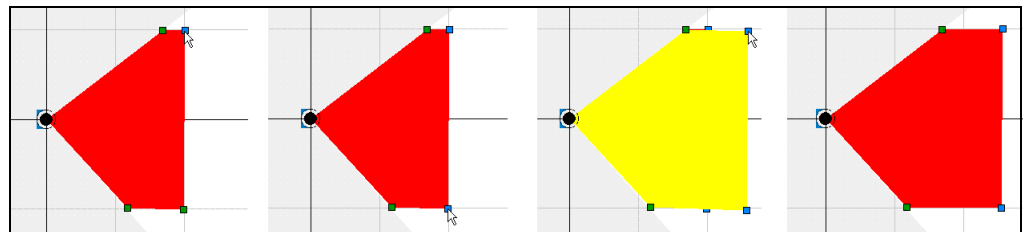

Fig. 10: Moving end points



1. On the toolbar click the symbol shown.
2. Click one of the points for the evaluation field.  
Or:  
Keep the **[Ctrl]** key pressed and click further required points for the evaluation field.  
Or:  
Drag a rectangle around the required points of the evaluation field using the mouse.  
The activated points are marked in blue.
3. Keep the left mouse button pressed and move the point or points. The field you are creating is displayed in yellow.  
Release the left mouse button at the position where you want to position the points. The new field now produced is again shown in red.  
Or:  
Move the points of the evaluation field up, down, right or left using the arrow keys. The field you are creating is displayed in yellow.  
Press the Return key. The field now produced is again shown in red.

**How to delete end points:**

You can delete one end point individually or several end points at the same time.

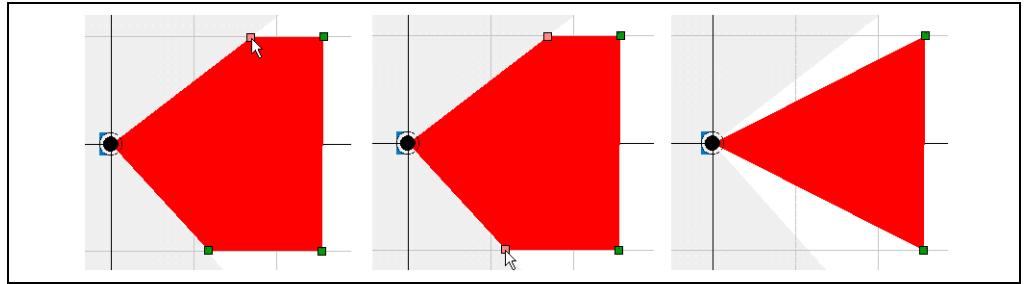

Fig. 11: Deleting end points



1. On the toolbar click the symbol shown.
2. Double-click one of the points for the evaluation field.  
The point is deleted.  
Or:  
Keep the `[Ctrl]` key pressed and click further points of the evaluation field.  
Or:  
Drag a rectangle around the required points of the evaluation field using the mouse.  
The points are marked in red.
3. Press the `[Del]` key.  
The points are deleted.

**1.3.7 Setting start points for a segmented evaluation field**

By setting start points you can implement fields that only start a certain distance from the laser measurement sensor. Using such fields it is, for instance, possible, to walk or drive through the area between the laser measurement sensor and the evaluation field.

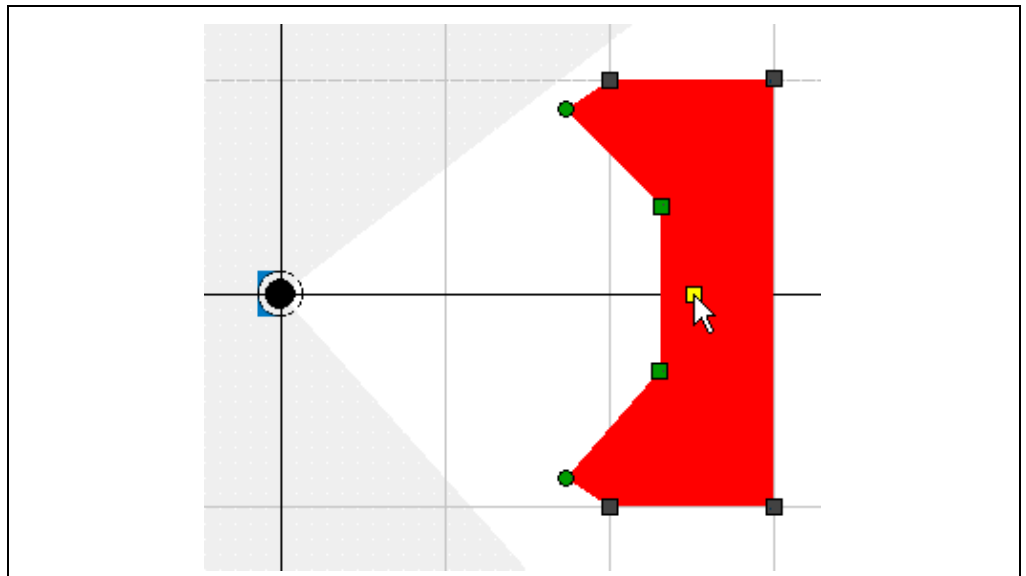

Fig. 12: Start points for an evaluation field

When start points are set, the field editor may set points that are required for physical reasons in certain circumstances. You can move or delete these points like any others.

- The points that you have set using the mouse are shown as squares.
- The points that have been set automatically are shown as circles.

**Important** If you delete a start point, then the related end point will also be deleted in some circumstances.

### 1.3.8 Creating and editing a rectangular evaluation field

If, during the selection of the basic parameters you selected the RECTANGLE option (see [section 1.3.1 "Basic parameters for the evaluation fields" on page 9](#)), then there is already a rectangular field in the field editor. You can move, increase and reduce in size, and rotate this field.

For a rectangular evaluation field you can define the following parameters:

- Position
- Angle of rotation
- Width
- Length

**Recommendation** The field already added is only 2 m wide and 1 m long.



- To make it easier to edit the field, click the symbol shown on the toolbar. The view is zoomed onto the field and the scanner.

#### How to move a rectangular evaluation field:

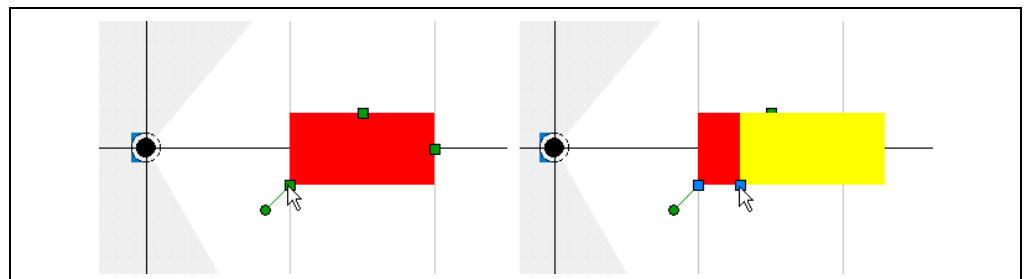

Fig. 13: Moving a rectangular evaluation field



1. On the toolbar click the symbol shown.
2. Click the bottom left point of the field. The point changes to blue.
3. Keep the left mouse button pressed and move the field. During the movement the field is shown in yellow. As soon as you release the left mouse button, the field is shown in red again.



**How to increase or reduce the size of a rectangular evaluation field:**

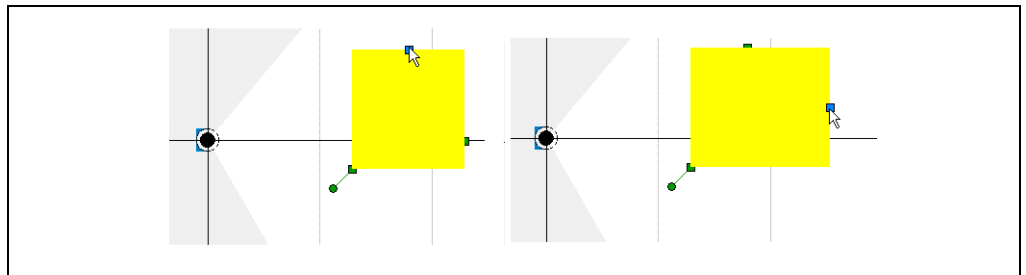

Fig. 14: Increasing or reducing the size of a rectangular evaluation field



1. On the toolbar click the symbol shown.
2. Click the top point or the right point for the field.  
The point changes to blue.
3. Keep the left mouse button pressed and drag to increase or to reduce the size of the field.  
During the movement the field is shown in yellow. As soon as you release the left mouse button, the field is shown in red again.

**How to rotate a rectangular evaluation field:**

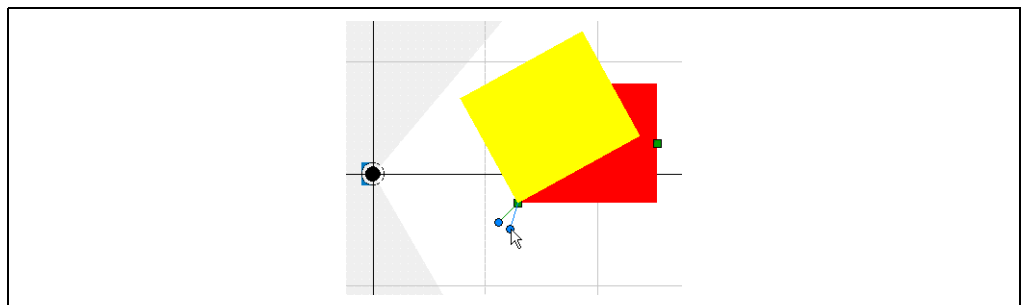

Fig. 15: Rotating a rectangular evaluation field



1. On the toolbar click the symbol shown.
2. Click the round point at the bottom left of the rectangular evaluation field.  
The point changes to blue.
3. Keep the left mouse button pressed and rotate the field about the bottom left corner point.  
During the movement the field is shown in yellow. As soon as you release the left mouse button, the field is shown in red again.

**How to change the evaluation field by making entries:**

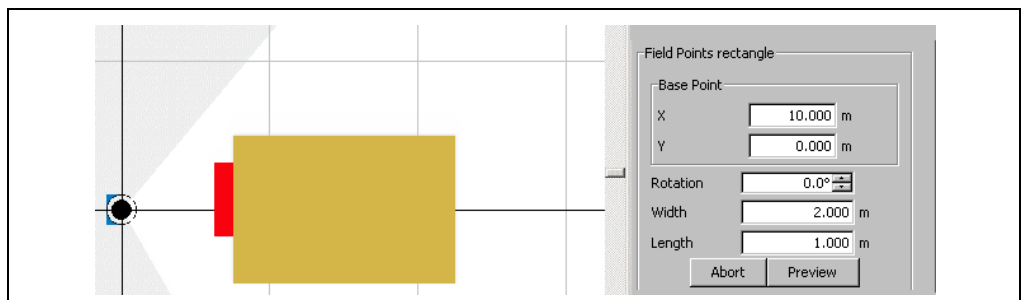

Fig. 16: Editing entries for rectangular evaluation field

1. In the FIELD POINTS RECTANGLE area click the EDIT button.  
You can now edit the fields in the FIELD POINTS RECTANGLE area.
2. In the BASE POINT area, enter the X and Y coordinates for the bottom left point of the evaluation field.
3. Enter the angle of rotation in degrees (°) in the ROTATION field.
4. Enter the dimensions of the evaluation field in the WIDTH and LENGTH fields.
5. Click the PREVIEW button.  
The new evaluation field is displayed in yellow.  
The CHECK ENTRIES dialog box is opened.
6. In the CHECK ENTRIES dialog box, click the YES button.  
The changes are applied and the evaluation field is displayed in red.  
Or:  
In the CHECK ENTRIES dialog box, click the No button.  
The previous field is displayed again.

### 1.3.9 Teaching-in an evaluation field

**Important** An evaluation field can only be taught-in if you have selected the SEGMENTED option in the basic parameters for the field.

To teach-in an evaluation field, the laser measurement sensor scans the visible room contour several times. From the data obtained SOPAS ET determines the contour of the field.

**Recommendation** Show the scan line for the LD-MRS in the field editor. You can then see the scanned contour (1) and use it to orientate yourself.

You can define the first angle (2) and the last angle (3) used during teach-in and therefore pre-define the size of the field. The field you are creating is displayed in yellow.

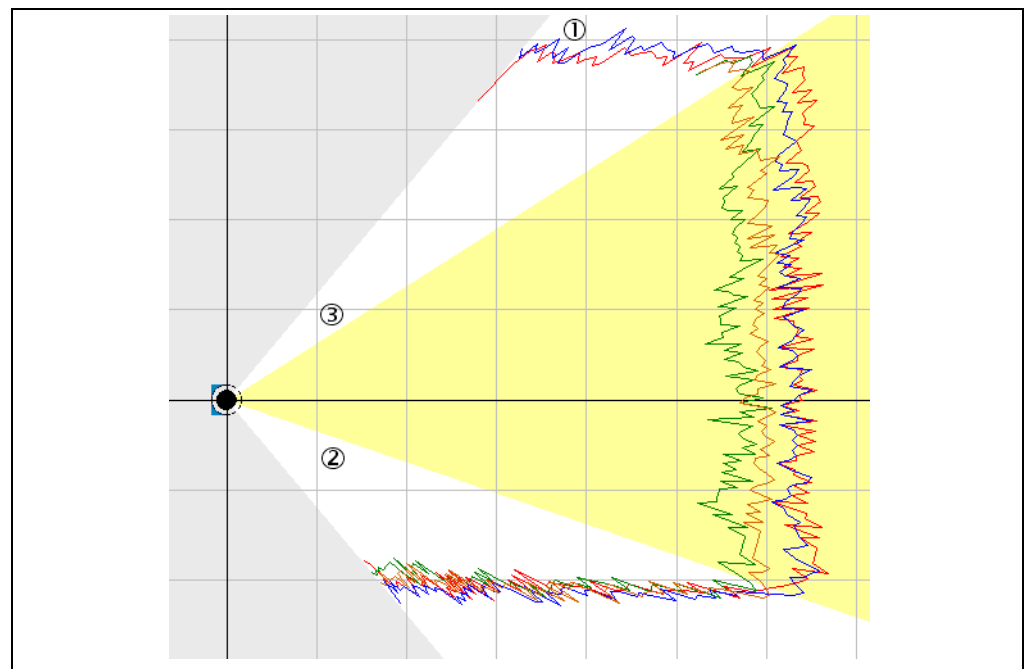

Fig. 17: First angle and last angle for teaching-in an evaluation field

In addition you must define the distance to the scanned contour. The distance should be at least 100 mm (3.94 in), otherwise the evaluation field may be infringed in certain circumstances.

With the distance you define the radial distance for each end point from the scanned contour. If a wall is scanned in front of the LD-MRS, the evaluation field is taught-in with a curve.

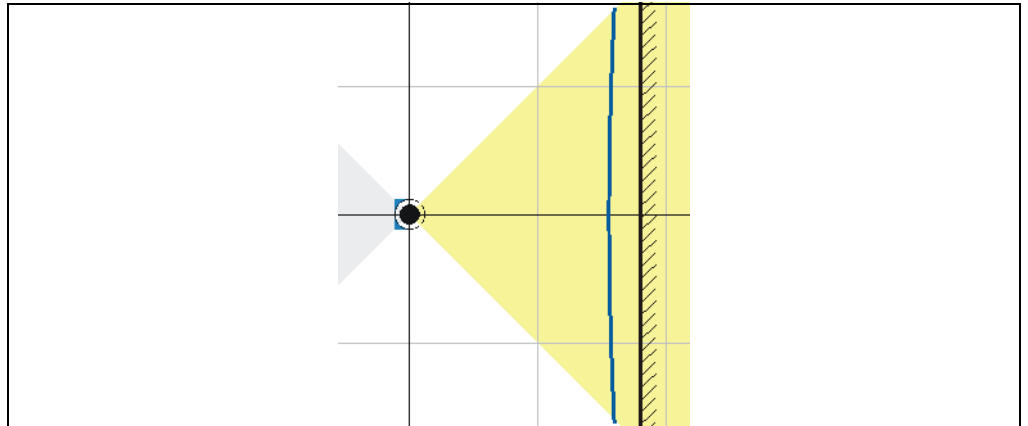

Fig. 18: Radial distance of an evaluation field to the scanned contour

#### How to teach-in an evaluation field:

1. In the selection field on the top left in the field editor choose the TEACHIN FIELD CONTOUR method.  
The TEACHIN FIELD CONTOUR dialog box is opened.
2. Enter the values for the FIRST ANGLE, LAST ANGLE and DISTANCE.
3. Click the START button.  
The contour will be scanned.
4. Then, click the STOP button.  
The evaluation field with its end points will be displayed.

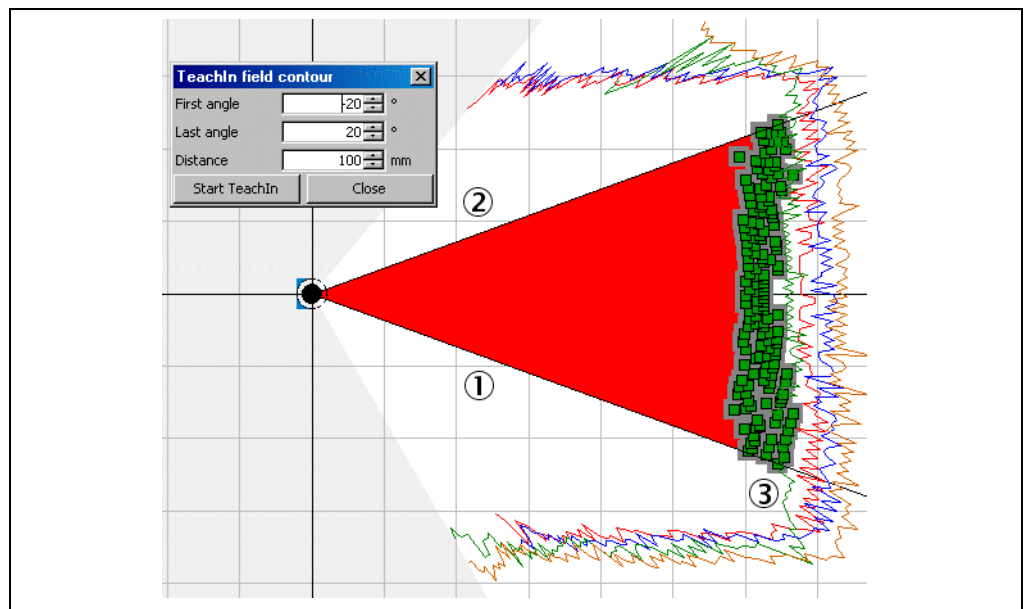

Fig. 19: Taught-in evaluation field with first angle (1), last angle (2) and distance (3)

#### Editing taught-in evaluation field

You can edit a taught-in evaluation field by moving or deleting the individual points for the field until the field has the required shape and size (see [section "How to move end points:" on page 14](#) and [section "How to delete end points:" on page 15](#)).

### Defining start points for a taught-in evaluation field

You can teach-in start points for an evaluation field.

**Important** If you do not want to teach-in any start points, then click EXIT. The evaluation field then reaches right up to the LD-MRS.

A start point must be set for each end point. For this reason the same values for the first and last angle are pre-defined as for teaching-in the end points.

By defining a larger distance (2) to the scanned contour (1) for the start points than on teaching-in the end points, you can fix the depth of the evaluation field.

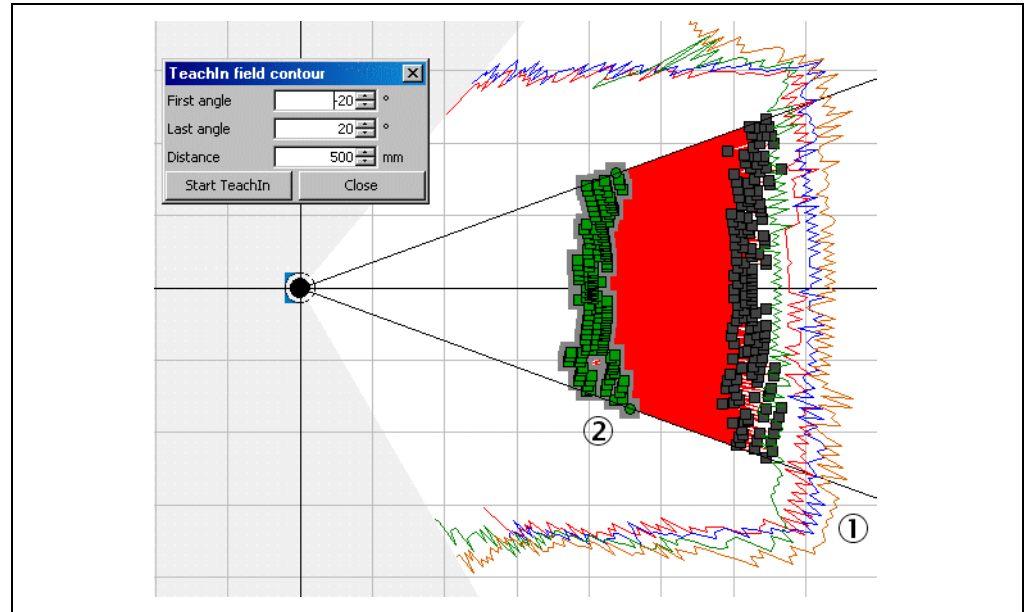

Fig. 20: Distance to the start points for a taught-in evaluation field

#### How to teach-in the start points of an evaluation field:

1. In the selection field on the top right in the field editor choose the TEACHIN FIELD CONTOUR option.  
The TEACHIN FIELD CONTOUR dialog box is opened.
1. Enter the value for the DISTANCE.  
The distance must be larger than when teaching-in the end points.
2. Click the START button.
3. Then, click the STOP button.  
The evaluation field with its start points will be displayed.

### 1.3.10 Defining reference contour

You can either teach-in or set manually an evaluation field for a reference contour. In both cases an evaluation field is placed around the scanned contour of an object.

The actual function is activated by the strategy for the evaluation case. Evaluation case and evaluation field must therefore match (see [section 1.4.4 "Evaluation strategy" on page 24](#)).

For the evaluation of the field, the contour of an object (e.g. a house wall) must always be present inside the field, i.e. an object must always be present (the scanned contour is used as a reference).

#### Teaching-in reference contour

**Important** A reference contour can only be taught-in if you have selected the SEGMENTED option in the basic parameters for the field.

**Recommendation** Show the scan line for the LD-MRS in the field editor. You can then see the scanned contour (1) and use it to orientate yourself.

You can define the first angle (2) and the last angle (3) used during teach-in and therefore pre-define the size of the field. The field you are creating is displayed in yellow.

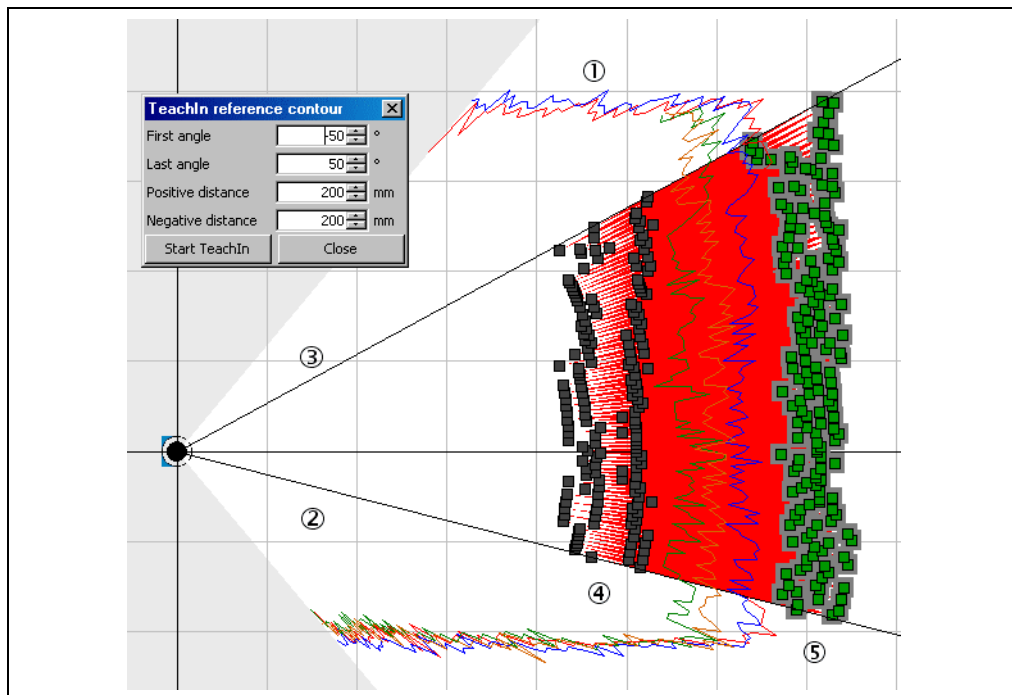

Fig. 21: Taught-in reference contour

For the evaluation field you must define the positive (4) and the negative (5) distance in relation to the scanned contour (1). The distance should be at least 100 mm (3.94 in), otherwise the evaluation field will be continuously infringed. The positive distance defines the start points, the negative distance the end points.

**How to teach-in an evaluation field for the contour as reference function:**

1. In the selection field on the top right in the field editor choose the TEACHIN REFERENCE CONTOUR option.  
The TEACHIN REFERENCE CONTOUR dialog box is opened.
2. Enter the values for FIRST ANGLE and LAST ANGLE as well as for the POSITIVE DISTANCE and the NEGATIVE DISTANCE.
3. Click the START button.  
The contour will be scanned.
4. Then, click the STOP button.  
The evaluation field with its end points and start points is placed around the contour and displayed.

**Manually editing reference contour**

**Recommendation** Show the scan line for the LD-MRS in the field editor. You can then see the scanned contour and use it to orientate yourself.

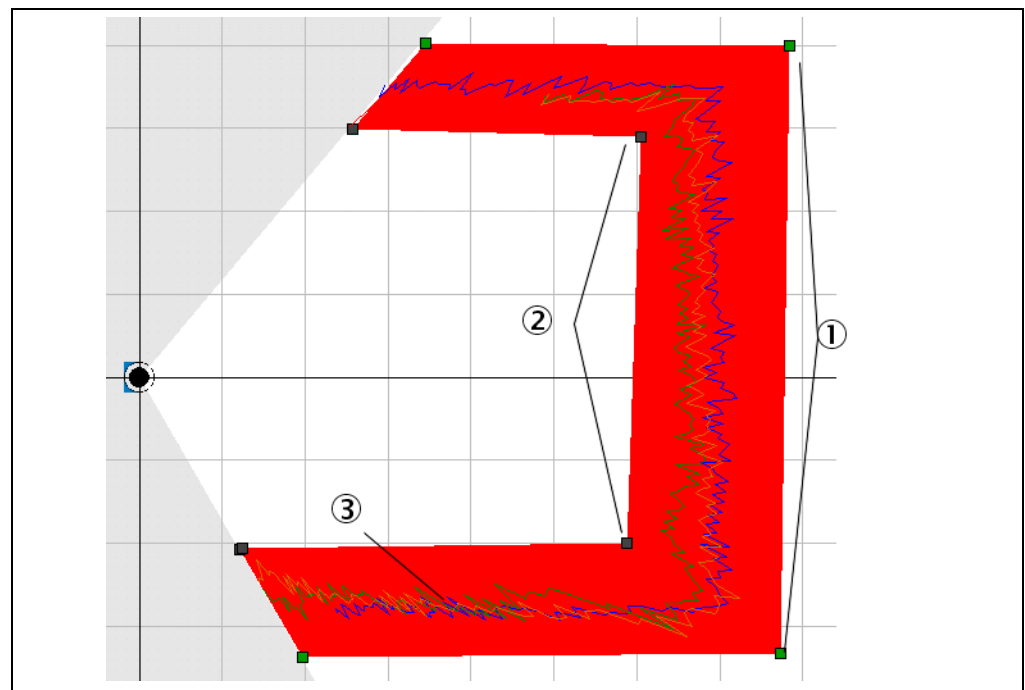

Fig. 22: Manually edited evaluation field for the evaluation of a contour

With end points (1) and start points (2) you can define the size of the evaluation field that you want to place around the contour of the object (3) at an adequate distance.



**How to manually edit an evaluation field for the reference contour:**

1. In the selection field on the top left in the field editor choose the MANUAL option.
  2. Set the end points of the evaluation field (see [section 1.3.6 "Setting end points for a segmented evaluation field" on page 13](#)).
  3. Set the start points of the evaluation field (see [section 1.3.7 "Setting start points for a segmented evaluation field" on page 15](#)).
- Ensure the positive and negative distance to the scanned contour for the field is sufficient (> 100 mm (3.94 in)).

### 1.4 Evaluation cases

With the aid of the field application integrated into the LD-MRS, up to 16 evaluation fields can be configured.

The existing evaluation cases are displayed in a table in the EVALUATION CASES OVERVIEW area. You can run the following functions using the buttons above the table:

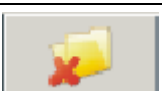
Symbol	Meaning	Comment
	Create evaluation case	You can create a new evaluation case using this button. The CREATE EVALUATION CASE dialog box is opened (see <a href="#">1.4.1 on page 23</a> ).
	Edit evaluation case	You can edit an existing evaluation case using this button. ➤ For this purpose mark one of the evaluation cases in the table and then click the button.
	Copy evaluation case	You can copy an existing evaluation case using this button. During this process, all parameters for the existing evaluation case are copied to the new evaluation case. ➤ For this purpose mark one of the evaluation cases in the table and then click the button.
	Delete evaluation case	You can delete an existing evaluation case using this button. ➤ For this purpose mark one of the evaluation cases in the table and then click the button.

Tab. 4: Buttons for managing the evaluation cases

#### How to configure the evaluation cases of the LD-MRS:



- In the PROJECT TREE, LD-MRS(NAME), PARAMETER, open the device page EVALUATION CASES. In the EVALUATION CASES OVERVIEW area you can create, copy, edit or delete evaluation cases.

#### 1.4.1 Name of the evaluation case

In SOPAS ET each evaluation case is given a name as well as its number.

- In the BASIC PARAMETERS area enter a name for the evaluation case in the NAME field.
- Use meaningful names that describe the evaluation case (such as forward movement, slow movement, day configuration, night configuration, etc.).

### 1.4.2 Inputs

If the evaluation case is not to be permanently active, then choose an input combination to activate the evaluation case. With the aid of the INPUT 1 and INPUT 2 fields you can configure whether the input must be active low or active high to activate the evaluation case.

You can also configure a combination of two input states to activate the evaluation case. As a result up to four combinations for activating different evaluations cases are possible.

Input 1	Input 2	Evaluation case
Active high	Active high	Evaluation case 1
Active high	Active low	Evaluation case 2
Active low	Active high	Evaluation case 3
Active low	Active low	Evaluation case 4

Tab. 5: Input combination examples

- Important**
- An input combination can also be defined for several evaluation cases, e.g. two evaluation cases will then be active simultaneously.
  - If you choose NOT RELEVANT for both inputs, the evaluation case is always active.
  - Choose whether and which input is to have the state active high or active low to activate the evaluation case.

### 1.4.3 Evaluation area (evaluation field)

For each evaluation case, you can define which evaluation field is to be used. You can only select fields for an evaluation case if you have first created at least one field (see [section 1.3 "Evaluation fields" on page 9](#)).

- Important**
- If you have selected the CONTOUR evaluation strategy, then only segmented fields are available.
- In the FIELD NAME selection field choose the required evaluation field.  
The number of the evaluation field is displayed in the NUMBER field.

### 1.4.4 Evaluation strategy

The evaluation strategy defines how the evaluation field is evaluated.

- Important**
- The different strategies will produce different results. For this reason the evaluation strategy must exactly match the type of evaluation field

#### Pixel evaluation

The LD-MRS evaluates the entire area of the evaluation field. If an object enters the field, this result is sent to the related output.

For the LD-MRS to detect an object, the object must be detected in one place for at least the duration of the RESPONSE TIME. The response time means that the presence of objects in the evaluation field will not immediately trigger the evaluation case. Objects must therefore be scanned several times if a response time is configured (for a scanning frequency of 25 Hz and a response time of 1,000 ms for example 25 times).

If pixel evaluation is configured, dazzle may result in it no longer being possible for the LD-MRS to monitor a field.

To prevent this situation arising, you can configure the TAMPER PROTECTION option. This feature switches the evaluation field if the LD-MRS is dazzled for longer than the EXPANDED RESPONSE TIME configured.



### Blanking

The LD-MRS evaluates the entire area of the evaluation field. Blanking can be used to ignore objects up to a certain size. An object is only detected if it is larger than the blanking size configured.

For the LD-MRS to detect an object, the object must be detected in one place for at least the duration of the RESPONSE TIME. The response time means that the presence of objects in the evaluation field will not immediately trigger the evaluation case. Objects must therefore be scanned several times if a response time is configured (for a scanning frequency of 25 Hz and a response time of 1,000 ms for example 25 times).

With the DISTANCE-DEPENDENT option, overlapping objects within a certain distance are regarded as one object.

The value in the OBJECT SEPARATION field defines the depth within which the two objects are combined.

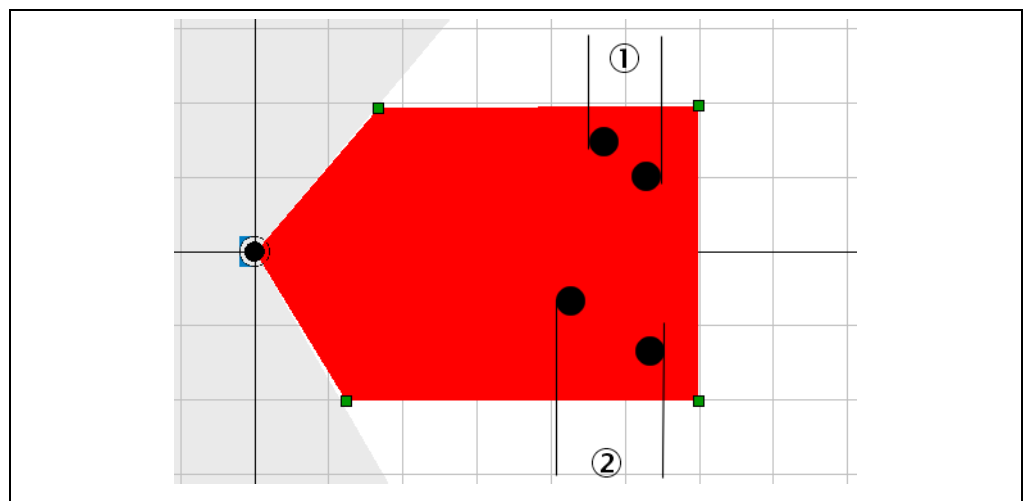

Fig. 23: Distance-dependent evaluation of two objects

In [Fig. 23](#) the objects in example (1) are so close together (distance  $\leq$  value in the OBJECT SEPARATION field) that they are considered as one object. As a result the objects are not blanked and the evaluation field is considered infringed.

In example (2) the objects are far enough apart (distance  $>$  value in the OBJECT SEPARATION field) that they are considered as two separate objects. As a result the objects are blanked and the evaluation field is considered to not be infringed.

If blanking is configured, small objects in the near range of the LD-MRS can cause large shadows. To prevent this situation arising, you can configure the TAMPER PROTECTION option. This feature switches the evaluation field if ...

- an object that is smaller than or equal to the blanked object size is in front of the laser output aperture on the LD-MRS for the configured EXPANDED RESPONSE TIME.
- the LD-MRS is dazzled for longer than the EXPANDED RESPONSE TIME configured.

### Contour monitoring with blanking

The LD-MRS evaluates the presence of a contour that must always be in the evaluation field (see [section 1.3.10 "Defining reference contour" on page 21](#)). As a result the LD-MRS can detect, e.g., that a door is opening or that the position of the LD-MRS is being changed. Also the crawling beneath a vertical evaluation field or the deflection of the laser beam by a mirror can be detected.

Blanking can be used to ignore that part of the contour is missing up to a certain size.

For the LD-MRS to detect a contour infringement, the infringement must be detected in one place for at least the duration of the RESPONSE TIME. The response time means that contour infringements will not immediately trigger the evaluation case. Contour infringements must therefore be scanned several times if a response time is configured (for a scanning frequency of 25 Hz and a response time of 1,000 ms for example 25 times).

#### 1.4.5 Evaluation result

The used evaluation field and the evaluation strategy for the evaluation case produce an evaluation result as soon as the field is infringed or the contour is interrupted.

- Choose the EXTERNAL OUTPUT on which the result of the evaluation case is to act.
- With the aid of the RESULT INVERTED option, choose whether the result of the evaluation case is to be inverted.

### 1.5 External inputs and outputs

#### 1.5.1 CAN modules

To implement switching output and inputs, one or two CAN modules are connected to the LD-MRS.

You can define whether the CAN module configuration is active and the device ID for the LD-MRS.

You can define how many modules are active. You can also define which ID the module has on the CAN bus.

For information on the connection of the module to the LD-MRS, the connection layout for the inputs and outputs as well as the module's configured ID, see the operating instructions for the LD-MRS and the operating instructions for the CAN module.

**Important** The LD-MRS and all modules must have different IDs between 0 and 127.

#### How to configure the CAN modules:



1. In the PROJECT TREE, LD-MRS (NAME), PARAMETER, EXTERNAL I/O , open the device page CAN MODULES
2. Select the option ACTIVE.
3. Activate the modules connected and assign the IDs to the modules.

#### 1.5.2 External digital outputs

On the LD-MRS there are ten external outputs. These outputs are implemented using one or two CAN modules and connected via their ports. For information on the connection of the module to the LD-MRS and the connection layout for the outputs, see the operating instructions for the CAN module.

For the outputs you can select whether they are to switch active high or active low.

If you have activated more than one CAN module, choose the module to which the external output is to be connected.

Then choose the port on the CAN module to which the output is to be connected.

**Important** Only if you have activated at least one CAN module (see [section 1.5.1 "CAN modules" on page 26](#)), can you configure the outputs.



#### How to configure the external digital outputs:

- In the PROJECT TREE, LD-MRS (NAME), PARAMETER, EXTERNAL I/O, open the device page DIGITAL OUTPUTS.

In the EXTERNAL OUTPUT 1...10 areas you can undertake the necessary configuration steps for the outputs.

#### 1.5.3 Digital outputs of the application

If several monitoring cases act on an output, you must define how the results of the monitoring cases are linked. The related results can be linked using a logical AND or a logical OR operator.

**Explanation** The LOGIC selection field is only active if you have configured at least two evaluation cases that act on the output (see [section 1.4.5 "Evaluation result" on page 26](#)).

By default the related output is reset immediately.

But you can configure a delay (e.g. to activate a horn or to send the signal to a PLC).

- In the RESET field select the option TIME. Configure in the DELAY field a time in ms for which the output remains in this active output state. Adjust the retention time to the input electronics on the downstream system.

#### How to configure the function of the outputs:



- In the PROJECT TREE, LD-MRS (NAME), PARAMETER, EXTERNAL I/O, open the device page EXTERNAL DIGITAL OUTPUTS.

In the EXTERNAL OUTPUT 1...10 APPLICATION areas you can undertake the necessary configuration steps for the outputs.

#### 1.5.4 External inputs

Two external inputs are available on the LD-MRS. These outputs are implemented using one or two CAN modules and connected via their ports. For information on the connection of the module to the LD-MRS and the connection layout of the outputs, see the operating instructions for the CAN module.

If you have activated more than one CAN module, choose the module to which the external input is to be connected.

Then choose the port on the CAN module to which the input is to be connected.

**Important** Only if you have activated at least one CAN module (see [section 1.5.1 "CAN modules" on page 26](#)), can you configure the inputs.

#### How to configure the external inputs:



- In the PROJECT TREE, LD-MRS (NAME), PARAMETER, EXTERNAL I/O, open the device page EXTERNAL INPUTS.

In the EXTERNAL INPUT 1...2 areas you can undertake the necessary configuration steps for the inputs.

## 2 Monitor

### 2.1 Field evaluation monitor

In the field evaluation monitor you can use the same tools to configure the view as in the field editor (see [section 1.3.3 "Adapting the field editor view" on page 11](#) as well as [section 1.3.4 "Showing or hiding layers and echos" on page 12](#)).

Using the field evaluation monitor, you can analyze whether and how evaluation fields are infringed and how the outputs on the LD-MRS behave.

**Important** The indication of events, such as field or contour infringements, appears on the monitor with a slight delay.

- In the top right selection field, choose whether you want to monitor the outputs or the evaluation cases.

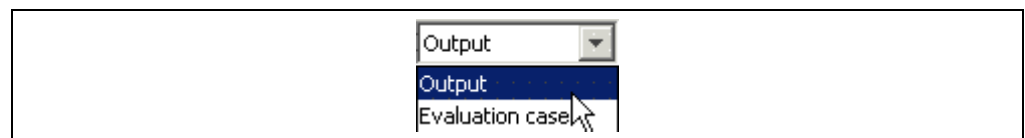

Fig. 24: Selection of the indication on the monitor

#### Display of the evaluation cases

- In the EVALUATION CASE area, choose the evaluation case to be monitored.
  - Under the name of the evaluation case, the configured strategy, the field allocated and the status of the field are displayed in different colors.
    - Green: The evaluation field for the evaluation case has not been infringed.
    - Yellow: The evaluation field for the evaluation case has been infringed.
    - Grey: The evaluation case is invalid, for instance because the evaluation field allocated has been deleted.

The evaluation field allocated to the evaluation case is displayed in the actual diagnostics window.

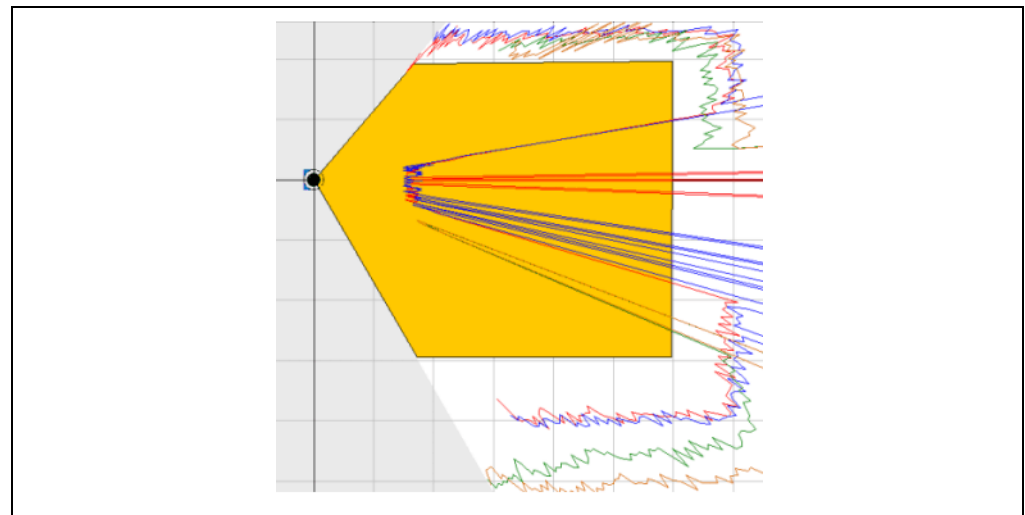

Fig. 25: Indication of an infringed evaluation field on the monitor

In the OUTPUTS area the states and the number of switching actions since switching on are displayed for outputs 1 to 10.

Display of the outputs

- In the OUTPUT area, choose the switching output to be monitored.  
Under the name of the output, the name and number of the evaluation cases on which the output acts are displayed.  
The evaluation fields allocated to the output are displayed in different colors in the actual diagnostics window.
  - Green: The evaluation field has not been infringed.
  - Yellow: The evaluation field has been infringed.
- In the OUTPUTS area the states and the number of switching actions since switching on are displayed for outputs 1 to 10.

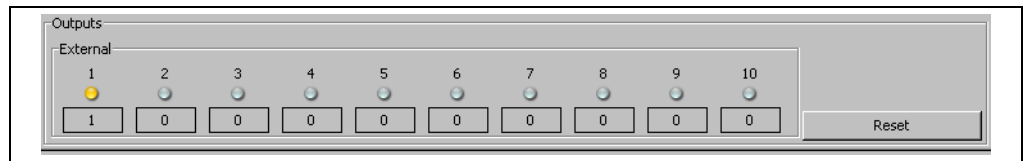

Fig. 26: Display of the outputs on the monitor

- Click the RESET button.  
The number of switching actions is reset to 0.

Display of the inputs

In the INPUTS area the states for inputs 1 and 2 are displayed.



Fig. 27: Display of the inputs on the monitor

Showing or hiding layers and echos

With the aid of the matrix at the bottom right of the monitor, you can show or hide the individual layers and the echos that are measured in the individual layers.

**Important** Showing or hiding layers only affects the display of data on the monitor.

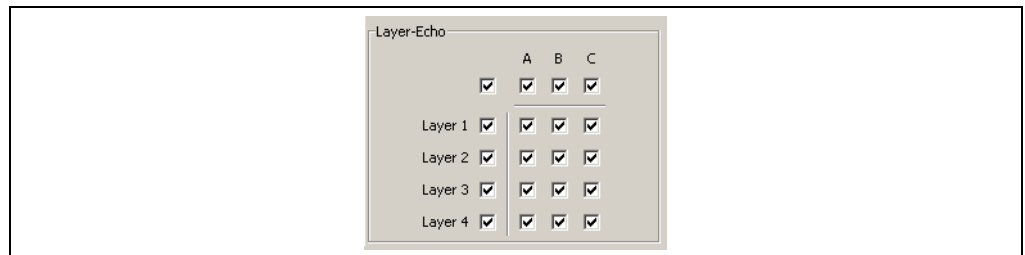

Fig. 28: Showing or hiding layers and echos on the monitor

How to open the field evaluation monitor:



- In the PROJECT TREE, LD-MRS (NAME), MONITOR, open the device page FIELD EVALUATION MONITOR.  
In the FIELD EVALUATION MONITOR area you can see the configured fields for the LD-MRS in operation.

## 3 Glossary

**Note** For other terms, see also the online help for the SOPAS ET configuration software.

### Download

Transmission of the parameter set that has been modified offline in the SOPAS ET configuration software from the PC to the LD-MRS. SOPAS ET transmits either always a complete copy to the memory (RAM) of the LD-MRS (menu COMMUNICATION, DOWNLOAD ALL PARAMETERS TO DEVICE) or only the parameter that has just been edited with the aid of the context menu opened using the right mouse button (menu COMMUNICATION, DOWNLOAD MODIFIED PARAMETERS TO DEVICE). With menu LD-MRS (NAME), PARAMETER, SAVE PERMANENT, the parameter set is saved permanently in the EEPROM of the LD-MRS.

### Line scanner

Scanner that very rapidly deflects its focused laser beam with the aid of a polygon mirror wheel with mirrors parallel to the axis. In this way the scanner generates a dot of light in the measuring plane that repeatedly runs along a straight line and appears to be a "stationary" scan line due to the relative slow response of the human eye.

### Parameter set

Data set using which the functions implemented in the LD-MRS are initialized and activated. Is transmitted from the LD-MRS to SOPAS ET and in the reverse direction using UPLOAD or DOWNLOAD respectively.

### SOPAS ET

Configuration software, can be used with Windows 2000/XP/Vista. Is used for the offline configuration (adaptation to the read situation on-site) and the online operation of the LD-MRS in the dialog box.

### SOPAS ET setup help

Online help that supports the usage of the SOPAS ET configuration software. The functions of the parameters for the LD-MRS are explained in the Help and the related value ranges given. Can be used with an HTML browser, e.g. Internet Explorer and can be opened from SOPAS ET setup.

### Upload

Transmission of the parameter set from the LD-MRS to the PC into the SOPAS ET configuration software. The values for the parameters are displayed on the file cards of the configuration software. Prerequisite for the modification of the current parameter set.

## 4 Index

<b>A</b>	
Activation of an evaluation case .....	24
Angular resolution .....	5
<b>B</b>	
Blanking .....	25
<b>C</b>	
Configuration .....	4
Contour as reference .....	21
Contour monitoring with blanking .....	25
<b>D</b>	
Dazzle .....	24
<b>E</b>	
Evaluation cases .....	23
Evaluation field	
Rectangular .....	9
Segmented .....	9
Teach-in .....	18
Evaluation fields .....	9
Evaluation strategy .....	24
Expanded response time .....	24, 25
External switching outputs .....	26
<b>F</b>	
Field editor view .....	11
Filters .....	7
<b>I</b>	
Inputs .....	24
<b>M</b>	
Monitor .....	28
<b>O</b>	
Outputs .....	26, 27
<b>P</b>	
Password .....	4
Pixel evaluation .....	24

**R**

Rectangular field ..... 16  
Reference ..... 21  
Resetting configuration ..... 4, 5  
Response time with blanking ..... 25  
Response time with contour monitoring ..... 26  
Response time with pixel evaluation ..... 24

**S**

Save as PDF ..... 4  
Save parameters ..... 4  
Scanning frequency ..... 5  
Setting end points ..... 13  
Setting start points ..... 15  
Shading ..... 24  
Software version ..... 2  
Starting angle ..... 6  
Stopping angle ..... 6  
Switching outputs ..... 27  
Switching outputs external, outputs external ..... 26





**Australia**

Phone +61 3 9497 4100  
1800 33 48 02 – tollfree  
E-Mail sales@sick.com.au

**Belgium/Luxembourg**

Phone +32 (0)2 466 55 66  
E-Mail info@sick.be

**Brasil**

Phone +55 11 3215-4900  
E-Mail sac@sick.com.br

**Ceská Republika**

Phone +420 2 57 91 18 50  
E-Mail sick@sick.cz

**China**

Phone +852-2763 6966  
E-Mail ghk@sick.com.hk

**Danmark**

Phone +45 45 82 64 00  
E-Mail sick@sick.dk

**Deutschland**

Phone +49 211 5301-301  
E-Mail kundenservice@sick.de

**España**

Phone +34 93 480 31 00  
E-Mail info@sick.es

**France**

Phone +33 1 64 62 35 00  
E-Mail info@sick.fr

**Great Britain**

Phone +44 (0)1727 831121  
E-Mail info@sick.co.uk

**India**

Phone +91-22-4033 8333  
E-Mail info@sick-india.com

**Israel**

Phone +972-4-999-0590  
E-Mail info@sick-sensors.com

**Italia**

Phone +39 02 27 43 41  
E-Mail info@sick.it

**Japan**

Phone +81 (0)3 3358 1341  
E-Mail support@sick.jp

**Nederlands**

Phone +31 (0)30 229 25 44  
E-Mail info@sick.nl

**Norge**

Phone +47 67 81 50 00  
E-Mail austefjord@sick.no

**Österreich**

Phone +43 (0)22 36 62 28 8-0  
E-Mail office@sick.at

**Polska**

Phone +48 22 837 40 50  
E-Mail info@sick.pl

**Republic of Korea**

Phone +82-2 786 6321/4  
E-Mail info@sickkorea.net

**Republika Slovenija**

Phone +386 (0)1-47 69 990  
E-Mail office@sick.si

**România**

Phone +40 356 171 120  
E-Mail office@sick.ro

**Russia**

Phone +7 495 775 05 34  
E-Mail info@sick-automation.ru

**Schweiz**

Phone +41 41 619 29 39  
E-Mail contact@sick.ch

**Singapore**

Phone +65 6744 3732  
E-Mail admin@sicksgp.com.sg

**South Africa**

Phone +27 11 472 3737  
E-Mail info@sickautomation.co.za

**Suomi**

Phone +358-9-25 15 800  
E-Mail sick@sick.fi

**Sverige**

Phone +46 10 110 10 00  
E-Mail info@sick.se

**Taiwan**

Phone +886 2 2375-6288  
E-Mail sales@sick.com.tw

**Türkiye**

Phone +90 216 528 50 00  
E-Mail info@sick.com.tr

**United Arab Emirates**

Phone +971 4 8865 878  
E-Mail info@sick.ae

**USA/Canada/México**

Phone +1(952) 941-6780  
1 800-325-7425 – tollfree  
E-Mail info@sickusa.com

More representatives and agencies  
at [www.sick.com](http://www.sick.com)