

Type 8791

Positioner SideCONTROL BASIC

Electropneumatic positioner

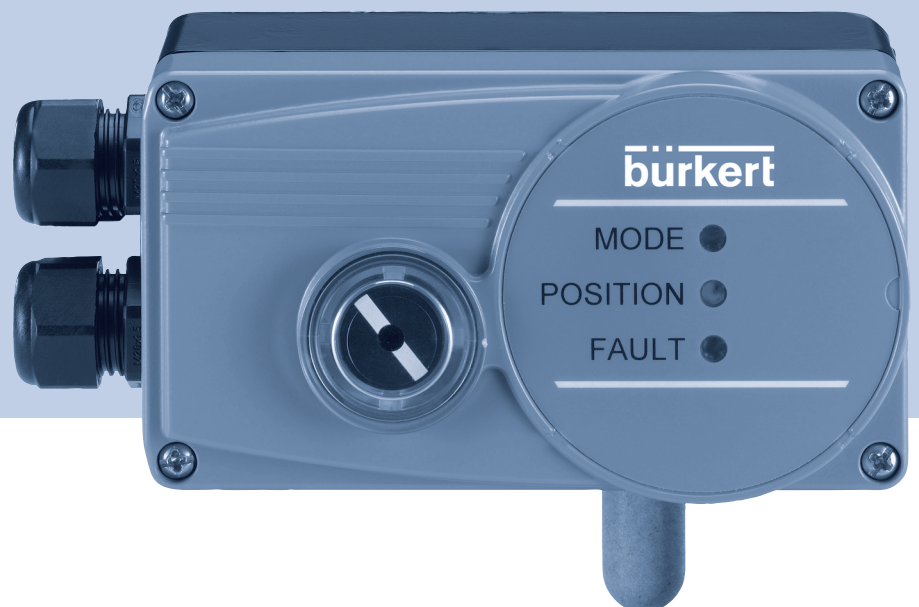

Operating Instructions

We reserve the right to make technical changes without notice.
Technische Änderungen vorbehalten.
Sous réserve de modifications techniques.

© Bürkert Werke GmbH & Co. KG, 2009 – 2019

Operating Instructions 1902/10_EU-EN_00805664 / Original DE

Electropneumatic positioner Type 8791

CONTENTS

1	OPERATING INSTRUCTIONS	8
1.1	Symbols.....	8
1.2	Definition of term / abbreviation.....	8
2	AUTHORIZED USE	9
3	BASIC SAFETY INSTRUCTIONS	10
4	GENERAL INFORMATION.....	11
4.1	Contact addresses.....	11
4.2	Warranty	11
4.3	Information on the Internet.....	11
5	DESCRIPTION OF SYSTEM.....	12
5.1	General description.....	12
5.1.1	Features	12
5.1.2	Combination with valve types and mounting versions.....	13
5.1.3	Optionally external position feedback with inductive proximity switch.....	13
5.1.4	Overview of the mounting options.....	14
6	STRUCTURE.....	15
6.1	Representation.....	15
7	FUNCTION.....	16
7.1	Function diagram	16
7.2	Function of the position control	17
7.3	Schematic representation of the position control.....	18
7.4	Properties of the positioner software.....	19
7.4.1	Functions I	19
7.4.2	Functions II	20
7.5	Interfaces of the positioner	21
8	TECHNICAL DATA	22
8.1	Conformity.....	22

8.2	Standards	22
8.3	Operating conditions	22
8.4	Mechanical data.....	22
8.5	Electrical data	23
8.5.1	Electrical data 24 V DC.....	23
8.5.2	Electrical data with AS-Interface bus control (optional)	23
8.6	Pneumatic data	24
8.7	Safety end positions after failure of the electrical or pneumatic auxiliary power.....	25
8.8	Factory settings of the positioner	26
8.8.1	Functions can be activated via DIP switches	26
8.8.2	Functions can be activated via communications software.....	26
9	OPERATING.....	27
9.1	Safety instructions	27
9.2	Operating status.....	27
9.3	Control and display elements of the positioner.....	27
9.3.1	Configuration of the keys.....	28
9.3.2	Function of the DIP switches.....	29
9.3.3	Display of the LEDs	30
9.4	Error messages.....	31
9.4.1	Error messages in MANUAL and AUTOMATIC operating status	31
9.4.2	Error messages while the X.TUNE function is running	31
10	FUNCTIONS.....	32
10.1	Basic functions.....	32
10.1.1	DIR.CMD - Effective sense of direction of the positioner set-point value.....	33
10.1.2	CUTOFF - Sealing function for the positioner.....	34
10.1.3	CHARACT - Transfer characteristic between input signal (position set-point value) and stroke....	35
10.1.4	INPUT - Enter the input signal.....	37
10.1.5	RESET - Reset to factory settings.....	38
10.1.6	X.TUNE - Automatic adjustment of the positioner to the relevant operating conditions.....	38

10.2	Additional functions	39
10.2.1	DIR.ACTUATOR - Effective direction of the actuator.....	39
10.2.2	SPLITRANGE - Signal split range	40
10.2.3	X.LIMIT - Limiting the mechanical stroke range.....	41
10.2.4	X.TIME - Limiting the control speed	42
10.2.5	X.CONTROL - Parameterization of the positioner.....	43
10.2.6	SAFE POSITION - Definition of the safe position.....	43
10.2.7	SIGNAL ERROR - Configuration of signal level fault detection	44
10.2.8	BINARY INPUT - Activation of the binary input.....	44
10.2.9	OUTPUT (optional) - Configuration of the analog output.....	45
11	ATTACHMENT AND ASSEMBLY	46
11.1	Safety instructions	46
11.2	Attachment to a proportional valve with NAMUR linear actuators.....	47
11.2.1	Attachment kit (IEC 534-6) for linear actuators (order no. 787215).....	47
11.2.2	Installation.....	48
11.2.3	Attaching mounting bracket	50
11.2.4	Aligning lever mechanism.....	51
11.3	Attachment to a proportional valve with rotary actuator	52
11.3.1	Attachment kit (VDI/VDE 3845) on rotary actuator (order no. 787338).....	52
11.3.2	Installation.....	52
11.4	Remote operation with external position sensor.....	55
11.4.1	Mounting accessories.....	55
11.4.2	Connection and start-up of the Remote-Sensor Type 8798	56
12	FLUID CONNECTION	57
12.1	Safety instructions	57
13	ELECTRICAL CONNECTION.....	59
13.1	Safety instructions	59

13.2	Electrical connection with circular plug-in connector	59
13.2.1	Designation of the circular plug-in connector	59
13.2.2	Pin assignment for input signals from the control centre (e.g. PLC) - M12, 8-pole plug	60
13.2.3	Pin assignment for output signals to the control centre (e.g. PLC) - M12, 8-pole plug (required for analogue output option only)	60
13.2.4	Pin assignment for operating voltage - M12, 8-pole circular plug-in connector	60
13.3	Electrical connection with cable gland	61
13.3.1	Designation of the screw-type terminals	61
13.3.2	Connection of the screw-type terminals	61
13.3.3	Terminal assignment for input signals from the control centre (e.g. PLC)	61
13.3.4	Terminal assignment for output signals to the control centre (e.g. PLC) (required for analogue output option only)	62
13.3.5	Terminal assignment for operating voltage	62
13.3.6	Terminal assignment for external position sensor (for remote model only)	62
14	START-UP	63
14.1	Safety instructions	63
14.2	Specifying the standard settings	63
14.2.1	Running the automatic adjustment X.TUNE :	63
15	AS-INTERFACE	65
15.1	AS-Interface connection	65
15.4	Communication sequence for the version S-7.A.5 profile	66
15.5	LED status display (bus)	67
15.6	Electrical connection AS-Interface	68
15.6.1	Safety instructions	68
15.6.2	Connection with M12 circular plug-in connector, 4-pole, male	68
16	SERVICE	69
17	ACCESSORIES	69
17.1	Communications software	69
17.1.1	USB interface	69
17.1.2	Download	69
18	PACKAGING AND TRANSPORT	70

19	STORAGE	70
20	DISPOSAL	70

1 OPERATING INSTRUCTIONS

These operating instructions describe the entire life cycle of the device. Keep these instructions in a location which is easily accessible to every user and make these instructions available to every new owner of the device.

Important safety information.

Read the operating instruction carefully and thoroughly. Study in particular the chapters entitled “[Basic Safety Instructions](#)” and “[Authorized use](#)”.

- ▶ The operating instructions must be read and understood.

1.1 Symbols



DANGER!

Warns of an immediate danger.

- ▶ Failure to observe the warning may result in a fatal or serious injury.



WARNING!

Warns of a potentially dangerous situation.

- ▶ Failure to observe the warning may result in serious injuries or death.



CAUTION!

Warns of a possible danger.

- ▶ Failure to observe this warning may result in a medium or minor injury.

NOTE!

Warns of damage to property.

- ▶ Failure to observe the warning may result in damage to the device or the equipment.



Indicates important additional information, tips and recommendations.



Refers to information in these operating instructions or in other documentation.

- ▶ Designates an instruction to prevent risks.

→ Designates a procedure that must be carried out.

1.2 Definition of term / abbreviation

The term “device” used in these instructions always stands for the positioner type 8791.

In these instructions, the abbreviation “Ex” always refers to “potentially explosive”.

2 AUTHORIZED USE

Incorrect use of the positioner Type 8791 can be dangerous to people, nearby equipment and the environment.

The device is designed for the open-loop control and closed-loop control of media.

- ▶ Do not expose the device to direct sunlight.
- ▶ Pulsating direct voltage (rectified alternating voltage without smoothing) must not be used as supply voltage.
- ▶ In the potentially explosion-risk area the positioner type 8791 may be used only according to the specification on the separate Ex rating plate. For use observe the additional information enclosed with the device together with safety instructions for the explosion-risk area.
- ▶ Devices without a separate Ex rating plate may not be used in a potentially explosive area.
- ▶ During use observe the permitted data, the operating conditions and conditions of use specified in the contract documents and operating instructions, as described in chapter [“8 Technical data”](#) in this manual and in the valve manual for the respective pneumatically actuated valve.
- ▶ The device may be used only in conjunction with third-party devices and components recommended and authorised by Bürkert.
- ▶ In view of the wide range of possible application cases, check whether the positioner is suitable for the specific application case.
- ▶ Correct transportation, correct storage and installation and careful use and maintenance are essential for reliable and faultless operation.
- ▶ Use the positioner Type 8791 only as intended.

3 BASIC SAFETY INSTRUCTIONS

These safety instructions do not make allowance for any

- contingencies and events which may arise during the installation, operation and maintenance of the devices.
- local safety regulations – the operator is responsible for observing these regulations, also with reference to the installation personnel.



Risk of injury from high pressure in the equipment/device.

- ▶ Before working on equipment or device, switch off the pressure and deaerate/drain lines.

Risk of electric shock.

- ▶ Before working on equipment or device, switch off the power supply and secure to prevent reactivation.
- ▶ Observe applicable accident prevention and safety regulations for electrical equipment.

General hazardous situations.

To prevent injury, ensure that:

- ▶ That the system cannot be activated unintentionally.
- ▶ Installation and repair work may be carried out by authorised technicians only and with the appropriate tools.
- ▶ After an interruption in the power supply or pneumatic supply, ensure that the process is restarted in a defined or controlled manner.
- ▶ The device may be operated only when in perfect condition and in consideration of the operating instructions.
- ▶ The general rules of technology apply to application planning and operation of the device.

To prevent damage to property on the device, ensure:

- ▶ Do not supply the supply pressure connection of the system with aggressive or flammable mediums.
- ▶ Do not supply the supply pressure connection with any liquids.
- ▶ Do not put any loads on the housing (e.g. by placing objects on it or standing on it).
- ▶ Do not make any external modifications to the device housings. Do not paint the housing parts or screws.

NOTE!

Electrostatic sensitive components / modules.

The device contains electronic components which react sensitively to electrostatic discharge (ESD). Contact with electrostatically charged persons or objects is hazardous to these components. In the worst case scenario, they will be destroyed immediately or will fail after start-up.

- ▶ Observe the requirements in accordance with EN 61340-5-1 to minimise or avoid the possibility of damage caused by sudden electrostatic discharge.
- ▶ Also ensure that you do not touch electronic components when the power supply voltage is present.

4 GENERAL INFORMATION

4.1 Contact addresses

Germany

Contact address:

Bürkert Fluid Control Systems
Sales Center
Christian-Bürkert-Str. 13-17
D-74653 Ingelfingen
Tel. + 49 (0) 7940 - 10 91 111
Fax + 49 (0) 7940 - 10 91 448
E-mail: info@buerkert.com

International

Contact addresses can be found on the final pages of these printed operating instructions.

And also on the internet at:

www.burkert.com

4.2 Warranty

The warranty is only valid if the positioner Type 8791 are used as intended in accordance with the specified application conditions.

4.3 Information on the Internet

The operating instructions and data sheets for Type 8791 can be found on the internet at:

www.burkert.com

5 DESCRIPTION OF SYSTEM

5.1 General description

The positioner Type 8791 is a digital, electropneumatic positioner for pneumatically actuated proportional valves. The device incorporates the main function groups

- Position sensor
- Electropneumatic control system
- Microprocessor electronics

The position sensor measures the current positions of the proportional valve.

The microprocessor electronics continuously compare the current position (actual value) with a set-point position value specified via the standard signal input and supplies the result to the positioner.

If there is a control difference, the electropneumatic control system corrects the actual position accordingly.

5.1.1 Features

- **Version**

Positioner:

The position of the actuator is regulated according to the position set-point value. The position set-point value is specified by an external standard signal or via field bus.

- **Position sensor**

- internal high resolution conductive potentiometer or
- external non-contact, non-wearing position sensor (remote).

- **Microprocessor-controlled electronics**

for signal processing, control and valve control.

- **Control module**

The unit is operated via 2 keys and 4 DIP switches.
3 LEDs indicate the status of the unit.

- **Control system**

The control system consists of 2 solenoid valves and 4 diaphragm reinforcers. In single-acting actuators the working connection 2 must be sealed with a threaded plug.

- **Feedback (optional)**

The feedback is implemented either via 2 proximity switches or via an 4 – 20 mA output.
The operator can change the proximity switches or limit positions via control lugs.

- **Pneumatic interfaces**

Internal thread G1/4"

- **Electrical interfaces**

Circular plug-in connector or cable gland

- **Communications interface**

For configuration and parameterization

- **Housing**

Plastic-coated aluminium housing with hinged cover and captive screws.

- **Mounting**

on linear actuator according to NAMUR recommendation (DIN IEC 534-6) or on rotary actuator according to VDI/VDE 3845.

- **Optional**

Remote version for DIN rail mounting or for mounting bracket

5.1.2 Combination with valve types and mounting versions

The positioner Types 8791 can be mounted on different proportional valves. For example on valves with linear (piston), membrane or rotary actuator. The actuators can be single-acting or double-acting.

- For single-acting actuators, only one chamber is aerated and deaerated during actuation. The generated pressure works against a spring. The piston moves until there is an equilibrium of forces between compressive force and spring force. To do this, one of the two air connections must be sealed with a threaded plug.
- For double-acting actuators the chambers on both sides of the piston are pressurised. In this case, one chamber is aerated when the other one is deaerated and vice versa. In this design, no spring is installed in the actuator.

Two basic device versions are offered for the positioner Type 8791; they differ in the attachment option and in the position sensor.

Device version NAMUR:

An internal position sensor is used which is designed as a rotary potentiometer. The positioner is attached directly to the actuator.

Device version Remote:

An external position sensor (linear or rotative) via a digital interface. The positioner is attached to a wall either with a DIN rail or with a mounting bracket (remote design).

5.1.3 Optionally external position feedback with inductive proximity switch

The positioner type 8791 can be fitted with an external position feedback (see data sheet / accessories).

The installation and the setting are described in the installation instructions which are enclosed with the external position feedback.

The installation instructions can also be found on the Internet.

www.burkert.com → Type 8791

5.1.4 Overview of the mounting options

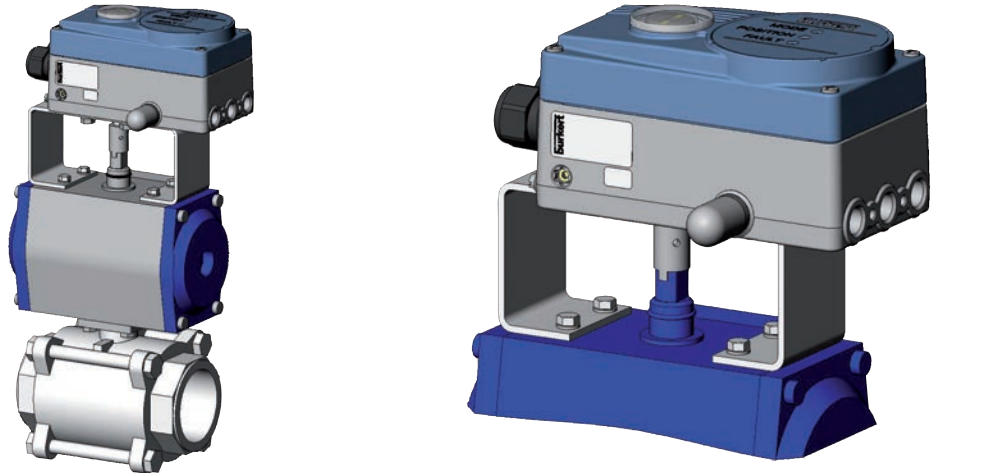
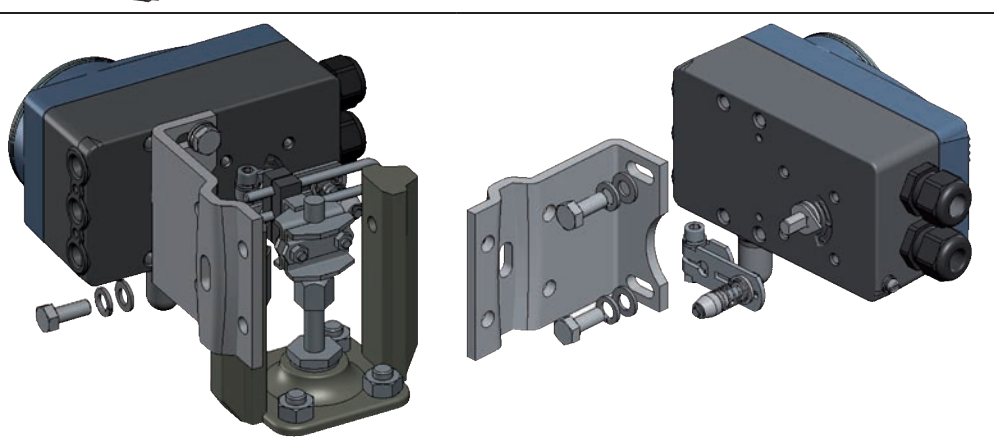
<p>Mounting NAMUR on rotary actuator</p>	
<p>Mounting NAMUR with mounting bracket on a linear actuator</p>	
<p>Remote mounting with mounting bracket</p>	
<p>Remote mounting with DIN rail</p>	

MAN 1000335622 EN Version: D Status: RL (released | freigegeben) printed: 28.02.2026

Table 1: Overview of the mounting options

6 STRUCTURE

The positioner Type 8791 consist of the micro-processor controlled electronics, the position sensor and the control system.

The appliance is designed using three-wire technology. The unit is operated via 2 keys and 4 DIP switches. 3 LEDs indicate the different statuses of the unit.

The pneumatic control system for single-acting and double-acting actuators consists of 2 solenoid valves.

6.1 Representation

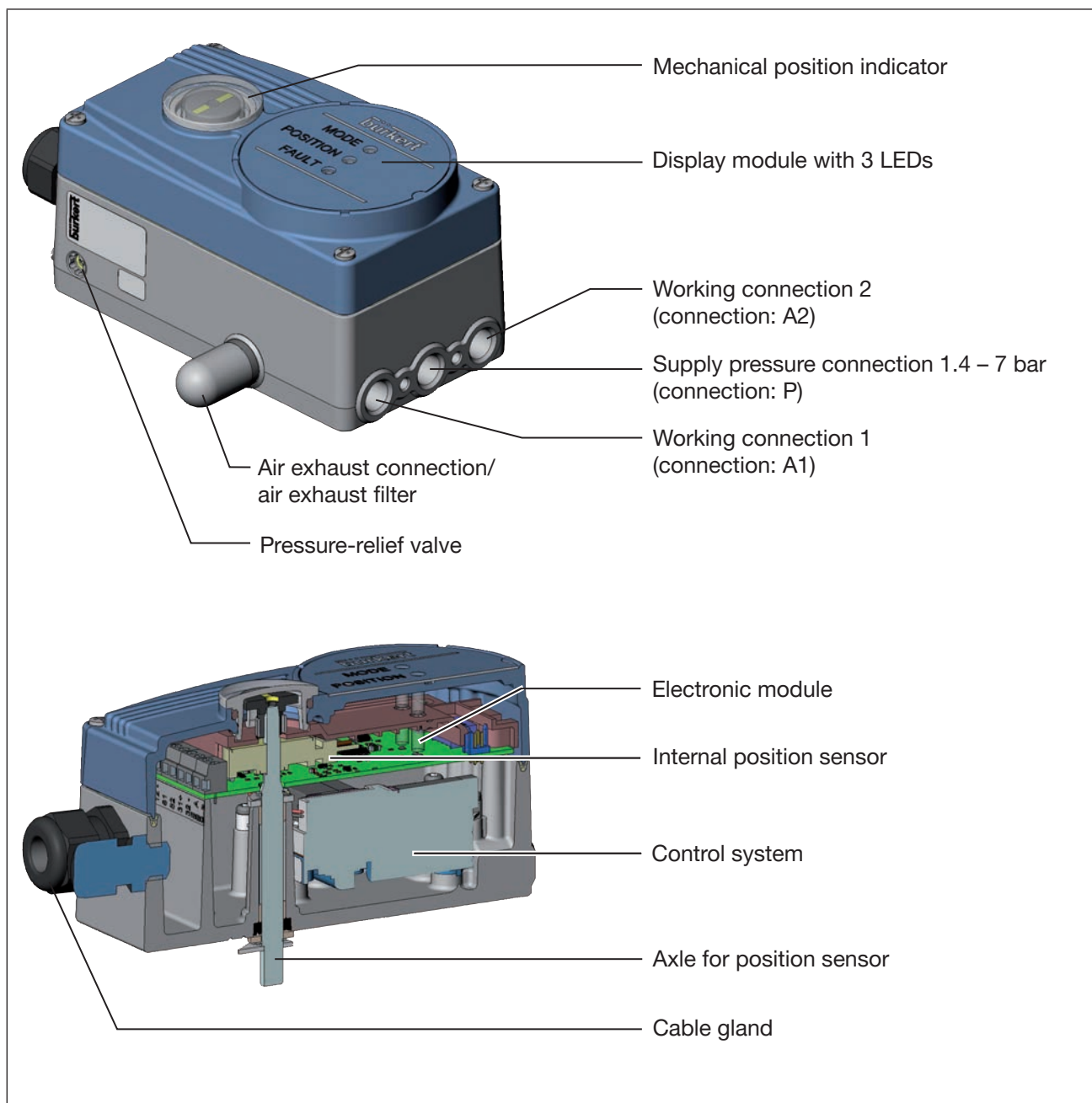

MAN 1000335622 EN Version: D Status: RL (released | freigegeben) printed: 28.02.2026

Figure 1: Structure, positioner type 8791

7 FUNCTION

7.1 Function diagram

Diagram illustrating single-acting actuator

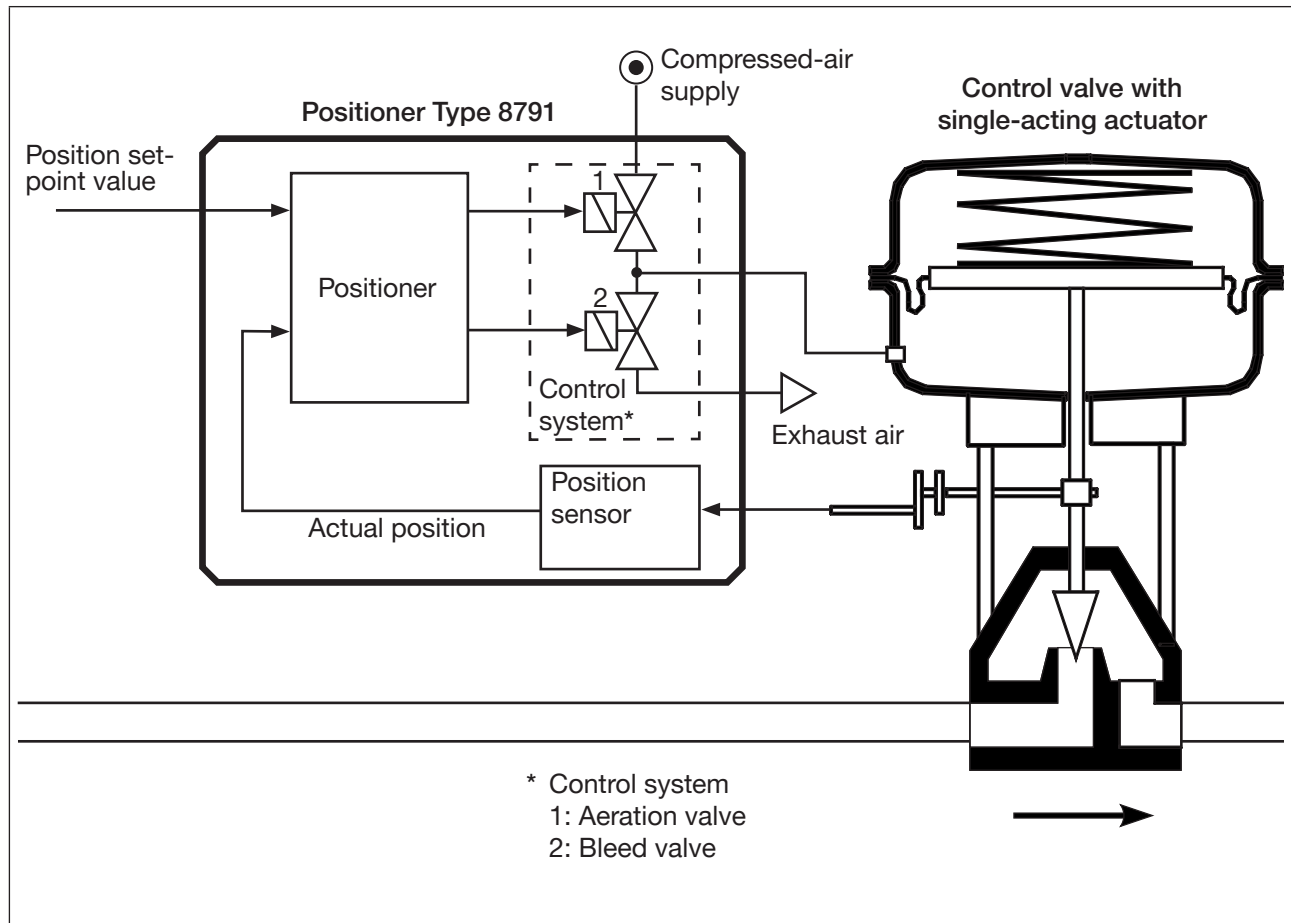

Figure 2: Function diagram, positioner type 8791



The remote design has the position sensor situated outside the positioner directly on the proportional valve and is connected to the latter by a cable.

7.2 Function of the position control

The position sensor records the current position (POS) of the pneumatic actuator. The positioner compares this actual position value with the set-point value (CMD) which is a standard signal. If there is a control difference (X_{d1}), the actuator is aerated and deaerated via the control system. In this way the position of the actuator is changed until control difference is 0. Z_1 represents a disturbance variable.

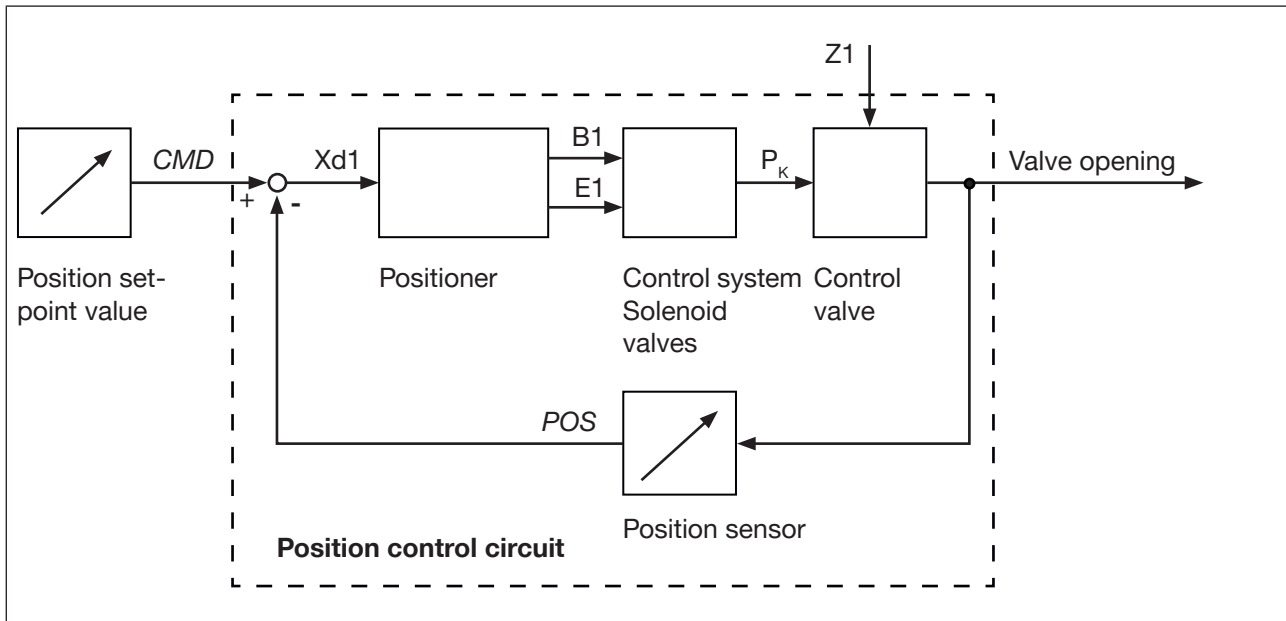

Figure 3: Signal flow plan of positioner

7.3 Schematic representation of the position control

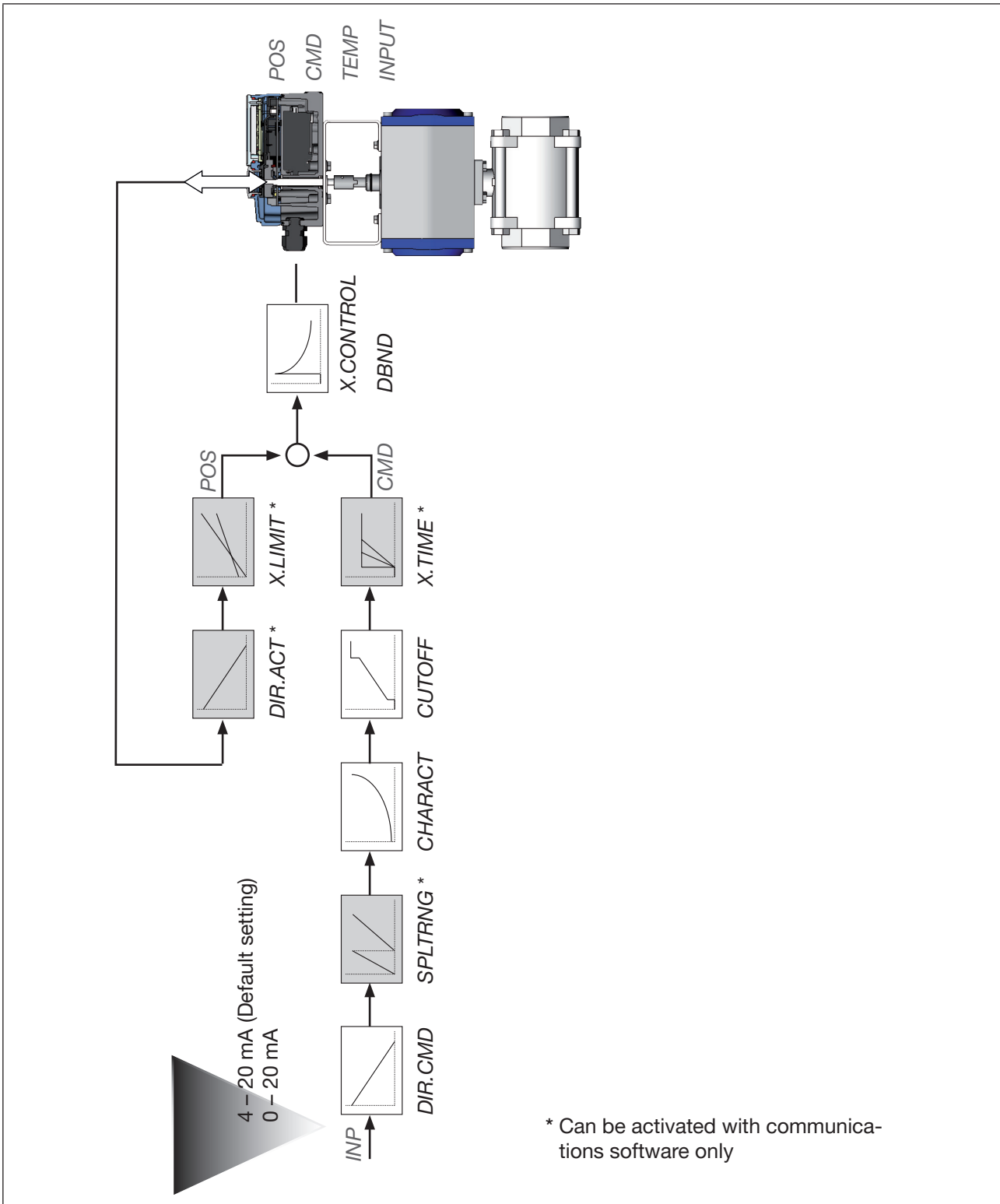

Figure 4: Schematic representation of position control

7.4 Properties of the positioner software

7.4.1 Functions I

- Activation via DIP switches
- Parameter setting via communications software

Additional function	Effect
Sealing function <i>CUTOFF</i>	Valve closes tight outside the control range. Specification of the value (as %) from which the actuator is completely deaerated (when 0%) or aerated (when 100%) (see chapter entitled “9.3.2 Function of the DIP switches”).
Correction line to adjust the operating characteristic <i>CHARACT</i>	The operating characteristic may be linearized (see chapter entitled “9.3.2 Function of the DIP switches”).
Effective sense of direction of the controller nominal value <i>DIR.CMD</i> ¹⁾	Reversal of the effective sense of direction of the set-point value (see chapter entitled “9.3.2 Function of the DIP switches”).

Table 2: Functions I



¹⁾ *DIR.CMD* can be accessed in read-only mode via the communications software.
This function is set via the DIP switch only, as the function has no other parameters.

7.4.2 Functions II

- Activation and parameter setting via communications software

Additional function	Effect
Standard signal for set-point value <i>INPUT</i>	Select set-point value standard signal.
Effective direction of the actuator <i>DIR.ACTUATOR</i>	Assignment of the aeration state of the actuator chamber to the actual position.
Signal split range <i>SPLITRANGE</i>	Standard signal as % for which the valve runs through the entire mechanical stroke range.
Mechanical stroke range limit <i>X.LIMIT</i>	Limit the mechanical stroke range.
Opening and closing time <i>X.TIME</i>	Limit the control speed.
Positioner <i>X.CONTROL</i>	Parameterize the positioner.
Safety position <i>SAFEPOSITION</i>	Definition of the safety position.
Signal level fault detection <i>SIGNAL ERROR</i>	Configuration of signal level fault detection.
Binary input <i>BINARY INPUT</i>	Configuration of the binary input.
Analog output <i>OUTPUT</i>	Configuration of the analog output (optional).
Reset <i>RESET</i>	Reset to factory settings.

Table 3: Functions II

7.5 Interfaces of the positioner

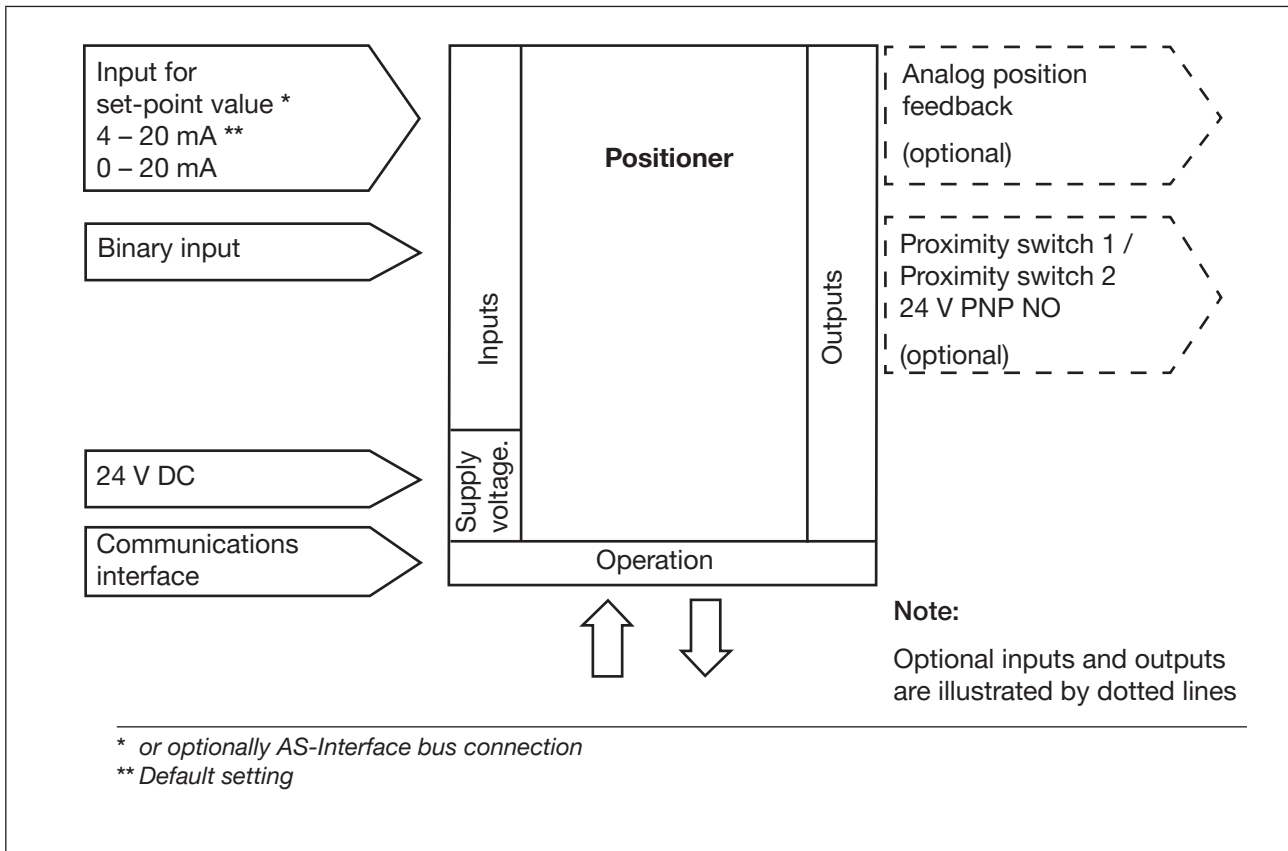

Figure 5: Interfaces of the positioner



The positioner Type 8791 is a 3-wire device, i.e. the power (24 V DC) is supplied separately from the set-point value signal.

- Input for nominal position value (4 – 20 mA corresponds to 0 – 100%) (depends on the position of DIP switch 1).
- Binary input
When applying voltage of > 10 V, *SAFEPOS* will be activated, i.e. the valve is moved into the safety position.
- Analog position feedback (optional)
The position of the valve can be relayed to the PLC via an analog 4 – 20 mA output (4 – 20 mA corresponds to 0 – 100%).

8 TECHNICAL DATA

8.1 Conformity

In accordance with the EU Declaration of conformity, the positioner Type 8791 is compliant with the EU Directives (if applicable).

8.2 Standards

The applied standards on the basis of which compliance with the EU Directives is confirmed are listed in the EU type examination certificate and/or the EU Declaration of Conformity (if applicable).

8.3 Operating conditions



WARNING!

Solar radiation and temperature fluctuations may cause malfunctions or leaks.

- ▶ If the device is used outdoors, do not expose it unprotected to the weather conditions.
- ▶ Ensure that the permitted ambient temperature does not exceed the maximum value or drop below the minimum value.

Ambient temperature	see type label
Protection class	IP65 / IP67 ²⁾ according to EN 60529 (only if cables, plugs and sockets have been connected correctly) 2) <i>If the positioner is used under IP67 conditions, the ventilation filter (see "Figure 1: Structure, positioner type 8791") must be removed and the exhaust air conducted into the dry area.</i>
Altitude	up to 2000 m above sea level

8.4 Mechanical data

Dimensions	See data sheet
Material	
Housing material	Plastic-coated aluminium
Other external parts	Stainless steel (V4A), PC, PE, POM, PTFE
Sealing material	EPDM, NBR, FKM
Weight	approx. 1.0 kg

8.5 Electrical data

8.5.1 Electrical data 24 V DC

Connections	2 cable glands (M20 x 1.5) with screw-type terminals 0.14 – 1.5 mm ² or circular plug-in connector (M12, 8 pole plug)
Interfaces	Communications interface USB: Direct connection to PC via USB adapter. Communication with communications software. An external adapter with integrated interface driver is required. (see chapter “17 Accessories”)
Supply voltage	24 V DC ± 10% max. residual ripple 10%
Power consumption	< 3.5 W
Input resistance for set-point value signal	180 Ω in 0/4 – 20 mA / Resolution 12 bit
Protection class	III in accordance with DIN EN 61140 (VDE 0140-1)
Analog position feedback max. Burden (load) for current output 0/4 – 20 mA)	560 Ω
Inductive proximity switches	100 mA current limit
Binary input	0 – 5 V = log “0”, 10 – 30 V = log “1” inverted input in reverse order (input current < 6 mA)

8.5.2 Electrical data with AS-Interface bus control (optional)

Connections	circular plug-in connector (M12, 4 pole plug)
Supply voltage	29.5 V – 31.6 V DC (according to specification)
Units without external supply voltage:	
Max. power consumption	150 mA
Units with external supply voltage:	
External supply voltage	24 V ± 10 %
The supply voltage unit must feature a secure disconnection in accordance with IEC 364-4-41 (PELV or SELV)	
Max. power consumption	100 mA
Max. power consumption from AS-Interface	50 mA

8.6 Pneumatic data

Control medium	Neutral gases, air Quality classes in accordance with ISO 8573-1
Dust content	Quality class 7 max. particle size 40 µm, max. particle density 10 mg/m ³
Water content	Quality class 3 max. pressure dew point - 20 °C or min. 10 degrees below the lowest operating temperature
Oil content	Quality class X max. 25 mg/m ³
Temperature range of compressed air	0 – +60 °C
Pressure range	1.4 – 7 bar
Air flow rate	95 l _N / min (at 1.4 bar ³⁾) for aeration and deaeration 150 l _N / min (at 6 bar ³⁾) for aeration and deaeration (Q _{Nn} = 100 l _N / min (according to definition for pressure drop from 7 to 6 bar absolute)).
Connections	Internal thread G1/4“

8.7 Safety end positions after failure of the electrical or pneumatic auxiliary power

The safety end position depends on the fluid connection of the actuator to the working connections A1 or A2.

Actuator system	Designation	Safety end positions after failure of the	
		electrical auxiliary power	pneumatic auxiliary power
	single-acting Control function A	down → Connection according to “Figure 6”	down
		up → Connection according to “Figure 7”	
	single-acting control function B	up → Connection according to “Figure 6”	up
		down → Connection according to “Figure 7”	
	double-acting Control function I	→ Fluid connection see “Figure 8”	not defined
		up = lower chamber of the actuator to A2	
		down = upper chamber of the actuator to A2	

Table 4: Safety end positions

Fluid connection: Description for [“Table 4”](#)

Single-acting actuators Control function A and B	Double-acting actuators Control function I
<p>Connection: working connection A1 to actuator A2 sealing</p>	<p>Connection: working connection A2 to actuator A1 sealing</p>
<p>Connection: Working connection A1 and A2 to actuator</p> <p>Safety end position: up = lower chamber to A2 down = upper chamber to A2</p>	

Figure 6: Connection A1

Figure 7: Connection A2

Figure 8: Connection with CFI

MAN 1000335622 EN Version: D Status: RL (released | freigegeben) printed: 28.02.2026

8.8 Factory settings of the positioner

8.8.1 Functions can be activated via DIP switches

Function	Parameter	Value
CUTOFF	Sealing function below	2 %
	Sealing function above	98 %
CHARACT	Select characteristic	FREE
DIR.CMD	Effective direction set-point value	increasing

Table 5: Factory settings; Functions can be activated via DIP switches

8.8.2 Functions can be activated via communications software

Function	Parameter	Value
INPUT	Set-point value input	4 – 20 mA
DIR.ACTUATOR	Effective direction actual value	increasing
SPLITRANGE	Signal split range below	0 %
	Signal split range above	100 %
X.LIMIT Function deactivated	Stroke limit below	0 %
	Stroke limit above	100 %
X.TIME Function deactivated	Actuating time Open	(1 s) values determined by X.TUNE
	Actuating time Closed	(1 s) values determined by X.TUNE After implementation of RESET: 1 s
X.CONTROL	Dead band	1,0 %
	Open amplification factor	(1) values determined by X.TUNE
	Close amplification factor	(1) values determined by X.TUNE After implementation of RESET: 1
SAFEPOSITION	Safety position	0 %
SIGNAL ERROR	Sensor break detection set-point value	OFF
BINARY INPUT Function active	Binary input function	Safety position
	Operating principle of binary input	Normally open contact
OUTPUT Function active	Norm signal output: Parameter	Position
	Norm signal output: Type	4 – 20 mA

Table 6: Factory settings; Functions can be activated via communications software

9 OPERATING

9.1 Safety instructions



WARNING!

Risk of injury from improper operation!

Improper operation may result in injuries as well as damage to the unit and the area around it.

- ▶ The operating personnel must know and have understood the contents of the operating instructions.
- ▶ Observe the safety instructions and intended use.
- ▶ Only adequately trained personnel may operate this equipment.

9.2 Operating status

AUTOMATIC (AUTO)

Normal controller mode is implemented and monitored in AUTOMATIC operating status.

→ LED 1 (MODE) flashes green.

MANUAL

In MANUAL operating status the valve can be opened and closed manually via the keys.

→ LED 1 (MODE) flashes green.

→ LED 3 (FAULT) flashes red.

DIP switch 4 can be used to switch between the two operating statuses AUTOMATIC and MANUAL (see chapter [“9.3.2 Function of the DIP switches”](#)).

9.3 Control and display elements of the positioner

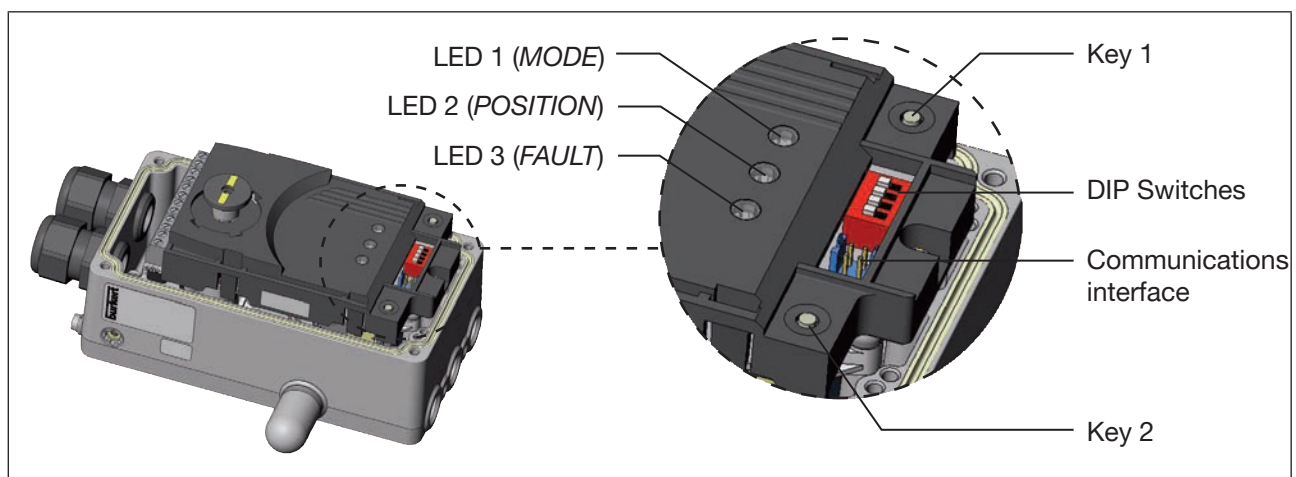

Figure 9: Description of control elements

The positioner features 2 keys, 4 DIP switches and 3 LEDs as a display element.

9.3.1 Configuration of the keys

The configuration of the 2 keys inside the housing varies depending on the operating status (AUTOMATIC / MANUAL).

The description of the operating status (AUTOMATIC / MANUAL) can be found in the chapter entitled [“9.2 Operating status”](#).

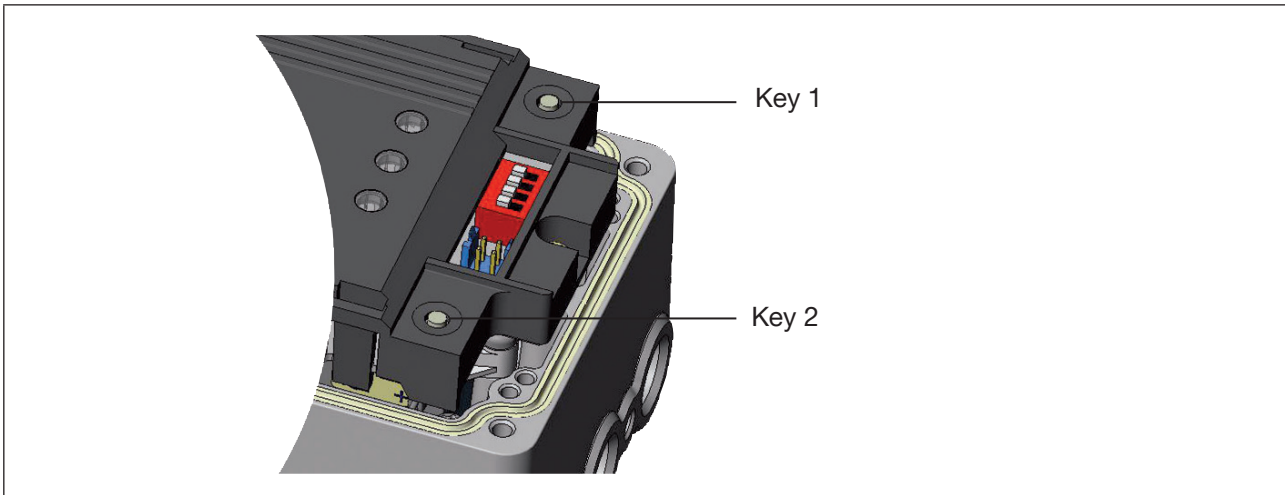

Figure 10: Description of the keys

MANUAL operating status (DIP switch 4 set to ON):

Key	Function
1	Aerate ⁴⁾ (manually open / close the actuator) ⁵⁾
2	Deaerate ⁴⁾ (manually open / close the actuator) ⁵⁾
<p>4) No function if the binary input was activated with the “MANUAL / AUTOMATIC change-over” via the communications software.</p> <p>5) Depending on the control function of the actuator.</p>	

Table 7: Configuration of the keys for MANUAL operating status

AUTOMATIC operating status (DIP switch 4 set to OFF):

Key	Function
1	Press for 5 seconds to start the X.TUNE function
2	-

Table 8: Configuration of the keys for AUTOMATIC operating status

9.3.2 Function of the DIP switches

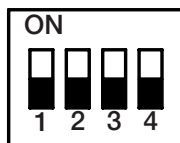

DIP Switches	Position	Function
1	ON	Reversal of the effective direction of the set-point value (<i>DIR.CMD</i>) (set-point value 20 – 4 mA corresponds to position 0 – 100%)
	OFF	Normal effective direction of the set-point value (set-point value 4 – 20 mA corresponds to position 0 – 100%)
2	ON	Sealing function active. The valve completely closes below 2% ⁶⁾ and opens above 98% of the set-point value (<i>CUTOFF</i>)
	OFF	No sealing function
3	ON	Correction characteristic for adjustment of the operating characteristic (Linearization of the operating characteristic <i>CHARACT</i>) ⁷⁾
	OFF	Linear characteristic
4	ON	MANUAL operating status manual
	OFF	AUTO AUTOMATIC operating status

6) Factory setting can be changed via communications software.
7) Characteristic type can be changed via communications software.

Table 9: Function of the DIP switches



Information about the communications software:

The switching position of the DIP switch has priority over the communications software!

If the values of the sealing function (*CUTOFF*) or the correction characteristic (*CHARACT*) are changed via the communication software, the corresponding function must be active (DIP switch set to ON).

The effective direction of the set-point value (*DIR.CMD*) can be changed via the Dip switches.

9.3.3 Display of the LEDs

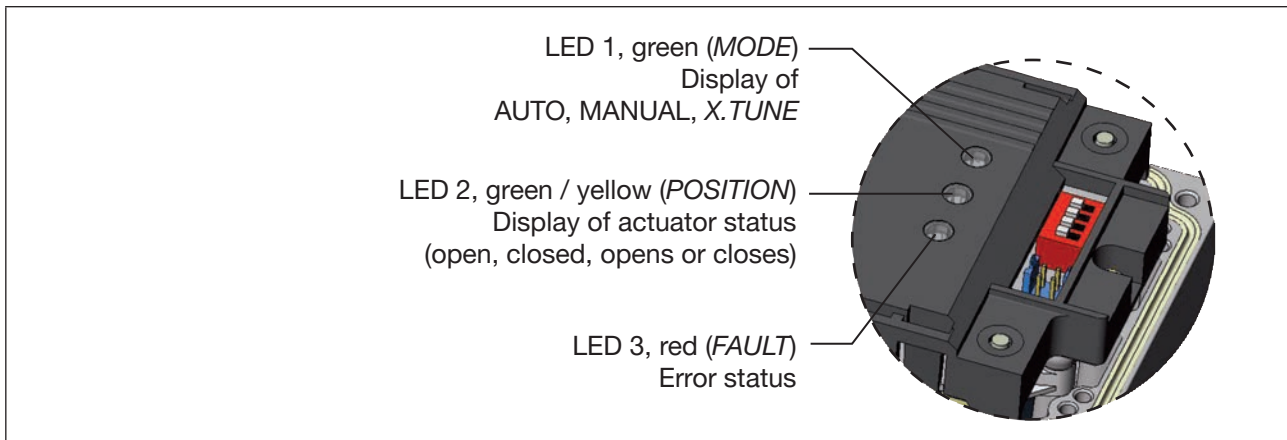

Figure 11: LED display

LED 1 (green, *MODE*) and LED 3 (red, *FAULT*)

LED Status		Display
green	red	
on	off	Acceleration phase when Power ON
flashes slowly	off	Operating status AUTO operating status
flashing alternating	flashing	Operating status MANUAL
flashes quickly	off	X.TUNE function
off	on	FAULT (see chapter entitled “9.4 Error messages”)
flashing slowly	flashing	AUTO operating status for sensor break detection

Table 10: LED Status, LED 1 and LED 3

LED 2 (green / yellow, *POSITION*)

LED Status		Display
green	yellow	
on	off	Actuator closed
off	on	Actuator open
flashes slowly	off	Constant control deviation (actual value > nominal value)
off	flashes slowly	Constant control deviation (actual value > nominal value)
flashes quickly	off	Closing in operating status MANUAL
off	flashes quickly	Opening in operating status MANUAL

Table 11: LED Status, LED 2

9.4 Error messages

9.4.1 Error messages in MANUAL and AUTOMATIC operating status

Display	Cause of fault	Remedial action
LED 3 (red, <i>FAULT</i>) on	Checksum error in data memory → Data memory defective → The device automatically switches to an older (possibly not current) data record.	not possible, device defective. Contact your Bürkert sales office.

Table 12: Error messages in MANUAL and AUTOMATIC operating status

9.4.2 Error messages while the X.TUNE function is running

Display	Cause of fault	Remedial action
LED 3 (red, <i>FAULT</i>) on	No compressed air connected	Connect compressed air
	Compressed air failure during the X.TUNE	Check compressed air supply
	Actuator or control system deaeration side leaking	not possible, device defective
	Control system aeration side leaking	not possible, device defective
	The angular range of the position sensor exceeds 150°	Correct the attachment of the shaft for the position sensor on the actuator (see chapter “11.2.2” and “11.3.2”).

Table 13: Error messages while the X.TUNE function is running

10 FUNCTIONS

The positioner type 8791 has different basic and additional functions which can be configured and parameterized via the DIP switches or the communications software.

10.1 Basic functions

The following basic functions can be activated via the DIP switches (*CUTOFF* and *CHARACT*) or changed (*DIR.CMD*).

Function	Description	DIP switches	OFF	ON
<i>DIR.CMD</i>	Effective sense of direction between input signal and set-point position	1	Ascending	Descending
<i>CUTOFF</i>	Sealing function for positioner	2	Sealing function off	Sealing function on
<i>CHARACT</i>	Selection of the transfer characteristic between input signal and stroke (correction characteristic)	3	Linear characteristic	Correction characteristic

Table 14: Basic functions of DIP switches

The following basic functions can be changed via the communications software only.

Function	Description	Factory settings
<i>INPUT</i>	Input of the standard signal input for the set-point default	4 to 20 mA
<i>RESET</i>	Reset to factory settings	
<i>X.TUNE</i>	Automatic adjustment of the positioner to the relevant operating conditions	

Table 15: Basic functions of communications software

The *INPUT*, *CUTOFF* and *CHARACT* functions can be parameterized via the communications software.

10.1.1 *DIR.CMD* - Effective sense of direction of the positioner set-point value

Use this function to set the effective sense of direction between the input signal (INPUT) and the set-point position of the actuator.

Factory settings: DIP switch set to OFF (ascending)

DIP switches	Position	Function
1	ON	Reversal of the effective sense of direction of the set-point value (<i>DIR.CMD</i>) Set-point value (20 – 4 mA corresponds to position 0 – 100 %), descending
	OFF	Normal effective sense of direction of the set-point value (Set-point value 4 – 20 mA corresponds to position 0 – 100 %), ascending

Table 16: *DIP switches 1*



The effective sense of direction (*DIR.CMD*) can be changed only via DIP switch 1 in the positioner.

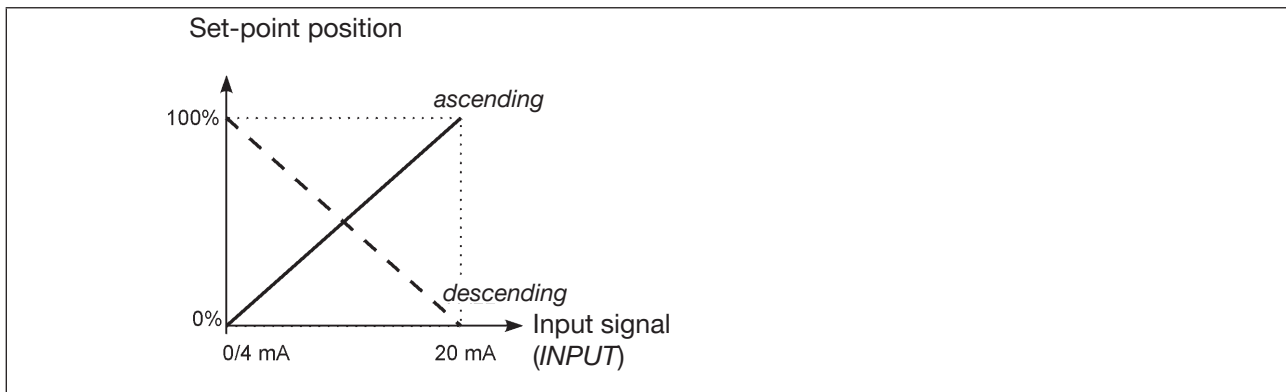

Figure 12: *DIR.CMD graph*

10.1.2 CUTOFF - Sealing function for the positioner

This function causes the valve to be sealed outside the control range.
Controlled operation is resumed with a hysteresis of 1 %.

Factory settings: DIP switch 2 set to OFF (no sealing function)

DIP switches	Position	Function
2	ON	Sealing function active. The valve completely closes below 2 % ⁸⁾ and opens above 98 % of the set-point value (CUTOFF)
	OFF	No sealing function

Table 17: DIP-switch 2

The communications software can be used to change the limits for the position set-point value as a percentage.



The switching position of the DIP switches in the positioner has priority over the communications software, i.e. settings of the sealing function (CUTOFF) which are changed via the communications software are not active unless DIP switch 2 in the positioner is set to ON.

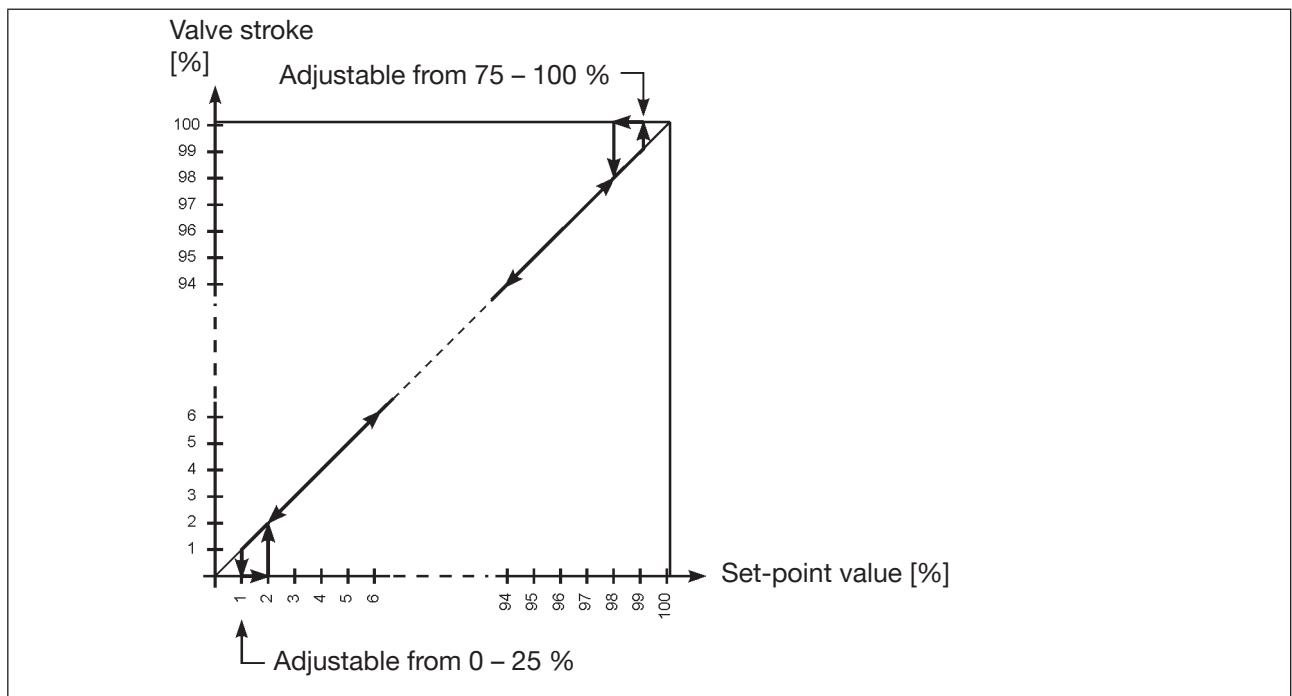

Figure 13: CUTOFF graph

8) Factory settings can be changed via communications software.

10.1.3 CHARACT - Transfer characteristic between input signal (position set-point value) and stroke

Characteristic (customer-specific characteristic)

This function can be used to activate a transfer characteristic with respect to set-point value (set-point position) and valve stroke for correction of the flow or operating characteristic.



The transfer characteristic can be changed via the communications software only.

Factory settings: DIP switch 3 set to OFF (linear)

DIP switches	Position	Function
3	ON	Correction characteristic for adjustment of the operating characteristic (linearization of the process characteristic <i>CHARACT</i>) ⁹⁾
	OFF	Linear characteristic

Table 18: DIP switch 3



The switching position of the DIP switches in the positioner has priority over the communications software, i.e. settings of the correction characteristic (*CHARACT*) which are changed via the communications software are not active unless DIP switch 3 in the positioner is set to ON.

Characteristics which can be selected via the communications software:

Characteristic	Description
Linear	Linear characteristic
1 : 25	Equal percentage characteristic 1 : 25
1 : 33	Equal percentage characteristic 1 : 33
1 : 50	Equal percentage characteristic 1 : 50
25 : 1	Inversely equal percentage characteristic 25 : 1
33 : 1	Inversely equal percentage characteristic 33 : 1
55 : 1	Inversely equal percentage characteristic 55 : 1
FREE	User-defined characteristic, freely programmable via nodes

Table 19: Selection of characteristics

⁹⁾ The characteristic type can be changed via the communications software only.

The flow characteristic $k_v = f(s)$ indicates the flow-rate of a valve, expressed by the value k_v as a function of the stroke s of the actuator spindle. It is determined by the design of the valve seat and the seat seal. In general two types of flow characteristics are implemented, the linear and the equal percentage.

In the case of linear characteristics, equal k_v value changes dk_v are assigned to equal stroke changes ds .

$$(dk_v = n_{lin} \cdot ds).$$

In the case of an equal percentage characteristic, an equal percentage change of the k_v value corresponds to a stroke change ds .

$$(dk_v/k_v = n_{eqprct} \cdot ds).$$

The operating characteristic $Q = f(s)$ specifies the correlation between the volumetric flow Q in the installed valve and the stroke s . This characteristic has the properties of the pipelines, pumps and consumers. It therefore exhibits a form which differs from the flow characteristic.

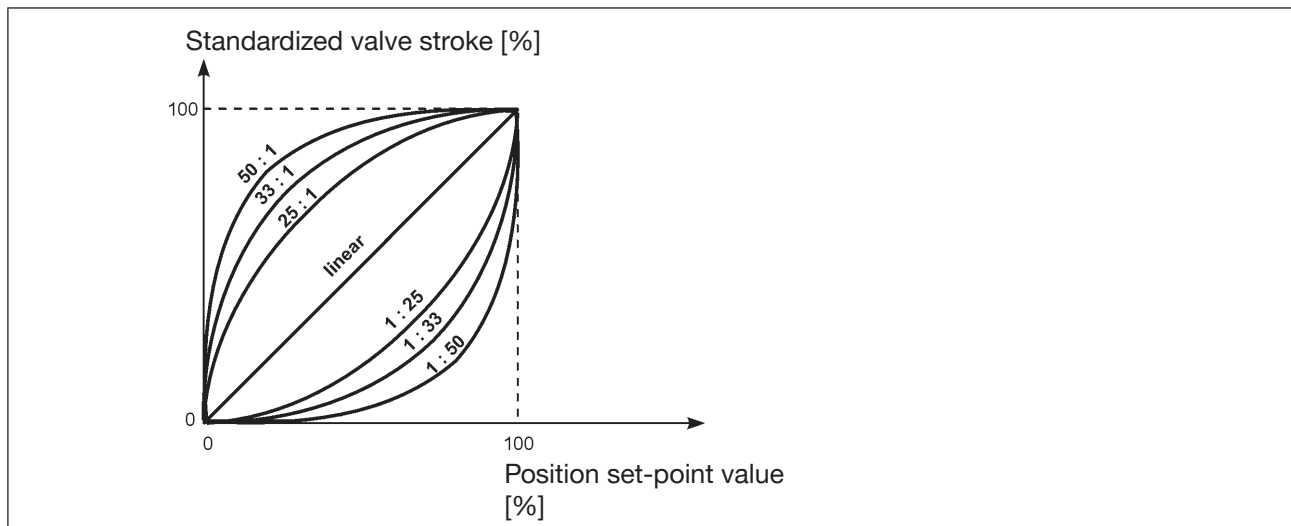

Figure 14: Characteristic

In the case of control tasks for closed-loop control systems it is usually particular demands which are placed on the course of the operating characteristic, e.g. linearity. For this reason it is occasionally necessary to correct the course of the operating characteristic in a suitable way. For this purpose the positioner features a transfer element which implements different characteristics. These are used to correct the operating characteristic.

Equal percentage characteristics 1:25, 1:33, 1:50, 25:1, 33:1, and 50:1 as well as a linear characteristic can be set. A characteristic can be freely programmed using nodes.

Entering the freely programmable characteristic

The characteristic is defined by 21 nodes distributed uniformly over the position set-point values ranging from 0 – 100%. They are spaced at intervals of 5%. A freely selectable stroke (adjustment range 0 – 100%) is assigned to each node. The difference between the stroke values of two adjacent nodes must not be greater than 20%.

Example of a programmed characteristic

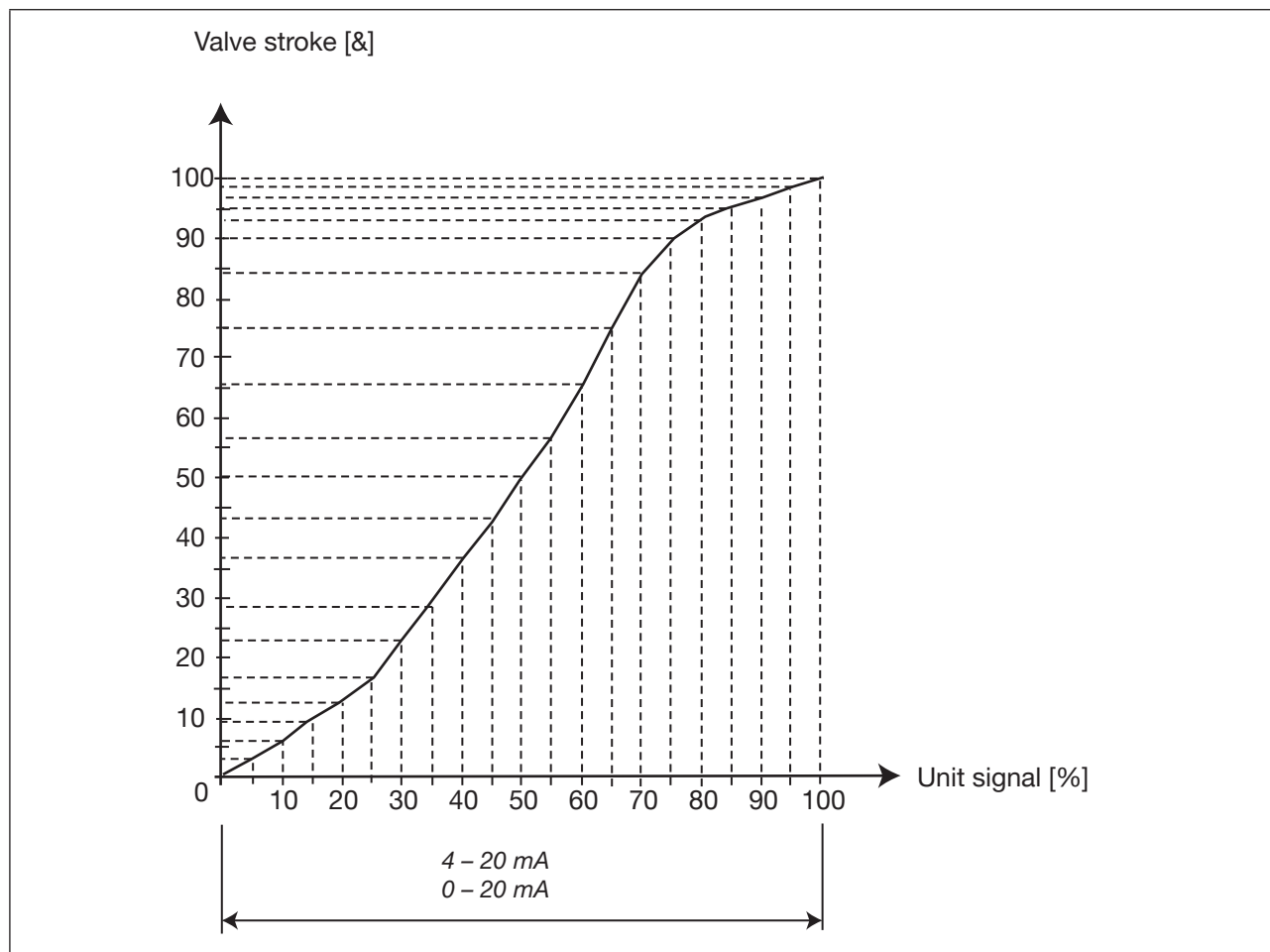

Figure 15: Example of a programmed characteristic

10.1.4 INPUT - Enter the input signal

Under this menu option, enter the unit signal used for the set-point value.

Factory setting: 4 – 20 mA

10.1.5 **RESET -** **Reset to factory settings**

This function can be used to reset the positioner to the factory settings.

10.1.6 **X.TUNE -** **Automatic adjustment of the positioner to the relevant operating conditions**



The *X.TUNE* function must be run for a function check of the positioner to adjust to specific local features.



WARNING!

While the *X.TUNE* function is running, the valve automatically moves from its current position.

- ▶ Never run *X.TUNE* while a process is running.
- ▶ Take appropriate measures to prevent the system / positioner from being unintentionally actuated.

NOTE!

Avoid maladjustment of the controller due to an incorrect compressed air supply or applied operating medium pressure.

- ▶ Run *X.TUNE* **whenever** the compressed air supply (= pneumatic auxiliary energy) is available during subsequent operation.
- ▶ Run the *X.TUNE* function preferably **without** operating medium pressure to exclude interference caused by flow forces.



To run *X.TUNE*, the positioner must be in the AUTOMATIC operating state (DIP switch 4 = OFF).

→ Set up *TUNE* / *TUNE* Functions.

→ Start *X.TUNE*. To do this, click „Start *X.TUNE*“ ²⁾.

The progress of *X.TUNE* is shown in the communication software:

When the automatic adjustment completes, a message appears.

The changes are automatically transferred to the positioner's memory (EEPROM) after the *X.TUNE* function is successful.

10.2 Additional functions

The following additional functions can be configured and parameterized via the communications software:

Function	Description
<i>DIR.ACTUATOR</i>	Assignment of the aeration state of the actuator chamber to the actual position.
<i>SPLITRANGE</i>	Signal split range; input signal as % for which the valve runs through the entire stroke range.
<i>X.LIMIT</i>	Limit of the mechanical stroke range.
<i>X.TIME</i>	Limiting the control speed.
<i>X.CONTROL</i>	Parameterization of the positioner.
<i>SAFE POSITION</i>	Input the safety position.
<i>SIGNAL ERROR</i>	Configuration of signal level, fault detection.
<i>BINARY INPUT</i>	Activation of the binary input.
<i>OUTPUT</i>	Configuration of the outputs (only with auxiliary board for analogue feedback signal).

Table 20: Overview of additional functions

10.2.1 *DIR.ACTUATOR* - Effective direction of the actuator

Use this function to set the effective direction between the aeration state of the actuator and the actual position.

Factory setting: rise

Rise: Direct effective direction (deaerated → 0 %; aerated 100 %)

Case: Inverse effective direction (deaerated → 100 %; aerated 0 %)

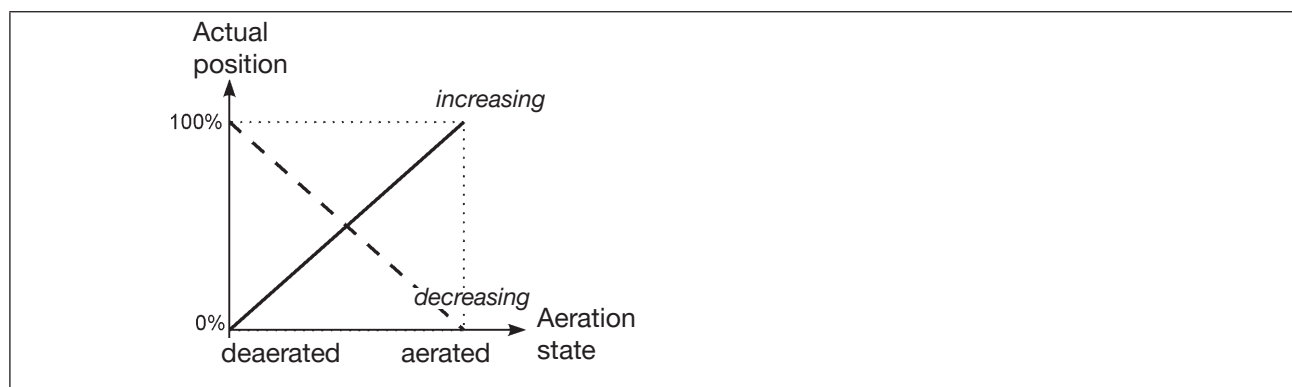

Figure 16: *DIR.ACTUATOR* graph

10.2.2 *SPLTRNG* - Signal split range

Minimum and maximum values of the input signal as a % for which the valve runs through the entire stroke range.

Factory setting: Lower signal range split = 0 %; Upper signal range split = 100 %

Lower value split range: Input the minimum value of the input signal as a %
Adjustment range: 0 – 75 %

Upper value split range: Input the maximum value of the input signal as a %
Adjustment range: 25 – 100 %

Use this function to limit the position set-point value range of the positioner by specifying a minimum and a maximum value. This makes it possible to divide a unit signal range that is used (4 – 20 mA, 0 – 20 mA) into several positioners (without or with overlapping). This allows several valves to be used alternately or, in the case of overlapping set-point value ranges, simultaneously as actuators.

To split a unit signal range into two set-point value ranges:

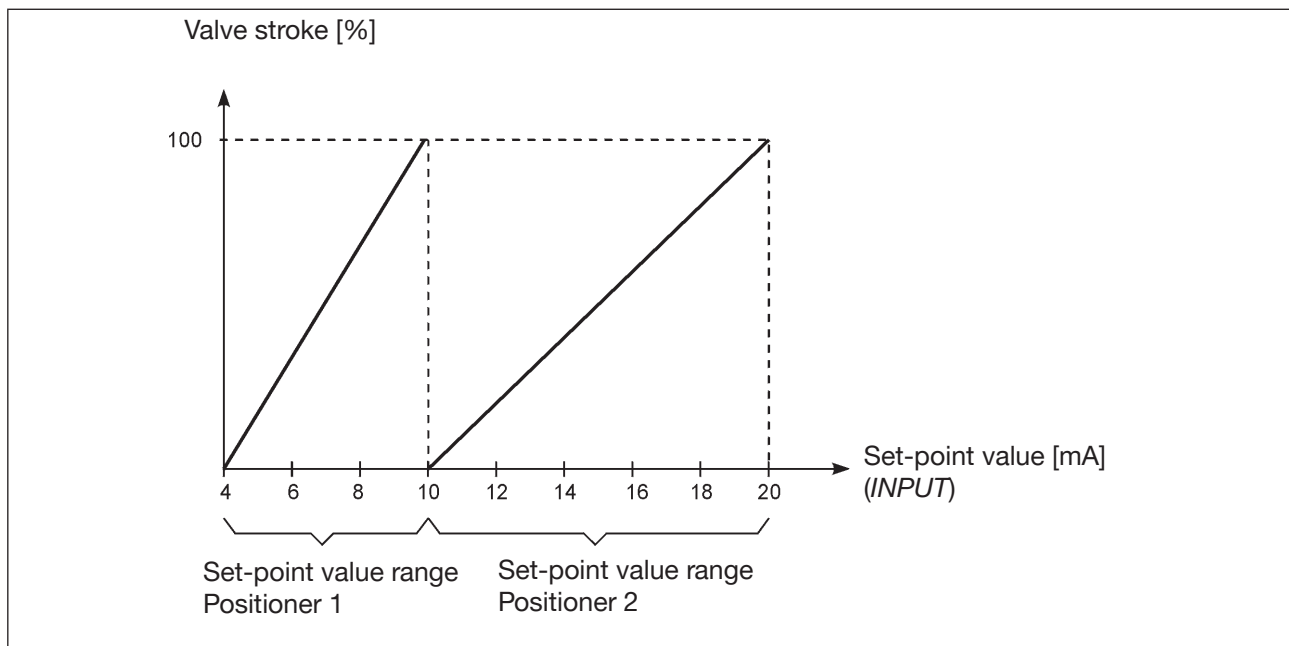

Figure 17: *SPLTRNG* graph

10.2.3 X.LIMIT - Limiting the mechanical stroke range

This function limits the (physical) stroke to specified % values (lower and upper). In doing so, the stroke range of the limited stroke is set equal to 100 %. If the limited stroke range is left during operation, negative actual positions or actual positions greater than 100 % are shown.

Factory setting: Lower position limit = 0 %, upper position limit = 100 %

Adjustment ranges:

Lower position limit: 0 – 50 % of the entire stroke

Upper position limit: 50 – 100 % of the entire stroke

The minimum distance between the upper and lower stroke limit is 50 %. Therefore if one value is entered with a minimum distance of < 50 % the other value is adjusted automatically.

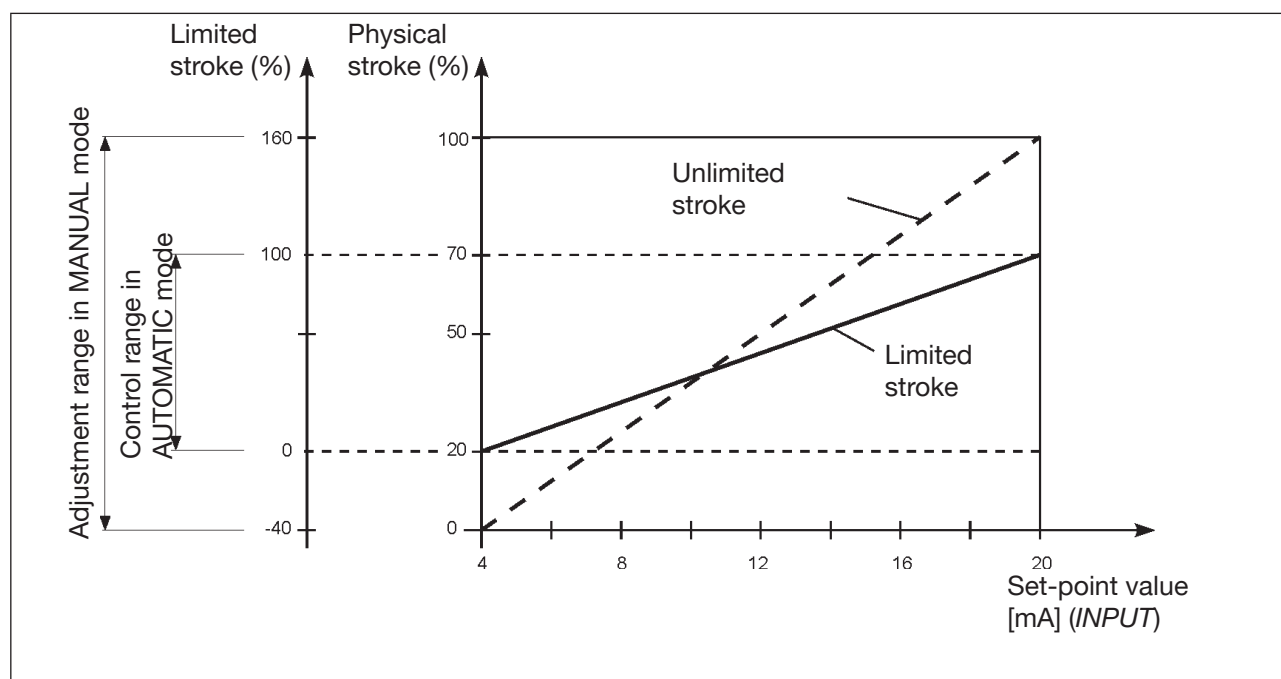

Figure 18: X.LIMIT graph

10.2.4 X.TIME - Limiting the control speed

Use this function to specify the opening and closing times for the entire stroke and thereby limit control speeds.

! When the *X.TIME* function is running, the minimum opening and closing time for the entire stroke is automatically entered for Open and Close. Therefore, movement can be at maximum speed.

Factory setting: values determined at the factory by the *X.TIME* function

If the control speed will be limited, values can be input for Open and Close which are between the minimum values determined by the *X.TIME* and 60 seconds.

Valve timeopen: Opening time for entire stroke (in seconds)
Adjustment range: 1 – 60 seconds

Valve timeclose: Closing time for entire stroke (in seconds)
Adjustment range: 1 – 60 seconds

Effect of limiting the opening speed when there is a jump in the set-point value

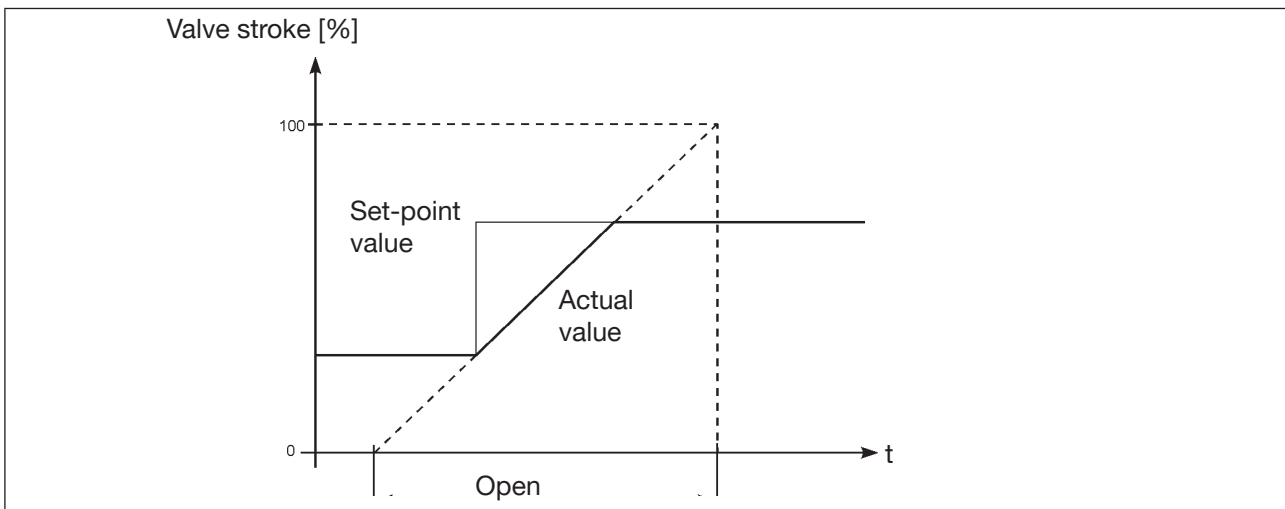

Figure 19: X.TIME graph

10.2.5 X.CONTROL - Parameterization of the positioner

Use this function to set the parameters for the positioner (dead band and amplification factors (kp)).

Deadband: Insensitivity range of the positioner

Entry for the deadband as a % in reference to the scaled stroke range;
i.e. X.LIMIT upper stroke limit - X.LIMIT lower stroke (see auxiliary function X.LIMIT).

This function causes the controller to respond only beginning at a specific control difference. This function saves wear on the solenoid valves in the positioner and the pneumatic actuator.

! If the auxiliary function X.CONTROL is in the main menu while X.TUNE (Autotune of the positioner) is running, the deadband is determined automatically depending on the friction behavior of the actuator drive. The value determined in this way is an approximate value. You can re-adjust it manually.

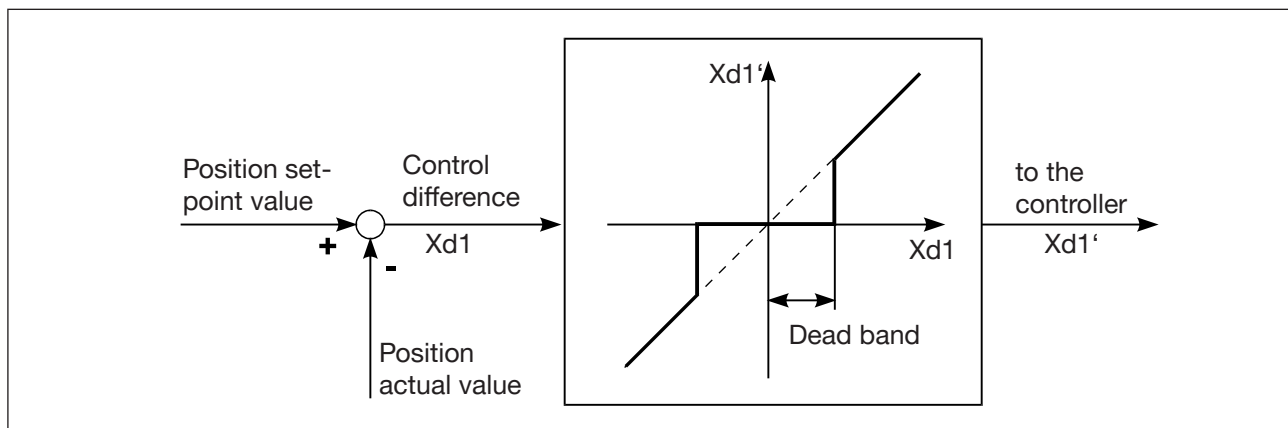

Figure 20: X.CONTROL graph

Open/close amplification factor: Parameters for the positioner

Open amplification factor: Amplification factor of the positioner (for closing the valve)

Close amplification factor: Amplification factor of the positioner (for opening the valve)

10.2.6 SAFE POSITION - Definition of the safe position

This function specifies the actuator safety position which is approached at defined signals.

! The set safety position is only approached if there is a corresponding signal at the binary input (for configuration see *BINARY INPUT*) or if a signal error occurs (for configuration see *SIGNAL ERROR*).

If the mechanical stroke range is limited with the X.LIMIT function, only safety positions within these limits can be approached.

This function is executed in AUTOMATIC mode only.

10.2.7 **SIGNAL ERROR -** Configuration of signal level fault detection

The *SIGNAL ERROR* function is used to detect a fault on the input signal.



Fault detection

Fault detection can be selected for a 4 – 20 mA signal only:

Fault if input signal ≤ 3.5 mA (± 0.5 % of final value, hysteresis 0.5 % of final value)

If 0 – 20 mA is selected, sensor break detection cannot be selected.

A signal error is indicated on the device by the red LED for “setpoint error detection” ON.

Safety position for sensor break ON:

The following configurations can occur with “safety position if setpoint error” ON:

Active *SAFE POSITION*

If a fault is detected, the drive moves to the lower *SAFE POSITION* set position.

Inactive *SAFE POSITION*

If a fault is detected, the drive moves to the end position which it would assume in the isolated state.

10.2.8 **BINARY INPUT -** Activation of the binary input

This function activates the binary input.

The following settings can be implemented for this:

- Approach the safety position
- Switching over the MANUAL/AUTOMATIC operating mode
- Starting the function *X.TUNE* (standard valid since software version A.12).

Safety position

Approach the safety position.

Active *SAFE POSITION* function

the drive moves to the lower *SAFE POSITION* set position.

Inactive *SAFE POSITION*

The drive moves to the end position which it would assume in the isolated state.

Switch over the operating state to MANUAL or AUTOMATIC.

Binary input = 0 → AUTOMATIC operating state

Binary input = 1 → MANUAL operating state

If switching over the operating mode is selected, you can no longer switch the operating mode with DIP switch 4

Starting the function *X.TUNE*

Binary input = 1 → Starting *X.TUNE*.

10.2.9 **OUTPUT (optional) - Configuration of the analog output**

The OUTPUT menu item only appears in the selection of auxiliary functions if the positioner has an analog output (optional) or if no parameters have been read in yet.

The analog output can be used for feedback of the current position or of the set-point value to the control center.

Standard signal output: parameter	Position	Output of the current position
	Set-point value	Output of the set-point value
Standard signal output: type	4 – 20 mA	Selection of the unit signal
	0 – 20 mA	

11 ATTACHMENT AND ASSEMBLY



The dimensions of the positioner and the different device versions can be found on the data sheet.

11.1 Safety instructions



WARNING!

Risk of injury from improper installation.

- ▶ Installation may be carried out by authorised technicians only and with the appropriate tools.

Risk of injury from unintentional activation of the system and an uncontrolled restart.

- ▶ Secure system from unintentional activation.
- ▶ Following assembly, ensure a controlled restart.

11.2 Attachment to a proportional valve with NAMUR linear actuators

The valve position is transferred to the position sensor installed in the positioner via a lever (according to NAMUR).

11.2.1 Attachment kit (IEC 534-6) for linear actuators (order no. 787215)

(Can be purchased as an accessory from Bürkert).

Part no.	Quantity	Name
1	1	NAMUR mounting bracket IEC 534
2	1	Hoop
3	2	Clamping piece
4	1	Driver pin
5	1	Conical roller
6a	1	NAMUR lever for stroke range 3 – 35 mm
6b	1	NAMUR lever for stroke range 35 – 130 mm
7	2	U-bolt
8	4	Hexagon bolt DIN 933 M8 x 20
9	2	Hexagon bolt DIN 933 M8 x 16
10	6	Circlip DIN 127 A8
11	6	Washer DIN 125 B8.4
12	2	Washer DIN 125 B6.4
13	1	Spring VD-115E 0.70 x 11.3 x 32.7 x 3.5
14	1	Spring washer DIN 137 A6
15	1	Locking washer DIN 6799 - 3.2
16	3	Circlip DIN 127 A6
17	3	Hexagon bolt DIN 933 M6 x 25
18	1	Hexagon nut DIN 934 M6
19	1	Square nut DIN 557 M6
21	4	Hexagon nut DIN 934 M8
22	1	Guide washer 6.2 x 9.9 x 15 x 3.5

Table 21: Attachment kit for linear actuators

11.2.2 Installation



WARNING!

Risk of injury from improper installation.

- ▶ Installation may be carried out by authorised technicians only and with the appropriate tools.

Risk of injury from unintentional activation of the system and an uncontrolled restart.

- ▶ Secure system from unintentional activation.
- ▶ Following assembly, ensure a controlled restart.

Procedure:

- Using the bracket (2) the clamping pieces (3), hexagon bolts (17) and circlips (16) attach the hoop to the actuator spindle.

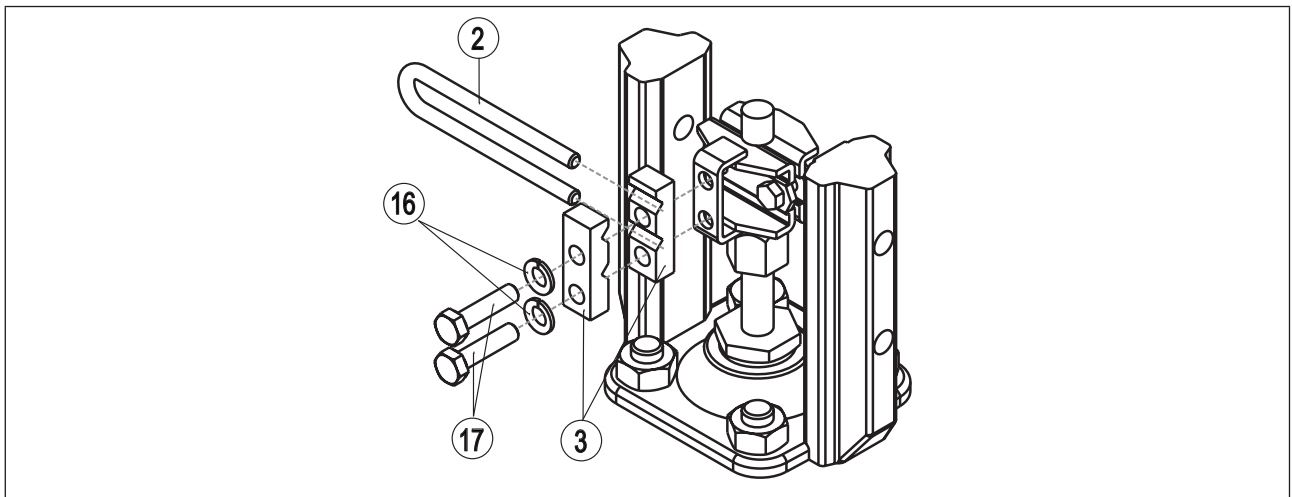

Figure 21: Attaching the hoop

- Select short or long lever according to the stroke of the actuator (see “[Table 21: Attachment kit for linear actuators](#)” part no. 6a/6b).
- Assemble lever (if not pre-assembled) “[Figure 22](#)”.

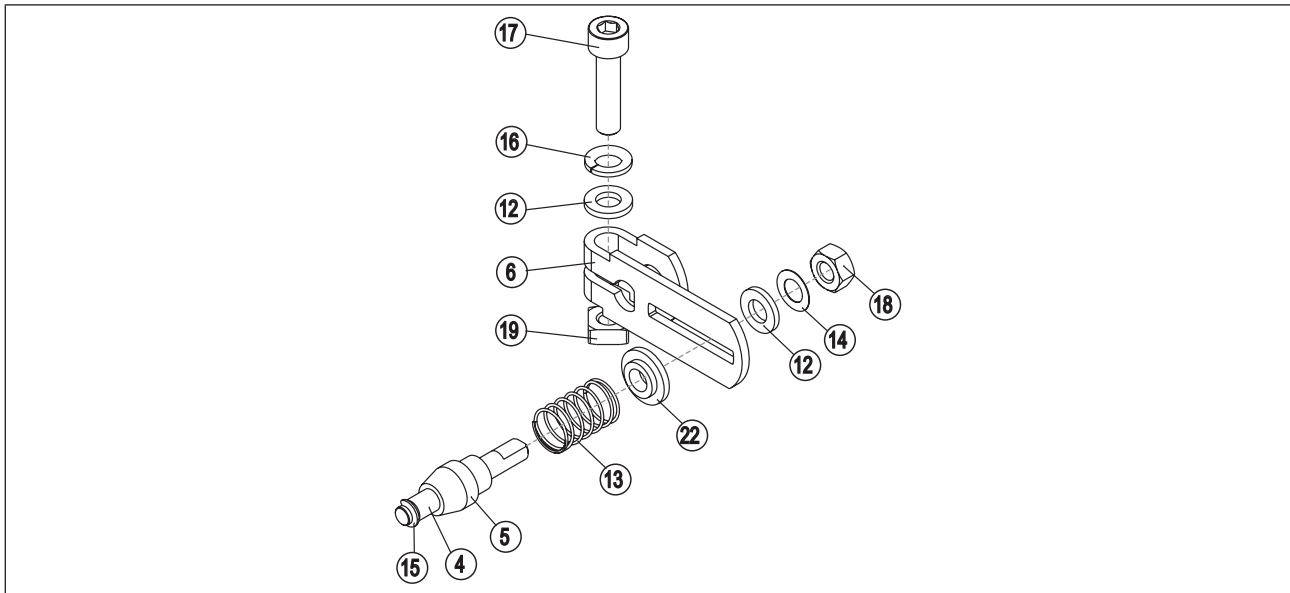

Figure 22: Assembling the lever



The gap between the driver pin and the axle should be the same as the drive stroke. This results in the ideal angular range of the lever of 60° (see “Figure 23”).

Angular range of the position sensor:

The maximum angular range of the position sensor is 150°.

Rotational range of the lever:

To ensure that the position sensor operates at a good resolution, the rotational range of the lever must be at least 30°.

The rotational movement of the lever must be within the position sensor angular range of 150°.

The scale printed on the lever is not relevant.

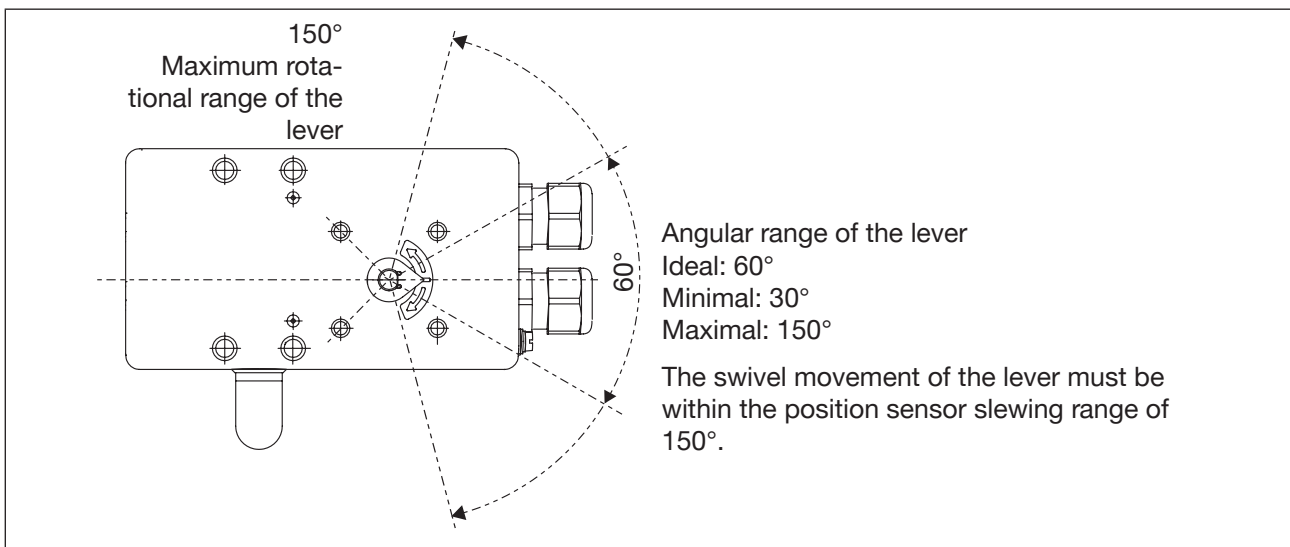

Figure 23: Rotational range of the lever

→ Attach lever to the axle of the positioner and screw tight (17) and (19).

11.2.3 Attaching mounting bracket

→ Attach mounting bracket ① to the back of the positioner with hexagon bolts ⑨, circlip ⑩ and washers ⑪ (see “Figure 24”).



The selection of the M8 thread used on the positioner depends on the size of the actuator.

→ To determine the correct position, hold the positioner with mounting bracket on the actuator.

The conical roller on the lever of the position sensor in the hoop must be able to run freely on the drive over the entire stroke range.

At 50% stroke the lever position should be approximately horizontal (see chapter “11.2.4 Aligning lever mechanism”).

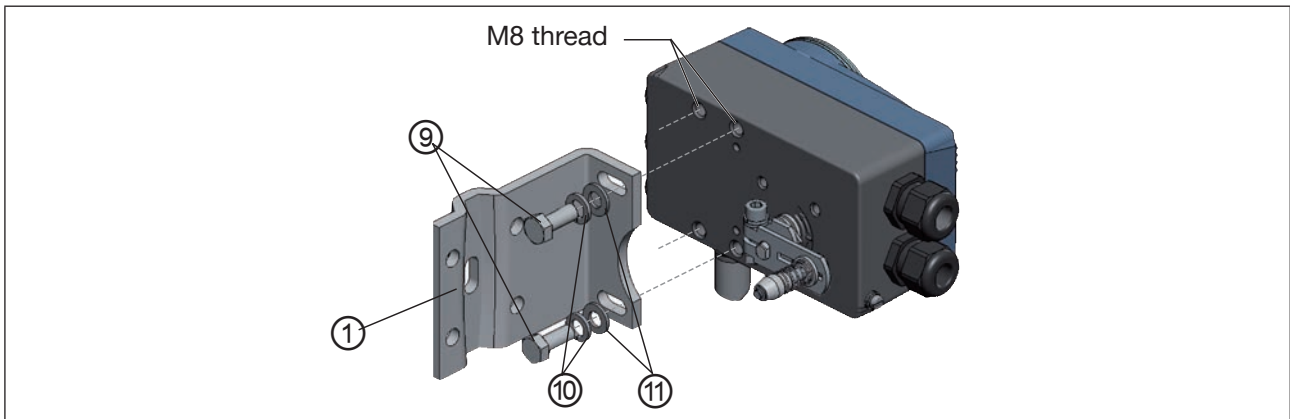

Figure 24: Attaching mounting bracket

Attaching the positioner with mounting bracket for actuators with cast frame:

→ Attach mounting bracket to the cast frame with one or more hexagon bolts ⑧, washers ⑪ and circlips ⑩ (see “Figure 25”).

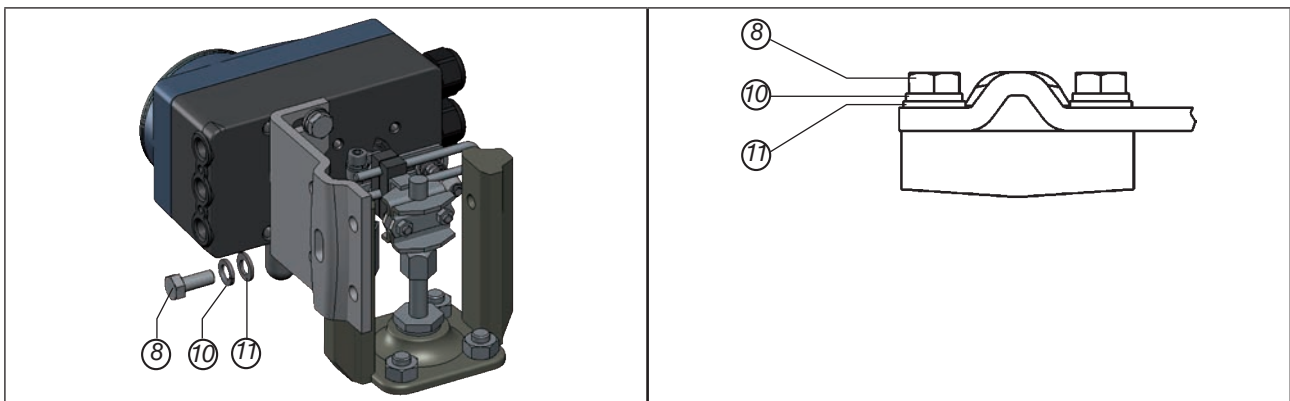

Figure 25: Attach positioner with mounting bracket; for actuators with cast frame

Attaching the positioner with mounting bracket for actuators with columnar yoke:

→ Attach mounting bracket to the columnar yoke with the U-bolt ⑦, washers ⑪, circlips ⑩ and hexagon nuts ⑫ (see “Figure 26”).

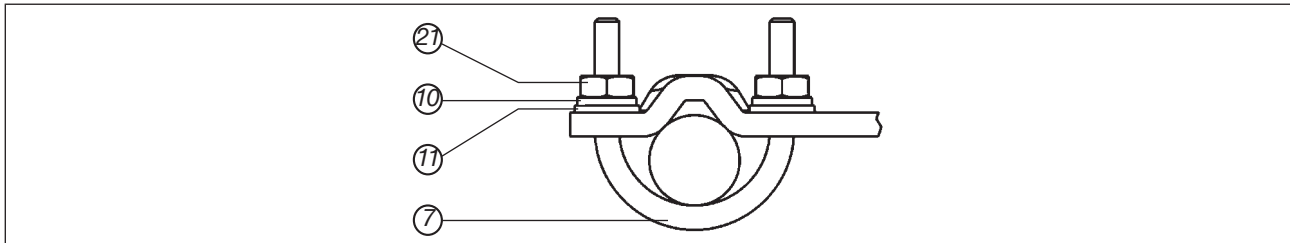

Figure 26: Attach positioner with mounting bracket; for actuators with columnar yoke

11.2.4 Aligning lever mechanism



The lever mechanism cannot be correctly aligned until the device has been connected electrically and pneumatically.

- Move the actuator in manual mode to half stroke (according to the scale on the actuator).
- Adjust the height of the positioner until the lever is horizontal.
- Fix the positioner in this position on the actuator.

11.3 Attachment to a proportional valve with rotary actuator

The axle of the position sensor integrated in the positioner is connected directly to the axle of the rotary actuator.

11.3.1 Attachment kit (VDI/VDE 3845) on rotary actuator (order no. 787338)

(Can be purchased as an accessory from Bürkert).

Part no.	Quantity	Name
1	1	Adapter
2	2	Setscrew DIN 913 M4 x 10
3	4	Cheese-head screw DIN 933 M6 x 12
4	4	Circlip B6
5	2	Hexagon nut DIN 985, M4

Table 22: Attachment kit on rotary actuator

Other accessories:

The assembly bridge with fastening screws (according to VDI/VDE 3845) can be purchased from Bürkert as an accessory by quoting the identification number 770294.

11.3.2 Installation



WARNING!

Risk of injury from improper installation.

- ▶ Installation may be carried out by authorised technicians only and with the appropriate tools.

Risk of injury from unintentional activation of the system and an uncontrolled restart.

- ▶ Secure system from unintentional activation.
- ▶ Following assembly, ensure a controlled restart.

Procedure:

- Specify the attachment position of the positioner:
 - parallel to the actuator or
 - rotated by 90° to the actuator.
- Determine home position and direction of rotation of the actuator.

**Anti-twist safeguard:**

Note the flat side of the axle!

One of the setscrews must be situated on the flat side of the axle as an anti-twist safeguard (see "Figure 27").

Angular range of the position sensor:

The maximum angular range of the position sensor is 150°.

The axle of the positioner may be moved within this range only.

→ Connect adapter ① to the axle of the positioner and secure with 2 setscrews.

→ Secure setscrews with self-locking nuts to prevent them from working loose.

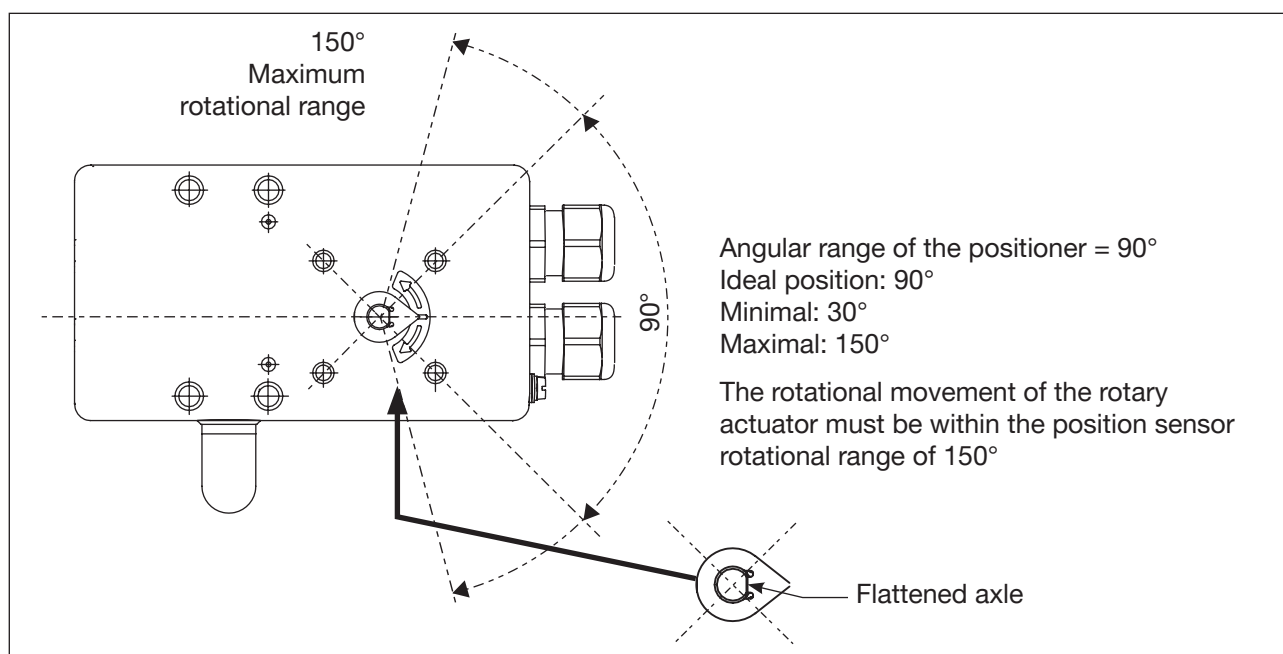

Figure 27: Angular range / anti-twist safeguard

→ Assemble the multi-part assembly bridge¹⁰⁾ suitable for the actuator.

→ Attach the assembly bridge to the positioner using 4 cheese-head screws ③ and circlips ④. (see "Figure 28").

10) The assembly bridge consists of 4 parts which can be adjusted to the actuator by varying the arrangement.

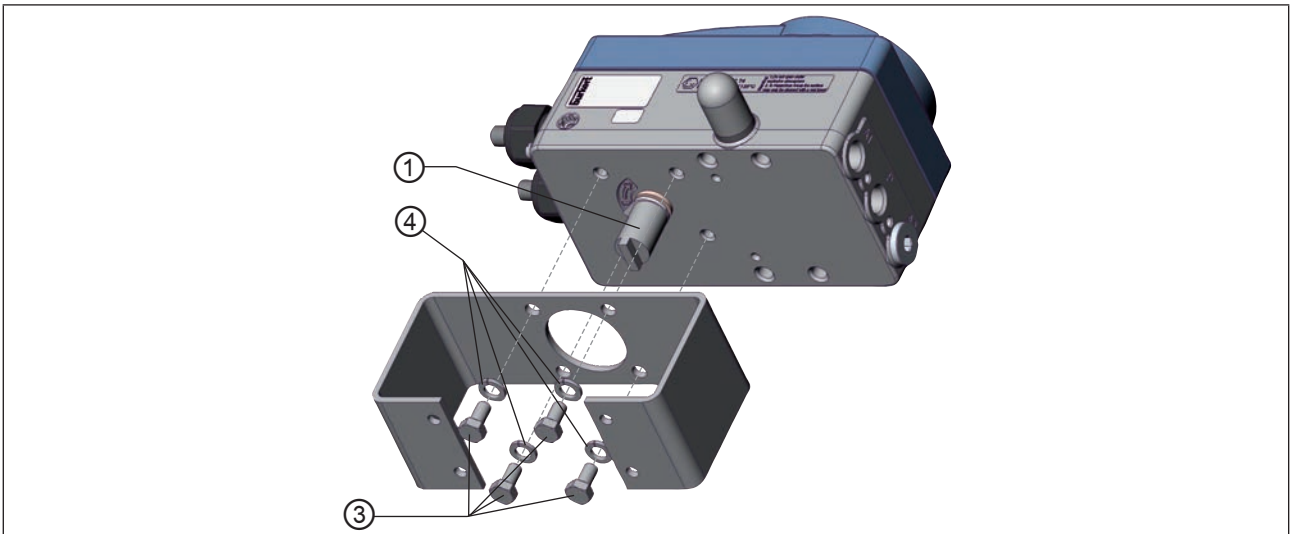

Figure 28: Attach assembly bridge (schematic representation)

→ Place positioner with assembly bridge on the rotary actuator and attach (see “Figure 29”).

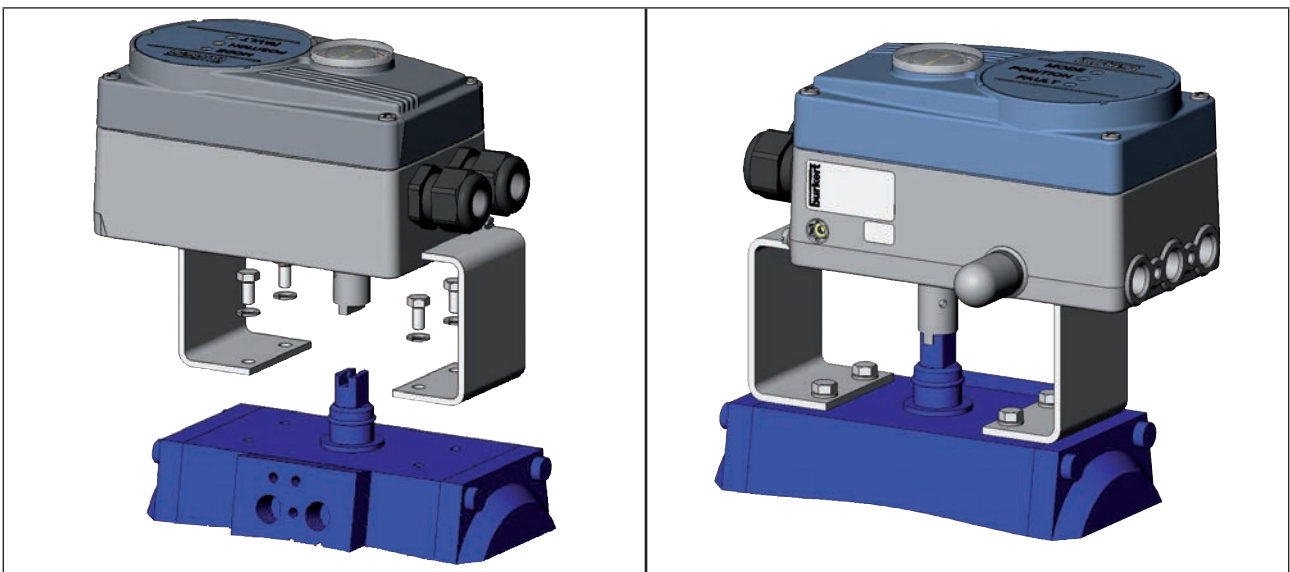

Figure 29: Rotary actuator attachment

11.4 Remote operation with external position sensor

In the case of this model the positioner has no position sensor in the form of a rotary position sensor, but an external remote sensor.

The Remote-Sensor Type 8798 is connected via a serial, digital interface.

11.4.1 Mounting accessories

There are two options of attaching the positioner in remote operation (see “Figure 30”).

Installation on a DIN rail with accessory kit,
part no. 675702

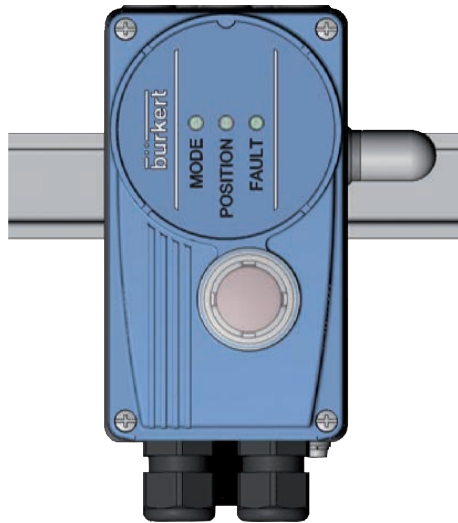

Installation on a wall with accessory kit,
part no. 675715

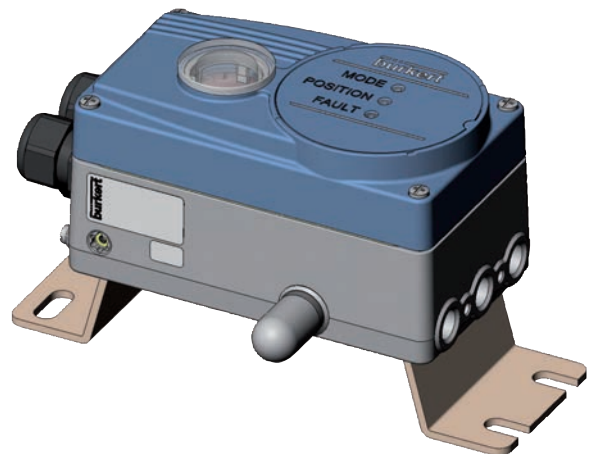

Figure 30: Attachment types in remote operation

11.4.2 Connection and start-up of the Remote-Sensor Type 8798



WARNING!

Risk of injury from improper start-up.

- ▶ Start-up may be carried out by authorised technicians only and with the appropriate tools.

Risk of injury from unintentional activation of the system and an uncontrolled restart.

- ▶ Secure system from unintentional activation.
- ▶ Following assembly, ensure a controlled restart.

→ Connect the 4 wires of the sensor cable to the designated screw-type terminals of the positioner (see chapter [“13.3.6 Terminal assignment for external position sensor \(for remote model only\)”](#)).

→ Attach remote sensor on the actuator.

The correct procedure is described in the brief instructions for the remote sensor.

→ Connect positioner pneumatically to the actuator.

→ Connect compressed air to positioner.

→ Switch on supply voltage to the positioner.

→ Run the *X.TUNE* function.

12 FLUID CONNECTION

12.1 Safety instructions



DANGER!

Risk of injury from high pressure in the equipment/device.

- ▶ Before working on equipment or device, switch off the pressure and deaerate/drain lines.



WARNING!

Risk of injury from improper installation.

- ▶ Installation may be carried out by authorized technicians only and with the appropriate tools.

Risk of injury from unintentional activation of the system and an uncontrolled restart.

- ▶ Secure system from unintentional activation.
- ▶ Following installation, ensure a controlled restart.

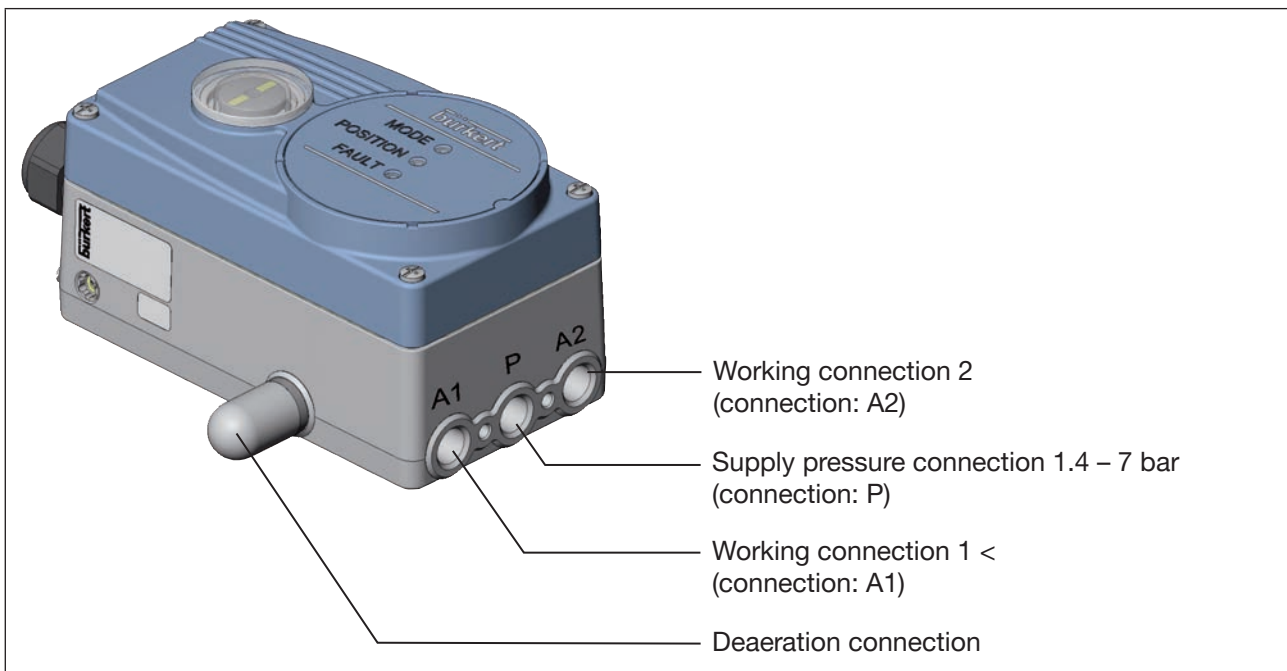

Figure 31: Fluid installation / Location of the connections

Procedure:

→ Apply supply pressure (1.4 – 7 bar) to the supply pressure connection P.

For single-acting actuators (Control function A and B):

→ Connect one working connection (A1 or A2, depending on required safety end position) to the chamber of the single-acting actuator.

Safety end positions see chapter [“8.7 Safety end positions after failure of the electrical or pneumatic auxiliary power”](#).

→ Seal a working connection which is not required with a plug.

For double-acting actuators (Control function I):

→ Connect working connections A1 and A2 to the respective chambers of the double-acting actuator.

Safety end positions see chapter [“8.7 Safety end positions after failure of the electrical or pneumatic auxiliary power”](#).



Important information for perfect control behavior!

This ensures that the control behavior is not extremely negatively affected in the upper stroke range on account of too little pressure difference.

- keep the applied supply pressure at least 0.5 – 1 bar above the pressure which is required to move the pneumatic actuator to its end position.

If fluctuations are greater, the control parameters measured with the *X.TUNE* function are not optimum.

- during operation keep the fluctuations of the supply pressure as low as possible (max. ±10%).

13 ELECTRICAL CONNECTION

All electrical inputs and outputs of the device are not galvanically isolated from the supply voltage.

13.1 Safety instructions

DANGER!

Risk of electric shock.

- ▶ Before working on equipment or device, switch off the power supply and secure to prevent reactivation.
- ▶ Observe applicable accident prevention and safety regulations for electrical equipment.

WARNING!

Risk of injury from improper installation.

- ▶ Installation may be carried out by authorized technicians only and with the appropriate tools.

Risk of injury from unintentional activation of the system and an uncontrolled restart.

- ▶ Secure system from unintentional activation.
- ▶ Following installation, ensure a controlled restart.

13.2 Electrical connection with circular plug-in connector



If AS-Interface:

The designation of the circular plug-in connector and the contacts can be found in chapter [“15 AS-Interface”](#).

13.2.1 Designation of the circular plug-in connector

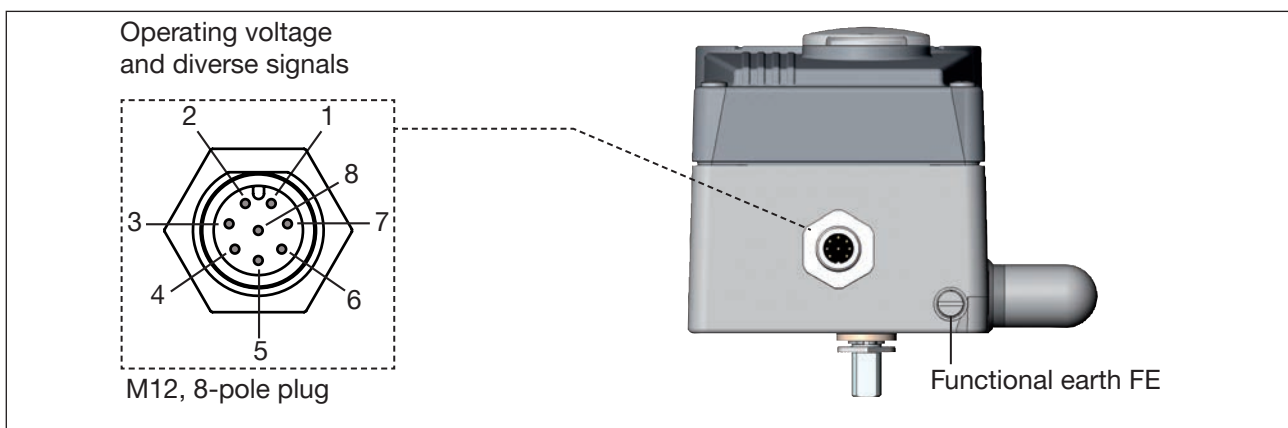



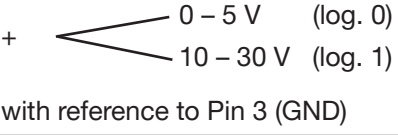

Figure 32: Designation of the circular plug-in connector and contacts



13.2.2 Pin assignment for input signals from the control centre (e.g. PLC) - M12, 8-pole plug

Pin	Wire color*	Configuration	On the device side	External circuit / Signal level
1	white	Set-point value + (0/4 – 20 mA)	1 	+ (0/4 – 20 mA)
2	brown	Set-point value GND	2 	GND set-point value
5	grey	Binary input	5 	+ 

* The indicated wire colors refer to the connection cable, part no. 919061, available as an accessory.

Table 23: Pin assignment; input signals of the control centre - M12, 8-pole plug

13.2.3 Pin assignment for output signals to the control centre (e.g. PLC) - M12, 8-pole plug (required for analogue output option only)

Pin	Wire color*	Configuration	On the device side	External circuit / Signal level
8	red	Analogue feedback +	8 	+ (0/4 – 20 mA)
7	blue	Analogue feedback GND	7 	GND (identical with the GND supply voltage)

* The indicated wire colors refer to the connection cable, part no. 919061, available as an accessory.

Table 24: Pin assignment; output signals to the control centre - M12, 8-pole plug

13.2.4 Pin assignment for operating voltage - M12, 8-pole circular plug-in connector

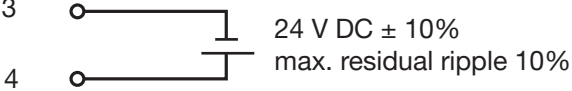
Pin	Wire color*	Configuration	External circuit / Signal level
3	green	GND	
4	yellow	+24 V	

* The indicated wire colors refer to the connection cable, part no. 919061, available as an accessory.

Table 25: Pin assignment; operating voltage - M12, 8-pole circular plug-in connector

13.3 Electrical connection with cable gland

13.3.1 Designation of the screw-type terminals

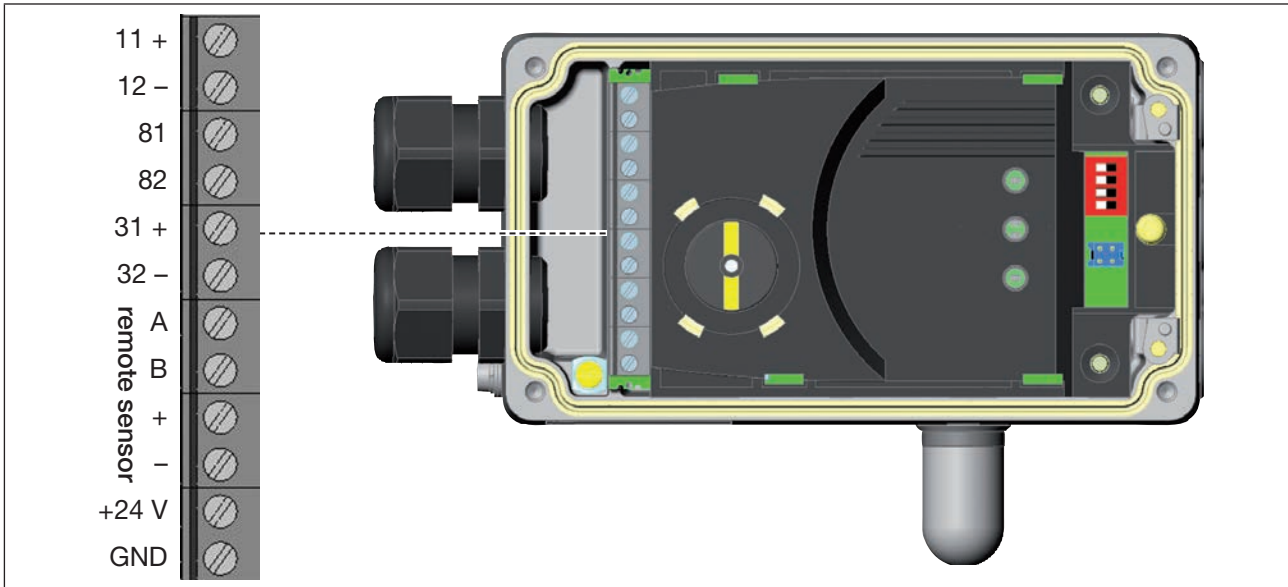

Figure 33: Designation of the screw-type terminals

13.3.2 Connection of the screw-type terminals

- Unscrew the 4 screws on the housing cover and remove the cover.
The screw-type terminals are now accessible.
- Connect terminals according to the configuration.

13.3.3 Terminal assignment for input signals from the control centre (e.g. PLC)

Terminal	Configuration	On the device side	External circuit / Signal level
11 +	Set-point value +	11 + ○ ———	+ (0/4 – 20 mA)
12 –	Set-point value GND	12 – ○ ———	GND set-point value
81 +	Binary input +	81 + ○ ———	+ $\begin{cases} 0 - 5 \text{ V} & (\text{log. } 0) \\ 10 - 30 \text{ V} & (\text{log. } 1) \end{cases}$
82 –	Binary input –	82 – ○ ———	GND (identical with the GND supply voltage)

Table 26: Terminal assignment; input signals of the control centre

13.3.4 Terminal assignment for output signals to the control centre (e.g. PLC) (required for analogue output option only)



Terminal	Configuration	On the device side	External circuit / Signal level
31 +	Analogue feedback +	31 + 	+ (0/4 – 20 mA)
32 –	Analogue feedback GND	32 – 	GND (identical with the GND supply voltage)

Table 27: Terminal assignment; output signals to the control centre

13.3.5 Terminal assignment for operating voltage

Terminal	Configuration	External circuit / Signal level
+24 V	Operating voltage +	 +24 V 24 V DC ± 10% max. residual ripple 10%
GND	Operating voltage GND	

Table 28: Terminal assignment; operating voltage

13.3.6 Terminal assignment for external position sensor (for remote model only)





Terminal	Configuration	On the device side	External circuit / Signal level
S +	Supply sensor +	S + 	 Remote-Sensor Type 8798 ¹¹⁾
S -	Supply sensor -	S - 	
A	Serial interface, A cable	A 	
B	Serial interface, B-cable	B 	
11) Assignment of the wire color see "Table 30"			

Table 29: Terminal assignment; external position sensor

Positioner Terminal	Wire color Remote-Sensor with cable type 1	Wire color Remote-Sensor with cable type 2
S +	brown	brown
S -	white	black
A	green	red
B	yellow	orange

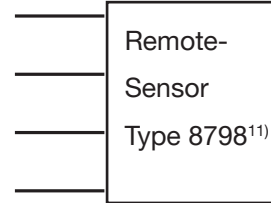
Table 30: Assignment of the wire color (Remote-Sensor)

14 START-UP

14.1 Safety instructions



WARNING!

Risk of injury from improper operation.

Improper operation may result in injuries as well as damage to the device and the area around it.

- ▶ Before start-up, ensure that the operating personnel are familiar with and completely understand the contents of the operating instructions.
- ▶ Observe the safety instructions and intended use.
- ▶ Only adequately trained personnel may operate the equipment/the device.

14.2 Specifying the standard settings

The basic settings of the positioner are implemented at the factory.



To adjust the positioner to local conditions, the *X.TUNE* function must be run following installation.

14.2.1 Running the automatic adjustment *X.TUNE*:



WARNING!

Danger due to the valve position changing when the *X.TUNE* function is running.

When the *X.TUNE* is running under operating pressure, there is an acute risk of injury.

- ▶ Never run *X.TUNE* while a process is running.
- ▶ Take appropriate measures to prevent the equipment from being accidentally actuated.

NOTE!

Avoid maladjustment of the controller due to an incorrect supply pressure or applied operating medium pressure.

- ▶ Run *X.TUNE* **whenever** the supply pressure (= pneumatic auxiliary energy) is available during subsequent operation.
- Run the *X.TUNE* function preferably **without** operating medium pressure to exclude interference caused by flow forces.



To run *X.TUNE*, the positioner must be in the AUTOMATIC operating status (DIP switch 4 = OFF).

→ Start *X.TUNE* by pressing key 1 for 5 sec ¹²⁾.

While *X.TUNE* is running, LED 1 flashes very quickly (green).

When the automatic adjustment has completed, LED 1 flashes slowly (green) ¹³⁾.

The changes are automatically transferred to the memory (EEPROM) only when the *X.TUNE* function is successful.



If LED 3 (red) is lit after the *X.TUNE* function started, the *X.TUNE* function was ended due to a fault.

- Check possible faults
(see [“Table 13: Error messages while the X.TUNE function is running”](#)).
- Then repeat the *X.TUNE* function.

12) *The X.TUNE can also be started via communications software.*

13) *If a fault occurs, LED 3 is lit red.*

15 AS-INTERFACE

15.1 AS-Interface connection

AS-Interface (Actuator Sensor Interface) is a field bus system which is used primarily for networking binary sensors and actuators (slaves) with a higher-level control (master).

Bus line

Unshielded two-wire line (AS-Interface line as AS-Interface cable harness) along which both information (data) and energy (supply voltage for the actuators and sensors) are transmitted.

Network topology

Freely selectable within wide limits, i.e. star, tree and line networks are possible. Further details describe the AS-Interface specification (A/B slave model conforms to the version 3.0 specification).

15.2 Technical data for AS-Interface PCBs

	Version S-7.3.4 profile	Version S-7.A.5 profile
Supply	via AS-Interface	via AS-Interface
Outputs	16 bit set-point value	16 bit set-point value
Inputs	-	16 bit feedback
Certification	Certificate no. 87301 according to version 3.0	Certificate no. 95401 according to version 3.0

Table 31: Technical data

15.3 Programming data

	Version S-7.3.4 profile	Version S-7.A.5 profile
I/O configuration	7 hex	7 hex
ID code	3 hex (analog profile)	A hex
Extended ID code 1	F hex (Default value, can be changed by the user)	7 hex
Extended ID code 2	4 hex	5 hex
Profile	S-7.3.4	S-7.A.5

Table 32: Programming data

Bit configuration

1. Output set-point value (Value range 0 – 10,000, is equivalent to 0 – 100 %)
2. Input feedback¹⁴⁾ (Value range 0 – 10,000 (16 Bit, signed integer), is equivalent to 0 – 100 %)
 - Values below 0 (0.0 %) and above 10,000 (100.0 %) are possible due to mechanical tolerances.
 - Example: Position -1.0 % corresponds to -100 = 0xFF9C

Byte 2								Byte 1							
D15	D14	D13	D12	D11	D10	D9	D8	D7	D6	D5	D4	D3	D2	D1	D0

Parameter bit	P3	P2	P1	P0
Output	not used	not used	not used	not used

Table 33: Bit configuration

15.4 Communication sequence for the version S-7.A.5 profile

1. Following start-up, the AS interface master (from master class 4) automatically replaces the ID object with the S-7.A.5 slave

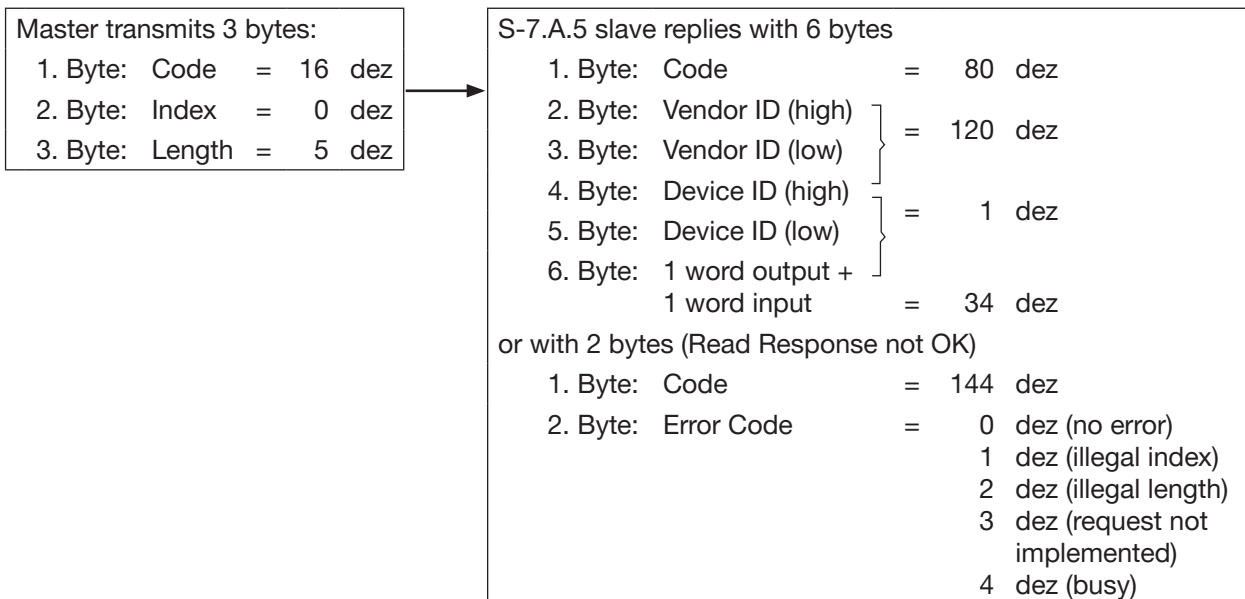

2. Then the following cyclical commands can be used:

Code = 0 (get cyclic data from Slave)
→ for feedback 0 – 100 %

Code = 1 (put cyclic data to slave)
→ for set-point value 0 – 100 %

¹⁴⁾ Only for version with S-7.A.5 profile

15.5 LED status display (bus)

The LED bus status display indicates the status of the AS-Interface (LED green and red).

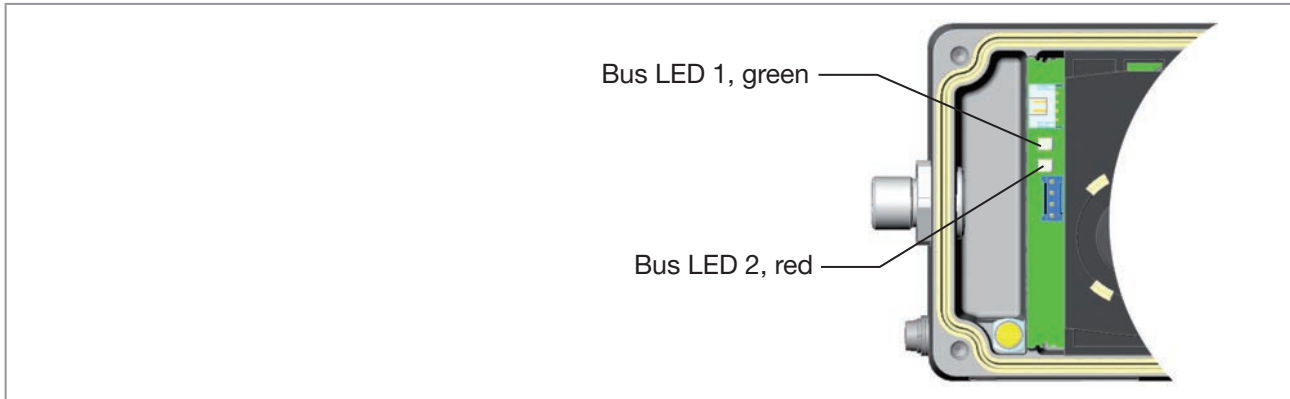

Table 34: LED status display (Bus)

Bus LED 1 (green)	Bus LED 2 (red)	
off	off	POWER OFF
off	on	No data traffic (expired Watch Dog at slave address does not equal 0)
on	off	OK
flashing	on	Slave address equals 0
off	flashing	Electronic error or external reset
flashing	flashing	Timeout bus communication after 100 ms (periphery error)

Table 35: LED Status display

15.6 Electrical connection AS-Interface

15.6.1 Safety instructions

DANGER!

Risk of electric shock.

- ▶ Before working on equipment or device, switch off the power supply and secure to prevent reactivation.
- ▶ Observe applicable accident prevention and safety regulations for electrical equipment.

WARNING!

Risk of injury from improper installation.

- ▶ Installation may be carried out by authorised technicians only and with the appropriate tools.

Risk of injury from unintentional activation of the system and an uncontrolled restart.

- ▶ Secure system from unintentional activation.
- ▶ Following installation, ensure a controlled restart.

15.6.2 Connection with M12 circular plug-in connector, 4-pole, male

 It is not necessary to open the housing for the multi-pole connections.

Bus connection without external / with external supply voltage

Pin	Designation	Configuration
1	Bus +	AS-Interface bus line +
2	NC or GND (optional)	not used or external supply voltage - (optional)
3	Bus -	AS-Interface bus line -
4	NC or 24 V + (optional)	not used or external supply voltage + (optional)

Table 36: Pin assignment of circular plug-in connector for AS-Interface

Views of plug: From the front onto the pins, the soldered connections are behind

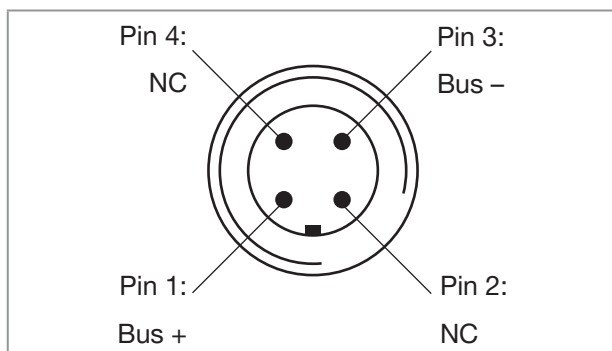

Table 37: Bus connection without external supply voltage

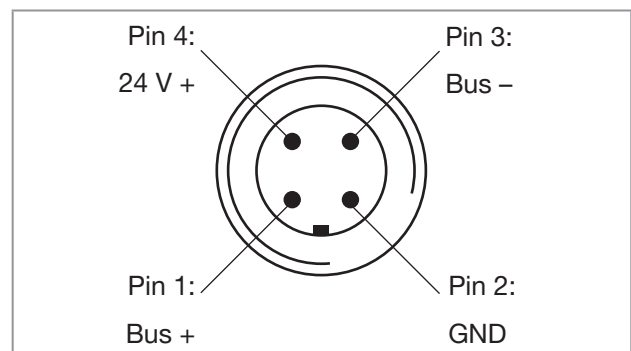

Table 38: Bus connection with external supply voltage (optional)

16 SERVICE

If the positioner type 8791 is operated according to the instructions in this manual, it is maintenance-free.

17 ACCESSORIES

CAUTION!

Risk of injury and/or damage by the use of incorrect parts.

Incorrect accessories and unsuitable replacement parts may cause injuries and damage the device and the surrounding area.

- ▶ Use only original accessories and original replacement parts from Bürkert.

 The order numbers of the attachment kits for linear or rotary actuators as well as for the matching cable plugs of the multi-pole version of the positioner can be found in the data sheet for type 8791.

Designation	Order no.
M12 connection cable, 8-pole	919061
USB adapter with interface driver for connection to a PC in conjunction with an extension cable	227093
Communicator / Pactware and DTM	Information at www.burkert.com

Table 39: Accessories

17.1 Communications software

The PC operating program “Communicator” is designed for communication with the devices from the Bürkert positioner family (basic models without display). Devices constructed since August 2014 support the full range of functions. If you have any questions regarding compatibility, please contact the Bürkert Sales Center.

 A detailed description and precise schedule of the procedure for the installation and operation of the software can be found in the associated documentation.

17.1.1 USB interface

The PC requires an USB interface for communication with the positioner as well as an additional adapter with interface driver (see “Table 39: Accessories”).

The data transfer must be according to HART specification.

17.1.2 Download

Download the software: www.burkert.com

18 PACKAGING AND TRANSPORT

NOTE!

Transport damages.

Inadequately protected equipment may be damaged during transport.

- ▶ During transportation protect the device against moisture and dirt in shock-resistant packaging.
- ▶ Follow the allowable storage temperature.

19 STORAGE

NOTE!

Incorrect storage may damage the device.

- ▶ Store the device in a dry and dust-free location.
- ▶ Storage temperature -20 – +65 °C.

20 DISPOSAL

→ Dispose of the device and packaging in an environmentally friendly manner.

NOTE!

Damage to the environment caused by device components contaminated with media.

- ▶ Observe applicable disposal regulations and environmental regulations.



Observe national waste disposal regulations.

