

Type ME43

Fieldbus gateway bus to Industrial Ethernet for
PROFIBUS DPV1, PROFINET, PROFINET S2, EtherNet/IP,
EtherCAT, Modbus TCP, CC-Link IE field basic



We reserve the right to make technical changes without notice.
Technische Änderungen vorbehalten.
Sous réserve de modifications techniques.

© Bürkert Werke GmbH & Co. KG, 2017 – 2024

Operating Instructions 2412/07_EUen_00810575 / Original DE

CONTENTS

1	OPERATING INSTRUCTIONS	6
1.1	Symbols.....	6
1.2	Definition of terms.....	7
2	INTENDED USE	7
3	BASIC SAFETY INSTRUCTIONS	8
4	GENERAL NOTES.....	9
4.1	Contact addresses.....	9
4.2	Warranty	9
4.3	Information on the Internet.....	9
5	PRODUCT DESCRIPTION.....	10
6	TECHNICAL DATA	11
6.1	Standards and directives.....	11
6.2	Operating conditions	11
6.3	Mechanical data.....	11
6.4	Electrical data	11
6.5	Industrial Ethernet.....	12
6.5.1	PROFINET / PROFINET S2.....	12
6.5.2	EtherNet/IP.....	12
6.5.3	Modbus TCP.....	12
6.5.4	PROFIBUS DPV1	13
6.5.5	EtherCAT.....	13
6.5.6	CC-Link.....	13
6.5.7	OPC UA	14
6.6	Type label, device labelling.....	14
7	INSTALLATION.....	15
7.1	Mounting the device onto the standard rail.....	15
7.2	Electrically connecting the device	16
7.3	Establish connection to the fieldbus.....	16

7.3.1	Industrial Ethernet.....	16
7.3.2	PROFIBUS version	17
7.3.3	CC-Link version	17
8	MICRO SD CARD	18
8.1	Configuration provider	19
9	COMMISSIONING WITH FIELDBUS GATEWAY	20
9.1	Operating elements.....	20
9.2	Operation with the display.....	20
9.3	Protocol settings for connecting the device to the PLC network.....	21
9.3.1	Selecting the protocol.....	21
9.3.2	Enter address.....	21
9.4	Settings on the display	22
10	START-UP WITH BÜRKERT COMMUNICATOR	23
10.1	User interface.....	23
10.2	Connecting the device to the Bürkert Communicator	24
10.3	Protocol settings for connecting the device to the PLC network.....	24
10.3.1	Selecting the protocol.....	24
10.3.2	Enter PROFIBUS address.....	24
10.3.3	Entering CC-Link address	24
10.3.4	Entering the EtherCAT address (Station Alias).....	25
10.3.5	Enter parameters for EthernetNET/IP, PROFINET, PROFINET S2, Modbus TCP, Ethercat, CC-Link IE filed basic	25
10.4	Configuring the fieldbus gateway	26
10.4.1	Downloading a gateway configuration	26
10.4.2	Editing a gateway configuration	26
10.4.3	Creating a new gateway configuration	26
10.5	büS network	38
10.5.1	Set up büS network.....	38
10.5.2	Configuring the büS network.....	40
11	START-UP USING A WEB SERVER	41
11.1	Function of the web server	41
11.2	Deactivate to the web server via Bürkert Communicator	41
11.3	Establishing a connection to the web server.....	41

11.4	Logging onto the web server.....	42
11.5	Passwords.....	43
11.5.1	Change password.....	43
11.5.2	Factory reset of password	43
11.6	Configuring the device.....	43
12	OPC UA.....	44
12.1	General description.....	44
12.2	Establish connection with OPC UA.....	44
12.2.1	Settings on the device	44
12.2.2	Settings for the OPC UA client	45
12.3	Server certificate	45
13	DISPLAY ELEMENTS	47
13.1	LEDs for indicating the network connection to the Industrial Ethernet	47
13.2	LED for displaying the device status	48
13.3	Displays.....	49
14	BÜRKERT COMMUNICATOR MENUS	50
14.1	f(x) configuration	50
14.2	“Web server” and “OPC UA”	50
14.3	Configuration area “PROFINET”, “PROFINET S2”, “EtherNet/IP”, “EtherCAT” “Modbus TCP” and “CC-Link IE field basic”	51
14.4	“EtherCAT” configuration area	52
14.5	Configuration section “General settings”	53
15	REPLACING THE DEVICE.....	56
16	TROUBLESHOOTING.....	58
16.1	Description of the error code	59
16.2	Status indicators and measures.....	63
17	ACCESSORIES	64
18	DISASSEMBLY	65
19	TRANSPORTATION, STORAGE, DISPOSAL.....	66

1 OPERATING INSTRUCTIONS

The operating instructions describe the entire life cycle of the device. Keep these instructions ready to hand at the operation site.

Important safety information.

- ▶ Read these instructions carefully.
- ▶ Observe in particular the safety instructions, intended use and operating conditions.
- ▶ Persons who work on the device must read and understand these instructions.

1.1 Symbols



DANGER

Warns of an immediate danger.

- ▶ Failure to observe these instructions will result in death or serious injuries.



WARNING

Warns of a potentially hazardous situation.

- ▶ Failure to observe these instructions may result in serious injuries or death.



CAUTION

Warns of a potential danger.

- ▶ Failure to observe may result in moderate or minor injuries.

NOTE

Warns of damage.

- ▶ Failure to observe these instructions may result in damage to the device or the system.



Indicates important additional information, tips and recommendations.



Refers to information in these operating instructions or in other documentation.



Designates instructions to avoid danger.



Designates a procedure which you must carry out.



Designates a result.



Symbol for software interface texts.

1.2 Definition of terms

Definition of the terms used in these instructions.

- **Device:** the term “Device” stands for the following device types: ME43
- **Ex area:** the term “Ex area” stands for potentially explosive atmosphere
- **Ex approval:** the term “Ex approval” stands for approval in the potentially explosive atmosphere
- **büS (Bürkert system bus):** the term “büS” stands for the communication bus developed by Bürkert, based on the CANopen protocol.

2 INTENDED USE

Improper use of the device may be dangerous to people, nearby equipment and the environment.

The fieldbus gateway Type ME43 is used as a fieldbus converter for the process values between büS participants and an industrial Ethernet PLC.

The Type ME43 supports the fieldbus protocols PROFIBUS DPV1, EtherCAT, PROFINET, PROFINET S2, EtherNet/IP, Modbus TCP, CC-Link as well as DeviceNet and CANopen.

- ▶ To use the device, observe the permitted data, operating conditions and application conditions. These specifications can be found in the contract documents, the operating instructions and on the type label.
- ▶ In the potentially explosive atmosphere, only use devices that are approved for this purpose. These devices are identified by a separate Ex type label. Before use, note the information on the separate Ex type label and the Ex additional information or the separate Ex operating Instructions.

The device

- ▶ must not be used outdoors.
- ▶ must not be opened.
- ▶ must only be used in conjunction with third-party devices and components recommended and authorised by Bürkert.
- ▶ must only be used when in perfect condition; always ensure proper storage, transportation, installation and operation.
- ▶ only as intended.

3 BASIC SAFETY INSTRUCTIONS

These safety instructions do not take into account any unforeseen circumstances and events which occur during installation, operation and maintenance. The operator is responsible for observing the location-specific safety regulations, also with reference to personnel.



General hazardous situations.

To prevent injuries, observe the following:

- ▶ Use the device only when it is in perfect condition and in accordance with the operating instructions.
- ▶ Do not make any changes to the device and do not subject it to mechanical stress.
- ▶ Secure device or system to prevent unintentional activation.
- ▶ Only trained technicians may perform installation and maintenance work.
- ▶ Install the device according to the regulations applicable in the respective country.
- ▶ After an interruption in the power supply, ensure that the process is restarted in a controlled manner.
- ▶ Observe the general rules of technology.

NOTE

Electrostatically sensitive components and assemblies.

The device contains electronic components that are susceptible to the effects of electrostatic discharging (ESD). Components that come into contact with electrostatically charged persons or objects are at risk. In the worst case scenario, these components will be destroyed immediately or fail after start-up.

- ▶ Meet the requirements specified by EN 61340-5-1 to minimise or avoid the possibility of damage caused by a sudden electrostatic discharge.
- ▶ Do not touch electronic components when the supply voltage is connected.

4 GENERAL NOTES

4.1 Contact addresses

Germany

Bürkert Fluid Control Systems
Sales Centre
Christian-Bürkert-Str. 13-17
D-74653 Ingelfingen
Tel. + 49 (0) 7940 - 10-91 111
Fax + 49 (0) 7940 - 10-91 448
E-mail: info@burkert.com

International

The contact addresses can be found online at:

www.burkert.com

4.2 Warranty

A precondition for the warranty is that the device is used as intended in consideration of the specified operating conditions.

4.3 Information on the Internet

Operating instructions and data sheets for the Bürkert products can be found on the Internet at:

www.burkert.com

5 PRODUCT DESCRIPTION

The fieldbus gateway type ME43 is used as a fieldbus converter between büS and Industrial Ethernet.

Application range:

Exchange process values between participants of fieldbus 1 and fieldbus 2.

Device type	Fieldbus 1	Fieldbus 2
ME43	büS	PROFINET
ME43	büS	PROFINET S2
ME43	büS	EtherNet/IP
ME43	büS	Modbus TCP
ME43	büS	PROFIBUS DPV1
ME43	büS	CC-LINK IE field basic
ME43	büS	EtherCAT

Table 1: Application area Type ME43



The Bürkert Communicator software is required to configure the fieldbus gateway. The Bürkert Communicator software can be downloaded free of charge from the Bürkert website. In addition to the software, the USB-büS interface set 1 – which is available as an accessory – is required. See chapter [“17 Accessories”](#).

6 TECHNICAL DATA

6.1 Standards and directives

The device complies with the relevant EU harmonisation legislation. In addition, the device also complies with the requirements of the laws of the United Kingdom.

The harmonised standards that have been applied for the conformity assessment procedure are listed in the current version of the EU Declaration of Conformity/UK Declaration of Conformity.

6.2 Operating conditions

NOTE

Malfunction due to heat and heavy frost.

- ▶ Do not use the device outside the specified ambient temperature.

Ambient temperature	-20...+60 °C
Altitude	Up to 2000 m above sea level

6.3 Mechanical data

Dimensions	See data sheet for type ME43
Housing material	Polycarbonate

6.4 Electrical data

Supply voltage:	24 V $\pm 10\%$ – residual ripple 10 %
Power consumption:	< 2 W
Degree of protection:	IP 20 to EN 60529 / IEC 60529 (only with correctly connected cables or plugs and sockets) verified by Bürkert, not evaluated by UL
Protection class:	III according to DIN EN 61140 (VDE 0140)
Interfaces	1 spring-loaded terminal, 5-pin for supply voltage and bÜS connection
PROFIBUS version :	1 push-in connector D-Sub, 9-pin
CC-LINK variant:	1 push-in connector, D-Sub, 9-pin
Industrial Ethernet version:	2 sockets for RJ45 push-in connector
UL devices:	Limited Energy Circuit (LEC) according to UL/IEC 61010-1
	Limited Power Source (LPS) according to UL/IEC 60950
	SELV / PELV with UL Recognized Overcurrent Protection, design according to UL / IEC 61010-1 Table 18
	NEC Class 2 power source

6.5 Industrial Ethernet

6.5.1 PROFINET / PROFINET S2

Topology recognition	LLDP, SNMP V1, MIB2, Physical Device
Minimum cycle time	10 ms
IRT	not supported
MRP media redundancy	MRP client is supported
Other supported functions	DCP, VLAN Priority Tagging, Shared Device
Transmission speed	100 MBit/s
Data transport layer	Ethernet II, IEEE 802.3
PROFINET IO specification	V2.42
(AR) Application Relations	PROFINET: The device can simultaneously process up to 2 IO-ARs, 1 Supervisor AR and 1 Supervisor-DA AR. PROFINET S2: The device can simultaneously establish one connection to the primary and one connection to the backup

6.5.2 EtherNet/IP

Pre-defined standard objects	Identity Object (0x01) Message Router Object (0x02) Assembly Object (0x04) Connection Manager (0x06) DLR Object (0x47) QoS Object (0x48) TCP/IP Interface Object (0xF5) Ethernet Link Object (0xF6)
DHCP	supported
BOOTP	supported
Transmission speed	10 and 100 MBit/s
Duplex modes	Half duplex, full duplex, auto-negotiation
MDI modes	MDI, MDI-X, Auto-MDIX
Data transport layer	Ethernet II, IEEE 802.3
Address Conflict Detection (ACD)	supported
DLR (ring topology)	supported
Integrated switch	supported
CIP reset service	Identity Object Reset Service types 0 and 1

6.5.3 Modbus TCP

Modbus function codes	1, 2, 3, 4, 6, 15, 16, 23
Operation mode	Message mode: Server
Transmission speed	10 and 100 MBit/s
Data transport layer	Ethernet II, IEEE 802.3

6.5.4 PROFIBUS DPV1

Acyclic communication	DP V1 Class 1 Read / Write DP V1 Class 2 Read / Write / Data Transport
Transmission speed	Fixed values from 9.6 kbit/s to 12 Mbit/s Autodetect mode is supported
Maximum size of the transferred data	Input data: 244 Byte Output data: 244 Byte

6.5.5 EtherCAT

Maximum quantity of cyclical input and output data	512 Bytes
Maximum quantity of cyclical input data	1024 Bytes
Maximum quantity of cyclical output data	1024 Bytes
Acyclic communication (CoE)	SDO SDO Master-Slave
Type	Complex Slave
FMMUs	8
Sync Managers	4
Transmission speed	100 MBit/s
Data transport layer	Ethernet II, IEEE 802.3

6.5.6 CC-Link

Supported protocols	CC-Link-Version 2.0 CC-Link-Version 1.11
---------------------	---

CC-Link version 2.0

Number of stations	Up to 4 occupied stations
Maximum quantity of input data	368 Bytes
Maximum quantity of output data	368 Bytes
Input data	112 Bytes (RY) and 256 Bytes (RWw)
Output data	112 Bytes (RX) and 256 Bytes (RWr)
Extended cycles	1, 2, 4, 8
Transmission speeds	156 kBit/s, 625 kBit/s, 2500 kBit/s, 5 MBit/s, 10 MBit/s

CC-Link version 1.1

Number of stations	Up to 4 occupied stations
Maximum quantity of input data	48 Bytes
Maximum quantity of output data	48 Bytes
Input data	4 Bytes (RY) and 8 Bytes (RWw) per occupied station
Output data	4 Bytes (RX) and 8 Bytes (RWr) per occupied station
Transmission speeds	156 kBit/s, 625 kBit/s, 2500 kBit/s, 5 MBit/s, 10 MBit/s

6.5.7 OPC UA

On delivery, the OPC UA server is not enabled.

The OPC UA server runs in the background with the following protocols:

- PROFINET IO
- EtherNet/IP
- Modbus TCP

The function for enabling or disabling the OPS UA server can be set in Bürkert Communicator:

OPC UA > Parameters > Activate OPC UA

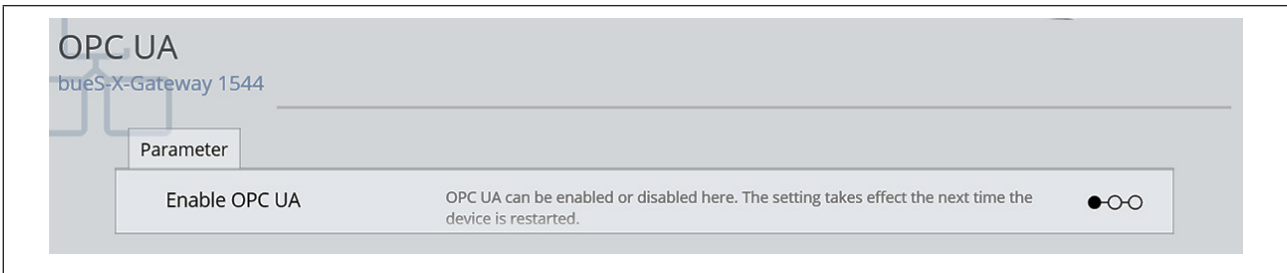

Figure 1: Activate OPC UA

After activating the OPC UA, other server settings will become visible. Note chapter “12” on this topic.

6.6 Type label, device labelling

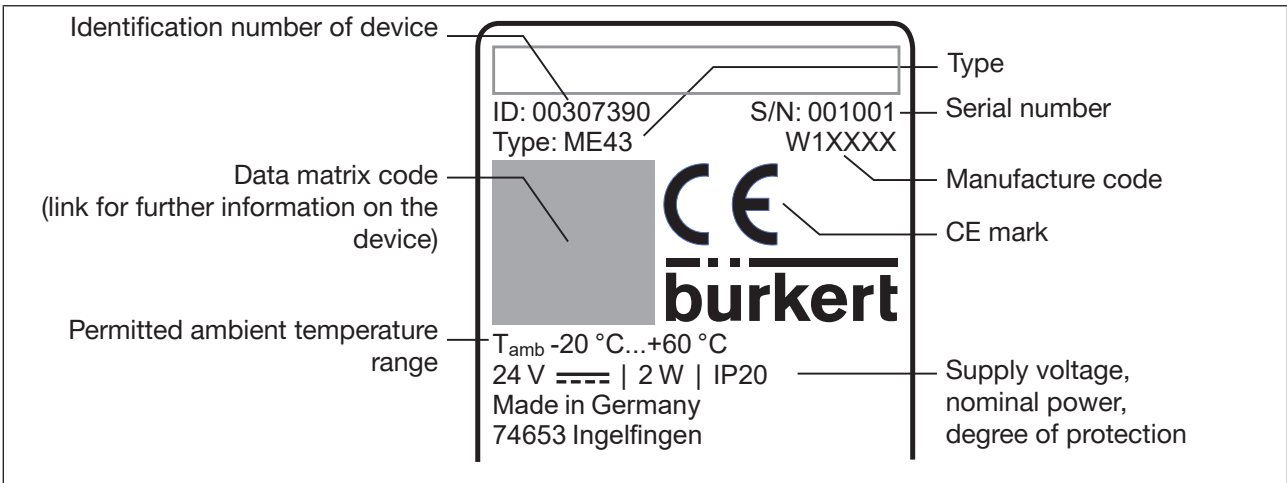

Figure 2: Description of type label and device labelling

7 INSTALLATION

WARNING

Risk of injury due to improper installation.

- ▶ Installation may be carried out by authorised technicians only and with the appropriate tools.
- ▶ Secure the system against unintentional activation.
- ▶ Following installation, ensure a controlled restart.

7.1 Mounting the device onto the standard rail

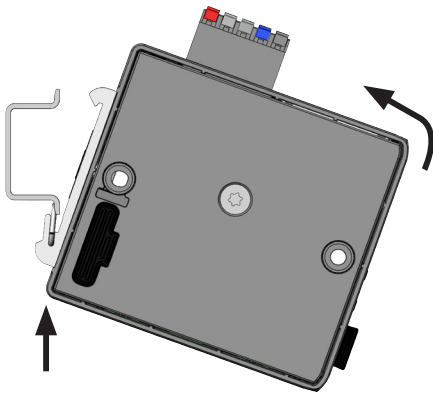

- Hook the device into the lower guide of the standard rail.
- Push the device upward while tilting it to the left and lock it into the upper guide of the standard rail.

For better accessibility to the connections, the unit can be mounted rotated by 180° if necessary.

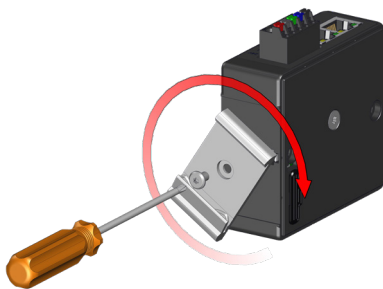

- Loosen the screw.
- Turn the standard rail clip by 180°.
- Tighten locking screw with 2 Nm.

Figure 3: Mounting the device onto the standard rail

7.2 Electrically connecting the device

→ Connect 5-pin spring clamp terminal according to the assignment.

Assignment 5-pin spring clamp terminal		
Plug view	Terminal colour	Description
	Red	Supply voltage 24 V $\overline{\text{---}}$
	White	CAN_H (bùS connection)
	Green	Shielding
	Blue	CAN_L (bùS connection)
	Black	GND

Table 2: Assignment 5-pin spring clamp terminal

7.3 Establish connection to the fieldbus

7.3.1 Industrial Ethernet

→ Plug the Ethernet cables into the sockets of interfaces X1 and X2.
The interfaces X1 and X2 for RJ45 push-in connectors are equivalent.

Assignment interface X1 and X2		
	Pin	Plug configuration
	1	TX+
2	TX-	
3	RX+	
4	Not used	
5	Not used	
6	RX-	
7	Not used	
8	Not used	

Figure 4: Assignment of interfaces X1 and X2; connection to fieldbus

NOTE

To ensure electromagnetic compatibility (EMC).

- ▶ Only use shielded Ethernet cables.
- ▶ To ground the cable shield, connect the Ethernet cables of all participants to the standard rail via the backplane.

→ Connect supply voltage.

7.3.2 PROFIBUS version

Remove D-Sub, 9-pin push-in connector.

D-Sub, 9-pin	Pin	Signal	Function	Connection
	1	Not used		
	2	Not used		
	3	RxD/TxD-P	Data line P (B conductor)	Duty
	4	CNTR-P	Repeater directional control	optional
	5	DGND	Ground for bus terminating resistor	optional
	6	VP	+5 V supply, bus terminating resistor	optional
	7	Not used	Not used	
	8	RxD/TxD-N	Data line N (A line)	Duty
	9	Not used		

Figure 5: PROFIBUS, assignment of D-Sub 9-pin plug connector

7.3.3 CC-Link version

Remove D-Sub, 9-pin push-in connector.

D-Sub, 9-pin	Pin	Signal	Function	Connection
	1	Not used		
	2	Not used		
	3	DA	Data line A	Duty
	4	DG	Data ground	Duty
	5	Not used		
	6	Not used		
	7	Not used		
	8	DB	Data line B	Duty
	9	Not used		

Figure 6: CC-Link, pin assignment D-Sub 9-pin connector

8 MICRO SD CARD

The micro SD card can be used to store device-specific values and user settings and transfer them to another device.



The micro SD card is not suitable for backups. If the micro SD card of the device is re-inserted at a later stage, the data last saved are not restored. The function of the micro SD card is limited to data exchange.

Note!

By resetting the device to the factory settings, the data saved on the SD card are also reset.

A newly created micro SD card is checked for the presence of existing data when the device is re-started. This data will be transferred or overwritten accordingly:

- The micro SD card does not contain any data.
The existing device-specific values are saved to the micro SD card.
- The micro SD card contains data compatible with the device.
The data on the micro SD card are transferred by the device. The existing device-specific values and user settings are overwritten.
- The micro SD card contains data that are not compatible with the device.
The device overwrites the data on the micro SD card with its own device-specific values and user settings.

NOTE

The micro SD card used is a special industrial version that offers additional durability and temperature-resistance.

- ▶ Do not use a standard micro SD card for the device. Only purchase the micro SD card for the device from your Bürkert sales department.

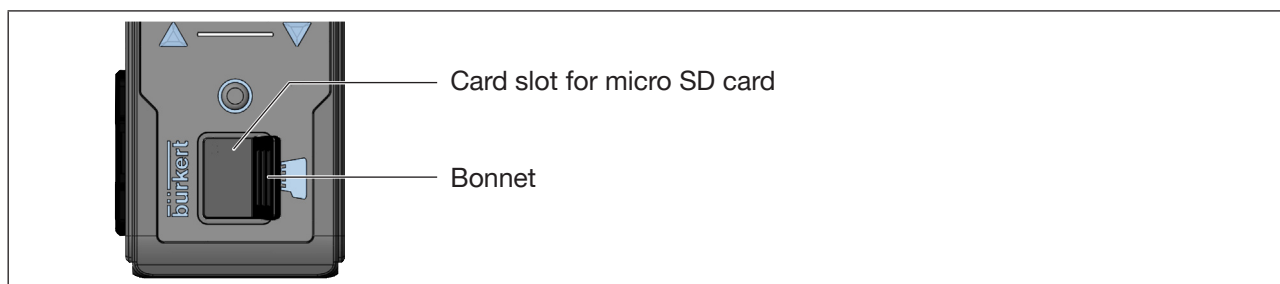

Figure 7: Change micro SD card; ME43 fieldbus gateway

NOTE

Removing the SD card while the power supply is on can lead to data loss and damage to the card.

- ▶ Do not remove the SD card while the device is connected to the supply voltage.



The SD card can be inserted while the device is connected to the supply voltage. A restart is required to ensure that the device detects the SD card.

Removing the micro SD card:

- Pull the bonnet carefully out of the recess.
- Turn the bonnet away from the top left.
- To unlock, press on the edge of the engaged micro SD card.
- Remove the micro SD card.

Insert the micro SD card into the replacement device:

 Observe the direction of insertion when inserting the card.

- Slide the micro SD card into the card slot.
Make sure that the micro SD card locks into position.
- Close card slot with bonnet.

8.1 Configuration provider

Specify whether the device will compile the configuration from other devices in the bÜS network (config clients) and saves it on the SD card.

This function is only possible if an SD card is present in the device.

9 COMMISSIONING WITH FIELDBUS GATEWAY

9.1 Operating elements

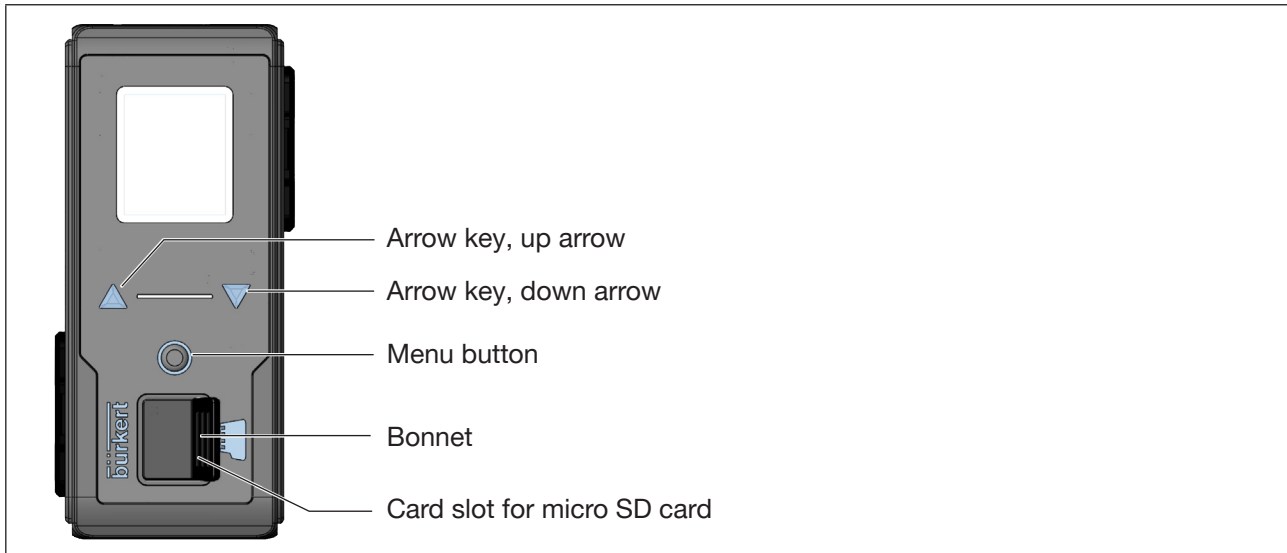

Figure 8: Overview of the operating elements

9.2 Operation with the display

The display is operated with the two arrow keys and the round menu key.

Open the main menu:

→ Press menu button twice.

Returning from a menu:

→ ▲▼ Use the arrow keys **Back** or **Discard** or **Save to select** and confirm with the menu key.

Effect of the selection:

Back Return to the next, higher menu level.

Discard Discards unsaved settings and returns to the next, higher menu level.

Save Save changed settings and return to the next, higher menu level.

Description of buttons:

Element	Description
▼ Down arrow key	Scroll down in the menu
	Reduce numerical values. Press and hold the arrow key to scroll quickly
▲ Up arrow key	Scroll up in the menu
	Raise numerical values. Press and hold the arrow key to scroll quickly
● Menu button	Open main menu (press menu button twice)
	Confirm selection
	Confirm input

Table 3: Description of buttons

9.3 Protocol settings for connecting the device to the PLC network

Selection of the appropriate fieldbus protocol is a requirement for configuration of the device and connection to the network.



If devices feature a PROFIBUS interface, CC-Link interface and PROFINET S2 interface, the fieldbus protocol has been preset at the factory.

9.3.1 Selecting the protocol

→ Press menu button twice.

→ Select **Parameter**.

→ Select **Protocol**.

9.3.2 Enter address

PROFIBUS:

Parameter > **Protocol** > **PROFIBUS**

→ Enter address. Valid addresses: 0...126. If an address outside the valid range has been set, the device will issue an error message.

CC-Link:

Parameter > **Protocol** > **CC-Link**

→ Enter address. Valid addresses: 0...64. If an address outside the valid range has been set, the device will issue an error message.

EtherNet/IP, PROFINET, Modbus TCP, Ethercat, CC-Link IE filed basic:

Parameter > **Protocol** > **EtherNet/IP, Ethercat, CC-Link IE filed basic, PROFINET** or **Modbus TCP**

→ **Select IP settings** and enter IP address.

- **IP mode** can be set for EtherNet/IP only. Setting in the menu **IP settings**
Factory default setting: **Fixed IP address**.
- **DNS compatible name** can only be set with PROFINET
- **Fixed IP address** Factory default setting: 192.168.0.100
- **Network mask** Factory default setting: 255.255.255.0
- **Standard gateway** Factory default setting: 192.168.0.1.

9.4 Settings on the display



The settings on the display can also be made with the Bürkert Communicator software.

Detailed view on the display	Setting
Parameters	Address Set PROFIBUS address ¹⁾
	Address Set CC-Link address ²⁾
	Set IP mode ³⁾ Selection: Fixed IP , BOOTP , DHCP
	IP settings Set IP address ⁴⁾
	Protocol Set fieldbus protocol: ⁵⁾
	BüS Set baud rate
	NodeID Set the Node ID
	Display Set contrast for display
	Display Set brightness for display
	Installation Adjust the installation position of the device
CfgProvid.	Deactivate from configuration provider
	Activate for configuration provider
Diagnostics	Display of errors by error code. Error description see Chapter “ 16.1 Description of the error code ” Error diagnosis also possible from connected devices
Maintenance	Restart Restart device
	ID number Identification number of the device is displayed
	Serial number Serial number of the device is displayed
	SW version Software version is displayed
	HW version Hardware version is displayed
	büS version büS version is displayed
	ICom version IComm version is displayed
DEVReplace can be used in conjunction with the configuration provider	

Table 4: Settings on the display of the ME43 fieldbus gateway

1) Only available with PROFIBUS DPV1

2) Only available with CC-Link

3) Only for EtherNet/IP

4) Only available for PROFINET, EtherNet/IP, PROFINET S2 and Modbus TCP

5) Only available for PROFINET, EtherNet/IP, EtherCAT and Modbus TCP

10 START-UP WITH BÜRKERT COMMUNICATOR

! The Bürkert Communicator software can be downloaded free of charge from the Bürkert website. In addition to the software, the USB-büS-interface, available as an accessory, is required. For devices with EtherNet protocol, a connection via the REST interface is possible without büS interface.

i This chapter describes the basic use of the Bürkert Communicator. Detailed information on how to use the Bürkert Communicator software can be found on the Bürkert website at: www.burkert.com → 8920 → Downloads “Operating instructions”.

10.1 User interface

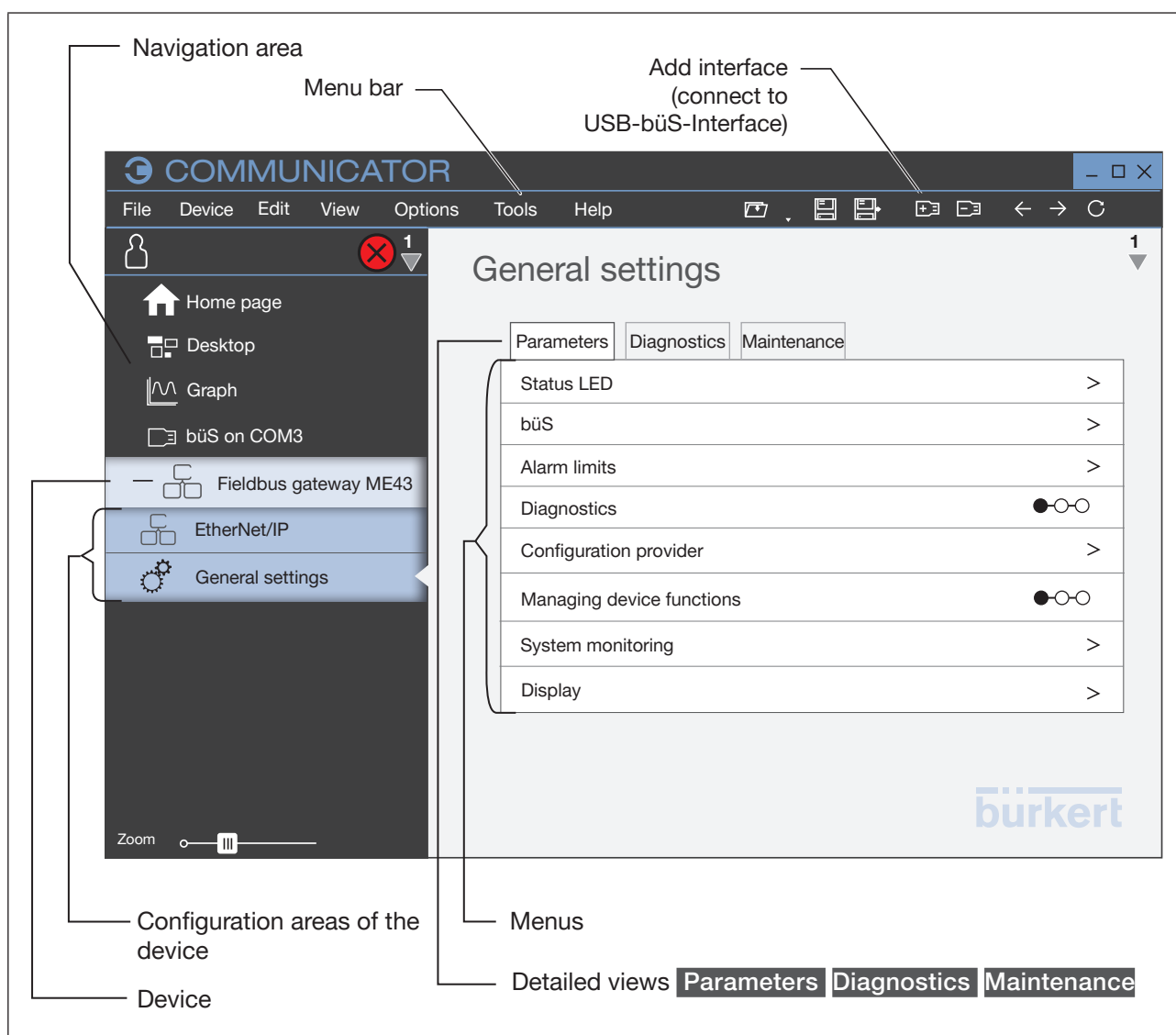

MAN 1000328026 EN Version: | Status: RL (released | freigegeben) | printed: 28.02.2026

Figure 9: Bürkert Communicator user interface

10.2 Connecting the device to the Bürkert Communicator

The Bürkert Communicator can be connected to the device via a bÜS network or with the bÜS stick.

→ Install Bürkert Communicator on the PC.

→ Use the USB-bÜS-interface to establish the connection between the device and the PC.
Not required for the devices in a bÜS network.

→ Start Bürkert Communicator.

→ In the menu bar, click the  icon for **Add interface**.

→ Select **bÜS stick** or **bÜS via network**.
Password required for bÜS via network!

→ **Complete**.

 The device is connected to Bürkert Communicator and is displayed in the navigation area.

10.3 Protocol settings for connecting the device to the PLC network

Selection of the appropriate fieldbus protocol is a requirement for configuration of the device and connection to the network.



If devices feature a PROFIBUS interface, CC-Link interface and PROFINET S2 interface, the fieldbus protocol has been preset at the factory.

10.3.1 Selecting the protocol

(Protocol name) > **Parameters** > **Change protocol** > **Protocol**

→ In the drop-down menu on the right, select the protocol.

10.3.2 Enter PROFIBUS address

Factory default PROFIBUS address: 126

(Protocol name) > **Parameters** > **PROFIBUS DPV1 settings** > **Fixed IP address**

→ Enter address. Valid addresses: 0...126. If an address outside the valid range has been set, the device will issue an error message.

10.3.3 Entering CC-Link address

Factory default CC-Link address: 64

(Protocol name) > **Parameters** > **CC-Link IE field basic settings** > **Fixed IP address**

→ Enter address. Valid addresses: 0...64. If an address outside the valid range has been set, the device will issue an error message.

10.3.4 Entering the EtherCAT address (Station Alias)

(Protocol name) > Parameters > EtherCAT settings > Station Alias or Begin Startup wizard

→ Enter address. Valid addresses: 0...65536. If an address outside the valid range has been set, the device will issue an error message.

10.3.5 Enter parameters for EthernetNET/IP, PROFINET, PROFINET S2, Modbus TCP, Ethercat, CC-Link IE filed basic



With Modbus TCP, it is essential to set the Ethernet parameters.

(Protocol name) > Parameters > (Protocol name) settings > Begin Startup wizard

→ Enter parameters.

Ethernet parameters:

- IP operation mode can only be set with EtherNet/IP, factory setting: Fixed IP address
- DNS compatible name can only be set with PROFINET
- Fixed IP address factory setting: 192.168.0.100
- Network mask factory setting: 255.255.255.0
- Standard gateway factory setting: 192.168.0.1

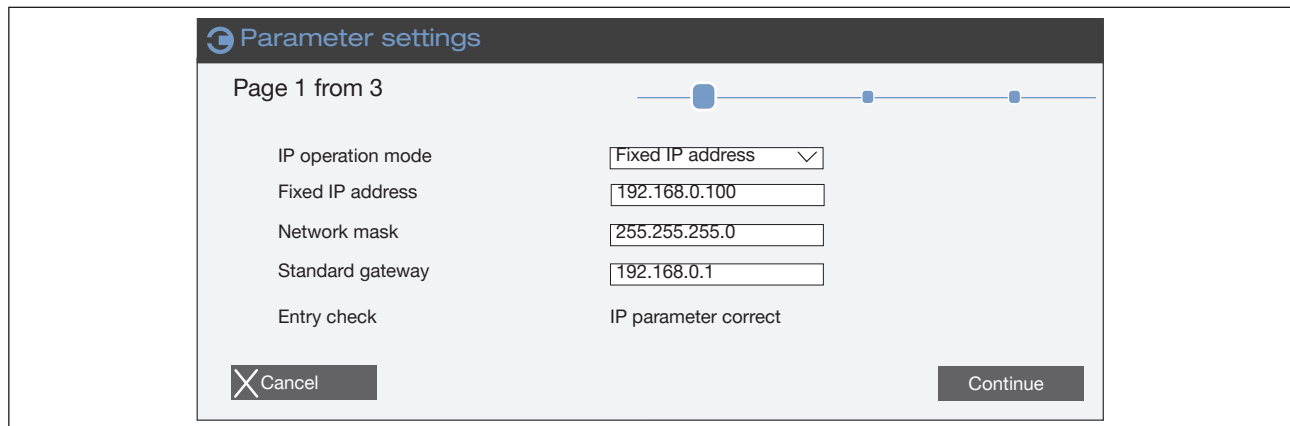

Figure 10: Protocol setting, Startup wizard

The IP parameter settings menu option is used to check the IP parameters entered.

10.4 Configuring the fieldbus gateway

The name of the set protocol (protocol name) appears in the configuration area of Bürkert Communicator.



For configurations with more than 120 values, we recommend using a second gateway. This ensures that the state of function of the gateway is not impaired.

Fieldbus protocol	Input values	Output values	Total number of values	Input Bytes	Output Bytes	Total number of Bytes
PROFIBUS DPV1	128	128	244	244	244	244
PROFINET	128	128	256	512	512	1024
PROFINET S2	128	128	256	512	512	1024
EtherNet/IP	128	128	256	504	504	1008
Modbus TCP	128	128	256	512	512	2048
EtherCAT	128	128	130	512	512	520

The two additional standard values (Namur status and control word) from the gateway itself are included.

Table 5: Maximum number of data values

10.4.1 Downloading a gateway configuration

If a configuration file from an earlier project is present, the device can be configured directly using this.

(Protocol name) > Parameters > Gateway configuration > Download a gateway configuration file
 → **Select Load device configuration to device.**

10.4.2 Editing a gateway configuration

(Protocol name) > Parameters > Gateway configuration > Creating a gateway configuration
 → **Select Edit existing configuration.**

→ Edit configuration. See Chapter 8.4.3 on this topic.

10.4.3 Creating a new gateway configuration

(Protocol name) > Parameters > Gateway configuration > Creating a gateway configuration
 → Select protocol.
 → Select **Start new configuration.**

✓ The Startup wizard will open. The following settings can be made in the Startup wizard.

10.4.4.4 Edit general settings

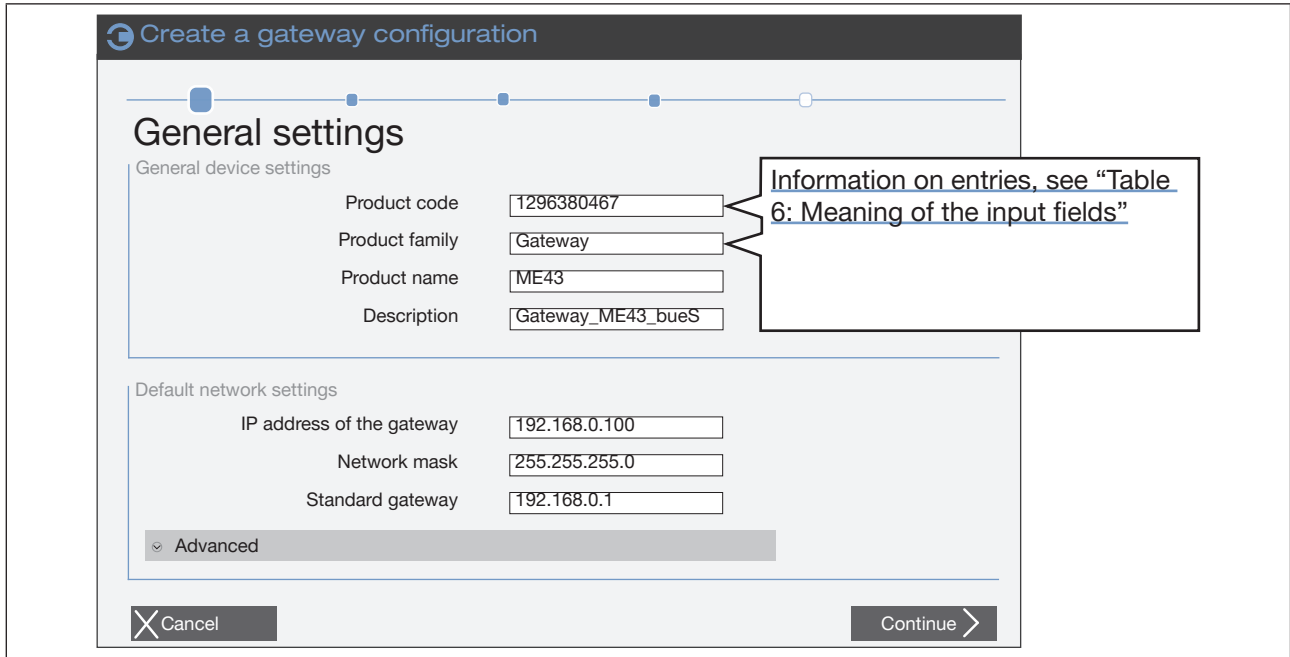

Figure 11: Configuration, general settings

Designation	Meaning
General settings	
Product code	Unique device number. e.g. identification number or custom defined code. Important when using multiple devices: Assign a separate code for each device.
Product family	Used for assigning to a device group in the PLC.
Product name	Name used to display the device on the PLC.
Description	Description of the device

Table 6: Meaning of the input fields

- Adjust general settings for device description file of the target system (PLC) (if required).
- Press **Continue**.

10.4.5.5 Declaring inputs and outputs for the Gateway configuration

1. Selecting the products (devices) as well as the input values and output values

2. Declaring inputs and outputs

Example: selected output to be declared (highlighted in grey)

Overview of the selected inputs and outputs

Display of the selected devices/device groups (to delete, click on the X)

Figure 12: Declaring inputs and outputs

1. Selecting the inputs and outputs:

The inputs and outputs to be declared are specified by selecting products or process values.

- Open the list of products and process values by clicking on **+**.
The process values on the büS network are highlighted.

Adding products:

- Add products by drag-and-drop or double-clicking.

Values for declaring inputs and outputs have been predefined in the **Add device(s)** dialog box.

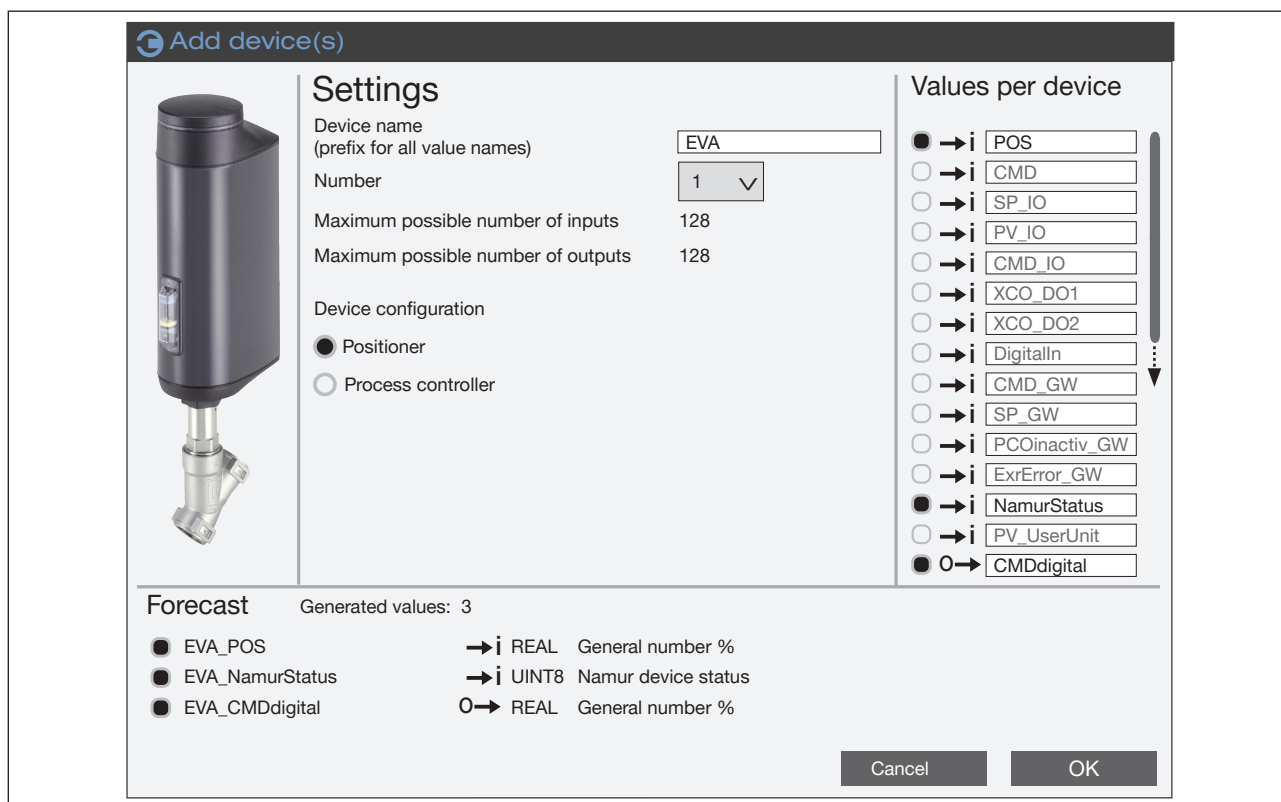

Figure 13: Gateway configuration; add products

Make the following settings in the dialog box:

- Accept or change **Device name** (max. 20 characters)
The name is used for protocol-specific grouping and to improve assignment on the network.
- Select **Number** of devices.
- Select **Device configuration** (if selection option available).
- Accept **Values per device** or select different values.
(To select, click on the square before the value).
! The name of the value can be changed by overwriting it.

Adding process values:

- Add input values and output values via drag-and-drop or double-clicking.

Adding multiple values of the same unit simultaneously:

- Right-click on the unit and then on the **Add multiple** window.

Context-related definition of the values

- Input values
Icon: $\rightarrow i$
Input values are values which come from the bÜS participant and are read by the PLC (bÜS participant \rightarrow Fieldbus gateway \rightarrow PLC)
- Output values
Icon: $o \rightarrow$
Output values are values which are written from the PLC to the bÜS participant/fieldbus gateway.

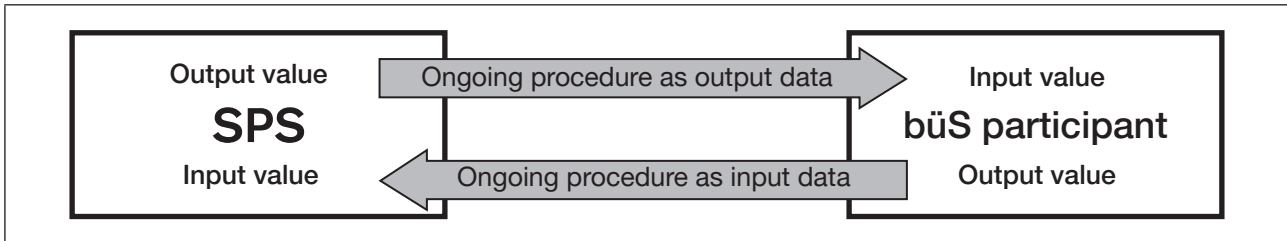

Figure 14: Configuration; type of implementation for process values from the PLC to the bÜS participant

2. Adjusting properties of the values:



The properties for the values only require adjustment if deviations from the standard are requested.

- \rightarrow In the overview click on the input value or output value to be declared.
The selected value is highlighted in grey.
The default values for the declaration are shown at the bottom right.



Meaning of the default values.

The default values are used when the device starts or if the partner device was not found.

For the declaration input or select the following:

- \rightarrow **Accept or adjust Name.** These names appear via the device description file in the target control.
 - \rightarrow Select **Value type.** Specify physical size or device status for the input or output.
 - \rightarrow Select or do not select **Default value.**
The standard value is accepted if no signal arrives from the partner device.
 - \rightarrow Select or do not select **CANopen compatible.**
Is selected when the values are consumed by a CANopen device.
 - \rightarrow Select **Unit conversion.**
Specifies in which physical unit the value is received or sent by the PLC.
- You have selected and declared the inputs and outputs for the gateway configuration.
- \rightarrow Press **Continue** to open the menu for the fieldbus-specific address mapping.

10.4.6.6 Fieldbus-specific address mapping

- Check editable fields and complete if required.
The protocol-specific settings are explained in the following screenshots.
- Press **Continue**.

Address mapping for EtherNet/IP:

The screenshot shows the 'EtherNet/IP settings' screen in the 'Create a gateway configuration' application. It is divided into two main sections: 'EthernetIP Data' and 'Addressing'.

EthernetIP Data:

- Major revision:
- Minor revision:
- Order number:
- EtherNet/IP EDS revision:
- EtherNet/IP product type:
- EtherNet/IP product code:

Addressing:

Automatic EtherNet/IP addressing

Cyclic	Name	Index	Subindex	Assembly	Connection	Class (hex)	Instance (hex)	Attribute (hex)
<input type="checkbox"/>	EVA_POS	0x2540	0x01	0x64	1	0x64	0x01	0x03
<input type="checkbox"/>	EVA_NamurStatus	0x2541	0x01	0x64	1	0x64	0x01	0x03
<input type="checkbox"/>	EVA_CMDdigital	0x2500	0x01	0x65	1	0x65	0x01	0x03
<input type="checkbox"/>	Device status NamurNE107	0x2004	0x01	0x66	2	0x66	0x01	0x03
<input type="checkbox"/>	Control word	0x3C32	0x01	0x67	2	0x67	0x01	0x03

Navigation buttons:

Annotations:

- EtherNet/IP addressing overview (points to the table)
- Automatic EtherNet/IP addressing (points to the 'Start' and 'Reset devices' buttons)
- Start:** Perform automatic EtherNet/IP addressing again
- Reset device:** Resets the values of columns 5 to 9 to 0.
- Fieldbus-specific device data and access data (points to the 'EthernetIP Data' fields)

Figure 15: Gateway configuration; EtherNet/IP address mapping

Address mapping for PROFINET and PROFINET S2:

Header info

Main family: Gateway v Information: Gateway_ME43_bueS
 Device ID: 0x23

Device access point info

Advanced

Module ID: 0x100 Minimum cycle time of the gateway: 4 ms
 Hardware version: A.01.01.00 Software version: 580515
 Maximum input length: 1400 Byte Maximum output length: Byte
 Information: Gateway_ME43_bues Compatible DNS name: MEX3

Addressing

Automatic PROFINET addressing
 Slot and subplot description: These fields become

Start Reset devices

Assign module ID independently

Advanced

Advanced table restore by loading the GSDML file

Cyclic	Name	Index	Subindex	Slot	Subslot	Subslot index	Module ID	GSDML slot description	GSDML subplot description
<input checked="" type="checkbox"/>	EVA_POS	0x2540	0x01	1	1	0	201		
<input checked="" type="checkbox"/>	EVA_NamurStatus	0x2541	0x01	2	1	0	202		
<input checked="" type="checkbox"/>	EVA_CMDdigital	0x2500	0x01	3	1	0	301		
<input checked="" type="checkbox"/>	Device status NamurNE107	0x2004	0x01	4	1	0	203		
<input checked="" type="checkbox"/>	Control word	0x3C32	0x01	5	1	0	302		

Back Cancel Continue

Overview of PROFINET addressing

Automatic PROFINET addressing

Start: Perform automatic PROFINET addressing again

Reset device: Resets the values of columns 5 to 8 back to 0.

! Existing Profinet addressing can be restored by loading the GSDML file.

Fieldbus-specific device data and access data

Figure 16: Gateway configuration; PROFINET address mapping

Address mapping for Modbus TCP:

Modbus TCP settings

Bus ident data
 Device name: MajorMinorRev

Addressing
 Automatic modbus TCP addressing

Coil/register addressing Start address 0 Use Modbus FC03 if possible
 Start address 1

Cyclic	Name	Index	Subindex	Size in Bytes	Address range	Start address	Function code
<input checked="" type="radio"/>	EVA_POS	0x2540	0x01	4	3xxxx	0	Read: FC04
<input checked="" type="radio"/>	EVA_NamurStatus	0x2541	0x01	1	1xxxx	0	Read: FC02
<input checked="" type="radio"/>	EVA_CMDdigital	0x2500	0x01	4	4xxxx	0	Read: FC03, write single: FC06, write...
<input checked="" type="radio"/>	Device status NamurNE107	0x2004	0x01	1	1xxxx	8	Read: FC02
<input checked="" type="radio"/>	Control word	0x3C32	0x01	4	4xxxx	2	Read: FC03, write single: FC06, write...

Overview of Modbus TCP addressing

Automatic modbus TCP addressing

Start: Perform automatic Modbus TCP addressing again

Reset device: Resets the values of columns 5 to 8 back to 0.

Settings:
Coil/register addressing **Register addressing:**
 Coil addressing:

Use Modbus FC03 if possible:

Fieldbus-specific device data and access data

Figure 17: Gateway configuration; Modbus TCP address mapping

Address mapping for EtherCAT:

EtherCAT

EtherCAT data

EtherCAT product code Product code of the EtherCAT device must be a whole number, e. g.: 12345678

EtherCAT revision EtherCAT revision of the device must be an 8-digit hex number beginning with #x ...

Addressing

Automatic EtherCAT addressing

Start **Reset devices**

Cyclic	Name	Index	Subindex
<input type="checkbox"/>	EVA_POS	0x2540	0x01
<input type="checkbox"/>	EVA_NamurStatus	0x2541	0x01
<input type="checkbox"/>	EVA_CMDdigital	0x2500	0x01
<input type="checkbox"/>	Device status NamurNE107	0x2004	0x01
<input type="checkbox"/>	Control word	0x3C32	0x01

< Back **X Cancel** **Continue**

Overview of EtherCAT addressing

Automatic EtherCAT addressing

Start: Perform automatic EtherCAT addressing again

Reset device: Resets the values

Fieldbus-specific device data and access data

Figure 18: Gateway configuration; EtherCAT address mapping

Address Mapping for CC-Link:

gui.gateway.CC-Linkdata

gui.gateway.cclinkstationcycles 2 Station & Extension Cycle: SINGLE ▾

Addressing

Automatic CC-Link addressing

Start Reset devices

Cyclic	Name	Index	Subindex	Start address	
●	EVA_POS	0x2540	0x01	0x000	
●	EVA_NamurStatus	0x2541	0x01	0x00C	
●	EVA_CMDdigital	0x2500	0x01	0x000	
●	Device status NamurNE107	0x2004	0x01	0x00D	
●	Control word	0x3C32	0x01	0x008	

Back Cancel Continue

CC-Link addressing overview

Automatic CC-Link addressing

Start: Perform automatic EtherCAT addressing again

Reset device: Resets the values.

Fieldbus-specific data

Figure 19: Gateway configuration; CC-Link address mapping

10.4.7.7 Saving the gateway configuration

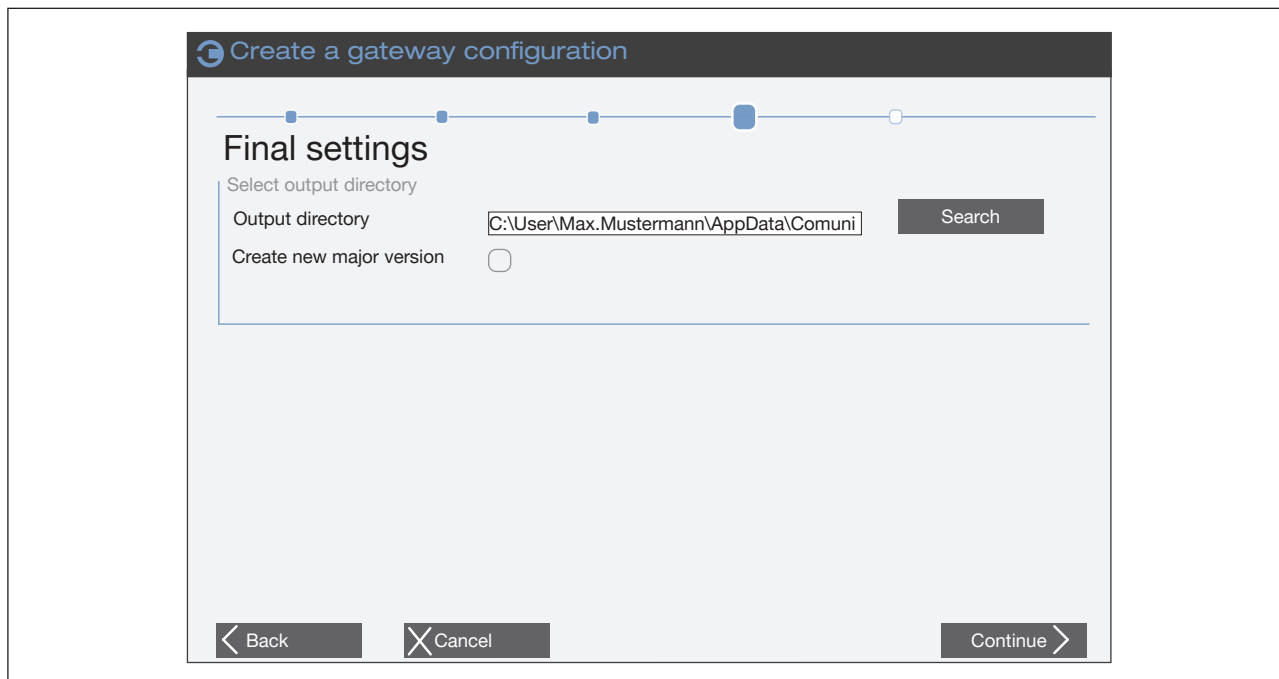

Figure 20: Output directory selection

- Select the output directory in the **Final settings** dialog box.
- Press **Continue**.
The gateway configuration is saved.
The download onto the device runs in the background.
The existing device description file is also located on the specified path in the subfolder.
- Press **Complete**.
- ✔ The configuration of the device is complete. The connection between the PLC and fieldbus gateway is established. To establish a connection, the description files in the control unit are required. The folder in which the description files are located opens automatically.
The following overview shows which files are generated during the gateway configuration.

Gateway configuration files	Storage folder	Description
Protocol-independent files		
Buerkert-Gateway-date-.bgc	No folder	Gateway configuration container.
Buerkert-Gateway-Mapping-date-.xml	BGC	Gateway mapping file. The file is automatically downloaded to the device.
Buerkert-Gateway-date-.eds	EDS	Gateway expansion file. The file is automatically downloaded to the device.

Gateway configuration files	Storage folder	Description
Files for CC-Link		
0x1640_GatewayME43_4_V2.0_E4.cspp	PLC_CCLink	Device description file. Import to the PLC
help_cclink.csv	PLC_CCLink	Overview of the cyclical and acyclic device values.
Files for EtherCAT		
EtherCAT-Buerkert-Gateway-date-.xml	PLC_EtherCAT	Device description file. Optional: Import to the PLC
help_ethercat.csv	PLC_EtherCAT	Overview of the cyclical and acyclic device values.
Files for EtherNet/IP		
EthernetIP-Buerkert-Gateway-date-.eds	PLC_EtherNetIP	Device description file. Import to the PLC.
help_ethernetip.csv/txt	PLC_EtherNetIP	Overview of the cyclical and acyclic device values.
Connection-X-In/Out_Importdata.L5X	PLC_EtherNetIP	Data type for Rockwell users. Used for each assembly.
Files for Modbus TCP		
ModbusTCP-Buerkert-Gateway-date-.txt	PLC_ModbusTCP	Device description file.
help_modbusTcp.csv/txt	PLC_ModbusTCP	Overview of the cyclical and acyclic device values.
Files for PROFIBUS DPV1		
BUER1234.gsd	PLC_Profibus	Device description file. Import to the PLC.
help_profibus.csv/txt	PLC_Profibus	Overview of the cyclical and acyclic device values.
Files for PROFINET / PROFINET S2		
GSDML-V2.42-Buerkert-Gateway-date-.xml	PLC_Profinet	Device description file. Import to the PLC.
GSDML-V2.42-Buerkert-GatewayS2-date-.xml	PLC_Profinet	Device description file. Import to the PLC.
GSDML-0078-0023-icon.bmp	PLC_Profinet	Icon used together with the device description file.
help_profinet.csv/txt	PLC_Profinet	Overview of the cyclical and acyclic device values.

Table 7: Overview of the files which are generated during the gateway configuration

10.5 büS network

10.5.1 Set up büS network

The task of the fieldbus gateway is to convert process values between an Industrial Ethernet PLC and büS participants. To do this, the ME43 fieldbus gateway must be configured and parameterised.

Selection of the büS participants that are to communicate with the PLC via the ME43 fieldbus gateway:

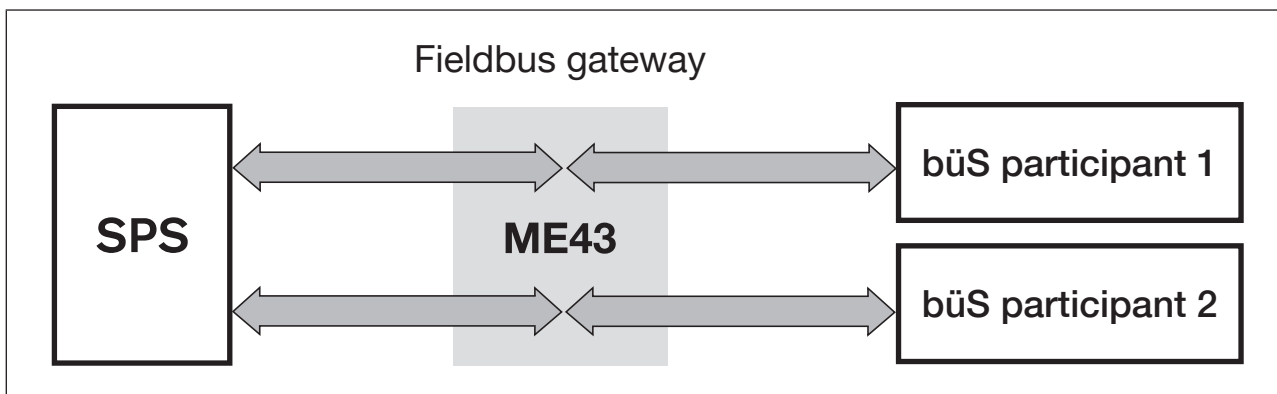

Figure 21: Configuration; selecting the büS participants that are to communicate with the PLC

Selecting which process values are to be converted from “Industrial Ethernet” to “büS”:

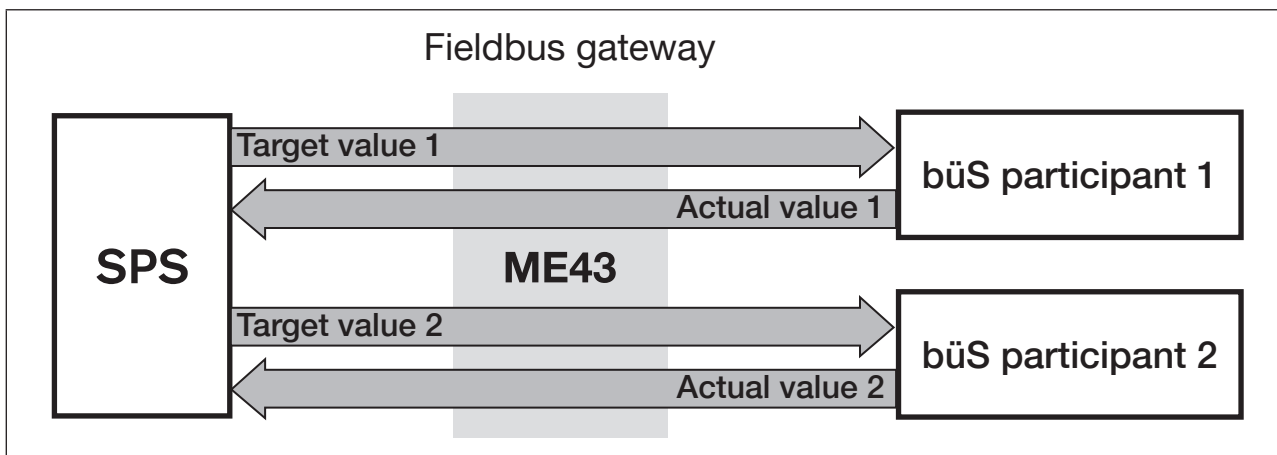

Figure 22: Configuration; selecting the process values to be converted from “Industrial Ethernet” to “büS”

Define the direction for the transmission of the process values (from/to PLC, from/to bÜS participant):

! The direction is assigned in the bÜS fieldbus from the viewpoint of the ME43 fieldbus gateway.
 Example:
 - Set-point values of a bÜS participant are output values of the ME43 fieldbus gateway.
 - Actual values of a bÜS participant are input values of the ME43 fieldbus gateway.

Process output values of the PLC are recorded in the ME43 fieldbus gateway as process input values by Industrial Ethernet. These process input values are converted and output as process output values by bÜS.

Conversely, process output values of the bÜS participant are recorded as bÜS input values. These process input values are converted and output as process output values via Industrial Ethernet.

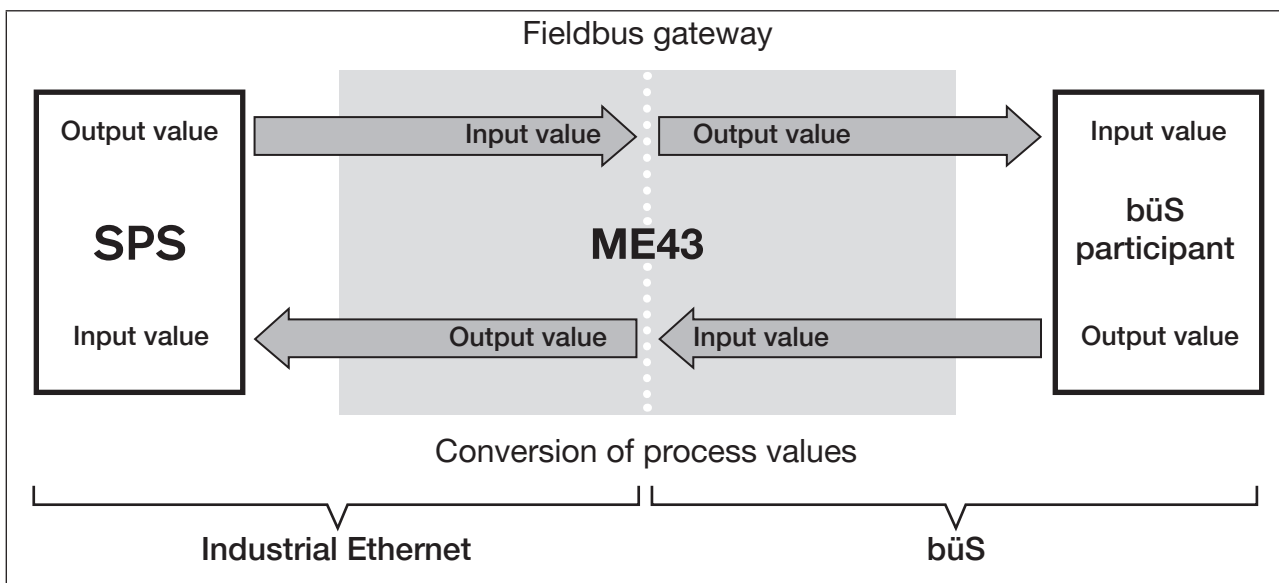

Figure 23: Configuration; principle of direction assignments for process values

Due to the type of implementation, bÜS participants can be addressed directly with their process values and the direction of transmission.

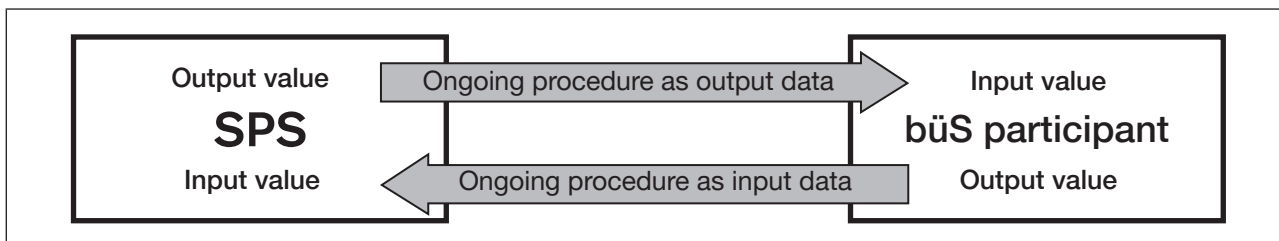

Figure 24: Configuration; type of implementation for process values from the PLC to the bÜS participant

10.5.2 Configuring the büS network

A büS network configuration is required to connect other büS devices successfully to the system and to connect to Type ME43.

→ - Select in the navigation area.

→ Select Detail view **büS map**.

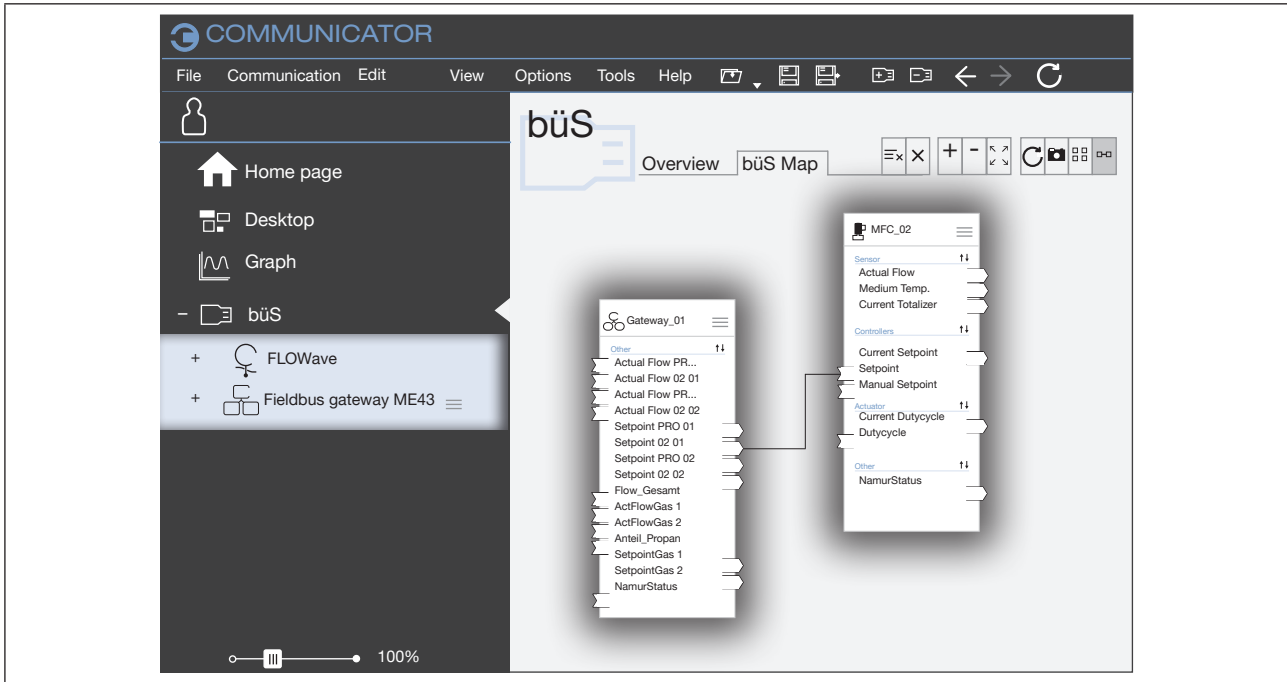

Figure 25: büS map

→ Parameterise the inputs and outputs via drag-and-drop.
 (Dotted connections have not yet established an active connection between the devices.
 Compatible connection points are highlighted in blue.)

→ Select **Apply changes**.

All configured devices are restarted.

✔ You have configured the büS network.

11 START-UP USING A WEB SERVER

Fieldbus gateway type ME43 has an integrated web server that provides functions for the configuration and display of status information.

The web server can be used for the following protocols:

- PROFINET
- EtherNet/IP
- EtherCAT
- Modbus TCP
- CC-Link IE field basic

The IP address of the device is used for access via the web server.

NOTE

Unauthorized access to the web server.

- ▶ To prevent unauthorized access by third parties, operate the device only within a protected network.

11.1 Function of the web server

The web server can be used to specify a number of settings (such as the IP address).

If the gateway configuration is created with Communicator (version 5.2 or higher), the web server shows an image of the entire system. The connected devices are depicted on an overview page. Clicking a device will open a device-specific page.

The web server displays basic data such as serial number, device type, etc. In addition, all cyclical and acyclic data declared during the gateway configuration are displayed. This only functions when the corresponding devices are also connected to the gateway during the web server access and connected via bÜS mapping. If a device is not present during access, a gap is left on the web server for the assigned device ID.

11.2 Deactivate to the web server via Bürkert Communicator

Web server can be enabled or disabled via Bürkert Communicator.

Web server > **Parameter** > **Activate web server**

11.3 Establishing a connection to the web server

→ Connect the PC to the device via a network cable.

→ Enter the IP address in the address line of the web browser.

The IP address of the device upon delivery is 192.168.0.100.

If the IP address is changed to an unknown value, the current IP address can be requested from the display of the device or determined with the help of Bürkert Communicator.

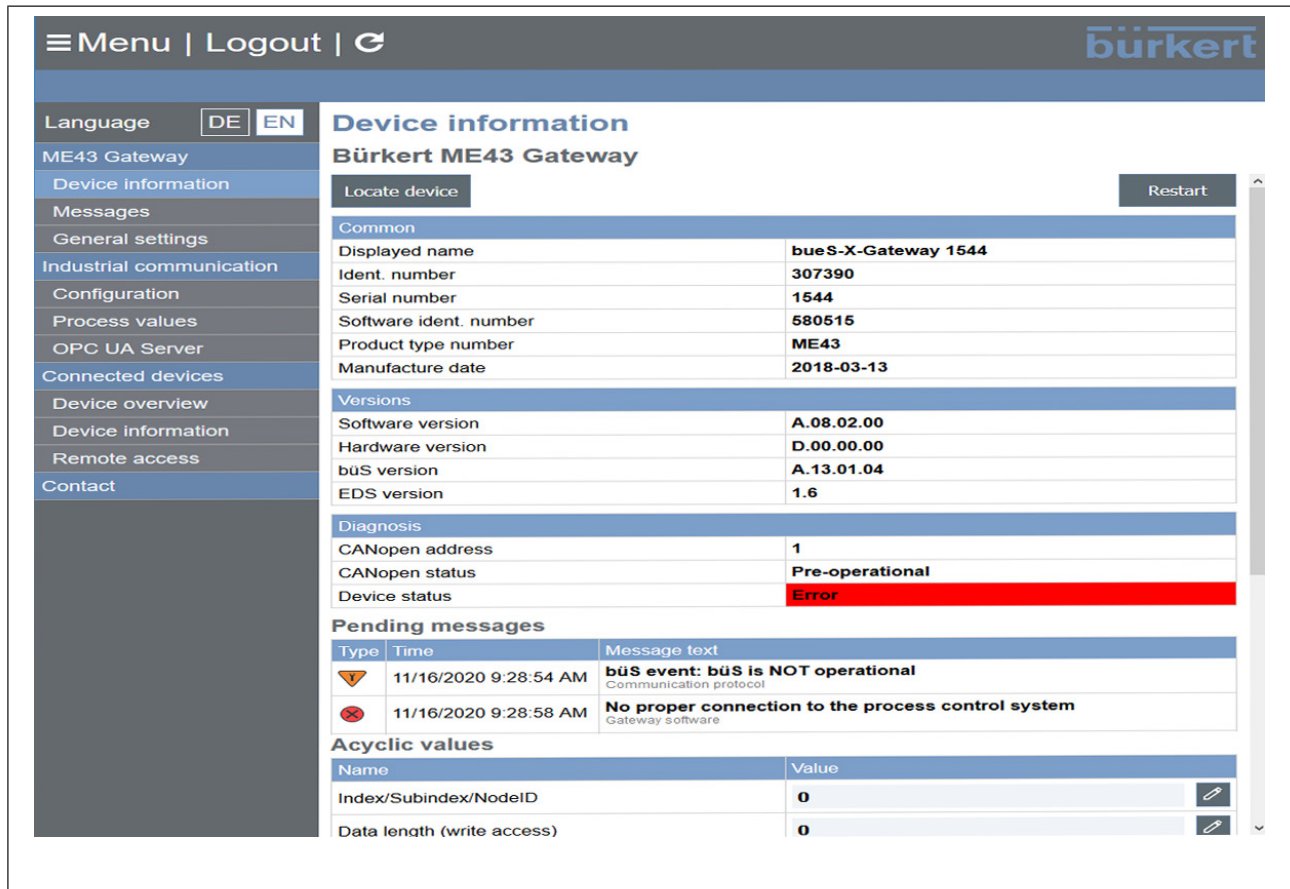

Figure 26: Web server view

11.4 Logging onto the web server

→ On the home page, click on **Login** on the top left.

→ Enter your user name and password: User name: admin
Password: admin (or MAC address)

→ Click on **Login**.

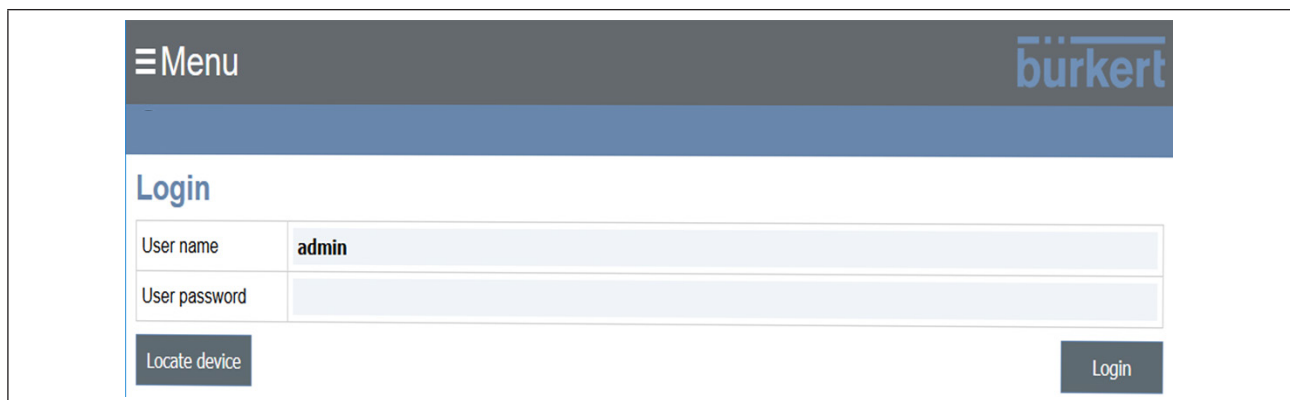

Figure 27: Logging onto the web server

11.5 Passwords

NOTE

Security risk due to standard passwords.

Unauthorized persons can log in to the web server and make changes to the system.

- ▶ Please change standard passwords.
- ▶ If the web server is not needed, disable access via Bürkert Communicator.

Web server > **Parameters** > **Deactivate web server.**

The following user names and passwords are active by default and are re-enabled when the passwords are reset:

Date of manufacture	before December 2020	after December 2021
User name	admin	admin
Standard password	admin	DC-B0-58-BA-DB-AD

11.5.1 Change password

→ Logging onto the web server.

→ Enter and confirm the new password in the menu **General settings**.

11.5.2 Factory reset of password

→ Click on **Login**.

→ On the bottom right of the login window, click on **Reset** passwords.

The device must be rebooted within 3 minutes so that the passwords can actually be reset. A restart can be triggered via the fieldbus gateway display, the Bürkert Communicator software or via a voltage reset.

11.6 Configuring the device



Creating the gateway configuration is not possible through the web server. The Communicator tool is required for this.

Configuring multiple devices:

Since the devices have the same IP address on delivery, only one unconfigured device is permitted in the network so that the device can be identified.

- ▶ Connect to the network and configure the devices individually in sequence.

→ Enter the device name and IP address for the device.

The device name (DNS compatible name) is used in the planning process.

→ Click **Apply**.

A voltage reset of the device is required to accept the changed parameters.

→ Restart the device.

12 OPC UA

12.1 General description

The OPC UA server offers an OPC UA client the possibility to read and write the values (cyclical and acyclic) determined by the gateway configuration.

To make the data of the ME43 and the connected büS devices available in an OPC UA client, the following points must be observed:

- A gateway configuration with Communicator version 5.2 or higher must be carried out, acyclic values can also be selected.
- Values that are available at the PLC via the set protocol and at the OPC client are identical and cannot be differentiated.
- A büS mapping must be performed after the gateway configuration. If büS devices are not connected to the gateway via mapping, the values and names of the devices cannot be exported.

12.2 Establish connection with OPC UA

The function for enabling or disabling the OPS UA server can be set in Bürkert Communicator:

OPC UA > **Parameters** > **Enable OPC UA**



Figure 28: Activate OPC UA

After enabling the OPC UA, other OPC UA server settings will become visible.

12.2.1 Settings on the device

IP parameters are set in the protocol-specific settings.

Detailed view	Menu	
Parameters	Activate OPC UA	OPC UA can be enabled or disabled here. The setting takes effect the next time the de
	Server port	Setting of the port for OPC UA communication. Status on delivery: 4840
	Number of objects being monitored	Used to limit the maximum number of values to be monitored by the OPC UA server
	Event type	Setting whether ME43 events should be sent and from which type. To be able to send events from connected büS devices, the corresponding types must be selected under General settings > System monitoring > Diagnostics

Table 8: Settings on the ME43 (OPC UA server)

! After changing the settings it is necessary to restart the device.

12.2.2 Settings for the OPC UA client

Endpoint URL	opc.tcp://*IP address of the ME43*:*specified server port (factory default setting: 4840)* Example: opc.tcp://192.168.0.100:4840
Security settings	
Security policy	none
Message Security Mode	none
Authentication settings	Anonymous

12.3 Server certificate

The OPC UA server offers the user the possibility to exchange the factory server certificate for his own. The exchange is possible via the web server.

Exchanging a certificate:

- Open the web server with the IP address of the ME43.
The certificate can only be changed after registration.
- Select **OPC UA Server**.
- Under **Server certificate** click the symbol and select the file in the format “DER”.
- Select **Change certificate**.

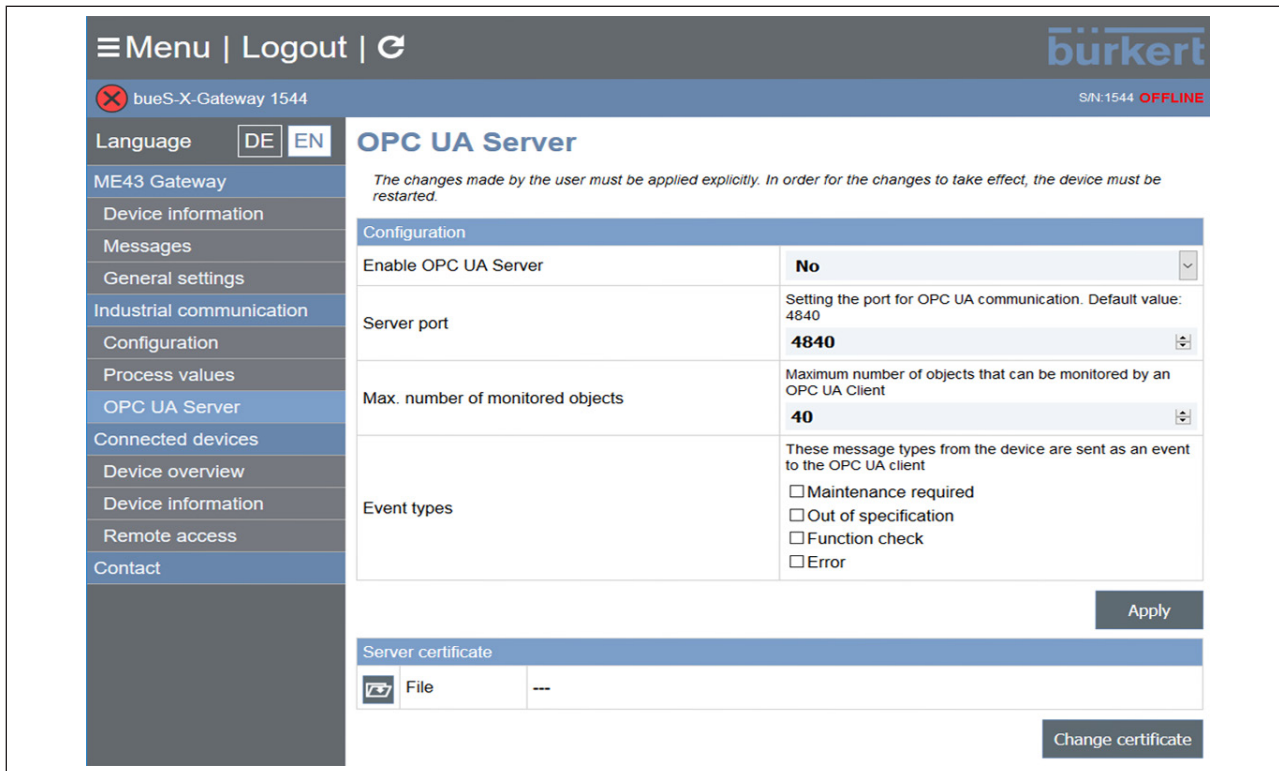

Figure 29: Change server certificate

MAN 1000328026 EN Version: | Status: RL (released | freigegeben) | printed: 28.02.2026



The device must be restarted after a successful exchange.

Delete user-specific certificate and set the factory certificate to active:

→ Click **Change certificate**.

→ Confirm with <OK>

After the restart, the factory certificate is loaded.

When resetting to factory defaults, the user-specific certificate is deleted and the factory certificate is set to active.

The user-specific certificate is not saved on a removable storage device and is therefore not transferred when the configuration is transferred to another device.

13 DISPLAY ELEMENTS

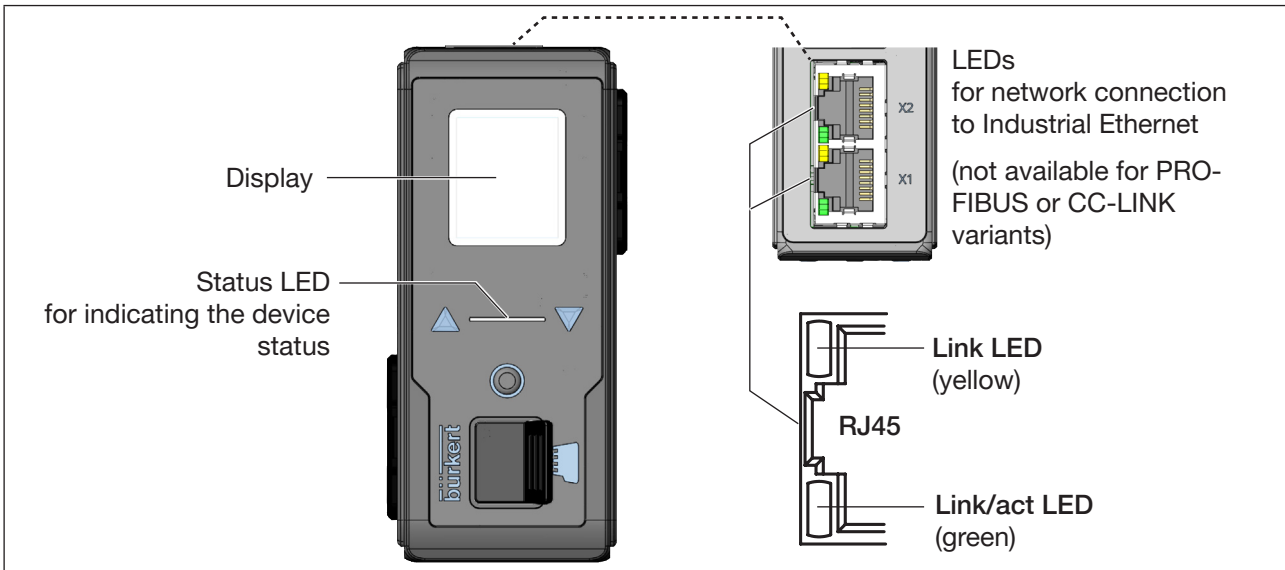

Figure 30: Overview of the display elements

13.1 LEDs for indicating the network connection to the Industrial Ethernet



The PROFIBUS variant and CC-Link variant do not have a status display for the connection to the network.

The connection to the network is made with a 9-pin D-Sub connector.

Description:

LED status		Description and cause of fault	Measure
Link LED (yellow)	Active	Connection to network active	-
	Not active	No connection to the network available.	Check cable
Link/act LED (green)	Active	Rapid flashing: Connection to the higher protocol layer (PRO-FINET, EtherNet/IP or Modbus-TCP) is established. Data being transmitted	
		Slow flashing, approx. 20 seconds after restart. No connection to the protocol layer available.	
	Not active	No connection to the network available.	Check cable

Table 9: Description: LEDs for the network connection

13.2 LED for displaying the device status

The LED that indicates the device status changes colour and status in accordance with NAMUR NE 107.

If several device statuses exist simultaneously, the device status with the highest priority is displayed. The priority is based on the severity of the deviation from standard operation (red = failure = highest priority).

Indicators in NAMUR operation mode:

Indication in line with NE 107		Description	Meaning
Colour code	Colour		
5	Red	Failure, error or fault	Functional fault. Device functionality is not guaranteed.
4	Orange	Function check	The device is searching for a bÜS participant. This status ends after a few seconds.
3	Yellow	Out of specification	The environment conditions or process conditions for the device are not within the specified range. Internal device diagnostics indicate problems within the device or with the process properties. Data sheet values cannot be complied with.
2	Blue	Maintenance required	The device has detected a deviation during ongoing diagnostics and has implemented a correction. Device functionality limited. The device is in closed-loop control mode, but function will soon be restricted. → Perform device maintenance.
1	Green	Diagnostics active	Device is in error-free operation. Status changes are highlighted in colour. Messages are sent via any fieldbus that may be connected.
0	White	Diagnostics inactive	Device is switched on. Status conditions are not displayed. Messages are not listed in the message list or transmitted via any connected fieldbus. Device is running within its specifications.

Table 10: Indication of the device status in NAMUR operation mode

13.3 Displays

	<p>Cyclic data traffic to the controller is active. The device is accessible via the IP address shown.</p>
	<p>Cyclic data traffic to the controller is inactive. The device is accessible via the IP address shown.</p>
	<p>The device is initialising (temporary information) or settings still need to be set. The device is accessible via the IP address shown.</p>
	<p>PROFINET S2 variant: P online: connected to Primary B online: connected to Backup</p>

14 BÜRKERT COMMUNICATOR MENUS

The following overview describes the device-specific settings for the type ME43 with the Bürkert Communicator software. It does not describe the basic operation of the software.



Detailed information on using the Bürkert Communicator software can be found on the Bürkert website at: www.burkert.com → 8920 → “Operating instructions” downloads.

The overview below shows the menus that are displayed in the “installer” user level. This user level has the highest authorisation level.

14.1 f(x) configuration

The configuration area f(x) configuration includes the menu for the configuration of other device functions.

The f(x) configuration enables functional extensions through free programming using a graphical programming interface.

Examples of functions are e.g. a timer, a graphical program or a controller.



Information and instructions for the f(x) configuration software can be found on the Bürkert homepage at: www.burkert.com → 8922 → Downloads “Operating instructions”.

14.2 “Web server” and “OPC UA”

The web server and OPC UA is only to be used for the following protocols:

- PROFINET IO
- PROFINET S2
- EtherNet/IP
- Modbus TCP

Enabling or disabling the web server:

Web server > **Parameters** > **Enable web server**

Enabling or disabling the OPC UA server:

OPC UA > Parameters > Enable OPC UA

When the OPC UA server is activated, the f(x) configuration is not available.

14.3 Configuration area “PROFINET”, “PROFINET S2”, “EtherNet/IP”, “EtherCAT” “Modbus TCP” and “CC-Link IE field basic”

Detailed view Parameters

Detailed view	Menu		
Parameters	PROFINET, PROFINET S2, EtherNet/IP, Modbus TCP or CC-Link IE field basic settings	Initiate Startup wizard for input check and set start conditions for bÜS communication.	
		IP parameter settings	
		Set DNS compatible name.	
		Set Fixed IP address.	
		Set Network mask.	
		Set Standard gateway.	
		Specify Temporary IP address.	
		MAC address is displayed.	
		Advanced settings	Alarm settings
			Internal cycle time
		Control mode settings	
		Firmware update protocol	
	Gateway configuration	Download a gateway configuration file	
		Create a gateway configuration	
Unit conversion			
Hide process values	Edit values to be hidden		
	Reset hidden values		
Acyclic routing settings			
Change protocol	Select Protocol		

Table 11: Settings in the “PROFINET” configuration area, parameters for detailed view

Detailed view Diagnostics

Detailed view	Menu	
Diagnostics	Configuration file information	
	Protocol	In these menus, the current values are displayed, not set.
	Communication status	
	Established connections to PLC	
	Current internal cycle time	
	Advanced	

Table 12: Settings in the “PROFINET” configuration area, diagnostics detailed view

Maintenance detailed view

Detailed view	Menu		
Maintenance	Version number	Stack name	In these menus, the current values are displayed, not set.
		Stack version	
		Stack build	
		Stack revision	
		Stack date	
		ICom version	
	Hardware reset of industrial communication		

Table 13: Settings in the “PROFINET” configuration area, maintenance detailed view

14.4 “EtherCAT” configuration area

Detailed view Parameters

Detailed view	Menu		
Parameters	EtherCAT settings	Initiate Startup wizard for input check and set start conditions for bÜS communication.	
		Station alias	
		MAC address is displayed.	
		Advanced settings	A Internal cycle time
			Control mode settings
			Firmware update protocol
	Gateway configuration	Download a gateway configuration file	
		Create a gateway configuration	
	Unit conversion		
	Hide process values	Edit values to be hidden	
		Reset hidden values	
Acyclic routing settings			
Change protocol	Select Protocol		

Table 14: Settings in the “EtherCAT” configuration area, parameters for detailed view

14.5 Configuration section “General settings”

Detailed view “Parameter”

Detailed view	Menu		
Parameters	Status LED	Set operation mode	
	bùS	Configuration of the bùS interface	
		Assign displayed name for display and Bürkert Communicator.	
		Location Specify location displayed for the device.	
		Description Enter description text for tooltips	
		Advanced	Unique device name for partner assignment.
			Specify Baud rate.
			Specify CANopen address.
			Bus mode Set operation mode of the bùS interface.
	Show errors from bùS partners Set whether and from which partners errors are displayed.		
	Deallocation delay Time from the loss of a partner until deletion of its configuration.		
	Alarm limits	Set limits after which the device issues a warning or error.	
		Supply voltage Set alarm limit for supply voltage.	
		Device temperature Set alarm limit for device temperature.	
		Warning of battery voltage below display of the value.	
	Diagnostics	Enabling or disabling diagnostics.	
	PDO configuration	Configuring process data objects	
		PDO 1	
		Reset to default values	
	Configuration provider	Status Enable or disable configuration provider.	
		Remove all device configurations Set response after device restart.	
		Force reconfiguration of all devices Set response after device restart.	
		Enable or disable Ignore offline devices.	
	Managing device functions	Disable industrial communication, web server and OPC UA to use the f(x) configuration.	
		Shows whether the f(x) configuration can be used with the current setting.	
	System monitoring	Diagnostics	
		Individual diagnostics of the system devices	
Display	Set Brightness, Contrast, Mounting position, Language		

Table 15: Settings in the “General settings” configuration area, parameters detailed view

Detailed view “Diagnostics”

Detailed view	Menu			
Diagnostics	Device status	Operating duration	In these menus, the current values are displayed, not set.	
		Device temperature		
		Supply voltage		
		Voltage drops		Number since restart.
		Min./max. values		Max. temperature
				Min. temperature
				Max. Supply voltage
				Min. Supply voltage
		Device start counter		
		Removable storage medium status		
		Current system time		
		Battery voltage		
	bÜS status	Receive errors	Number since restart.	
		Max. receive errors	Most serious receive error that was issued in the same way as the device status is displayed. The display can be reset to 0.	
		Send errors	Number since restart.	
		Max. send errors	Most serious send error that was issued in the same way as the device status is displayed. The display can be reset to 0.	
		Reset error counter		
	CANopen status	operational or pre-operational		
	Logbook	<p>The logbook lists all warning messages and error messages with details of the type, time and signature.</p> <p>The messages displayed in the logbook can be updated, saved and deleted.</p>		
	Configuration provider	Status	In these menus, the current values are displayed, not set.	
		Managed devices		
		- Thereof offline configurations		
		- Thereof ordered reconfigurations		
Reconfigured devices				
Loaded device configurations				
Missing devices				
Faulty configuration load processes		since restart		
Faulty reconfigurations				
Removable storage medium status				

Table 16: Settings in the “General settings” configuration area, diagnostics detailed view

Maintenance detailed view

Detailed view	Setting				
Maintenance	Device information	Displayed name only displayed if a name was entered in the menu of the same name for the Parameters detailed view.		In these menus, the current values are displayed, not set.	
		Identification number			
		Serial number			
		Software ident. number			
		Software version			
		bùS version			
		Hardware version			
		Product type			
		Manufacturing date			
		eds version			
		f(x) version			
		Device driver	Driver version		
			Firmware group		
		DLL version			
		Place of origin			
Reset device	Restart				
	Factory reset				

Table 17: Settings in the “General settings” configuration area, maintenance detailed view

15 REPLACING THE DEVICE

WARNING

Risk of injury due to improper work on the device.

- ▶ The device may only be replaced by trained specialists with suitable tools.
- ▶ Secure the system against unintentional activation.
- ▶ Ensure a controlled restart after replacing the unit.

1. Switch off the supply voltage.
2. Remove 5-pin spring-loaded terminal.

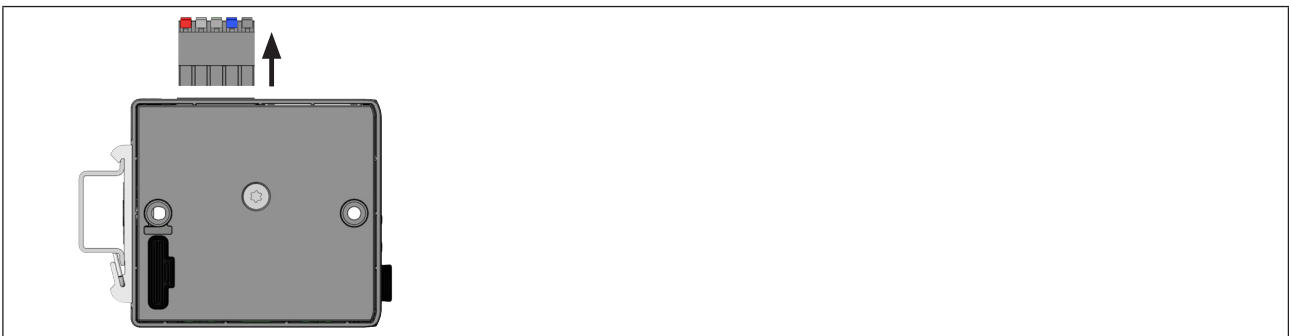

Figure 31: Remove 5-pin spring-loaded terminal

3. Remove the Ethernet cable from the X2 and X2 interfaces.
On PROFIBUS variant and CC-Link variant: Remove D-Sub, 9-pin push-in connector.

4. Remove the device from the standard rail.

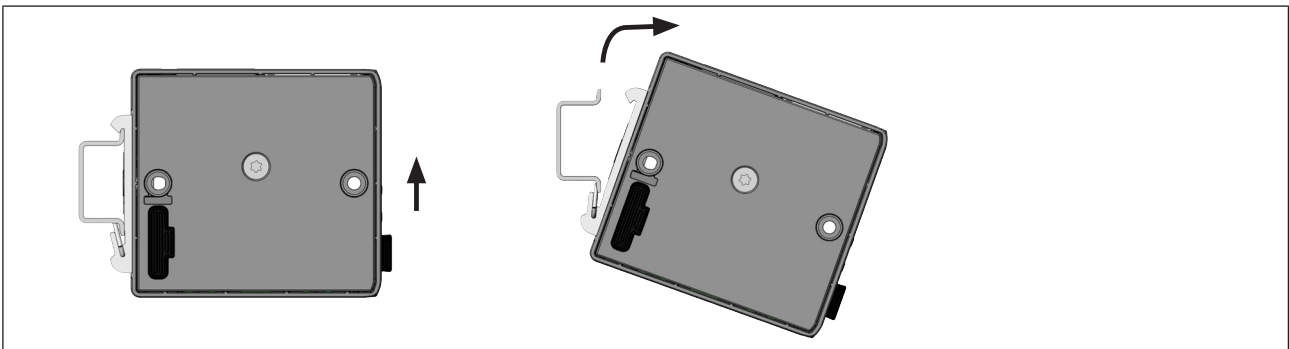

Figure 32: Removing device from standard rail

→ Push the device upward and detach it from the upper guide of the standard rail.

5. Remove the micro SD card.

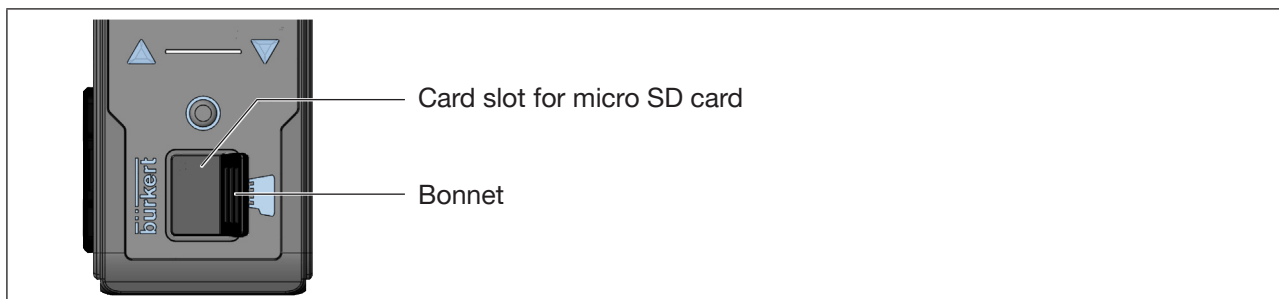

Figure 33: Change micro SD card; ME43 fieldbus gateway

- Pull the bonnet carefully out of the recess.
- Turn the bonnet away from the top left.
- To unlock, press on the edge of the engaged micro SD card.
- Remove the micro SD card.

6. Insert the micro SD card into the replacement device:

- ⚠ Observe the direction of insertion when inserting the card.
- Slide the micro SD card into the card slot. Make sure that the micro SD card locks into position.
- Close card slot with bonnet.

7. Install the replacement device on the standard rail

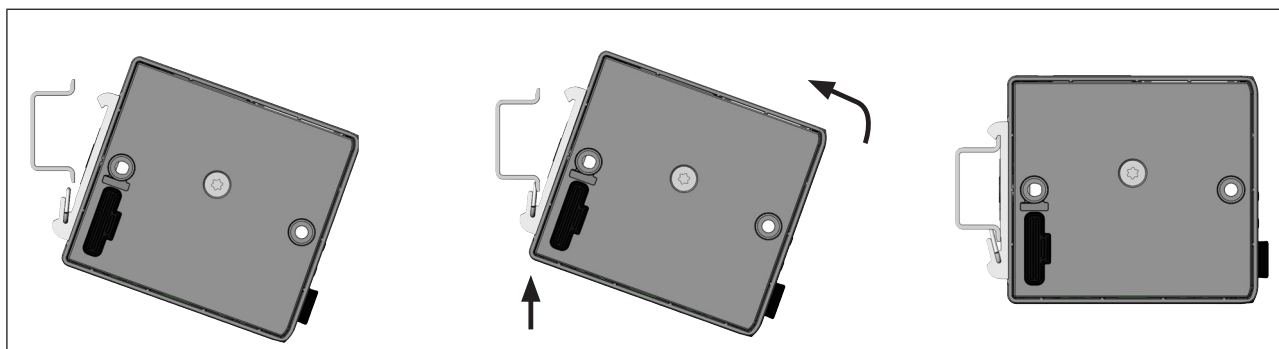

Figure 34: Install the device on the standard rail

- Tilt the device to the right and align it with the standard rail.
- Hook the device into the lower guide of the standard rail.
- Push the device upward while tilting it to the left and lock it into the upper guide of the standard rail.

8. Electrically connect the device

- Connect the 5-pin spring-loaded terminal to the device.
- Plug the Ethernet cables into sockets X1 and X 2 (for RJ45 push-in connectors).
On PROFIBUS variant and CC-Link variant: Plug in D-Sub, 9-pin push-in connector.
- Connect supply voltage.

16 TROUBLESHOOTING

Problem	Possible cause	Measure
NAMUR LED goes out periodically.	The power supply drops out periodically; the device implements a reset each time.	Use power supply with adequate power.
	The voltage drop in the connection cable is too great.	Increase cable cross-section. Reduce cable length.
No process values are transmitted between Industrial Ethernet and bÜS.	No cable connection	Check the Ethernet and bÜS cabling.
	The reading and writing of the values has not been enabled by the PLC in the control object of the device.	Enable the reading and writing of the values in the control object of the device.
	The process values are incorrectly configured.	Check the configuration of the process values.
	The process values are incorrectly assigned.	Check the assignment of the process values to the bÜS participants.
The process values cannot be assigned to the bÜS participants.	The process values are not configured.	Check the configuration of the process values.
	The transfer of the configuration must be ended with a restart of the device.	Reboot the device after configuration.
	The process values are assigned to different classes.	Check the assignment to ensure that the bÜS participants are using process values of the same class.
	The input and output direction must be observed as the assignment.	Check that the direction of the input and output is correct.
An incorrect value is applied or the value is zero.	The process values are not assigned or are assigned to the wrong participants.	Check the assignment of the process values.
Replacement device does not adopt any values of the micro SD card from the defective device.	The identification numbers of the replacement device and the defective device are different.	Only values between devices with the same ID can be transferred.
	The micro SD card is defective. The device was not able to write any values to the micro SD card.	Replace the micro SD card (see Chapter “17 Accessories”) and try again to transfer the parameters of the defective device to the micro SD card (see “9.5 Using the micro SD card to transfer and save data”).
Replacement device does not adopt all values of the micro SD card from the defective device.	The replacement device and defective device have different EDS device descriptions.	Only the existing values on the defective device can be copied to the replacement device. New replacement device values must be parameterized using the Bürkert Communicator software.

Table 18: Troubleshooting

16.1 Description of the error code

Error code	Description
1/3	Overload detected.
2/1	Overvoltage detected.
2/2	Undervoltage detected.
2/3	Voltage warning limit exceeded.
2/4	Voltage warning limit undershot.
2/5	Battery voltage warning limit undershot.
2/6	Voltage drop detected.
3/1	Excess temperature detected.
3/2	Low temperature detected.
3/3	Temperature warning limit exceeded.
3/4	Temperature warning limit undershot.
18/4	SD card is defective.
18/7	Removable storage present.
18/8	No access to the removable storage possible.
18/9	Configuration is being successfully managed by another device.
18/10	Configuration is NOT being successfully managed by another device.
18/11	Unable to load device configuration via the configuration provider.
18/12	At least 1 device is missing.
18/13	Bürkert Communicator is required.
18/14	Device must be replaced.
18/15	Device cannot be replaced as there are too many options present. Reduce the number of compatible devices.
18/16	Problems when replacing device.
18/17	Problems when replacing device. Unable to write to at least 1 object.
18/18	Device replacement failed.
18/19	Device replacement completed successfully.
18/20	Configuration provider is not active as no memory card has been detected.
18/21	More than 1 configuration provider is active! Switch off the other provider functions.
32/1	Capacity of the internal message storage exceeded.
32/130	Initialisation of the device.
33/1	Switch to "Operation" state
33/2	Switch to "Diagnostics active" state.
33/3	Switch to "Maintenance" state
33/4	Switch to "Out of specification" state.
33/5	Switch to "Check function" state.
33/6	Switch to "Error" state
33/7	Switch to AUTO operating state.
33/8	Switch to MANUAL operating state.
33/9	Switch to special operation mode: LED flashing.
33/11	Switch to "off" state.

Error code	Description
33/12	Input value simulation active for at least 1 value.
33/13	Output value simulation active for at least 1 value.
33/14	Demo operation mode enabled.
33/15	User-triggered maintenance signal.
33/32768	1 status message present.
35/1	EEPROM error detected.
35/2	At least 1 persistent memory cannot be used.
40/996	Error on 1 or more partner device(s).
45/128	General mailbox overrun.
45/1280	büS event: BDO message buffer overrun.
45/129	büS mailbox overrun.
45/130	CANopen mailbox overrun.
45/131	CANopen response mailbox overrun.
45/132	Event mailbox overrun.
45/133	CSDO response mailbox overrun.
45/134	BDO response mailbox overrun.
45/145	CAN-controller message buffer overrun.
45/15	Message/Data length error.
45/16	Failed to send message.
45/17	Message response timed out
45/176	CAN error counter overrun -Bus Off.
45/177	Receive queue overrun.
45/178	Transmit queue overrun.
45/256	büS event: büS is NOT operational.
45/257	büS event: initialisation of communication.
45/3	General error.
45/4	Wrong büS status.
45/5	CANopen task command failed.
45/512	büS event: localisation.
45/6	Wrong parameter passed to function.
45/768	büS event: a device is using the same address.
45/769	büS event: a device uses the same serial number.
45/1024	büS event: bus connection lost/not available.
45/1792	büS event: partner search active.
45/1793	büS event: producer(s) not found.
45/1794	büS event: manually configured device without address. The search can take up to 1 minute.
45/1795	büS event: producer assignment faulty.
45/1796	büS event: removal of the producer failed.
45/1797	büS event: incorrectly configured CANopen device.
45/1798	büS event: GCV is configured on both büS interfaces.
45/1799	büS event: cyclical communication of the producer is not active.

Error code	Description
45/2048	büS event: saving of persistent büS data (do not switch off device).
45/2049	büS event: deletion of persistent büS data (do not switch off device).
45/2304	büS event: router for acyclickonfigurier data active.
45/2560	büS event: incorrect serial number.
45/2561	büS event: incorrect configuration of cyclical inputs (not enough filters).
45/2562	büS event: incorrect configuration of cyclical values.
45/2816	büS event: manager is active.
45/3072	büS event: monitored device failed.
45/3584	Wait for addressing.
45/4096	Error when initialising the device parameters.
45/4097	Configured address is already being used.
51/1	No correct connection to the process control system.
51/2	The cyclical data traffic was slower than the set timeout parameters.
51/10	Initialisation of the industrial communication.
51/101	Error in the NetX configuration, e.g. when downloading the firmware.
51/102	The industrial communication is switched off.
51/103	No or incorrect mapping file present.
51/104	No protocol firmware available.
51/105	Please select a protocol and restart the device.
51/201	Protocol stack initialisation error.
51/202	Protocol stack configuration error.
51/203	Error sending the MAC address.
51/204	Error registering the object data.
51/205	Error registering the connections, more than 5 specified.
51/206	Incorrect PROFIBUS address, only addresses 1–126 possible.
51/207	Incorrect CC-Link address, only addresses 1–64 possible.
51/208	Incorrect CC-Link baud rate.
51/209	Faulty IP parameter.
51/300	The fieldbus master is in “Stop” state.
51/303	Error during cyclical data exchange.
51/400	The master attempted to connect a faulty module/sub-module.
52/2	Missing EDS extension entries for the f(x) function, reconfiguration required.
52/3	Function use data CRC error, re-configuration required.
52/4	Functionality could not be generated (unknown functionality?).
52/5	Functionality could not be initialised.
52/6	f(x) configuration incorrect, reconfiguration required.
52/7	Function number invalid, re-configuration required.
52/10	The usage data cache of f(x) is full; reduce the number of functions or the program size.
52/11	Error in calculating the function.
52/12	User message.
52/13	Function calculated for longer than its cycle time and has been disabled! Increase the cycle time where necessary.

Error code	Description
52/15	The cycle times of the graphical f(x) program do not correspond to the associated function cycle time. Re-load the program back onto the device.
52/16	f(x) mapping is incorrect (mapping table invalid), reconfiguration required.
52/17	f(x) function waits for producers. (Are all inputs linked?)
52/18	Graphical program editor: no program loaded, load a program to the device.
52/19	One f(x) function has an error! (Correct the other current errors)
52/20	The cycle time of one f(x) function is too long! The cycle time must be shortened to avoid irreparable damage to the device.
52/21	Graphical program editor: licence for program not adequate! To enable full functionality, please contact the Bürkert sales department!
52/22	Graphical program editor: invalid persistent data! Default values will be used.
52/23	Graphical program editor: program and program configuration do not match, re-configuration required.
52/24	Graphical program editor: no licence. The program will be disabled after running for one hour.
52/25	Graphical program editor: no licence. The program has been closed! To enable full functionality, please contact the Bürkert sales department!
52/26	Initialising f(x).
63/10	At least one bÜS device is in state: Maintenance.
63/11	At least one bÜS device is in state: Out of specification.
63/12	At least one bÜS device is in state: Functional test.
63/13	At least one bÜS device is in state: Error.
63/20	F(x) function not usable while OPC UA is enabled.

Table 19: Description of the error code

16.2 Status indicators and measures

Displaying the status LED based on NAMUR NE 107	Description	Measure
No colour	No power is supplied to the device.	Power is supplied to the device.
Flashing (applies to all colours)	The device was selected using the Bürkert Communicator software.	Deselect the device in Bürkert Communicator.
Red	Device defective.	Device requires maintenance – contact the manufacturer.
	Communication with other bÜS participants not possible.	Connect device to a network with other bÜS participants.
	Bus error (e.g. short circuit).	Check cables.
	The device has no connection to the PLC.	Check cables. Check device description for the device connection to the PLC.
	Device cannot find the assigned bÜS participant.	Check whether the bÜS participant is assigned to the device.
Orange	Search for bÜS participants is active. Status ends after a few seconds.	If the device status lasts longer than 4 minutes, restart the network.
Yellow	Device temperature outside of specification, destruction of device cannot be ruled out.	Operate the device within the specifications.
	Internal device diagnostics indicate problems within the device or with the process properties.	Perform measure according to logbook notifications.
Blue	Maintenance required	Perform device maintenance.

Table 20: Measures for displaying device status

LED status		Description and cause of fault	Measure
Link LED (yellow)	Not active	No connection to the network available	Check cable.
Link/Act LED (green)	Not active	No connection to the network available.	Check cable.

Table 21: LEDs for network connection and measures

17 ACCESSORIES



CAUTION

Risk of injury and/or damage due to incorrect parts.

Incorrect accessories and unsuitable spare parts may cause personal injuries and damage to the device and the area around it.

- ▶ Use only original accessories and original spare parts from Bürkert.

Accessories	Order number
USB büS interface set 1 (including power supply and Bürkert Communicator software)	772426
Micro SD card	774087
Adapter spring-loaded terminal to M12 (5-pole) 0.1m	584765

18 DISASSEMBLY

WARNING

Risk of injury due to improper disassembly.

- ▶ Disassembly must only be performed by trained technical personnel.

1. Switch off the supply voltage
2. Remove 5-pin spring-loaded terminal.



Figure 35: Remove 5-pin spring-loaded terminal

3. Remove the Ethernet cable from interfaces X2 and X2.
On PROFIBUS variant and CC-Link variant: Remove D-Sub, 9-pin push-in connector.

4. Remove the device from the standard rail

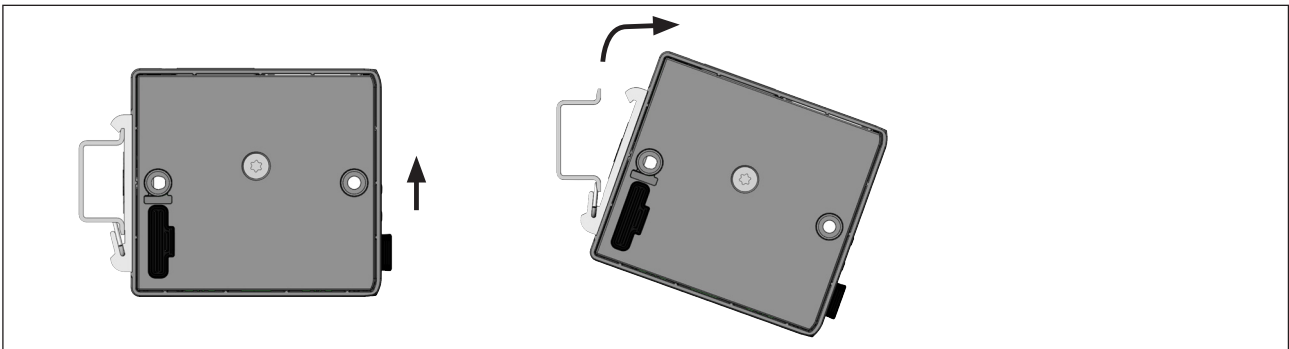

Figure 36: Removing device from standard rail

→ Push the device upward and detach it from the upper guide of the standard rail.

19 TRANSPORTATION, STORAGE, DISPOSAL

NOTE

Damage in transit due to inadequately protected devices.

- ▶ Protect the device against moisture and dirt in shock-resistant packaging during transportation.
- ▶ Observe permitted storage temperature.

Incorrect storage may damage the device.

- ▶ Store the device in a dry and dust-free location.
- ▶ Storage temperature: -30 °C...+80 °C.

NOTE

Damage to the environment caused by device parts that are contaminated with media.

- ▶ Dispose of the device and packaging in an environmentally-friendly manner.
- ▶ Observe applicable disposal and environmental regulations.

Environmentally friendly disposal



- ▶ Follow national regulations regarding disposal and the environment.
- ▶ Collect electrical and electronic devices separately and dispose of them as special waste.

Further information country.burkert.com.

