

FLAWSIC100 Gas Flow Measuring Instrument



Description
Installation
Operation



Document Information

Product

Product name: FLOWSIC100

Document ID

Title: Operating Instructions FLOWSIC100
Part No.: 8012513
Version: 2-2
Release: 2019-02

Manufacturer

SICK Engineering GmbH
Bergener Ring 27 · D-01458 Ottendorf-Okrilla · Germany
Phone: +49 35205 52410
Fax: +49 35205 52450
E-Mail: info.pa@sick.de

Original documents

The English version 8012513 of this document is an original document from SICK Engineering GmbH.
SICK Engineering GmbH assumes no liability for the correctness of an unauthorized translation.
In case of doubt, please contact SICK Engineering GmbH or your local representative.

Legal information

Subject to change without notice.

© SICK Engineering GmbH. All rights reserved.

Warning Symbols



Warning

Warning Levels / Signal Words

HAZARD

Risk or hazardous situation which *will* result in severe personal injury or death.

WARNING

Risk or hazardous situation which *could* result in severe personal injury or death.

CAUTION

Hazard or unsafe practice which *could* result in personal injury or property damage.

NOTICE

Hazard which *could* result in property damage.

Information Symbols



Important technical information for this product



Important information on electric or electronic functions



Supplementary information

1	Important information	7
1.1	Intended use.....	8
1.2	Responsibility of user.....	8
1.2.1	General information.....	8
1.3	Safety information and protective measures.....	9
1.3.1	General information.....	9
1.3.2	Hazard through electrical equipment.....	9
1.3.3	Hazard through hot, corrosive and/or pressurized gases.....	9
1.3.4	Hazards through ultrasonic signals.....	10
1.3.5	Behavior in case of failure of purge air/cooling air supply.....	10
1.3.6	Detecting malfunctions.....	10
1.3.7	Preventing damage.....	10
2	Product description	11
2.1	System features and areas of application.....	12
2.2	System overview and functional principle.....	13
2.2.1	System overview.....	13
2.2.2	Communication between sender/receiver units and control unit.....	14
2.2.3	Functional principle.....	15
2.3	System components.....	17
2.3.1	FLSE100 sender/receiver unit.....	17
2.3.1.1	Standard sender/receiver units.....	22
2.3.1.2	Sender/receiver units with internal cooling.....	25
2.3.1.3	Purged sender/receiver units.....	27
2.3.2	Flange with tube.....	28
2.3.3	Weatherproof cover.....	29
2.3.4	MCU control unit.....	29
2.3.5	Connection cable.....	39
2.3.6	Purge air unit accessory.....	40
2.3.7	Option “Cooling air supply in junction box” for internally cooled device types.....	40
2.3.8	Cooling air control option for device types M-AC and H-AC.....	41
2.3.9	Optional sets for emergency air supply for device types with cooling and purge air operation.....	41
2.3.9.1	Emergency air supply for device types M-AC and H-AC.....	42
2.3.9.2	Emergency air supply for device types PM, PH and PH-S.....	43
2.3.10	Measuring tube option.....	43
2.4	Computations.....	44
2.4.1	Calculating and calibrating the volume flow.....	44
2.4.2	Temperature calibration.....	45
2.4.3	Damping time.....	46
2.5	Check cycle.....	47
2.5.1	Zero point control.....	47
2.5.2	Span test.....	48
2.5.3	Check cycle output on the analog output.....	48

3	Assembly and installation	49
3.1	Project planning	50
3.1.1	Determining the measurement and installation location	51
3.1.2	Further planning information	54
3.1.3	Selecting the flanges with tube	57
3.2	Assembly	60
3.2.1	Installing the flanges with tube	60
3.2.1.1	Duct/pipe diameter > 0.5 m	60
3.2.1.2	Duct/tube diameter < 0.5 m	63
3.2.2	Installing the control unit MCU	66
3.2.3	Installing the junction box	67
3.2.4	Installing the sender/receiver units	67
3.2.5	Installation of the weatherproof cover for the sender/receiver units	68
3.2.6	Installing the purge air unit accessory (device types PM, PH, PH-S)	69
3.2.7	Installing the emergency air supply option for device types PM, PH and PH-S	70
3.2.8	Installing the weatherproof cover for the purge air unit accessory	72
3.2.9	Installation of impact protector/dust protector option	73
3.2.9.1	Impact protection for FLSE100-H, HAC, PH and PHS	73
3.2.9.2	Dust protector for FLSE100-PR	75
3.2.10	Installation of solid-borne noise damping set option K100/K75	75
3.3	Installation	78
3.3.1	General instructions, prerequisites	78
3.3.2	Installing the cooling air/purge air supply	78
3.3.2.1	Control unit MCU-P with integrated cooling air supply (device types M-AC and H-AC)	78
3.3.2.2	Separate cooling air supply in junction box (device types M-AC and H-AC)	79
3.3.2.3	Purge air unit (device types PM, PH, PH-S)	80
3.3.2.4	Installing the purge air and cooling air reducer option	81
3.3.3	Installing the cooling air control option for device types M-AC and H-AC	82
3.3.4	Installing optional sets for emergency air supply for devices with cooling air/purge air operation	87
3.3.4.1	Emergency air supply for device types M-AC and H-AC	87
3.3.4.2	Emergency air supply for device types PM, PH and PHS	93
3.3.5	Installing the sender/receiver unit	95
3.3.6	Connecting the control unit MCU	97
3.3.7	Connecting the control unit in a 19" housing	102
3.3.8	Terminating the sender/receiver units when operating the FLOWSIC100 with "2-path measuring" configuration	106
3.3.8.1	Checking the sender/receiver unit(s) - MCU connection	106
3.3.8.2	Bus addressing	107
3.3.8.3	Hardware addressing	107
3.3.9	Installing and connecting the interface and I/O module options	108

4	Start-up and parameter settings	113
4.1	Basics	114
4.1.1	General information	114
4.1.2	Installing SOPAS ET	114
4.1.3	Connecting the device	116
4.1.3.1	Changing the language	116
4.1.3.2	Connecting to the device via the “Device family” mode (recommended search settings)	117
4.1.3.3	Connecting to the device with advanced mode	119
4.1.4	Information on using SOPAS ET	122
4.2	Standard start-up procedure	126
4.2.1	Setting “Maintenance” mode	127
4.2.2	Setting the system data parameters on the FLOWSIC100 sensor	127
4.2.3	Setting the check cycle parameters	130
4.2.4	Configuring the analog output	131
4.2.5	Configuring the analog inputs	133
4.2.6	Setting the damping time	134
4.2.7	Data backup	134
4.2.8	Starting normal measuring operation	138
4.2.9	Signal waveform	138
4.3	Advanced start-up	144
4.3.1	Changing the application setting	144
4.3.2	Configuring optional analog modules	145
4.3.3	Configuring the optional interface module	146
4.3.4	Configuring the Ethernet module	147
4.3.4.1	Changing the field bus address for the Profibus module	149
4.3.5	Configuring the temperature curve for the cooling air control option for device types M-AC and H-AC	150
4.3.6	Calibrating flow rate and temperature measurement	151
4.4	Operating / Configuring with the LC-Display option	152
4.4.1	General information on use	152
4.4.2	Menu structure	153
4.4.3	Configuring	154
4.4.4	Changing the application setting	154
4.4.5	Changing the display settings with SOPAS ET	155

5	Maintenance	157
5.1	General information	158
5.2	Maintaining the sender/receiver units.....	159
5.2.1	Removing the sender/receiver units.....	159
5.2.2	Cleaning the sender/receiver unit	160
5.3	Maintaining the cooling air supply of the internally cooled types M-AC and H-AC.....	161
5.3.1	Inspection	161
5.3.2	Control unit with integrated cooling air supply	162
5.4	Maintaining the external purge air unit accessory	163
5.4.1	Inspection	163
5.4.2	Replacing the filter element	164
6	Specification	165
6.1	Technical Data	166
6.2	Standard components	168
6.3	Dimensions, Part No.	169
6.3.1	Sender/receiver units	169
6.3.2	Flange with tube	174
6.3.3	MCU control unit.....	176
6.3.4	Cooling air supply in junction box for FLOWSIC100 M-AC + H-AC.....	179
6.3.5	Junction box for connection cable	180
6.3.6	Miscellaneous.....	182
6.3.7	Control unit, MCU 19“	183
6.3.8	Consumable parts for 2-years operation	183
6.3.9	Control unit MCU with integrated purge air supply	183
6.3.10	External purge air unit accessory	183

FLWSIC100

1 Important information

Intended use
Responsibility of user
Safety information and protective measures

1.1 Intended use

Purpose of the device

The FLOWSIC100 measuring system is designed for no-contact measurement of the gas flow rate and air temperature in pipelines, flue gas and exhaust gas ducts, as well as stacks.

Correct use

- ▶ Use the device only as described in these Operating Instructions. The manufacturer bears no responsibility for any other use.
- ▶ Carry out all measures required to maintain the device, e.g. maintenance and inspection, transport and storage.
- ⊗ Do not remove, add or modify any components to or on the device unless described and specified in the official manufacturer information. Otherwise:
 - The device could become dangerous.
 - Any warranty by the manufacturer becomes void.

1.2 Responsibility of user

1.2.1 General information

Designated users

The FLOWSIC100 measuring system may only be operated by skilled technicians who, based on their technical training and knowledge as well as knowledge of the relevant regulations, can assess the tasks given and recognize the hazards involved.

Special local conditions

- ▶ The relevant legal stipulations and associated technical regulations must be observed when preparing and carrying out work on the respective system
- ▶ All work must be carried out in accordance with the local, system-specific conditions and with due consideration paid to the operating dangers and specifications.

Retention of documents

The Operating Instructions for the measuring system as well as system documentation must be kept on site and be available for reference. Pass the respective documentation on to any new owner of the measuring system.

1.3 **Safety information and protective measures**

1.3.1 **General information**

Handling or using the device incorrectly can result in personal injury or material damage. Read this Chapter carefully and ensure you observe the safety precautions during all work on the FLOWSIC100. Always observe the warnings provided in these Operating Instructions.

The following applies at all times:

- The relevant legal stipulations and associated technical regulations must be observed when preparing and carrying out work on the installation.
- Pay particular attention to potentially hazardous aspects of the equipment, such as pipelines and ducts with overpressure and hot gas. The applicable special regulations must be followed at all times.
- All work must be carried out in accordance with the local, system-specific conditions and with due consideration paid to the operating dangers and specifications.
- The Operating Instructions for the measuring system as well as system documentation must be available on site. The instructions for preventing danger and damage contained in these documents must be observed at all times.

1.3.2 **Hazard through electrical equipment**

The FLOWSIC100 measuring system is an item of electrical equipment designed for use in industrial high-voltage systems. Make sure the power supply is switched off before working on power connections or live components. If necessary, replace shock protection measures before reconnecting the power supply.

1.3.3 **Hazard through hot, corrosive and/or pressurized gases**

The sender/receiver units are mounted directly on the gas-carrying duct. On equipment with low hazard potential (no danger to health, ambient pressure, low temperatures), the installation or removal can be performed while the equipment is in operation providing the valid regulations and equipment safety notices are observed and suitable protective measures are taken.

	<p>WARNING:</p> <p>Systems and processes with toxic gases, high pressure or high temperatures must be shut down before the sender/receiver units are installed or removed.</p>
---	---

	<p>CAUTION: Health risk through hot gas</p> <ul style="list-style-type: none"> ● Hot gas can escape should the purge air supply fail when using externally purged devices (device types PM, PH and PH-S) in pressurized pipelines and ducts. This can lead to serious damage to health and material damage to the system. The system owner must take suitable protective measures to prevent such damage. Technical solutions for the FLOWSIC100 to prevent gas escaping should the purge air fail are available from the manufacturer on request. ● Heated cooling air escapes when internally cooled sender/receiver units are used. Risk of burns and damage to health are possible! The system owner must take suitable protective measures to prevent such damage.
---	--

Subject to change without notice

1.3.4 Hazards through ultrasonic signals

Do not expose unprotected hearing to the sonic beam of the transducer (especially type H). Wearing suitable hearing protection is recommended when inspecting the duct, connecting the device outside the duct or similar activities.

1.3.5 Behavior in case of failure of purge air/cooling air supply

Some system versions are equipped with a purge air and/or cooling air unit to protect the ultrasonic transducers from hot or corrosive gases. The transducers can be severely damaged should the purge air supply fail. For this reason, the operator must ensure:

- The power supply for the purge air/cooling air unit operates reliably and without interruption,
- A failure of the purge air/cooling air supply is detected immediately (for example, by using pressure controllers)
- The sender/receiver units are removed from the duct in the event of a purge air/cooling air failure and the duct openings are covered (for example, with a flange cover).

1.3.6 Detecting malfunctions

Any deviations from normal operation must be regarded as a serious indication of a functional impairment. These include:

- Significant drifts in the measuring results.
- Increased power input.
- A rise in system component temperatures.
- Triggering of monitoring devices.
- Unusually strong vibrations or unusual operating noise from a purge air/cooling air blower
- Smoke or unusual odors.

1.3.7 Preventing damage

To prevent personal injury or damage to the system, the operator must ensure:

- The maintenance personnel responsible can reach the site immediately, and at any time.
- The maintenance personnel is sufficiently qualified to respond to malfunctions on the FLOWSIC100 and any resulting operational malfunctions.
- In case of doubt, switch the defective equipment off immediately.
- Switching off the equipment does not indirectly cause further malfunctions.

FLWSIC100

2 Product description

System features and areas of application

System overview and functional principle

System components

Computations

Check cycle

2.1

System features and areas of application

The FLOWSIC100 measuring system conducts simultaneous measurements of the gas flow rate and temperature. The volume flow under actual conditions can be calculated and output from the gas flow rate by including the gas temperature and internal duct pressure in the standard state.

Features and benefits

- Modular design
By selecting the right modules, you can combine the components to suit your application and fulfill a wide range of requirements. As a result, the FLOWSIC100 can be used for very many applications.
- Integrated measurement of the gas flow rate across the duct diameter, independent of the pressure, temperature, and gas composition
- Digital processing of measured values ensures high accuracy and low susceptibility to interference
- Self-test by means of automatic check cycle
- No pressure-reducing fittings in the gas flow, which ensures the gas flow is not disrupted
- Easy to install
- Low wear and tear by selecting the most suitable modules for the application
- Minimum maintenance requirements

Applications

The measuring devices in the FLOWSIC100 series can be used to measure gas flows in pipelines, flue-gas and exhaust gas ducts, as well as chimneys. If configured accordingly, the devices can measure the flow rate in both clean and raw gases upstream of filter installations. As a result, applications range from determining the volume flow in open and closed-loop control systems used in process control to flow monitoring for emission measurements.

The system is suitable for use in the following areas:

- Operating measurements and emissions monitoring in:
 - Energy supply: Power station and industrial boilers for all energy sources
 - Waste disposal: Waste and residual waste incineration plants
 - Basic industries: Systems in the cement and steel industry
- Process control engineering
 - Chemical industry
 - Drying and processing systems in the pharmaceutical, food, and foodstuffs industries
 - Heat treatment and extraction plants used in plastics processing
- Flow measurements in ventilation, heating, and air-conditioning systems in both industry and agriculture

Certification

The measuring system complies with the requirements defined in the following standards:

DIN EN 15267-1:2009, DIN EN 15267-2:2009, DIN EN 15267-3:2008, DIN EN 14181:2004 and DIN EN ISO 16911-2.

The measuring system is suitable for use in plants requiring approval (13th BImSchV, 17th BImSchV, 30th BImSchV, TI Air) as well as plants of the 27th BImSchV.

2.2 System overview and functional principle

2.2.1 System overview

The measuring system comprises the following components:

- FLSE100 sender/receiver unit
For transmitting and receiving ultrasonic pulses, signal processing and controlling the system functions
- Flange with tube
For mounting the sender/receiver units on the gas duct
- MCU control unit
For control, evaluation and output of the data of the sensors connected via RS485 interface
- Connection cables
For signal transmission between the sender/receiver units and control unit
- Junction box for connection cable
For connecting the connection cables
- Purge air unit accessory
For using purged sender/receiver units to keep the ultrasonic transducers clean and cool at high gas temperatures
- Cooling air unit accessory
For using internally cooled sender/receiver units to keep the ultrasonic transducers cool at high gas temperatures
- Measuring tube option
Tube piece with flanges, preassembled for installation in an existing pipeline; with flanges with tube to fit the sender/receiver units

Fig. 1

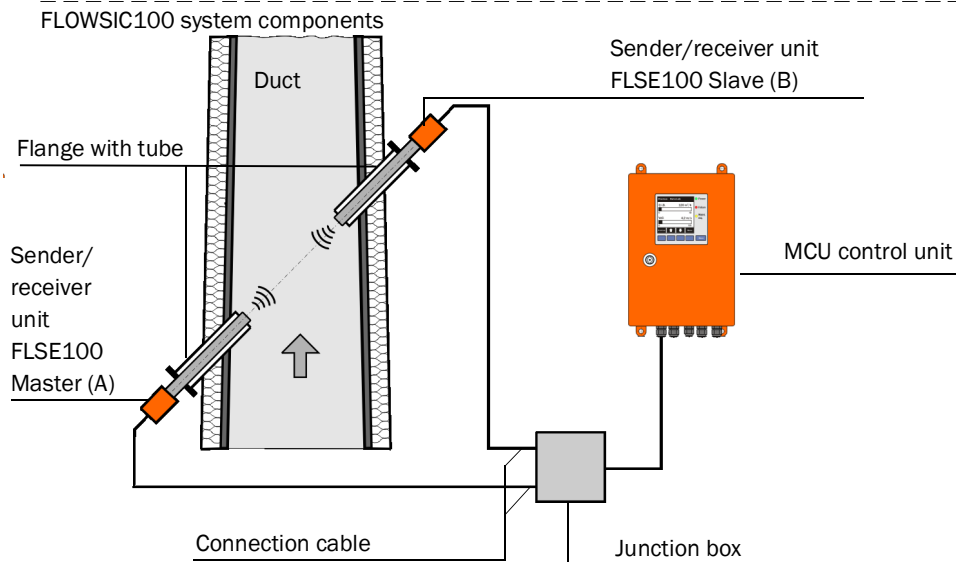

- Cooling air control option for device types M-AC and H-AC
Used to control the cooling air supply for sender/receiver units with internal cooling by switching the cooling air blower on and off automatically depending on the transducer temperature.
- Emergency air supply option for sender/receiver units with internal cooling (FLSE100-MAC and HAC)
Set for connecting and operating a temporary emergency air supply of instrument air (to be provided by customer) for sender/receiver units with internal cooling.
- Emergency air supply option for externally purged sender/receiver units (FLSE100-PM, PH, PH-S)

Set for connecting and operating a temporary emergency air supply of instrument air (to be provided by customer) for externally purged sender/receiver units.

2.2.2 Communication between sender/receiver units and control unit

Standard version

The two sender/receiver units work as master and slave. The master FLSE has a second interface to be able to completely separate communication to the slave FLSE and to the MCU. The master triggers the slave and controls measurement. The MCU can request the measured values from the master units independently of the measuring cycle (asynchronous).

For the cabling, the junction box used to separate the interfaces has to be installed on the master FLSE. The junction box is optional for FLOWSIC100 types PR and S (for longer cable lengths).

Fig. 2 Standard version (1 sensor pair)

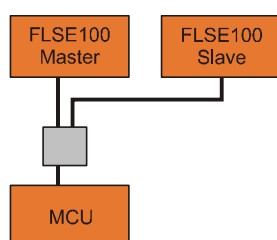

Bus version with several measuring systems connected

Fig. 3 Bus connection FLSE100 - MCU (2 sensor pairs)

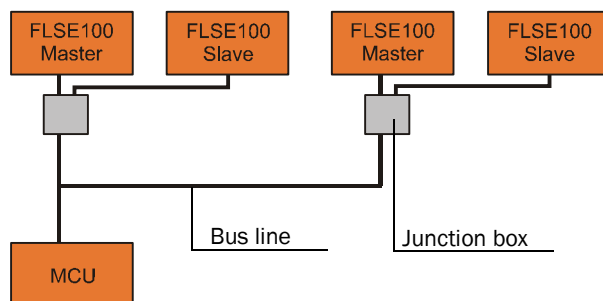

With the bus version, two autonomous measuring paths (2 x 2 FLSE100) can be connected to a control unit MCU for 2-path-measurement. The MCU computes both measuring paths to one measuring result.



- For bus wiring, the set termination set at the factory must be deactivated in those system components not at the line end (see Service Manual Section 3.1).
- Other sensor types (e.g. sensor for dust measurement) can also be connected to the MCU.

2.2.3 Functional principle

The FLOWSIC100 gas flow rate measuring devices operate according to the principle of ultrasonic transit time difference measurement. Sender/receiver units are mounted on both sides of a duct/pipeline at a certain angle to the gas flow (→ Fig. 4).

These sender/receiver units contain piezoelectric ultrasonic transducers that function alternately as senders and receivers. The sound pulses are emitted at an angle α to the flow direction of the gas. Depending on angle α and gas flow rate v , the transit time of the respective sound direction varies as a result of certain “acceleration and braking effects” (formulas 2.1 and 2.2). The higher the gas flow rate and the smaller the angle to the flow direction are, the higher the difference in the transit times of the sound pulses.

Gas flow rate v is calculated from the difference between both transit times, independent of the sound velocity value. Therefore changes in the sound velocity caused by pressure or temperature fluctuations do not affect the calculated gas flow rate with this method of measurement.

Fig. 4

Functional principle of the FLOWSIC100

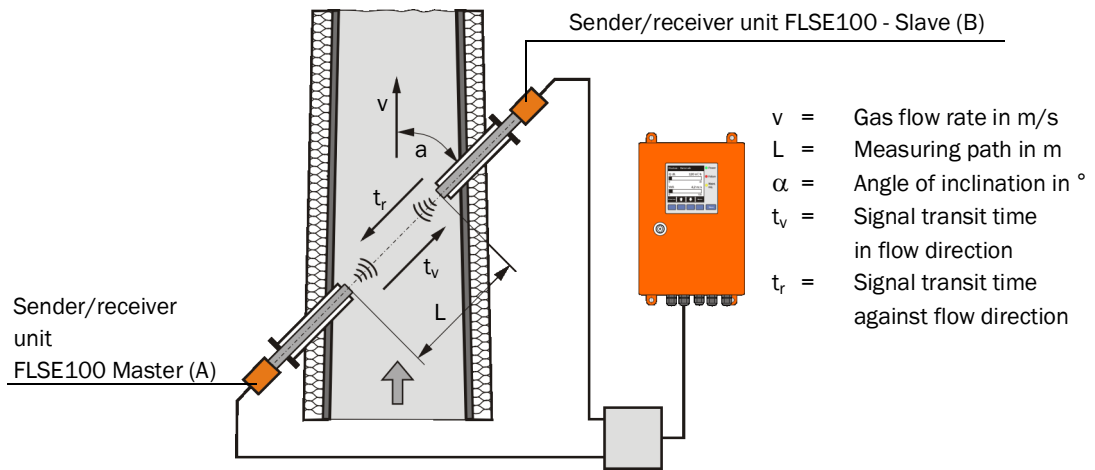

Calculating the gas flow rate

Measuring path L is equal to the active measuring path, that is, the area through which the gas flows. Given measuring path L , sound velocity c , and angle of inclination α between the sound and flow direction, the sound transit time in the direction of the gas flow (forward direction) when the signal is transmitted can be expressed as:

$$t_v = \frac{L}{c + v \cdot \cos \alpha} \quad (2.1)$$

Against the gas flow (backward direction):

$$t_r = \frac{L}{c - v \cdot \cos \alpha} \quad (2.2)$$

After the resolution to v :

$$v = \frac{L}{2 \cdot \cos \alpha} \cdot \left(\frac{1}{t_v} - \frac{1}{t_r} \right) \quad (2.3)$$

Apart from the two measured transit times, this relation only contains the active measuring path and the angle of inclination as constants.

Sound velocity

Sound velocity c can be calculated by resolving formulas 2.1 and 2.2.

$$(2.4) \quad c = \frac{L}{2} \cdot \left(\frac{t_v + t_r}{t_v \cdot t_r} \right)$$

Based on the dependencies in formulas 2.5 and 2.7, the sound velocity can be used to determine the gas temperature and for diagnosis purposes.

$$(2.5) \quad c = c_0 \cdot \sqrt{1 + \frac{\vartheta}{273 \text{ °C}}}$$

Calculating the gas temperature

Since the sound velocity is dependent on the temperature, the gas temperature can also be calculated from the transit times (by resolving formulas 2.4 and 2.5 to derive ϑ).

$$(2.6) \quad \vartheta = 273 \text{ °C} \cdot \left(\frac{L^2}{4 \cdot c_0^2} \left(\frac{t_v + t_r}{t_v \cdot t_r} \right)^2 - 1 \right)$$

Formula 2.6 shows that, in addition to the measured transit times, the square of the values of L and the standard velocity are included in the calculation.



This means precise temperature measurement is only possible when the gas composition is constant, measuring path L has been measured extremely accurately and a calibration has been carried out (see Section → p. 151, 4.3.6).

Determining the volume flow

The volume flow in operating state is computed using the geometric constants of the duct. The process parameters pressure, temperature and moisture content are required to calculate the volume flow in the standard state. A detailed description is provided in Section § 2.4, page 44.

Path compensation

When the FLOWSIC100 is operated with a 2-path configuration, the device runs with an integrated algorithm for automatic “path compensation”.

During trouble-free operation, gas and sound velocity relations between both measuring paths are recorded and saved. Should one path then fail, the system can replace invalid measured values from the failed path with theoretical values based on the “learned” path relations. The system signals “Maintenance request” status at the same time.

This means a single path can be compensated temporarily and measurement continued with a slightly higher uncertainty until the malfunction has been cleared.

2.3 System components

2.3.1 FLSE100 sender/receiver unit

The sender/receiver unit consists of the electronics, connector, duct probe, and transducer modules. These modules are available in different versions that can be combined on the basis of the relevant application data to produce the optimum configuration for the application in question.

Fig. 5 Schematic diagram with modules of the sender/receiver unit and flange with tube

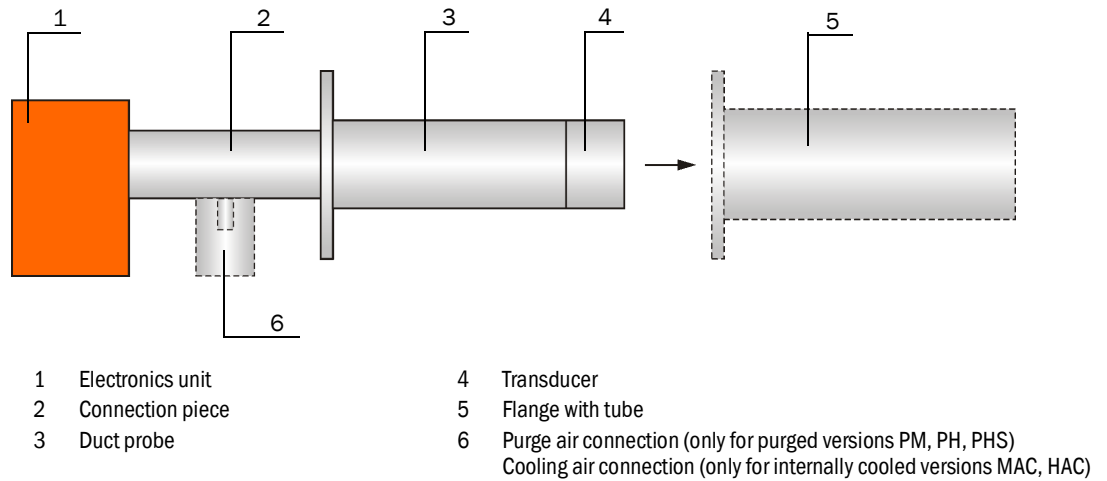

The modules are selected on the basis of the following criteria:

- Gas temperature
Decision whether the sender/receiver unit must or can be used with or without internal cooling air so that the duct probe can be selected with regard to type of material (steel, titanium) and transducer type (with/without internal cooling)
- Gas composition (corrosive / slightly corrosive or not corrosive)
Selection of the duct probe and transducers on the basis of their resistance to corrosion (probe made from stainless steel / titanium, transducers made from titanium / hastelloy)
- Duct diameter, sound dampening, dust content
Selection of the transducers on the basis of the required transmitter power (medium power / high power)
- Dust properties
Decision whether purged sender/receiver units need to be used (prevention of contamination with very sticky dust).
- Wall and insulation thickness of the gas duct
Selection of the duct probe and flange with tube according to the nominal length (graded standard lengths). Other lengths can be supplied on request.
- Assembly type
On two sides, each with a sender/receiver unit on the opposite duct walls, or on one side with one sender/receiver unit (as measuring probe version)
- Flange size
Selection of small or large flange dimensions (pitch diameter of the fixing holes 75 mm, 100 mm or 114 mm)
- Internal duct pressure
Pressure resistant versions must be used with pressures above 100 mbar (see OI FLOWSIC100 PROCESS)
- Certification requirements
Selection after performance tests for emission measuring.

The various configuration options are identified by a type key structured as follows:

Type key sender/receiver unit:

FLSE100-XXX (X) XX XX XX

Purge air supply yes/no _____

- P: Purged

Ultrasonic transducer _____

- M: Medium power

- H: High power

- S: Low power with small dimensions
(Small size)

- PR: Low power with small dimensions
and measuring probe version

Signal transmission _____

- D: Digital (identification for FLSE100-SD only)

- A: Analog (identification for FLSE100-SA only)

- Empty: Digital

Identification _____

- Empty: No special features

- AC: Internal cooling of ultrasonic transducer

Nominal length of duct probe _____

- 12: 125 mm

- 20: 200 mm

- 35: 350 mm

- 55: 550 mm

- 75: 750 mm

Duct probe material _____

- SS: 1.4571 (stainless steel)

- TI: Titanium

- HS: Hastelloy

Transducer material _____

- TI: Titanium

- HS: Hastelloy

Example:

FLSE100-M 35SSTI

Medium transducer power _____









Duct probe nominal length 350 mm _____

Duct probe material 1.4571 _____

Transducer made of titanium _____

The possible versions, areas of application, configurations, and characteristics are listed in the following Tables.

Basic versions

Type FLSE100	Description	Number of FLSE100 per system
M 	<ul style="list-style-type: none"> ● Not purged ● Medium power ● Digital signal transmission to control unit 	2
H 	<ul style="list-style-type: none"> ● Not purged ● High power ● Digital signal transmission to control unit 	2
PR 	<ul style="list-style-type: none"> ● Not purged ● With two transducers, small size and high frequency ● Version as measuring probe for installation on one duct side ● Digital signal transmission to control unit 	1
SA/SD 	<ul style="list-style-type: none"> ● Not purged ● With one small size and high frequency transducer ● Digital signal transmission to control unit (SD) 	1 each
MAC 	<ul style="list-style-type: none"> ● Internally air cooled ● Medium power ● Digital signal transmission to control unit 	2
HAC 	<ul style="list-style-type: none"> ● Internally air cooled ● High power ● Digital signal transmission to control unit 	2
PM 	<ul style="list-style-type: none"> ● Purged ● Medium power ● Digital signal transmission to control unit 	2
PH 	<ul style="list-style-type: none"> ● Purged ● High power ● Digital signal transmission to control unit 	2
PHS 	<ul style="list-style-type: none"> ● Purged ● Very high power ● Digital signal transmission to control unit 	2

Application range

Type FLSE100	Material Duct probe	Material Transducer	Max. gas temperature [°C]	Active meas. distance ¹⁾ [m]	Duct/pipe diameter [m]	
M	SS, TI	TI	260	0.2 - 4	0.15 - 3.4	
	Hastelloy			0.2 - 2	0.15 - 1.7	
H	SS, TI	TI		2 - 15	1.4 - 13	
	Hastelloy			1.5 - 2.5 ²⁾	1.1 - 2.5 ³⁾	
	Hastelloy			2 - 5	1.4 - 4.3	
PR	SS, TI	TI		0.27 - 0.28	> 0.40	
SA/SD	SS			150	0.2 - 2	0.15 - 1.7
MAC	SS, TI			450	0.2 - 4	0.15 - 3.4
HAC					2 - 13	1.4 - 11.3
PM	SS			450	1.5 - 2.5 ²⁾	1.1 - 2.5 ³⁾
PH	SS, TI		0.5 - 3		0.35 - 2.5	
			1 - 10		0.7 - 8.7	
PHS	SS		1 - 2 ²⁾		0.7 - 2 ³⁾	
			2 - 13	1.4 - 11.3		
				1.5 - 2.5 ²⁾	1.1 - 2.5 ³⁾	

1): The maximum possible measuring path depends on the dust content, gas temperature, and gas composition

2): For extremely high dust concentrations up to max. 100 g/m³

3): For installation across secant (→ p. 57, 3.1.3)

Duct probe configuration options

Type FLSE100	Duct probe							
	Nominal length in mm					Material		
	125	200	350	550	750	SS	TI	HS
M		x	x	x		x	x	x
H		x	x	x	x	x	x	x
PR			x	x	x	x	x	
SA/SD	x	x	x			x		
MAC			x	x		x	x	
HAC			x	x		x	x	
PM		x	x	x	x	x		
PH		x	x	x	x	x	x	
PHS			x	x	x	x		

2.3.1.1

Standard sender/receiver units

A special transducer design makes it possible to use these sender/receiver units without cooling by external purge air even with higher gas temperatures. A purge air unit is therefore not necessary. The advantages are:

- Lower expense for mounting and installation
- Easier maintenance
- Lower operating costs.

For these reasons, standard sender/receiver units should be used where possible.



- The types FLSE100-M, H and PR are intended for use with gas temperatures up to max. 260 °C. The types FLSE100-SA and SD are intended for use up to 150 °C.
- The measuring system FLOWSIC100 S contains one sender/receiver unit FLSE100-SA and FLSE100-SD and one connection cable between the sender/receiver units.
- The type FLSE100-SA has no electronics unit. Communication to the FLSE100-SD as master (which communicates with the MCU control unit) runs via an analog connection cable (fixed length: 3m). Install one FLSE100-SA and one FLSE100-SD per sampling point (1-path configuration).
- Fit the sender/receiver units at an angle of 60° to the flow direction for dust concentrations > 1 g/m³ (only applicable for FLSE100-H, H-AC, PH and PH-S). The downstream sender/receiver unit (B in → p. 15, Fig. 4) has to be equipped with an impact protector.

The following differences exist in addition to the possible versions:

Type FLSE	Transducer and duct probe
M	Nominal diameter 35 mm
H	Nominal diameter 60 mm
PR	Measuring probe version (2 transducers)
SA, SD	Duct probe \varnothing 35 mm, transducer 15 mm

Fig. 6

FLSE100-M

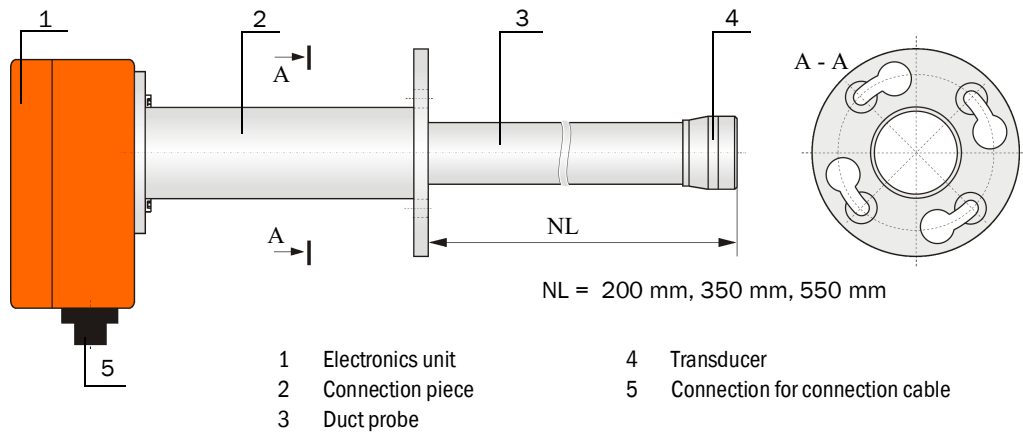

The type FLSE100-M is also available with other flanges on request
 (→ p. 169, 6.3.1).

Fig. 7

FLSE100-H

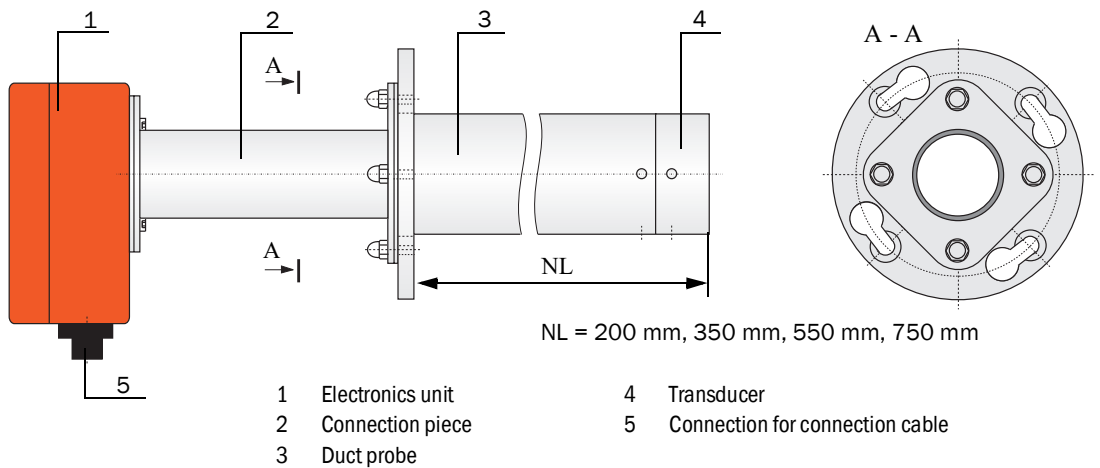

Fig. 8 FLSE100-PR

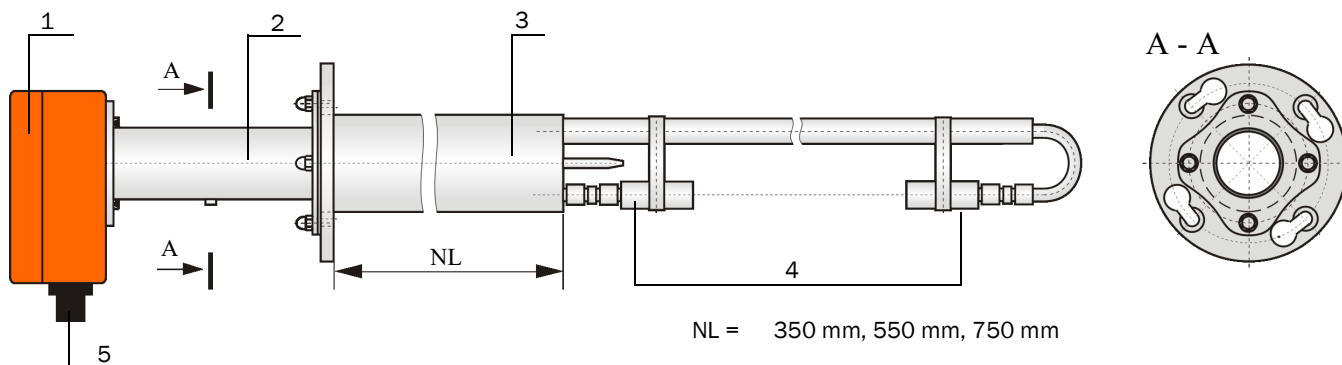

Fig. 9 FLSE100-SA

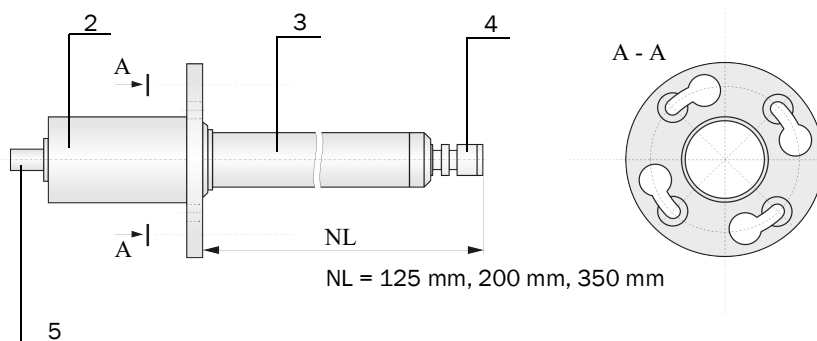
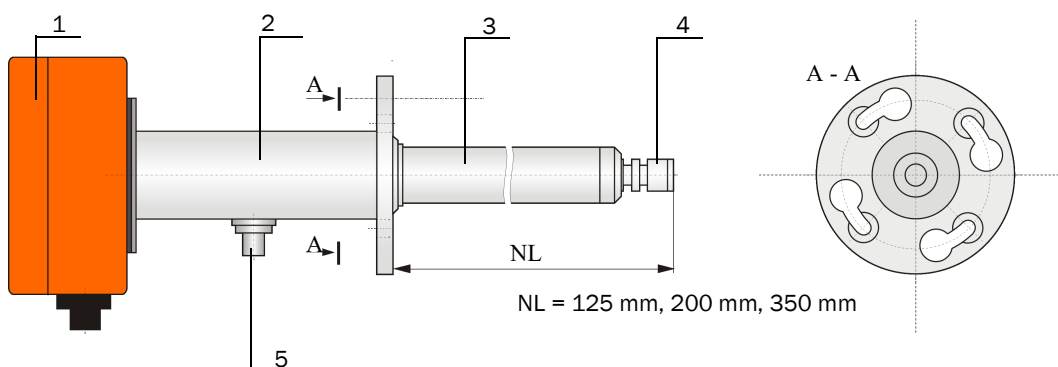

Fig. 10 FLSE100-SD



- | | | | |
|---|------------------|---|---------------------------------|
| 1 | Electronics unit | 4 | Transducer |
| 2 | Connection piece | 5 | Connection for connection cable |
| 3 | Duct probe | | |

Subject to change without notice

2.3.1.2 **Sender/receiver units with internal cooling**

The types FLSE100-MAC and HAC can be used for gas temperatures up to maximum 450 °C when fitted with internal cooling for the ultrasonic transducers. A control unit with integrated filter and blower supplies the cooling air (→ p. 29, 2.3.3).

The advantages over the purged versions are:

- Lower costs for installation and operation.
- No flow of cooling air into the measured medium, therefore no direct influence on gas flow and flow rate
- Lower risk of dropping below the dew point with condensate on the probe head.



Fit the sender/receiver units at an angle of 60° to the flow direction for dust concentrations > 1 g/m³ (only applicable for FLSE100-HAC). The downstream sender/receiver unit (B in Fig. 4, page 15) must be equipped with an impact protector.



NOTICE:

Wet or sticky dust can cause strong contamination of the transducer and disrupt the measuring function. In this case, the cooling air control option, Part No. 2050814, should be used on device versions with internal cooling (M-AC and H-AC). Use an external device version when necessary.

The following differences exist in addition to the possible versions:

Type FLSE100	Transducer and duct probe
MAC	Nominal diameter 35 mm
HAC	Nominal diameter 60 mm

Fig. 11

FLSE100-MAC

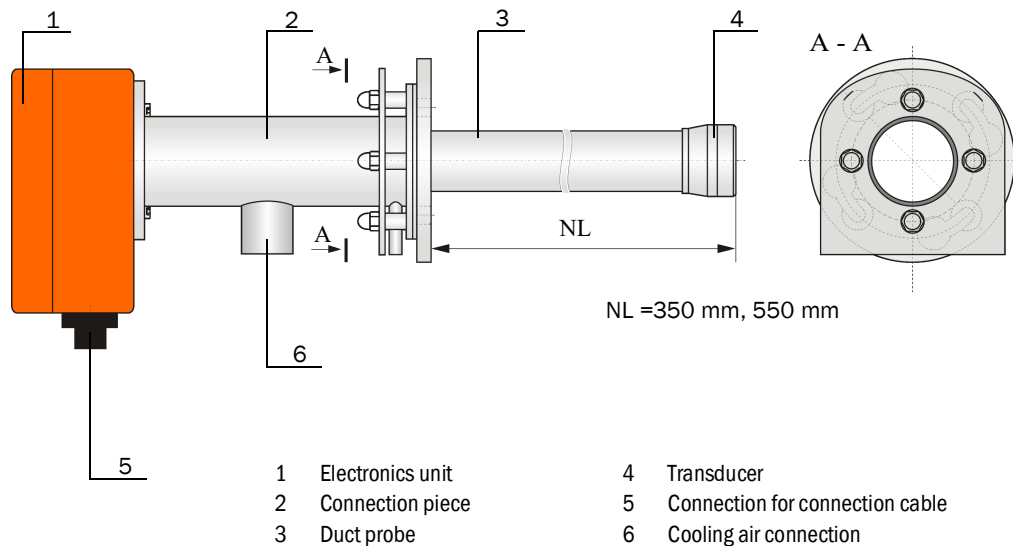

The type FLSE100-MAC is also available with other flanges on request (→ p. 169, 6.3.1).

Subject to change without notice

Fig. 12

FLSE100-HAC

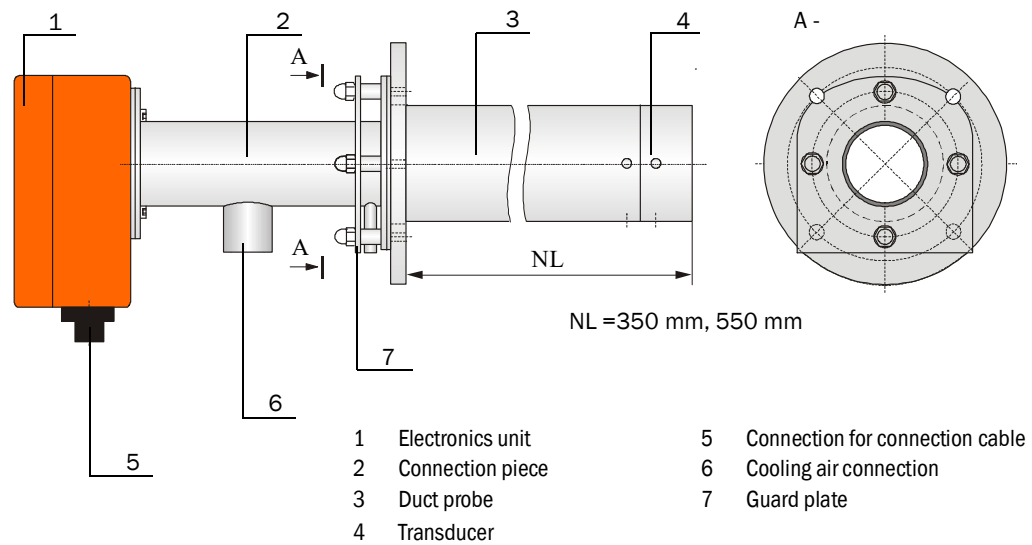

Functional principle of internal cooling (FLSE100-MAC and FLSE100-HAC)



CAUTION: Risk of burns through escaping hot cooling air

The cooling air is heated by the gas temperature in the duct and escapes at the sender/receiver unit into the environment. The temperature of the heated cooling air depends on the gas temperature and the cooling air flow.

There might be risk of burns through hot cooling air!

► Provide suitable protective measures.

The cooling air is fed into the sender/receiver unit via the cooling air connection. In the sender/receiver unit, the cooling air is internally led to the transducer. Thus, the transducer is protected against overheating. The heated cooling air escapes at the flange of the sender/receiver unit into the environment.

Fig. 13

Schematic diagram

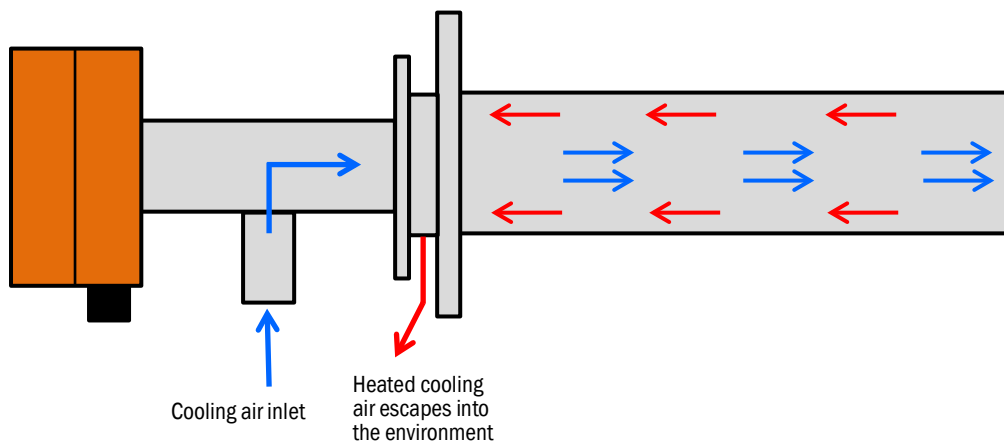

2.3.1.3 Purged sender/receiver units

Fig. 14 FLSE100-PM, PH, PHS

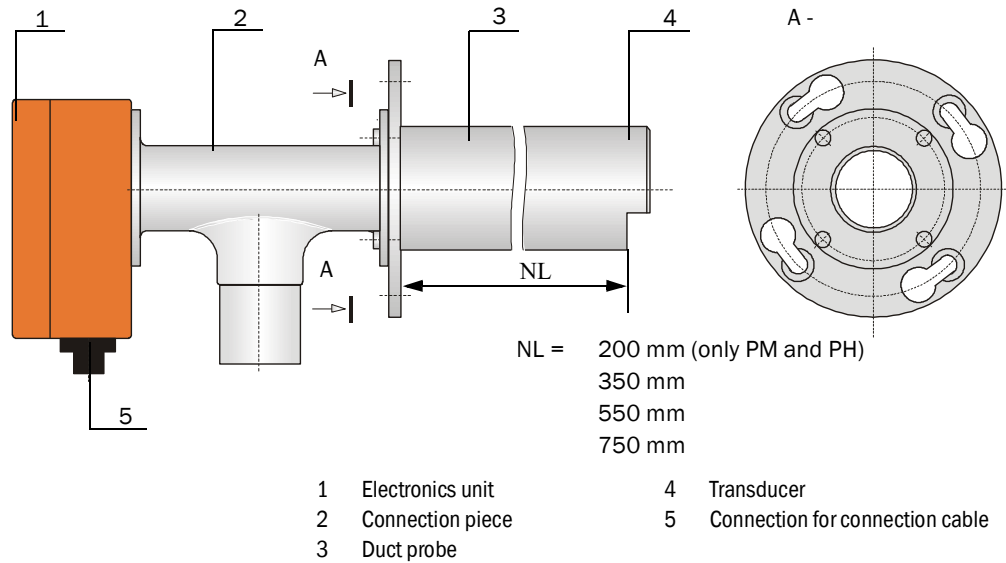

These sender/receiver units are intended only for use with wet and sticky dust when the transducer surface is in high danger of contamination. Purge air is supplied by a purge air unit to keep the active transducer surface clean and therefore protect against contamination (→ p. 43, 2.3.10). The purge air flow is optimized to maximize the directivity of the ultrasound beam.

An integrated temperature sensor records the transducer temperature which can then be displayed in SOPAS ET.



See the Application Range Table on page 21 for limitations of use



For dust concentrations $> 1 \text{ g/m}^3$, install the sender/receiver units at an angle of 60° to the flow direction (only applicable for FLSE100-PH and PHS). The downstream sender/receiver unit (B in → p. 15, Fig. 4) has to be equipped with an impact protector.



At low gas temperatures, the purge air supply can cause the temperature to drop below the dew point. To minimize the possible corrosion on the probe head (for example, due to acid formation with corrosive gas compositions), duct probes with a nominal length greater than that actually required for the flanges with tube must be selected for temperatures between 150°C and 200°C (for example, if the nominal length of the flange with tube is 350 mm → a duct probe with a nominal length of 550 mm should be used). The purge air is then heated by the gas temperature in the probe tube which minimizes temperature drops below the dew point.

Fig. 15 Using sender/receiver units with a nominal length greater than the flange with tube

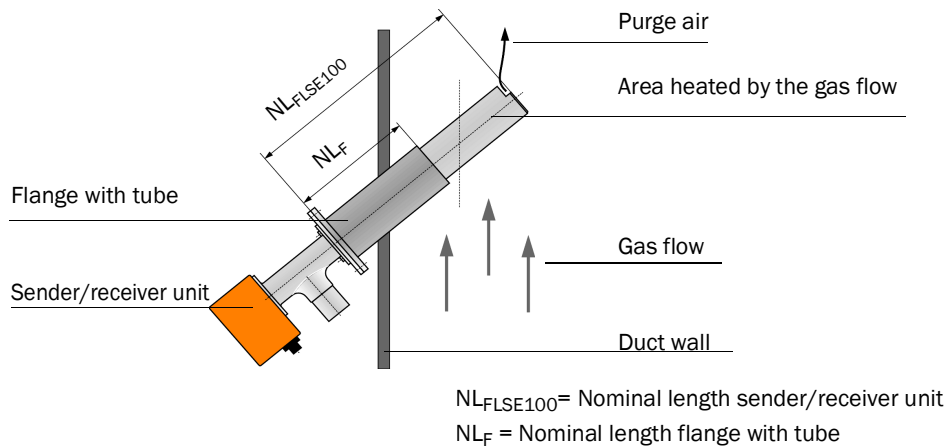

2.3.2 Flange with tube

The sender/receiver units are mounted in flanges with tube available in graded nominal lengths, different steel types and pitch diameters.

Selection of a flange with tube depends on:

- Installation angle and wall and insulation thickness of duct wall
→ Determining the nominal length (Assembly and Installation Chapter, → p. 49)
- Type of sender/receiver unit
→ Pitch diameter of flange, pipe diameter
- Duct material
→ Steel type



If required, the flanges with tube can also be delivered in advance.

Fig. 16 Flange with tube

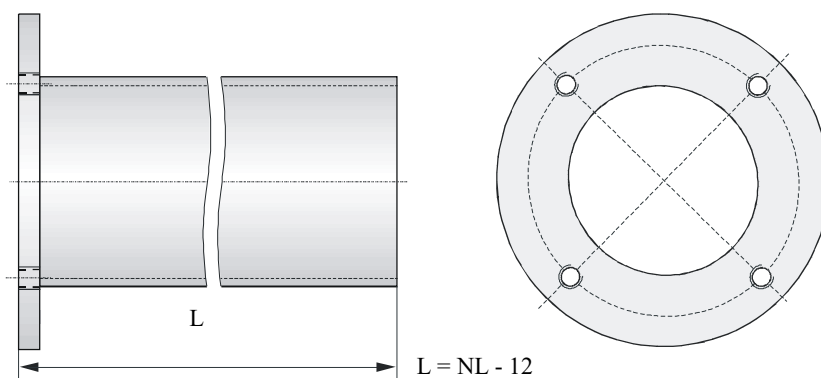

Type FLSE100	Nominal length in mm	Material
S	125	St37, V4A (others on request)
S, M, PM, PH	200	
S, M, MAC, H, HAC, PR, PM, PH, PHS	350	
M, MAC, H, HAC, PR, PM, PH, PHS,	550	
H, PR, PM, PH, PHS	750	

2.3.3 Weatherproof cover

The weatherproof cover protects the electronics of the sender/receiver unit against sunlight and rain.

Fig. 17 Weatherproof cover with holder

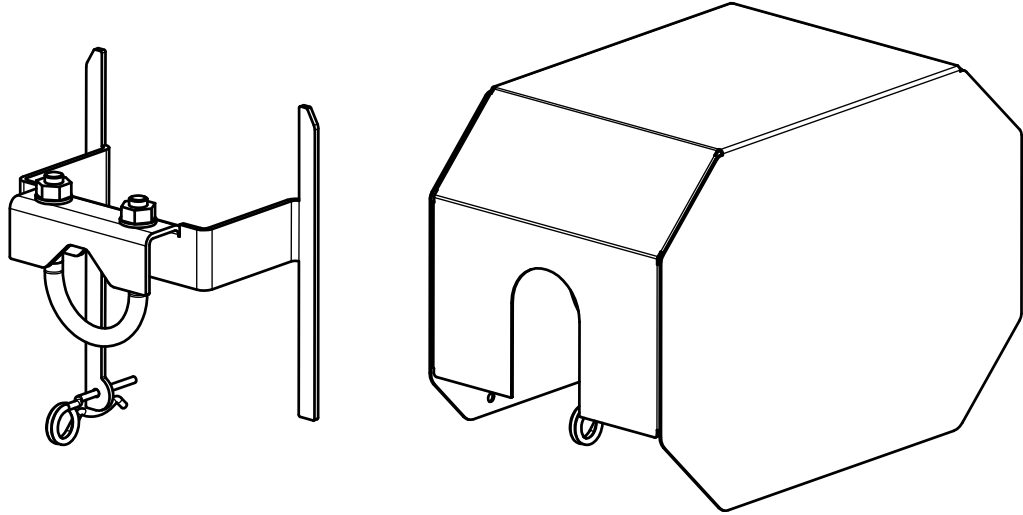

2.3.4 MCU control unit

The control unit has the following functions:

- Control of data transfer and processing the data from the sender/receiver units connected via RS485 interface
- Signal output via analog outputs (measured value) and relay outputs (device status)
- Signal input via analog and digital inputs
- Voltage supply for the connected sender/receiver units
- Communication with host control systems via optional modules

System and device parameters can be set easily and conveniently via a USB interface using a laptop and the user-friendly SOPAS ET operating software. The parameters are stored reliably even in the case of a power failure.

The control unit is usually installed in a steel plate housing. It is available as 19" rack as an option.

Versions

1 Control unit without cooling air supply

This control unit serves for connecting sender/receiver units FLSE100-M, H, PR, S, PM, PH and PHS (optional for FLSE100-MAC and HAC).

Fig. 18

Control unit MCU with options

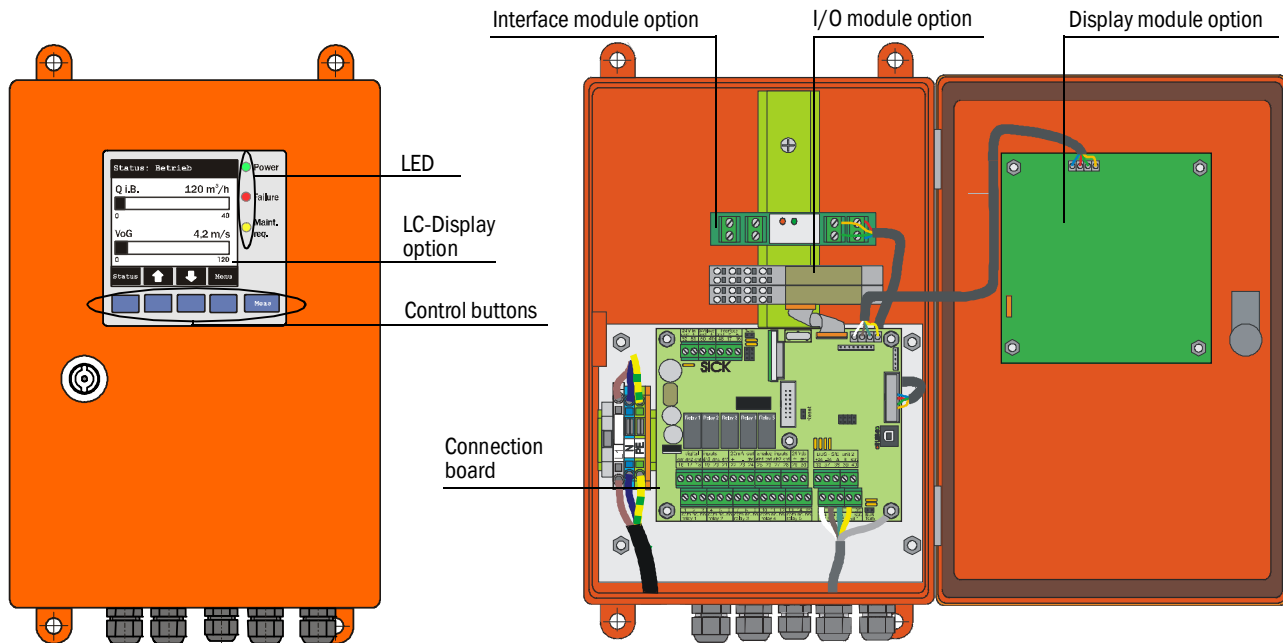

2 Control unit with integrated cooling air supply (only for types M-AC and H-AC)

This version is additionally equipped with a purge air blower, air filter and purge air connection for connecting DN 25 purge air hoses (must be ordered separately → p. 171, Fig. 140) for sender/receiver units with internal cooling (types FLSE100-MAC and HAC).

Fig. 19 Control unit with integrated cooling air supply

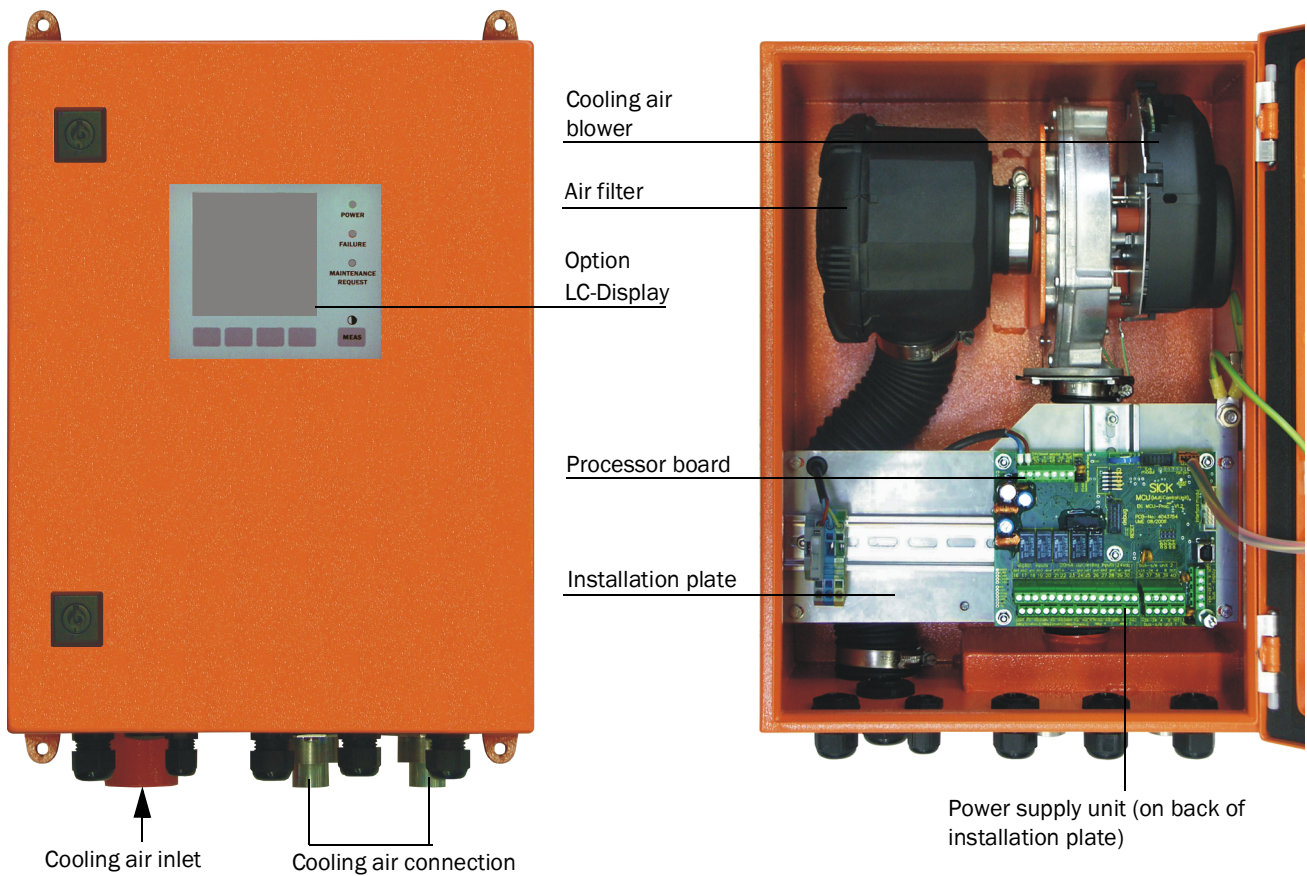

Standard interfaces

Analog output	Analog inputs	Relay outputs	Digital inputs	Communication
1 output 0/2/4 ... 22 mA (active) for selectable output of measured variables: ● Velocity ● Volume flow act. ● Volume flow std. ● Temperature ● Resolution 12 bits	2 inputs 0 ... 20 mA (standard; without electric isolation) or 0 ... 5/10 V for selectable input of optional entry of calculation variables (temperature, pressure, moisture) resolution 12 bit	5 changeover contacts (48 V 1 A) to output status signals: ● Operation/ malfunction ● Maintenance ● Check cycle ● Warning ● Limit value	2 inputs for connecting potential-free contacts (e.g. for connecting a maintenance switch or triggering a check cycle)	● USB 1.1 and RS232 (on terminals) for measured value inquiries, setting parameters and firmware updates ● RS485 to connect sensors

Control unit MCU in 19" enclosure with options

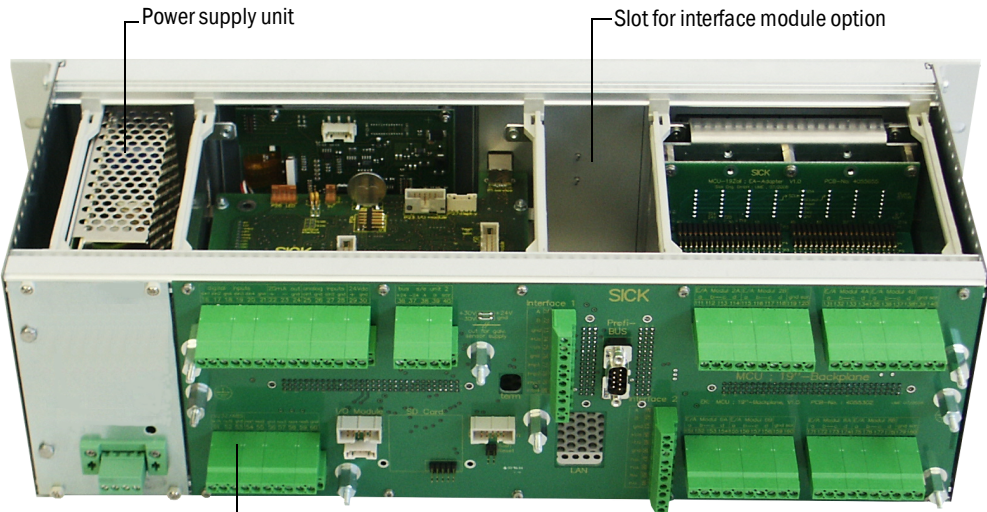
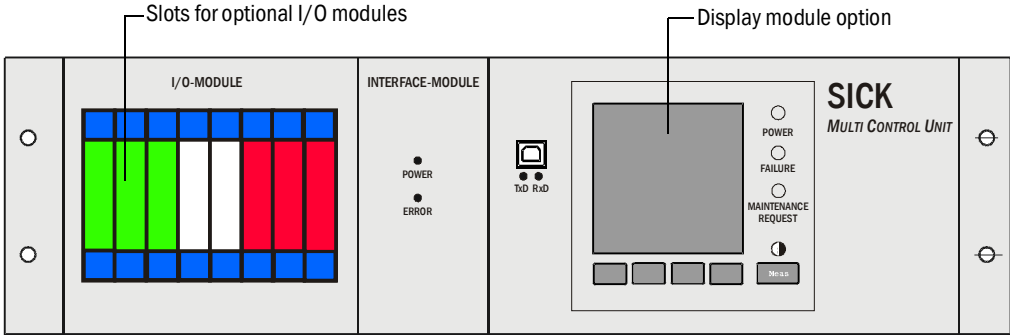

Backplane with terminal connections for wiring by customer

Subject to change without notice

Block Diagram

Fig. 20 MCU block circuit diagram

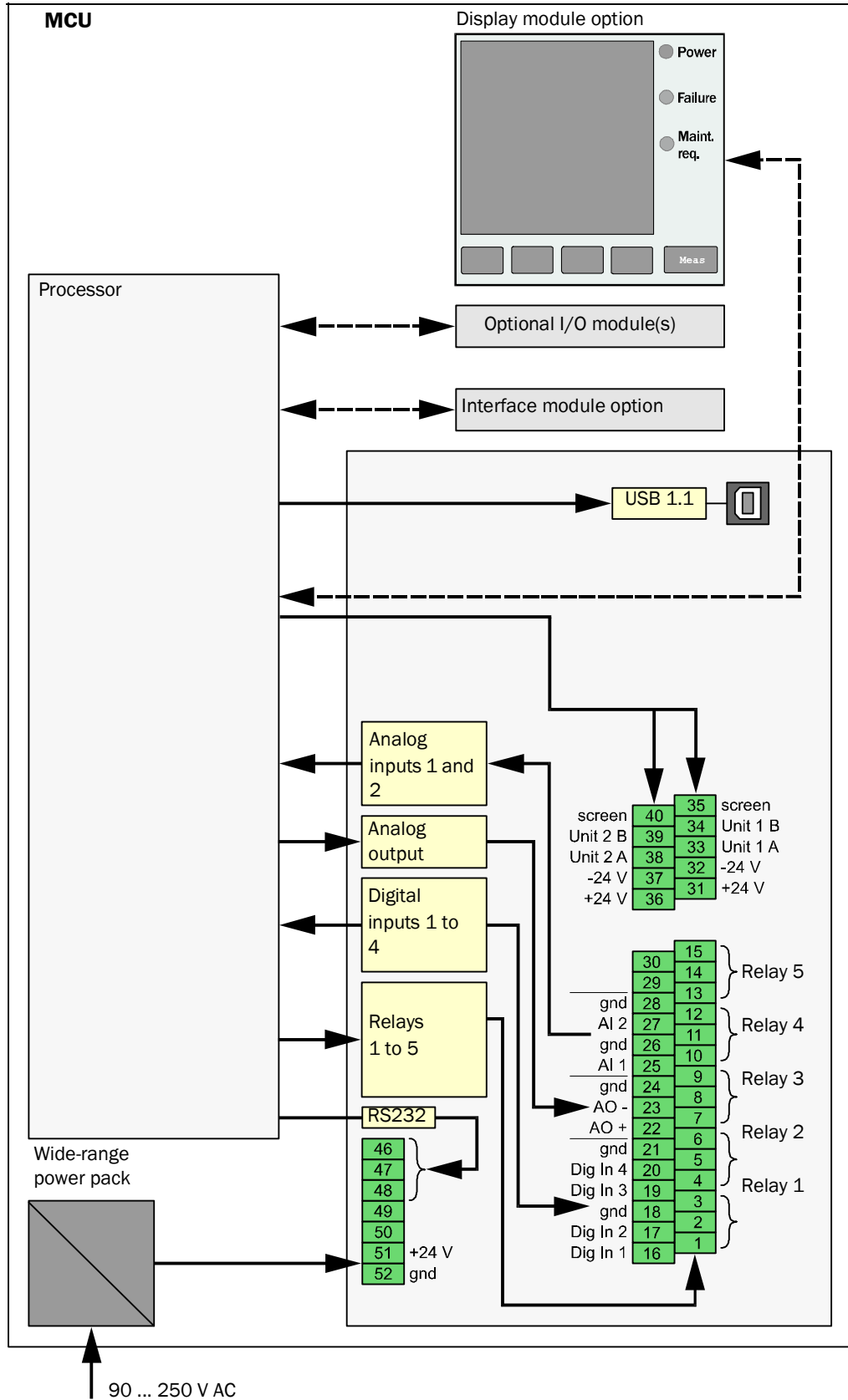

Subject to change without notice

Options

Using the following options, the functionality of the MCU can be extended considerably:

1 Display module

Module to display measured values and status information of the connected sensors using control buttons (capacitive sensors). The integration of this module into already delivered control units can only be done by the supplier.

Displays

Type		Display
LED	Power (green)	Power supply
	Failure (red)	Functional failure
	Maint. request (yellow)	Maintenance request
LC-Display	Graphical display (main display)	Two of a variety of possible measured values: Volume flow in operating state (Q a.c.) Volume flow in standard state (Q std.) Gas flow rate (VoG) Sound velocity (SoS) Acoustic temperature (T ac) Transducer temperature A (T A) Transducer temperature B (T B) Signal to noise ratio A (SNR A) Signal to noise ratio B (SNR B) Mass flow
	Text display	6 possible measured values (see graphical display)

The measurement screen displays bar graphs of two selectable main measured values of a connected sensor or of the MCU. Alternatively, up to 8 individual measured values of a sensor can be displayed (switching with button "Meas").

Fig. 21

LC-Display in graphical display (left) and in text display (right)

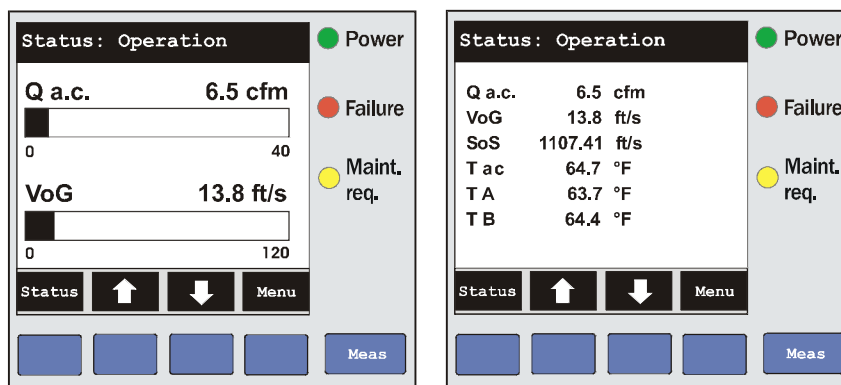

If a limit value is exceeded, the display alternates between the measured value and an alarm message.

Control buttons

Button	Function
Meas	<ul style="list-style-type: none"> ● Selects the single measured value to be displayed ● Toggles between text display and graphical display ● Displays the contrast settings (after 2.5 s)
Arrows	<ul style="list-style-type: none"> ● Selects next/previous measured value screen
Status	<ul style="list-style-type: none"> ● Displays alarm or error messages
Menu	<ul style="list-style-type: none"> ● Display of main menu

The following functions are additionally available in the display module:

- Entering parameters for start-up
- Initiating a check cycle
- Switching to Maintenance mode.

2 I/O module

For installation on module carriers, communication via I²C bus, or in rack (MCU in 19" enclosure), selectable as:

- 2x analog output 0/4 ... 22 mA to output further measured variables (load 500 Ω)
- 2x analog input 0/4 ... 22 mA to read in values from external sensors



- One module carrier is necessary for each module (to insert on top hat rail). One module carrier has to be connected to the processor board with a special cable, other module carriers can be docked to it.
- Maximum for installation and use:
 - 2 optional AO modules
 - 1 optional AI module

3 Interface module

Modules to pass measured values, system status and service information to higher level control systems, optional for Profibus DP, Ethernet and Modbus, for insertion in slot (→ p. 36, Fig. 22).



Profibus DP-V0 for transfers via RS485 according to DIN 19245 Part 3 as well as IEC 6115

MCU processor board connections

Fig. 22 MCU processor board connections

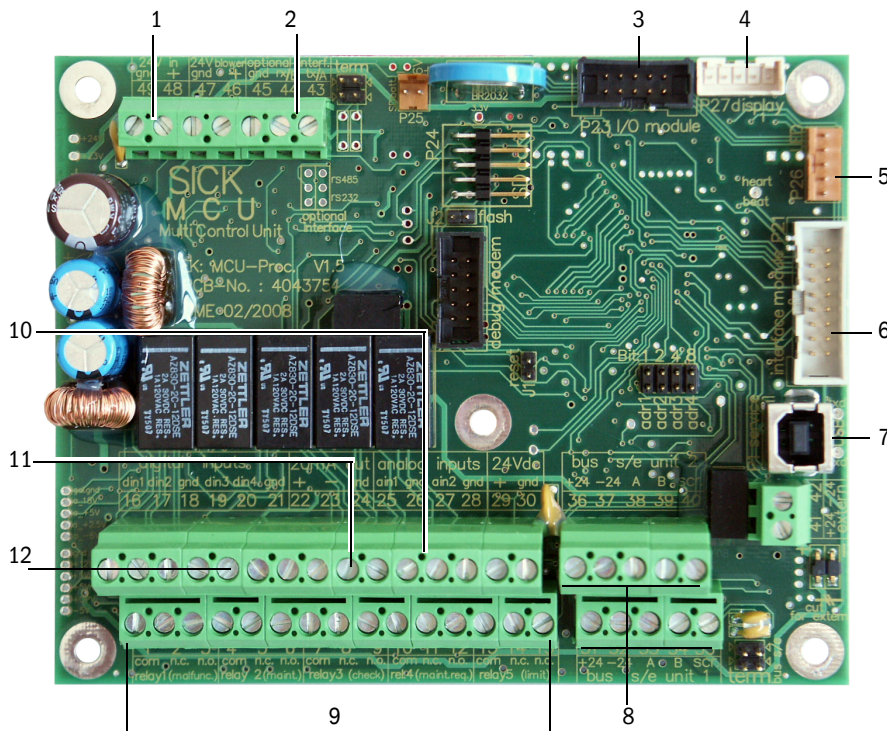

- 1 Supply voltage 24 V DC
- 2 RS232
- 3 Connection for I/O module option
- 4 Connection for display module
- 5 Connection for LEDs
- 6 Connection for interface module option
- 7 USB plug-in connector
- 8 Connections for sender/receiver units
- 9 Connections for relays 1 to 5
- 10 Connections for analog inputs 1 and 2
- 11 Connection for analog output
- 12 Connections for digital inputs 1 to 4 (digital inputs 3 and 4 not supported at present)

Type key MCU

The various configuration options are defined by the following type key:

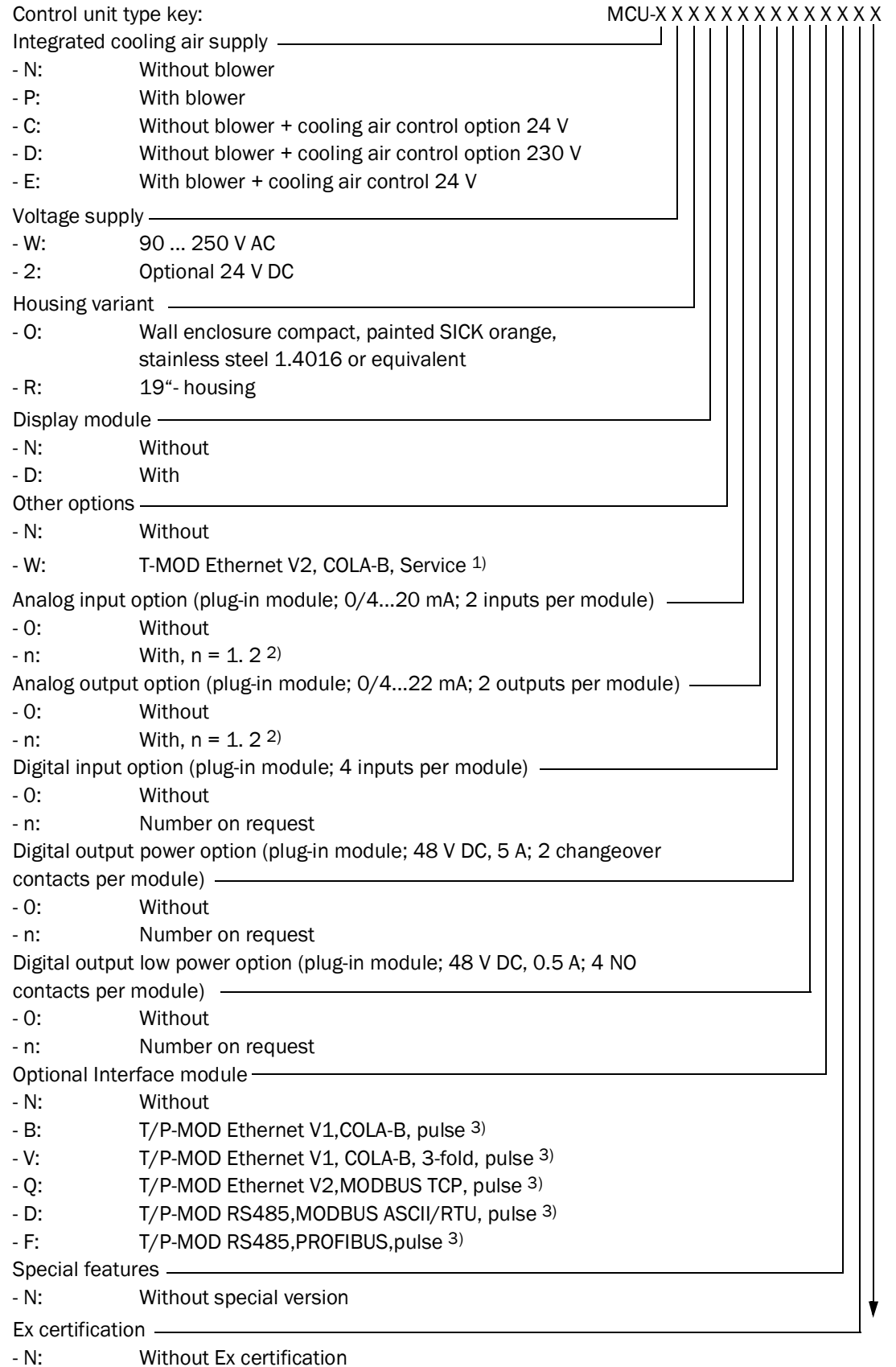

Subject to change without notice

Software _____
 - E: Emission

- 1): Only for MCU version with wall enclosure
- 2): Up to 4 analog modules on request
- 3): Pulse not available

Example:

MCU-NWODNO1000PNNE

Without cooling air supply _____

Wide-range power pack 90...250V AC _____

Wall enclosure SICK orange _____

With display module _____

Without other options _____

Without optional analog input module _____

With one optional analog output module _____

Without optional digital input module _____

Without optional digital output module, 2 changeover contacts _____

Without optional digital output module, 4 NO contacts _____

With optional interface module Profibus DP _____

Without special version _____

Without Ex certification _____

Software Emission _____

2.3.5

Connection cable

The connection cables master (Master FLSE100) and slave (Slave FLSE100) are used to connect the sender/receiver units with the control unit MCU. Both cables are available in different lengths. The connection cable master is marked with a red marker behind the cable box.

Fig. 23

Connection cable

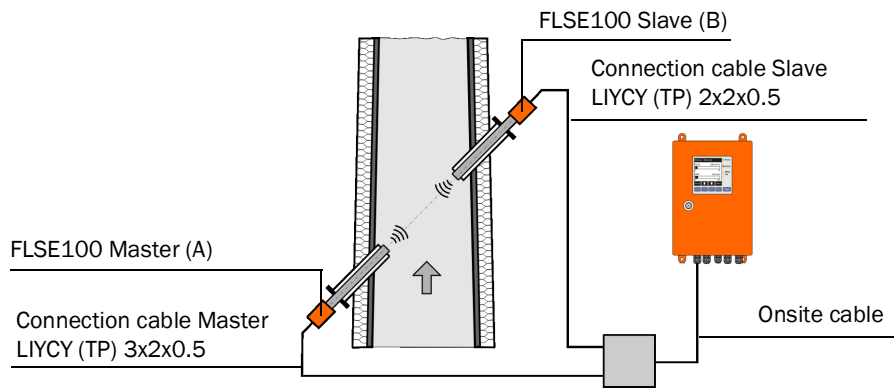

Cables provided onsite must fulfill the following requirements (see also page 97, § 3.3.6):

- Lead/lead operational capacity less than 110 pF/m
- Min. lead cross-section 0.5 mm² (AWG20).

We recommend cable type UNITRONIC Li2YCYv(TP) 2x2x0.5 mm² with reinforced outer sheath (from Lappkabel).

The total length of the cable between junction box and MCU (onsite cable) can be up to 1000 m.



When connecting bus versions with several sensors (→ p. 14, Fig. 3), the maximum cable length is reduced as follows depending on the number of sampling points connected:

- Cable length with + 1 sampling point = 1000 m
- Cable length with + 2 sampling points = 500 m

2.3.6 Purge air unit accessory

The purge air unit is used to supply the sender/receiver units of the types FLSE100-PM, PH and PHS with clean purged air.

Fig. 24 Purge air unit SLV 1

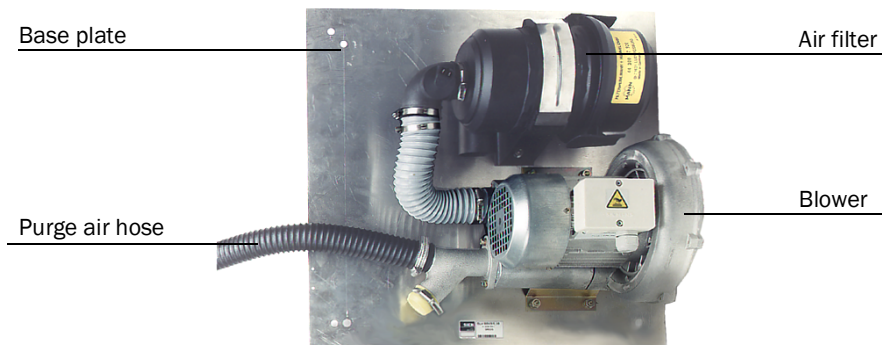

Depending on the internal duct pressure, use additional reducers (optional purge air reducer set) or a purge air unit with a more powerful blower as shown in the following Table.

Internal duct pressure (mbar)	Reducer	Blower type
-100 ... -20	40/7	2BH1300
-20 ... -10	40/10	
-10 ... +30	-	2BH1400
+30 ... +100	-	

2.3.7 Option “Cooling air supply in junction box” for internally cooled device types

Option “Cooling air supply in junction box” can be used for the detached control unit MCU, which can be more than 10 meters away from the measuring point. The cooling air supply is installed at the measuring point considering the maximum cooling air hose length of 10 meters. It is possible to install the MCU (version MCU-N without integrated blower unit) detached from the measuring point using long line lengths (→ p. 97, §3.3.6).

2.3.8 Cooling air control option for device types M-AC and H-AC

The “Cooling air control for device types M-AC and H-AC” subassembly serves minimizing the number of temperature drops below the dew point on the ultrasonic transducer. The cooling air blower is switched on or off depending on the transducer temperature. Cooling therefore only runs for appropriately high gas or transducer temperatures. This prevents permanent cooling air operation overcooling the probe. Setting the required limit values for switching the cooling air supply on and off is made in SOPAS ET (→ p. 150, 4.3.5).

2.3.9 Optional sets for emergency air supply for device types with cooling and purge air operation

The optional sets for emergency air supply serve preventing severe damage to transducers should the purge air/ cooling air supply fail. The sets are usable as described in the respective written versions for the FLOWSIC100 measuring system with 1-path configuration, SOPAS application setting “FLOWSIC100”. The emergency air supply systems monitor failures in supply voltage for the purge air/cooling air blower. Prerequisite for using this set is the onsite provision of compressed air free from oil and dust.

**WARNING:**

The emergency air supply systems only provide temporary protection for transducers against overheating (several hours) and must never be used as alternatives for standard purge air/cooling air supply because there is a risk that the emergency air supply systems create interfering noise on the transducers and therefore influence measurement. On devices purged externally (FL100 PM, PH and PH-S), there is also a risk of the emergency air not keeping transducer surfaces sufficiently clean.

2.3.9.1 Emergency air supply for device types M-AC and H-AC

Prerequisites:

- 1 Compressed air free from oil, dust and water provided by the customer.
- 2 Compressed air requirement about 9...11 m³/h
- 3 Primary pressure at least 1.5 bar (measurable with emergency air in operation).

Cooling function during normal device operation (→ p. 87, 3.3.4.1)

In normal operation, cooling air for sender/receiver units is supplied via the MCU blower unit or, optionally, via a blower unit in a separate enclosure (→ p. 180, Fig. 149).

Air path in normal operation (cooling air supply via MCU blower unit):

- Air entry in the MCU suction opening - air filter - blower unit - flexible DN25 hoses - backflow valve - cooling air inlet S/R unit - cooling air discharges from S/R unit (after deflection in probe tube).

The “backflow valve” is open in forward direction (rubber poppet valve).

Cooling function in emergency operation (cooling air failure due to interruption or failure of the voltage supply to the cooling air blower)

An installed solenoid valve releases a flow of compressed air should the standard cooling air fail. If the compressed air flow is pressurized, the emergency air valve (→ p. 87, Fig. 59) with integrated backflow valve closes in the blocking direction and the compressed air flows into the cooling channels of both S/R units (→ p. 87, Fig. 59).

2.3.9.2 **Emergency air supply for device types PM, PH and PH-S**

Prerequisites:

- 1 Compressed air free from oil, dust and water provided by the customer.
- 2 Compressed air requirement:

Gas temperature	Primary pressure	Consumption
Up to 200 °C	1.0 bar	Approx. 6 m3/h
Up to 300 °C	1.5 bar	Approx. 8 m3/h
Up to 400 °C	2.0 bar	Approx. 10 m3/h

Versions:

Designation	Part No.
Emergency air supply for 1 purge air unit 380 V AC	7042118
Emergency air supply for 1 purge air unit 230 V AC	7042117
Emergency air supply for 2 purge air units 230 V AC	7042119
Emergency air supply for 2 purge air units 380 V AC	7042120

2.3.10 **Measuring tube option**

A tube piece, as shown in Fig. 25, can be supplied for pipelines with diameters up to max. DN500 for easy mounting (welding the flanges with tube). Basis for exact design are customer-specific data.

Fig. 25

Measuring tube option

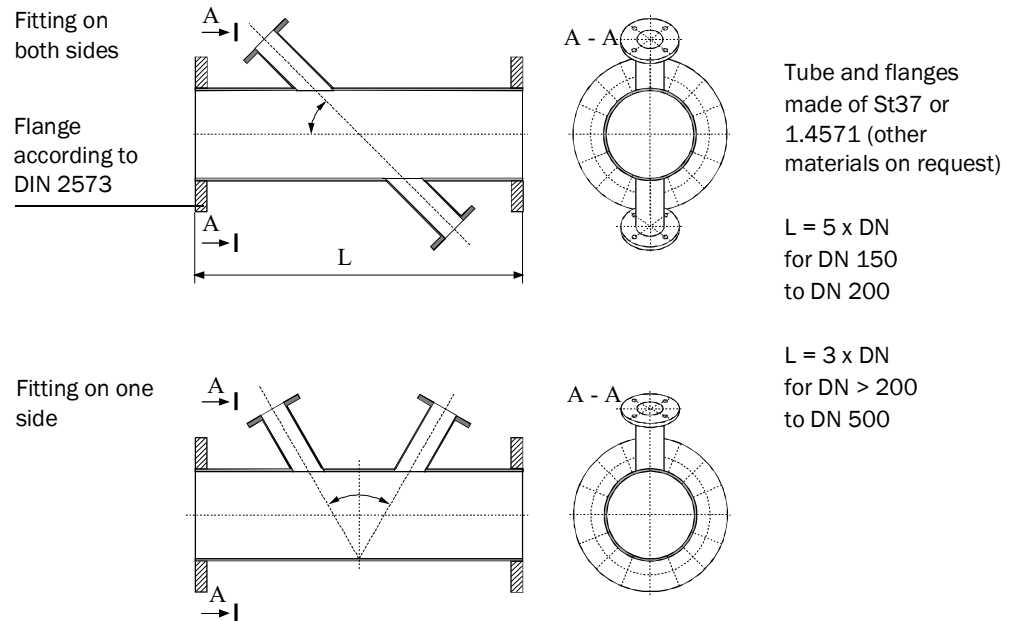

Subject to change without notice

2.4 Computations

2.4.1 Calculating and calibrating the volume flow

Volume flow in operating state

Acoustic velocity monitors from the FLOWSIC100 series are usually used to determine the volume flow in closed pipes and ducts. The volume flow $Q_{a.c.}$ through the representative cross-sectional area A and the mean gas flow rate across the cross-section v_A (area velocity) is defined as:

$$Q_{act.} = v_A \cdot A$$

The FLOWSIC100, however, determines the representative mean value of the flow velocity on a sound path v (path velocity) between the two sender/receiver units. The sound path is generally arranged across the diameter (→ p. 51, 3.1.1).

Since the mean values of the path and area velocity are not identical (particularly in small duct diameters), a functional, systematic correlation between the calculated path velocity and the mean area velocity similar to the point-based flow measurement (for example, a pitot tube probe) has been introduced.

$$v_A = K \cdot v \quad K = \text{correction function}$$

The correction factor k can be used for K with unimpeded, axial-symmetric flow profiles in round pipes.

$$k = \frac{v_A}{v} \quad 0.9 < k < 1$$

In many cases, however, an unimpeded, axial-symmetric flow profile is not guaranteed due to the installation conditions (short inlet sections, rectangular ducts, unsymmetrical flow profiles, and so on). For this reason, a second degree calibration function has been implemented in FLOWSIC to show the relation between middle path and area velocity.

$$v_A = Cv_{-2} \cdot v^2 + Cv_{-1} \cdot v + Cv_{-0}$$



If the flow in a round pipeline is unimpeded and axial-symmetric, Cv_{-1} is equal to the correction factor k .

The coefficients in this calibration function can be determined by means of network measurements and regression analysis (see DIN EN 13284-1). The calculated regression coefficients must then be entered in the measuring device using SOPAS ET (→ p. 151, 4.3.6).

Default values from the factory are $Cv_2 = 0$, $Cv_1 = 1$, $Cv_0 = 0$.

Calculating the volume flow in standard state

The volume flow can be converted to the standard state as follows:

$$Q_{i.N.} = Q_{i.B.} \cdot \left(\frac{100 - F}{100} \right) \cdot \left(\frac{p_{duct} \cdot T_{normal}}{p_{normal} \cdot T_{duct}} \right)$$

$Q_{act.}$: Volume flow in operating state

$Q_{std.}$: Volume flow in standard state

F: Humidity in percentage volume, parameter normally set as default value typical for the system.

If an optional analog module is used as an analog input for connecting a separate humidity monitor, the volume flow can be scaled with the current installation values.

p_{duct} : Absolute pressure in duct, normally set as parameter as fixed/default value typical for the system.

If an optional analog module is used as an analog input for connecting a separate pressure sensor, the volume flow can be scaled with the current installation values.

p_{normal} : 1013 mbar

T_{duct} : Duct temperature (in K): Here in FLOWSIC100, either a permanent default temperature calculated with ultrasound measurement or read via the optional analog input (for greater accuracy) can be selected for use.

T_{normal} : Standard temperature. In Europe 273 K, in USA 293 K

2.4.2

Temperature calibration

The temperature measurement must be calibrated for exact calculation of the flue-gas temperature with the FLOWSIC100. There are only two cases where this calibration is not necessary:

- Exact knowledge of the sound velocity in the flue gas under standard conditions (1013 mbar, 0 °C), as is the case with air, for example, (331 m/s)
- Exact knowledge of the active measuring path.

Calibration is carried out using a reference measurement with a separate temperature sensor (for example, Pt100) with at least 2 different temperatures (calculating and entering the coefficients → p. 151, 4.3.6).

2.4.3 Damping time

The damping time is the time taken by the measuring device to reach 90% of the end value after a sudden change in the measured value (→ Fig. 26).

The damping time can be set to any value in the range 1...300 s. Setting a higher damping time (typically: 60...90 s) provides better attenuation of transient fluctuations in the measured value and interference to produce a “smoother” output signal.



Recommended value: 60 ... 90 s

A special damping time is used to measure the gas flow rate and gas temperature. Volume flow and gas velocity have the same response time.

Fig. 26

Damping time

Measured value

in %

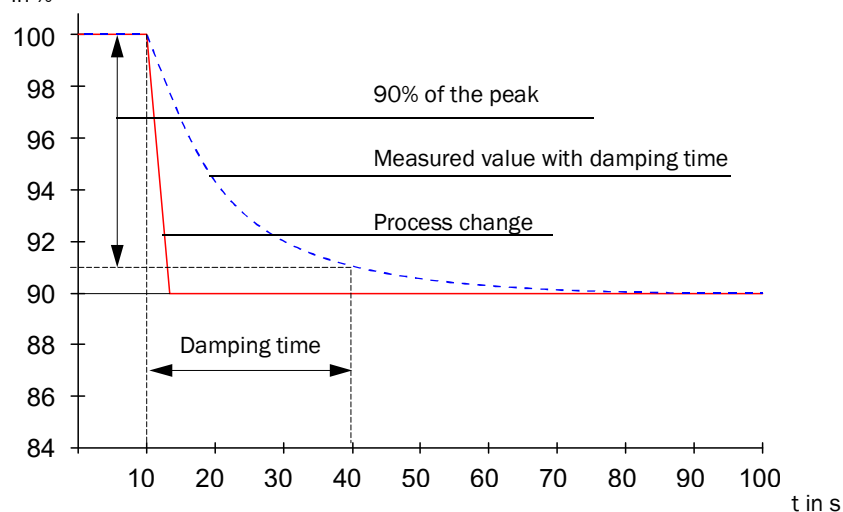

The damping time should be regarded as a guide value. If the signal quality of the ultrasonic pulses is poor, the FLOWSIC100 requires more measured values to produce an output signal of the same accuracy. As a result, the damping time is higher, within certain limits, than the set time.

2.5

Check cycle

A check cycle can be triggered on the FLOWSIC100 to test whether the device components are functioning correctly. The check cycle can also be triggered automatically (the interval can be set using SOPAS ET) and/or via a digital input (→ p. 29, 2.3.3). Any deviations from normal behavior are output as a warning or error.

If a malfunction is present or a warning is displayed, a check cycle can be triggered manually to locate the cause of the problem (see Service Manual).

The check cycle consists of a zero point control and span test. The check values can be output via the analog output. The progress of the check cycle is output on the corresponding relay and, if the display module option is used, indicated by the text “Check cycle” on the display.



- If the check cycle is not output on the analog output, the last measured value is output for the duration of the check cycle (approx. 20 s if the check runs correctly).
- To trigger a zero point control and span test, as well as a check cycle via a digital input, a contact must be closed at the corresponding terminals for at least 2 s.
- Automatic check cycles are carried out periodically from the configured time interval, until the interval setting is changed (or the device is reset). After a device reset (or power failure), the check cycle begins at the defined time when the device resumes operation.
- If the automatic check cycle and check cycle triggered via a digital input occur at the same time, only the cycle triggered first takes effect.

2.5.1

Zero point control

A special circuit arrangement in the sender/receiver units ensures transmission signals from the transducers can be read back without delay and with the original waveform. These transmission signals are received as reception signals, amplified, demodulated, and evaluated. If the device is operating correctly, the exact zero point is calculated here. This check comprises a full check of all the system components, including the transducers. A warning is output for offsets greater than approx. 0.25 m/s (depending on the measuring path and gas temperature). In this case, check the transducers and electronic components. If the signal amplitude or waveform does not match the expected values, the transducers or electronic components are defective and, in this case, an error message is output.

2.5.2 Span test

During the electronic zero point test, the time difference between both directions of signal transmission is determined and computed with the system parameters gas temperature, measuring path and sound velocity as a velocity offset at the zero point. This offset is added to the selected span value and output. The span value can be set to between 50 and 70% in steps of 1% using SOPAS ET (default value from the factory 70%). The complete measuring system will respond in the prescribed manner when all system components are intact.

2.5.3 Check cycle output on the analog output

A check cycle is output as follows:

- 90 s zero value (live zero)
- 90 s span value



- The output duration of 90 s is the default factory setting. The value can be changed in SOPAS ET (→ p. 130, 4.2.3)
- This output is only expedient for measured values that depend on velocity (gas flow rate, volume flow act., volume flow std.).

FLWSIC100

3 Assembly and installation

Project planning

Assembly

Installation

3.1 Project planning

The following Table provides an overview of the project planning work to be carried out to ensure the device is correctly installed and fully functional. You can use this Table as a checklist by ticking off all the steps you have carried out.

Task	Requirements		Work step	<input checked="" type="checkbox"/>
Determine the measuring and installation locations for the device components (→ p. 51, 3.1.1)	Inlet and outlet sections must be of sufficient length Homogeneous flow distribution	If possible, no bends, cross-section variations, feed pipes, discharge pipes, flaps, or fittings in the inlet and outlet sections	Comply with specifications for new installations; choose the best possible location for existing installations; if necessary, determine flow profile in accordance with DIN EN 132841; if inlet/outlet sections are too short: Inlet section > outlet section.	<input type="checkbox"/>
	Accessibility, accident prevention	Device components must be easily and safely accessible	Provide platforms or pedestals when necessary	<input type="checkbox"/>
	Vibration-free installation	Accelerations < 1 g	Take appropriate measures to eliminate/reduce vibrations	<input type="checkbox"/>
	Ambient conditions	Limit values in accordance with Technical Data	If necessary: Fit weatherproof covers/sun protection Cover or insulate device components.	<input type="checkbox"/>
	Purge air supply (for purged FLSE100 only)	Clean intake air (as little dust as possible, no oil, humidity, corrosive gases)	Choose the best possible intake location	<input type="checkbox"/>
	Instrument air (only for optional emergency air sets for purged/cooled device types)	Free from oil, dust and grease	Choose the best possible installation location	<input type="checkbox"/>
Choose the device components	Internal duct diameter	Type of sender/receiver unit	Choose components according to the Configuration Table and information in → p. 17, 2.3. If necessary, plan additional measures to install the flange with tube (→ p. 60, 3.2.1).	<input type="checkbox"/>
	Duct wall strength with insulation	Nominal length of sender/receiver unit, flange with tube		
	Internal duct pressure	Type of sender/receiver unit; purge air unit version (for purged FLSE100)		
	Gas temperature	Type of sender/receiver unit (standard or internally cooled) Purge air supply for purged FLSE100		
	Dust concentration	Type of sender/receiver unit		
	Gas composition	Material of duct probe and transducer		
	Installation locations	Cable and purge air hose lengths		
Plan the calibration openings	Accessibility	Easy and safe	Provide platforms or pedestals when necessary	<input type="checkbox"/>
	Distances to the measurement level	No mutual interference between calibration probe and FLOWSIC100	Ensure sufficient distance between the measurement and calibration level (approx. 500 mm)	<input type="checkbox"/>
Plan the voltage supply	Operating voltage, power requirements	In accordance with Technical Data in → p. 166, 6.1	Ensure sufficient cable cross-sections and fuse	<input type="checkbox"/>

Subject to change without notice

3.1.1

Determining the measurement and installation location

Flow profile

Measuring precision is subject to the flow conditions and the position of the measurement axis. Significant changes in the cross-section, duct curvatures, fittings in the duct, air dampers, or inlets can cause profile deformations or turbulence that will impair the result of the measurement. To ensure measurement is as accurate and trouble-free as possible, select a measuring location where the gas flow is, to a large extent, homogeneous (→ Fig. 27).

Regular, unimpeded profiles are most likely with long inlet and outlet sections. The longer the inlet section, in particular, the greater the reproducibility of the measurement results. If possible, the inlet section should be more than 20 times greater, and the outlet section 10 times greater than the internal diameter of the duct (D_i). With rectangular cross-sections, the diameter is calculated as 4 times the cross-section divided by the duct circumference.

On existing installations, choose the optimum location.

If flow conditions are uncertain, measure the profile at the measuring location, for example, using dynamic pressure probes (see DIN EN 13284-1). Calibration apertures must be provided for this purpose. The measuring axis must then be defined in such a way that any changes in the profile will only have a minimum impact on the result of the measurement.

If the FLOWSIC100 is to be used for official measurements (for example, emission measurements pursuant to BImSchV), the measuring location should be determined by a legally authorized expert (for example, by means of an expert appraisal of a measuring location authorized in accordance with BImSchV Articles 26 and 28).

Fig. 27

Installing the sender/receiver units

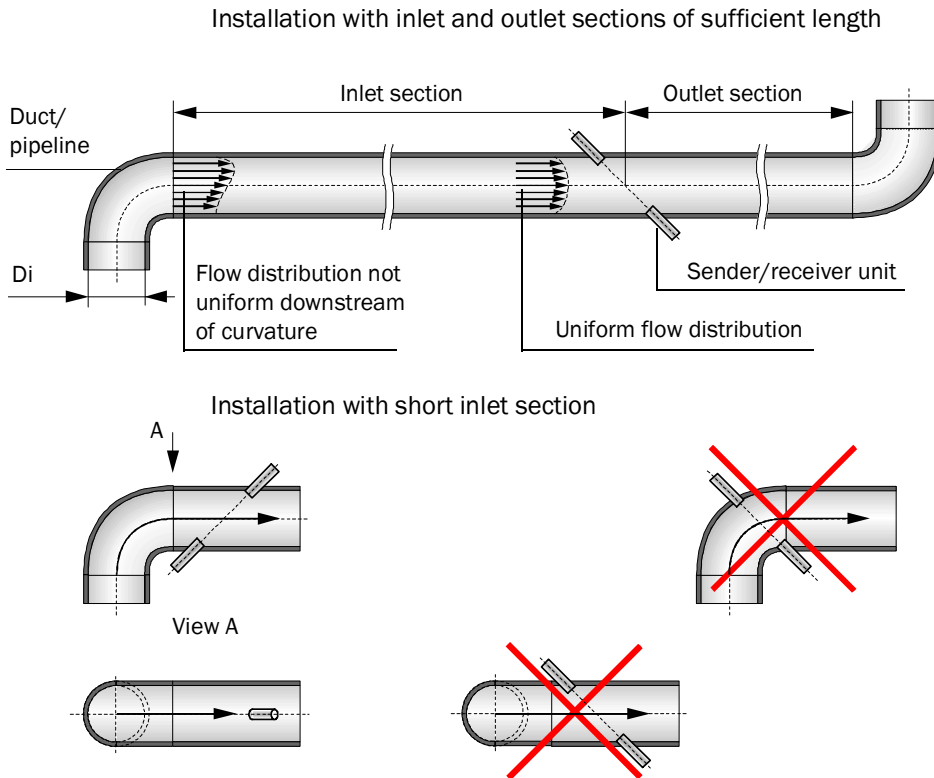

Subject to change without notice

Installation location

The sender/receiver units can be installed on vertical, horizontal, or inclined ducts or pipelines. In vertical stacks, a minimum distance from the stack outlet (approx. 30 m) must be observed to prevent noise disturbance caused by rain drops on the probe head. The installation location for the device components must be as free as possible from vibrations.

If a purge air/cooling air unit is required, it must be mounted at a location that allows intake of the cleanest possible air. The intake temperature must match the values specified in the Technical Data.

Ensure a connection for instrument air free from oil, dust and grease is available at the fitting location when using optional emergency air supply sets.

The installation location should be equipped with power connections and permanent lighting.

Platform

The sender/receiver units must be easily accessible for installation and maintenance. If necessary, provide a suitably wide platform secured by a handrail.

**WARNING:**

The plant operator is responsible for ensuring that the applicable accident prevention and occupational health and safety regulations are observed.

In vertical ducts, the installation angle should be selected depending on the duct diameter so that only one platform is necessary. An additional basic platform and/or sealable opening in the platform with a protection cage or similar can be helpful (→ Fig. 28). Ensure sufficient clearance is provided for installing and removing the sender/receiver units.

Fig. 28

Installing the sender/receiver units on a vertical duct

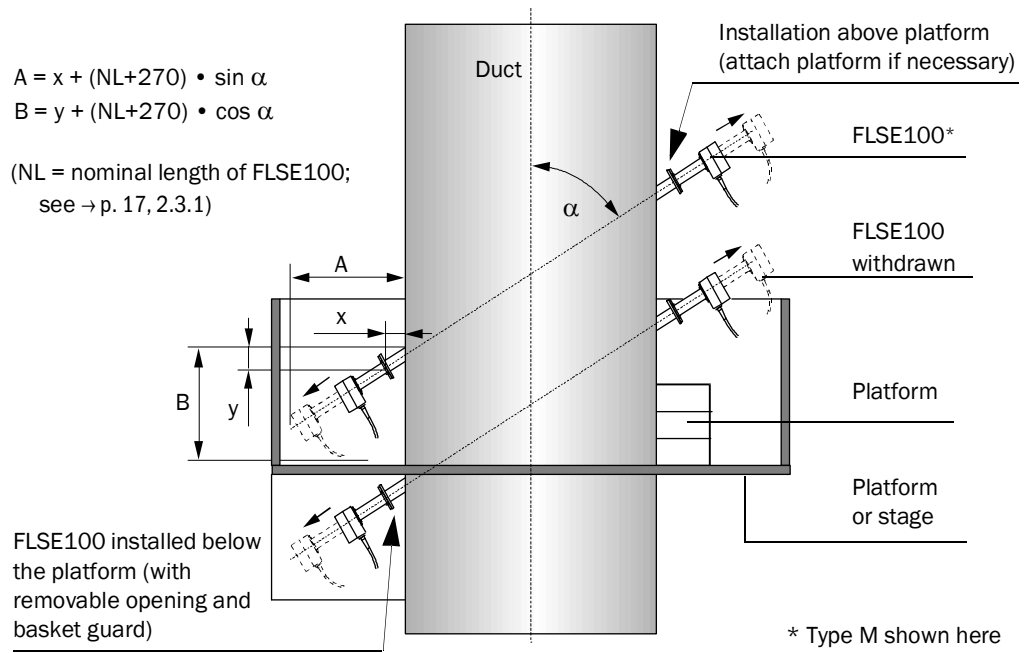

Select an installation angle of 60° for duct diameters as from approx. 4.5 m.

3.1.2 Further planning information

Installing the FLSE100 in horizontal ducts

On horizontal ducts and pipelines, the sender/receiver units should be installed slightly inclined from horizontal to prevent possible condensate from entering the duct (→ Fig. 29).

Fig. 29 Installing the sender/receiver units on horizontal ducts

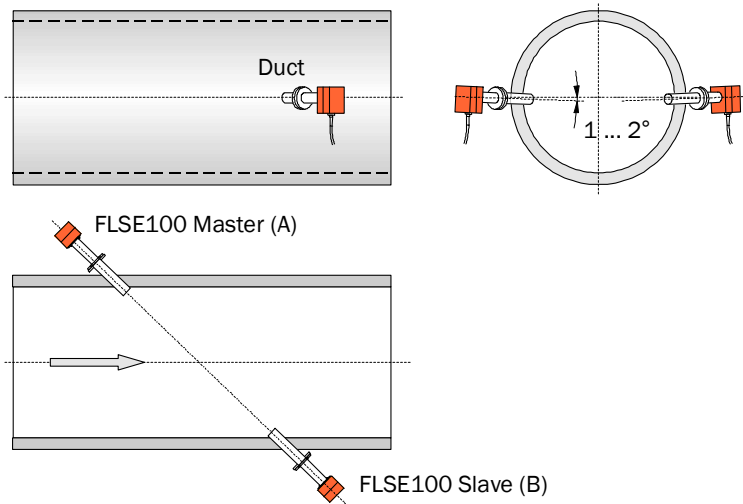

NOTICE:

On FLOWSIC100 S devices, the sender/receiver unit FLSE100-SD with electronics unit is the master.

Installing the sender/receiver unit type FLSE100-PR

Fig. 30

Installing the sender/receiver unit type FLSE100-PR

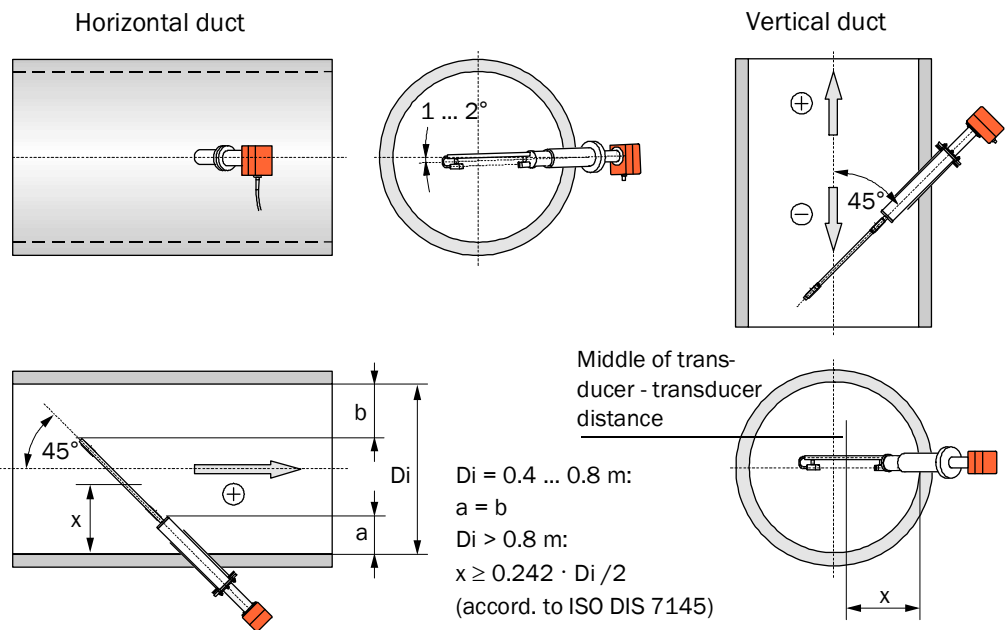

x = representative wall clearance at which the local gas flow rate is the same as the mean velocity in the duct cross-section

Sender/receiver units with special lengths can be delivered if the condition for x with standard nominal lengths cannot be observed.



In vertical ducts, a negative sign is shown on the LC-Display of the control unit when the flow direction is from top to bottom. To change the displayed values to positive values, enter a negative linear regression coefficient (→ p. 144, 4.3).

Preventing condensate accumulations

If standard sender/receiver units are installed in vertical ducts, wet gases can cause condensate to accumulate in the flange tube of sender/receiver unit A (→ p. 15, Fig. 4). The following onsite solutions can help prevent measuring problems (malfunctions caused by solid-borne noise, see Service Manual), or damage when removing the sender/receiver unit (condensate runs out):

- Completely insulating the flange with tube (reduces temperatures on the flange with tube below the dew point)
- Draining continuous or periodical condensate through an opening (if necessary closeable) at the deepest point of the flange tube (e.g. hole $\varnothing 4 \text{ mm}$ with plug: → Fig. 31) (only when the condensate cannot damage the system or the environment)
- Returning the condensate to the duct through a hose connection between flange tube and duct (→ Fig. 31).

Fig. 31

Condensate drain / backflow

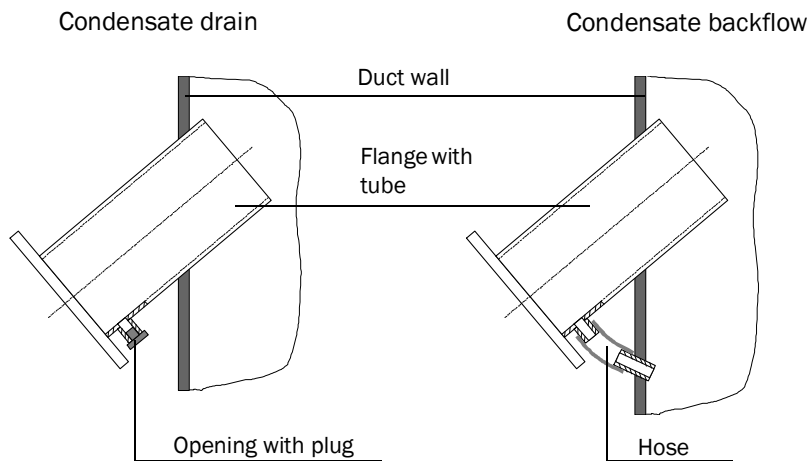

Using the sender/receiver units with high dust contents (> 1 g/m³)

The measuring path must be as short as possible. This requires installing the sender/receiver units at an angle of 60° to the flow direction.

In addition, fit impact protectors on the downstream sender/receiver unit (→ p. 15, Fig. 4) on types FLSE100-PH / PHS and H / HAC to prevent particles impacting on the transducer surface causing malfunctions impairing measuring behavior.



See → »Shortening the measuring path« (page 58) for further options.

3.1.3 Selecting the flanges with tube

The criteria listed under → p. 28, 2.3.2 are applicable for selection.

Inside coated ducts

The following points must also be taken into account when the inside of the duct/pipeline is coated (rubber insulation):

- Since the inside of the flange tubes also has to be coated, it might be necessary to select flange tubes with a larger inside diameter. The minimum distance between the probe tube and flange tube is 3 mm.
- If a standard flange with tube cannot be used, make the flanges with tube onsite (deliverable by SICK on request).
- To ensure coating is complete, the flanges must be mounted before being coated.

Plastic ducts

The standard flanges with tube generally cannot be used for plastic ducts/pipelines. Possible solutions (to be carried out onsite):

- On GRP ducts¹: Laminate the steel core with pitch diameter of the mounting holes. The inside diameter of the laminated flange tube must match the selected FLSE100.
- Use flanges with tube made from duct/pipe material; weld-mount or fit with plastic adhesive.
- Mount adapter flanges on openings prepared onsite.

Determining the nominal length

The required nominal length of the flanges with tube can be determined using the following Figures.

Fig. 32

Determining the nominal length of the flanges with tube

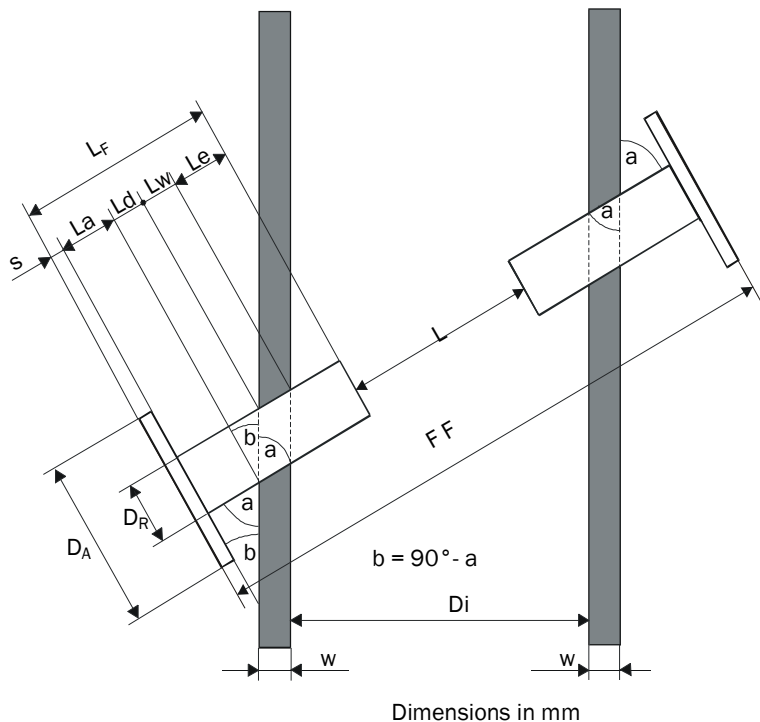

- L_f = Length of flange with tube (minimum)
- L_e = Draw-in length (min. 20)
- D_A = Outer diameter of flange
- D_R = Outer diameter of tube
- α = Installation angle
- s = Flange thickness = 10
- L = Active measuring path (input value)
- w = Thickness of duct wall + insulation
- D_i = Inside diameter of duct

$$L_w = \frac{w}{\sin \alpha}$$

$$L_d = D_R \cdot \tan \beta$$

$$L_{a \min} = \frac{(D_A - D_R)}{2} \cdot \tan \beta$$

$$L_{F \min} = s + \frac{(D_A + D_R)}{2} \cdot \tan(90^\circ - \alpha) + \frac{w}{\sin \alpha} + L_e$$

$$L = \frac{D_i}{\sin \alpha} - 2 \cdot L_e - L_d$$

Dimensions in mm

Subject to change without notice

1 GRP = glass fiber reinforced plastic

Maximum possible wall (and insulation) thickness as a function of the nominal length of the flanges with tube, flange size (pipe diameter D_R) and installation angle α ($L_e = 20$ mm):

Nominal length L_F [mm]	Maximum wall and insulation thickness w [mm]					
	$D_R = 114.3$		$D_R = 76.1$		$D_R = 48.3$	
	$\alpha = 45^\circ$	$\alpha = 60^\circ$	$\alpha = 45^\circ$	$\alpha = 60^\circ$	$\alpha = 45^\circ$	$\alpha = 60^\circ$
125					15	45
200			49	97	68	110
350	112	196	155	227	174	240
550	253	369	297	400	315	413
750	395	543	438	573		

Shortening the measuring path

It may be necessary to shorten the measuring path to prevent problems in signal transmission in certain cases, e.g. when using types FLSE100H, HAC, PH or PHS with high dust concentrations (\rightarrow p. 17, 2.3.1). This can be achieved by installing extended flange tubes and/or flanges with tube across the secant.

The installation conditions are shown in Fig. 33 and in the following Table.

Fig. 33

Installation across secant

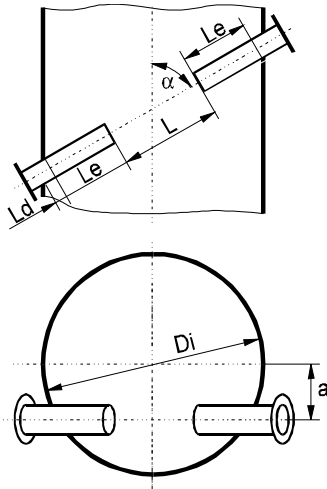

- L = Active measuring path
- L_e = 20 ... 500 mm
- $a_{max} = D_i / 4$
- $a = 60^\circ$
- L_d as in Fig. 32

With $a = a_{max}$ and circular ducts then ($\alpha = 60^\circ$)

$$D_{i_{max}} = L + 2 L_e + L_d$$

Correlation between inside diameter Di and measuring path L depending on draw-in length Le and installation type (dimensions in m):

Di	Measuring path L at a = 60°, Le = ... and installation across											
	Diameter										Secant	
	Le=0.05	Le=0.10	Le=0.15	Le=0.20	Le=0.25	Le=0.30	Le=0.35	Le=0.40	Le=0.45	Le=0.50	Le=0.50	a _{max}
1.00	1.01											
1.05	1.07											
1.10	1.13	1.03										
1.15	1.18	1.08										
1.20	1.24	1.14	1.04									
1.25	1.30	1.20	1.10	1.00								
1.30	1.36	1.26	1.16	1.06								
1.35	1.41	1.31	1.21	1.11	1.01							
1.40	1.47	1.37	1.27	1.17	1.07							
1.45	1.53	1.43	1.33	1.23	1.13	1.03						
1.50	1.59	1.49	1.39	1.29	1.19	1.09						
1.55	1.65	1.55	1.45	1.35	1.25	1.15	1.05					
1.60	1.70	1.60	1.50	1.40	1.30	1.20	1.10	1.00				
1.65	1.76	1.66	1.56	1.46	1.36	1.26	1.16	1.06				
1.70	1.82	1.72	1.62	1.52	1.42	1.32	1.22	1.12	1.02			
1.75	1.88	1.78	1.68	1.58	1.48	1.38	1.28	1.18	1.08			
1.80	1.93	1.83	1.73	1.63	1.53	1.43	1.33	1.23	1.13	1.03		
1.85	1.99	1.89	1.79	1.69	1.59	1.49	1.39	1.29	1.19	1.09		
1.90		1.95	1.85	1.75	1.65	1.55	1.45	1.35	1.25	1.15		
1.95		2.01	1.91	1.81	1.71	1.61	1.51	1.41	1.31	1.21		
2.00			1.97	1.87	1.77	1.67	1.57	1.47	1.37	1.27		
2.05				1.92	1.82	1.72	1.62	1.52	1.42	1.32	1.01	0.51
2.10				1.98	1.88	1.78	1.68	1.58	1.48	1.38	1.06	0.53
2.15					1.94	1.84	1.74	1.64	1.54	1.44	1.11	0.54
2.20					2.00	1.90	1.80	1.70	1.60	1.50	1.16	0.55
2.25						1.95	1.85	1.75	1.65	1.55	1.21	0.56
2.30							1.91	1.81	1.71	1.61	1.26	0.58
2.35							1.97	1.87	1.77	1.67	1.31	0.59
2.40								1.93	1.83	1.73	1.36	0.60
2.45								1.99	1.89	1.79	1.41	0.61
2.50									1.94	1.84	1.46	0.63
2.55									2.00	1.90	1.51	0.64
2.60										1.96	1.56	0.65
2.65											1.61	0.66
2.70											1.66	0.68
2.75											1.71	0.69
2.80											1.76	0.70
2.85											1.81	0.71
2.90											1.86	0.73
2.95											1.91	0.74
3.00											1.96	0.75

Subject to change without notice

3.2 Assembly

All the assembly work has to be carried out onsite. This includes:

- ▶ Installing the flanges with tube or glands for high-pressure versions
- ▶ Fitting the control unit
- ▶ Installing the purge air unit accessory
- ▶ Fitting weatherproof covers



WARNING:

- When carrying out assembly and installation work, observe the relevant safety regulations and safety information in Section 1!
- Assembly and installation work on potentially dangerous installations (hot or corrosive gases, high internal duct pressure) must only be carried out when the system is shut down!
- Suitable protective measures must be taken to protect against local or system-specific danger.

3.2.1 Installing the flanges with tube

3.2.1.1 Duct/pipe diameter > 0.5 m

Work to be performed

- ▶ Measure out the installation location so that the planned installation angle is reached (if mounting two flanges with tube, observe the diameter) and mark the installation location.
- ▶ Remove the insulation (if present).
- ▶ Cut out suitable oval openings in the duct wall; drill suitably sized holes in brick and concrete ducts (see the Annex for templates for openings).



NOTICE:

Make sure parts cut off do not fall into the duct!

- ▶ Insert the flange with tube in the opening as shown in Fig. 34,
 - Observe the minimum draw-in length L_e (>20 mm or as shown in Fig. 33 and Table)
 - Roughly align it and tack it into position with a few spot welds
 - With brick and concrete ducts, tack it to a holding plate (→ p. 61, Fig. 35).

Fig. 34 Fitting the flanges with tube

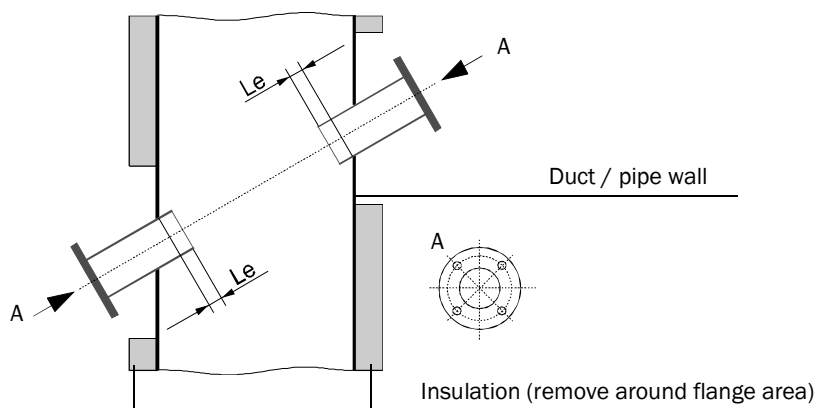



When installing FLSE100-PR sender/receiver units, insert the flange with tube as far as possible into the duct (with the longest possible length L_e).

Fig. 35

Fitting options for the flange with tube

Flange with tube welded to a stable and sturdy steel wall

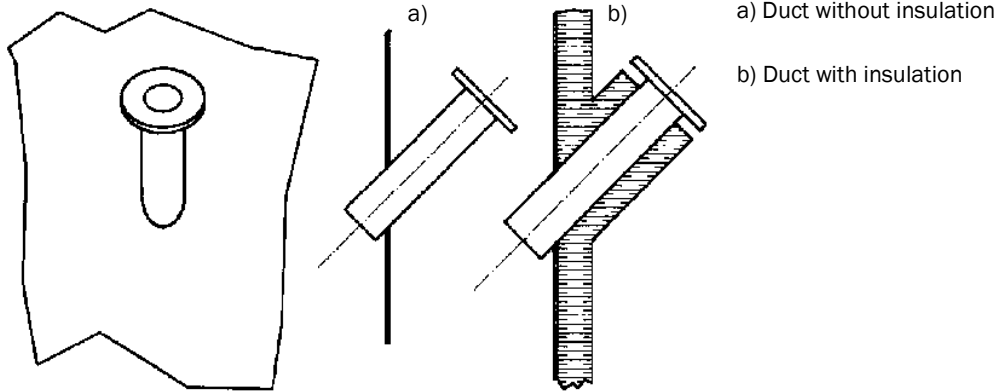

Flange with tube welded to thin steel wall

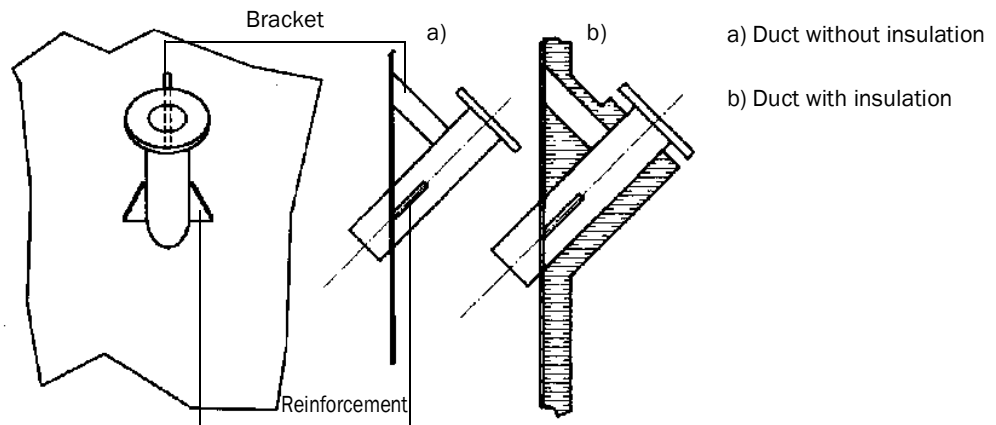

Flange with tube mounted on brick or concrete duct

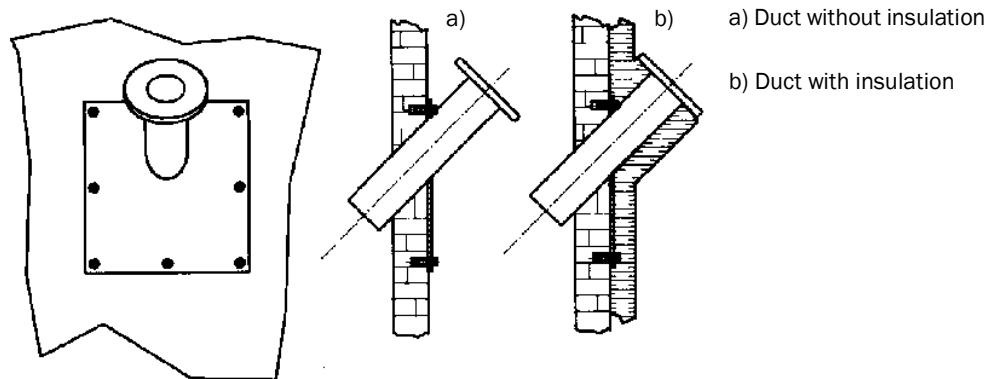

- ▶ When fitting two flanges with tubes, align both exactly to each other after tacking using a suitable tube (for smaller ducts) or using the SICK adjustment aid (can be provided on loan) (see Fig. 36).



NOTICE:

Only use the optical adjustment tool (Part No. 1700462) for sender/receiver units with connection K100 (types FLSE100-H, H-AC, PM and PH) and for duct diameters up to max. 3 m.

Fig. 36

Aligning the flange using the optical alignment device

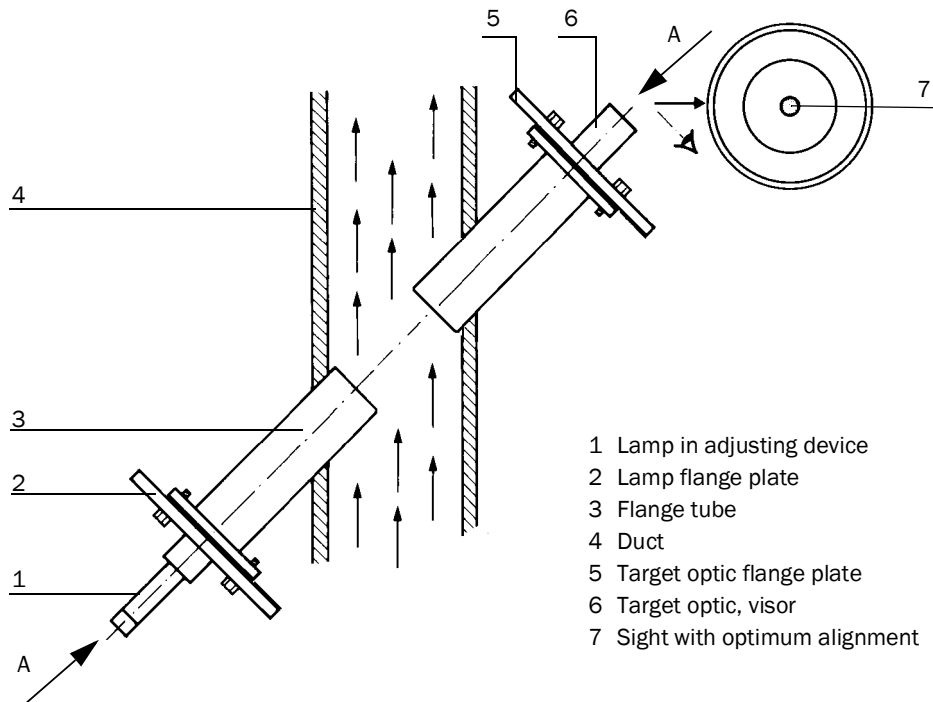

- 1 Lamp in adjusting device
- 2 Lamp flange plate
- 3 Flange tube
- 4 Duct
- 5 Target optic flange plate
- 6 Target optic, visor
- 7 Sight with optimum alignment



Align the flange with target optics so that the light spot of the lamp appears in the center of the target optics.

- ▶ Weld on the flange tubes, while constantly ensuring that the alignment is exact (correct if necessary). When using the alignment device, first reposition the flange plate with lamp and flange plate with target optics before welding the second flange tube on.
- ▶ Measure and note the installation angle for configuring the parameters later.
- ▶ Measure and note the distance between the two flanges (dimension F-F in Fig. 32) and make a note of it for configuring the parameters later. The DME 2000 distance sensor from SICK can be used (consult SICK, if required) for this purpose.
- ▶ With thin-walled ducts/lines, provide suitable brackets/reinforcement to prevent distortion and vibration (→ p. 61, Fig. 35).
- ▶ Seal the flange with a blind plug (optional).
- ▶ Insulate the flange tube (if necessary).



- When mounting two flanges with tube, the alignment of the two flange tubes has priority over the installation angle.
- Distortions as a result of temperature changes or mechanical stresses can change the measuring path.

3.2.1.2 Duct/tube diameter < 0.5 m

The work is generally the same as for larger diameters. The difference with small diameters is that installing the flanges and sender/receiver units can have a greater impact on the flow characteristics. To minimize this impact, the flange tubes should not be inserted in the pipeline, but rather mounted and welded flush on the outside.

Two options are available for installation (→ Fig. 37):

- On two sides
- On one side, using the sound reflection on the opposite inside wall. This solution can be used with very small ducts to lengthen the measuring path, or if access is only possible from one side.

Fig. 37 Fitting the flanges with tube

Fitting on both sides

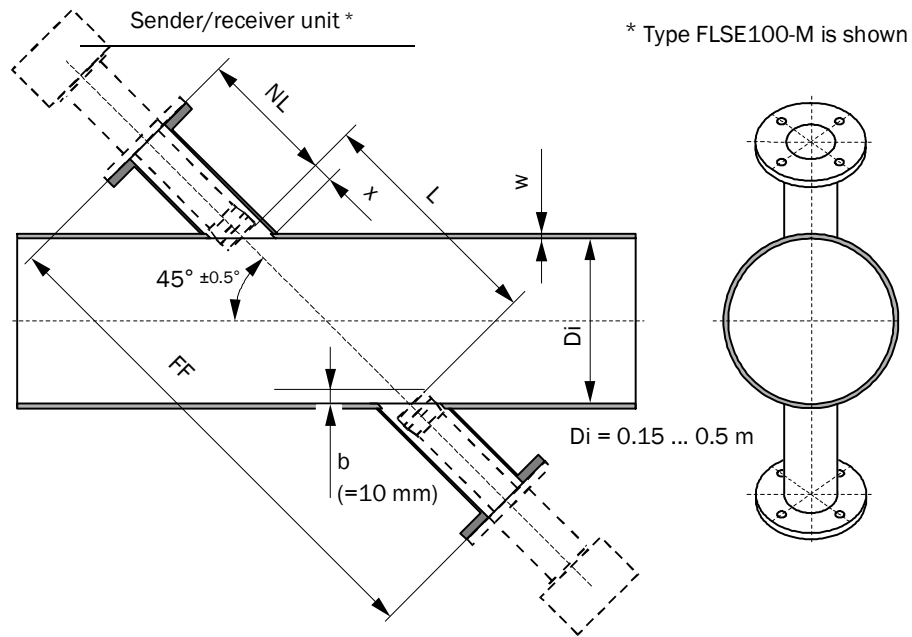

Fitting on one side

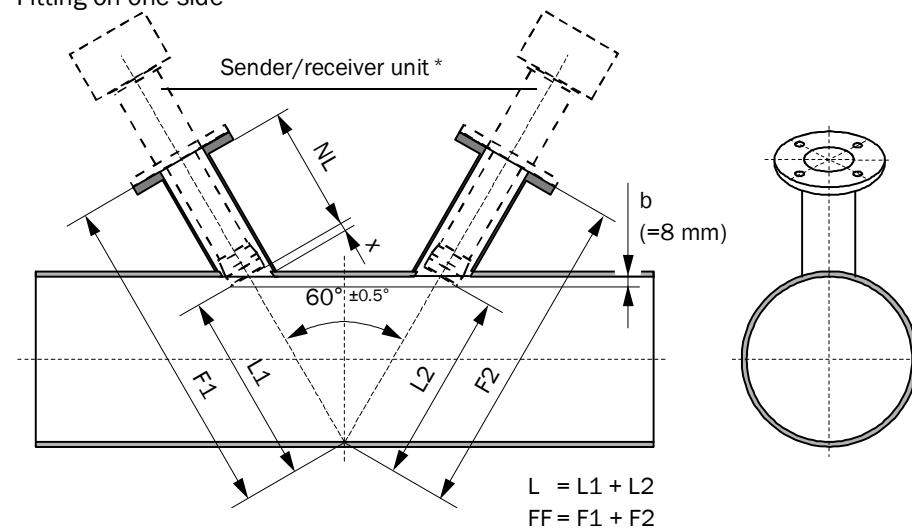

Carry out the following before fitting the flanges with tube:

- ▶ Cut out suitable oval openings in the duct wall (see Annex for templates).
- ▶ Bevel the flange tubes at an angle of 45° or 60°.
- ▶ If necessary, adapt the flange tubes to the wall curvature as shown in Fig. 38.

Fig. 38

Adapting the flanges with tube

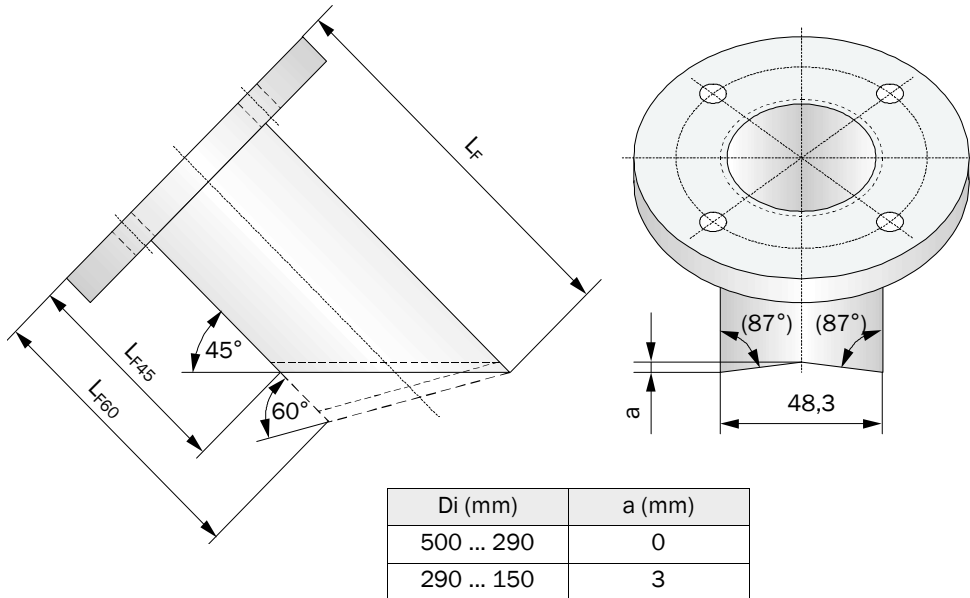

Flange tube length L_F (L_{F45} , L_{F60}) depends on installation angle α , wall thickness w and nominal length NL (\rightarrow Fig. 37, \rightarrow Fig. 38). This correlation is expressed by the following formulas:

$$L_F = NL + x \quad L_{F45} = L_F - 48.3 \quad L_{F60} = L_F - 27.9$$

$$x = \frac{48,3 + 35}{2 \cdot \tan \alpha} - \frac{(w + b)}{\sin \alpha}$$

α	b
45°	10
60°	8

A selection of values is provided in the following Table. The Table shows that flanges with tube with the next longest nominal length than that of the sender/receiver units must be selected.

			Tube length L _F , L _{F45} /L _{F60} at nominal length NL									
			NL=125		NL=200		NL=310		NL=350		NL=550	
α	w	x	L _F	L _{F45}	L _F	L _{F45}	L _F	L _{F45}	L _F	L _{F45}	L _F	L _{F45}
45°	1	26.1	151.1	102.8	226.1	177.8	336.1	287.8	376.1	327.8	576.1	527.8
	2	24.7	149.7	101.4	224.7	176.4	334.7	286.4	374.7	326.4	574.7	526.4
	3	23.3	148.3	100.0	223.3	175.0	333.3	285.0	373.3	325.0	573.3	525.0
	4	21.9	146.9	98.6	221.9	173.6	331.9	283.6	371.9	323.6	571.9	523.6
	5	20.4	145.4	97.1	220.4	172.1	330.4	282.1	370.4	322.1	570.4	522.1
	6	19.0	144.0	95.7	219.0	170.7	329.0	280.7	369.0	320.7	569.0	520.7
	7	17.6	142.6	94.3	217.6	169.3	327.6	279.3	367.6	319.3	567.6	519.3
	8	16.2	141.2	92.9	216.2	167.9	326.2	277.9	366.2	317.9	566.2	517.9
	9	14.8	139.8	91.5	214.8	166.5	324.8	276.5	364.8	316.5	564.8	516.5
	10	13.4	138.4	90.1	213.4	165.1	323.4	275.1	363.4	315.1	563.4	515.1
α	w	x	L _F	L _{F60}	L _F	L _{F60}	L _F	L _{F60}	L _F	L _{F60}	L _F	L _{F60}
60°	1	13.7	138.7	110.8	213.7	185.8	323.7	295.8	363.7	335.8	563.7	535.8
	2	12.5	137.5	109.6	212.5	184.6	322.5	294.6	362.5	334.6	562.5	534.6
	3	11.3	136.3	108.5	211.3	183.5	321.3	293.5	361.3	333.5	561.3	533.5
	4	10.2	135.2	107.3	210.2	182.3	320.2	292.3	360.2	332.3	560.2	532.3
	5	9.0	134.0	106.1	209.0	181.1	319.0	291.1	359.0	331.1	559.0	531.1
	6	7.9	132.9	105.0	207.9	180.0	317.9	290.0	357.9	330.0	557.9	530.0
	7	6.7	131.7	103.8	206.7	178.8	316.7	288.8	356.7	328.8	556.7	528.8
	8	5.6	130.6	102.7	205.6	177.7	315.6	287.7	355.6	327.7	555.6	527.7
	9	4.4	129.4	101.5	204.4	176.5	314.4	286.5	354.4	326.5	554.4	526.5
	10	3.3	128.3	100.4	203.3	175.4	313.3	285.4	353.3	325.4	553.3	525.4

Matching flanges with tube can be provided by SICK on request (please specify with order). Alternatively, a tube piece with premounted flanges can be ordered from SICK.

A tube with suitable diameter can be used to align the flange tubes for face-to-face mounting.

After welding, determine and note measure F-F (→ p. 63, Fig. 37) for later parameter setting.

3.2.2 Installing the control unit MCU

The control unit must be mounted on a level base at an accessible, protected location as shown in Fig. 39. The following must be taken into account:

- Maintain the ambient temperature range in accordance with the Technical Data under consideration of possible radiant heat (shield when necessary).
- Protect the unit from direct sunlight.
- Select an installation location free from vibrations when possible and stabilize vibrations when necessary.
- Provide sufficient clearance for cables and opening the front panel.

Providing suitable cables are used (see Section → p. 97, 3.3.6), the MCU-N control unit (version without integrated blower) can be installed up to 1000 meters from the sender/receiver unit (use bus lines in accordance with Fig. 3.3.8; length is the overall length of all cables). For easier access to the MCU, we recommend installing it in a control room (measuring station or similar). This facilitates communication with the FLOWSIC100 for configuration or troubleshooting.

If the device is to be installed outdoors, a weatherproof cover for the control unit or equivalent cover (corrugated roof) must be provided onsite.

Assembly dimensions

Fig. 39

MCU assembly dimensions

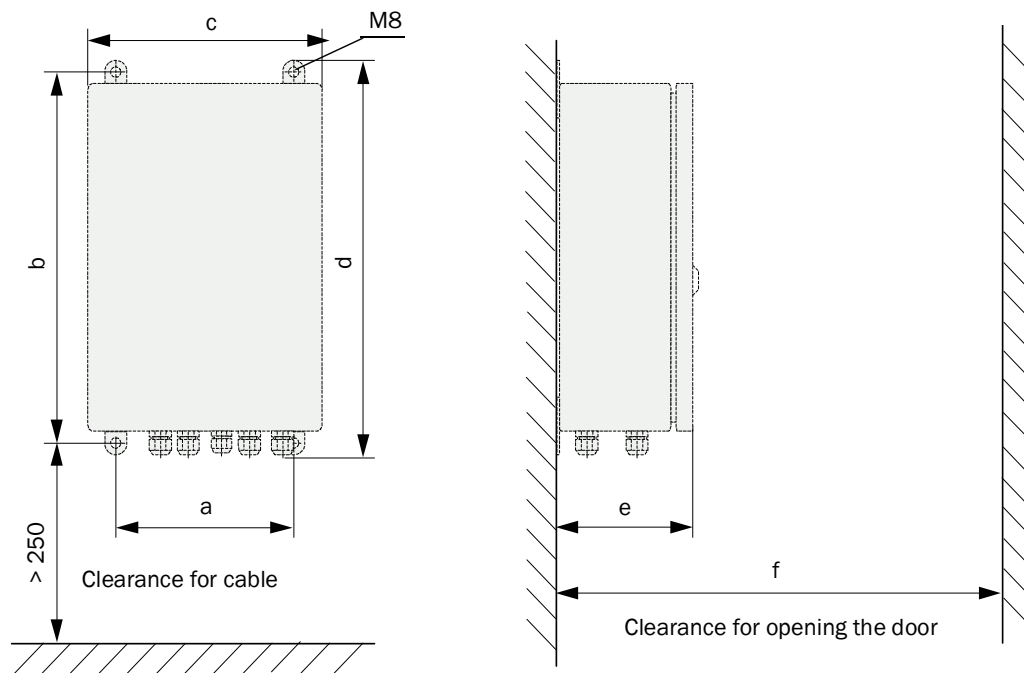

Measure	Connection unit type	
	MCU-N	MCU-P
a	160	260
b	320	420
c	210	300
d	340	440
e	125	220
f	> 350	> 540

MCU-N: Control unit without cooling air supply
 MCU-P: Control unit with cooling air supply
 (→ p. 176, 6.3.3)

Subject to change without notice

Prerequisite for using the control unit MCU-P (for FLSE100-MAC and HAC)

Additionally to the general requirements the following prerequisites apply:

- Install the MCU-P at a location with clean air whenever possible. The intake temperature must match the values specified in the Technical Data (→ p. 166, 6.1). If necessary, lay an air intake hose at a location where conditions are more favorable.
- The purge air hoses DN25 (Part No. 7047535 and 7047536) to both sender/receiver units should be as short as possible. They must be of equal length (max. hose length in each case 10 m).
- The purge air hoses should be laid in such a way that water cannot collect.

Additional requirements when the control unit MCU must be installed more than 10 m away from the measuring point:

- Use of a separate cooling air unit in the junction box (dimensions and assembly dimensions as for MCU-P; Part No. 2070816 and 2070817)
- Use of the control unit in version MCU-N (without integrated blower unit)

3.2.3 Installing the junction box

Install these subassemblies on a level base plate (secure with 2 M4x20 bolts).

Fig. 40 Junction box assembly dimensions

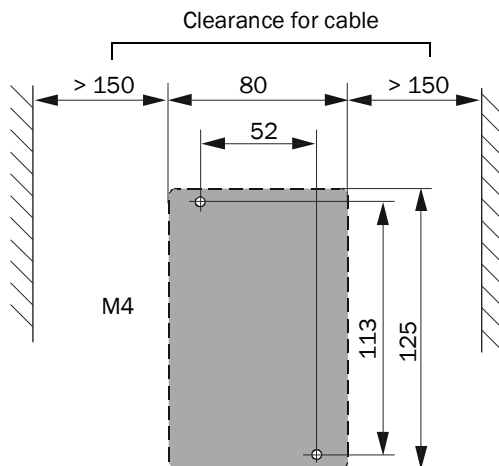

Suitable fastening sets are available for installation on stone / concrete ducts.

3.2.4 Installing the sender/receiver units

Check the following points before installing the sender/receiver units in the prepared flange tubes:

- Connections and sender/receiver units must be compatible (→ p. 28, 2.3.2).
- The inside walls of the connections must be completely free from welding beads.
- Optional: Fitting an impact protector on the sender/receiver unit (→ p. 72, 3.2.8)

Push the sender/receiver units into the flange tubes and fit these on the flange with the delivered bolts and the optional solid-borne noise damping set.

3.2.5

Installation of the weatherproof cover for the sender/receiver units

- ▶ Fix the holder to the sender/receiver unit:
 - Use the fixing accessories to attach the holder with round steel bow to the probe neck of the FLSE100
 - Pay attention to the correct alignment of the holder. See adjacent figure.

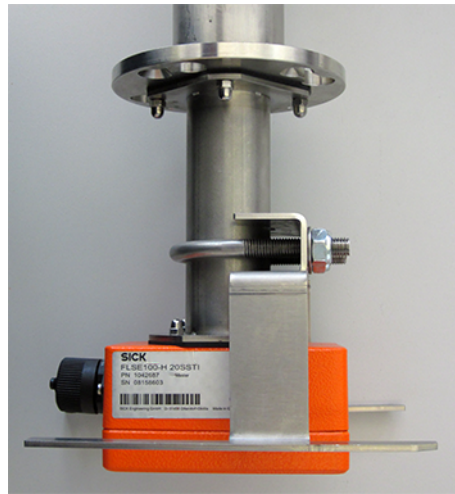
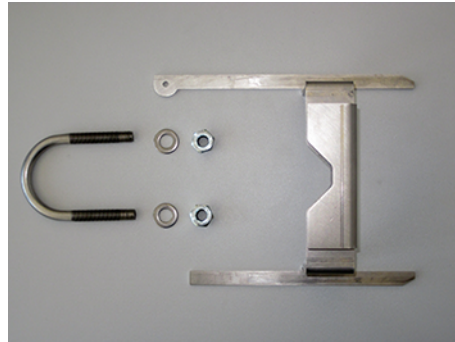

- ▶ Position the protective hood on the holder.

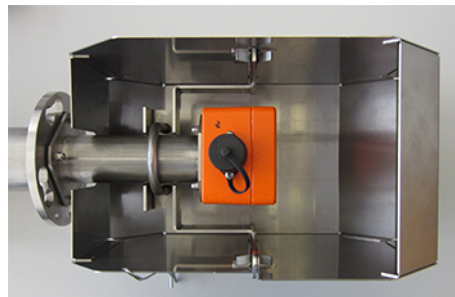

- ▶ Secure the weatherproof cover with the split pin.

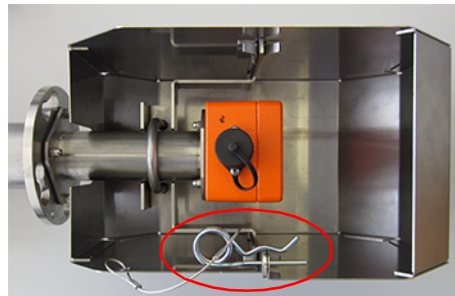

Subject to change without notice

3.2.6

Installing the purge air unit accessory (device types PM, PH, PH-S)

The steps below are only necessary when purged sender/receiver units are required.

The following points must be taken into account when selecting the installation location:

- The purge air unit must be installed in a location with clean air. The intake temperature must match the values specified in the Technical Data (→ p. 166, 6.1). If necessary, lay an air intake hose at a location where conditions are more favorable.
- The fitting location must be easily accessible and meet all applicable safety requirements.
- The purge air unit must be mounted as far below the sender/receiver units as necessary, so that the purge air hoses can be installed leading downwards to the purge air unit (avoiding water collection).
- Provide sufficient clearance for replacing the filter element.
- Provide sufficient clearance for fitting and raising the weatherproof cover when the purge air unit is installed outdoors (→ Fig. 41).

Fig. 41

Mounting the purge air unit

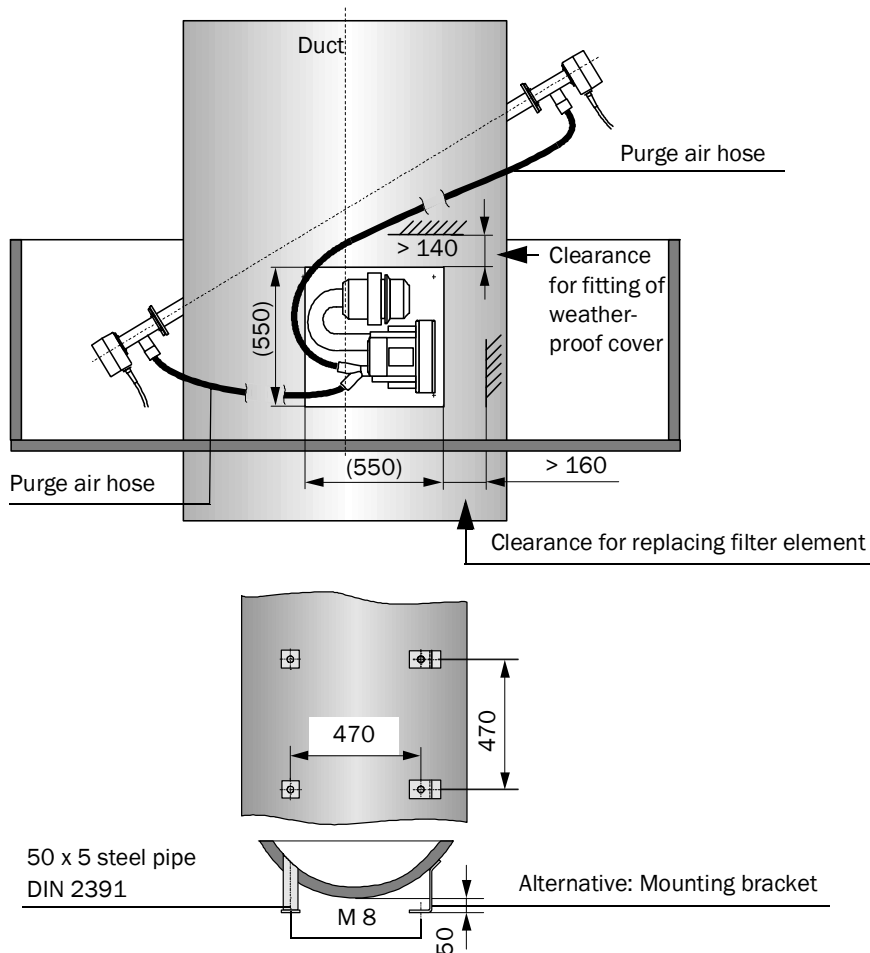

Subject to change without notice

Installation work

- ▶ Prepare the bracket in accordance with Fig. 41 (page 69).
- ▶ Secure the purge air unit with 4 bolts (M8).
- ▶ Check the filter element is in the filter housing, insert when necessary.

3.2.7 Installing the emergency air supply option for device types PM, PH and PH-S

The subassemblies are delivered pre-assembled.

- ▶ Connect adapters (3) to the purge air connections of the sender/receiver units and fasten with the hose clamps (scope of delivery) (→ Fig. 42).
- ▶ Fit and wire the solenoid valve on the purge air base plate (see connection → p. 93, 3.3.4.2, Fig. 66 - Fig. 68).
- ▶ Insert compressed air hoses (5) paired in quick-connectors (6) and fasten on quick connector (4). The compressed air hoses must always have the same length.

In case of a complete delivery from the factory, the compressed air hoses are installed to both sender/receiver units with a hose part of approx. 350 mm length.

Approx. 250 mm hose length is inserted into the sender/receiver units using the adapter (position 3 in → Fig. 42 und → Fig. 43), approx. 100 mm hose length is outside the sender/receiver units (→ Fig. 44).

The longer hose part of the compressed air hose is connected via a straight quick-connector. During disassembly of the sender/receiver unit, the compressed air hose can easily be loosened and re-attached using this connector.

Fig. 42 Connection - emergency air supply for one purge air unit

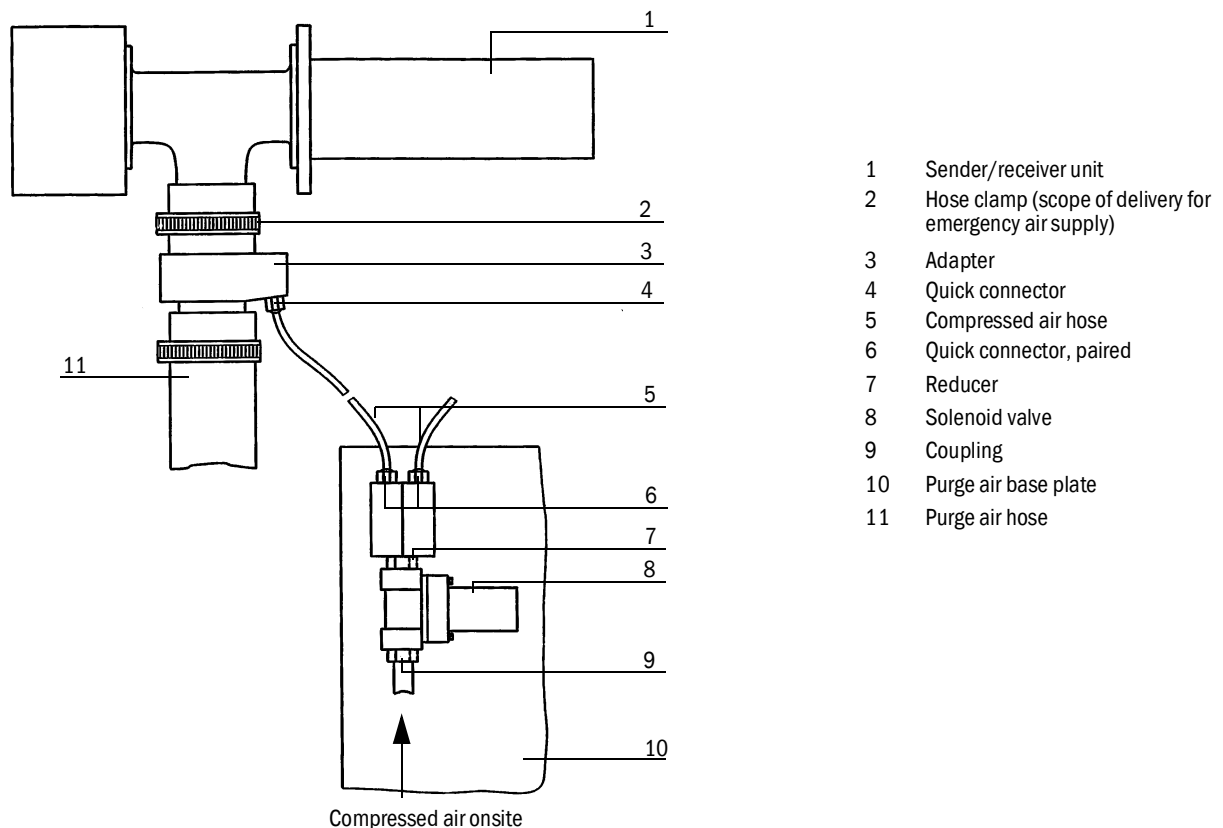

Subject to change without notice

Fig. 43 Connection - emergency air supply for two purge air units

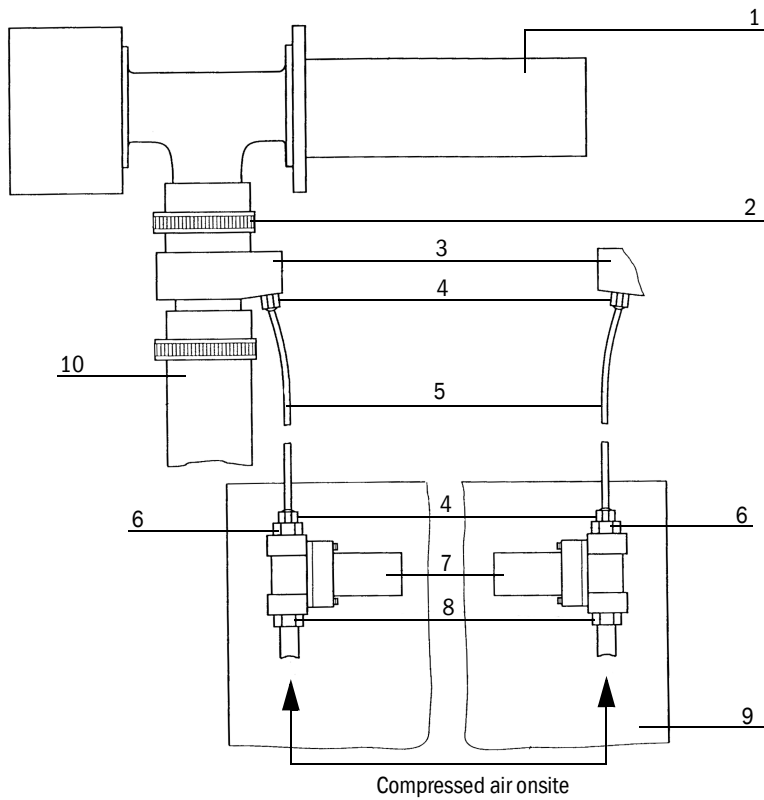

- 1 Sender/receiver unit
- 2 Hose clamp (scope of delivery for emergency air supply)
- 3 Adapter
- 4 Quick connector
- 5 Compressed air hose
- 6 Reducer
- 7 Solenoid valve
- 8 Coupling
- 9 Purge air base plate
- 10 Purge air hose

Fig. 44 Connection of compressed air hoses

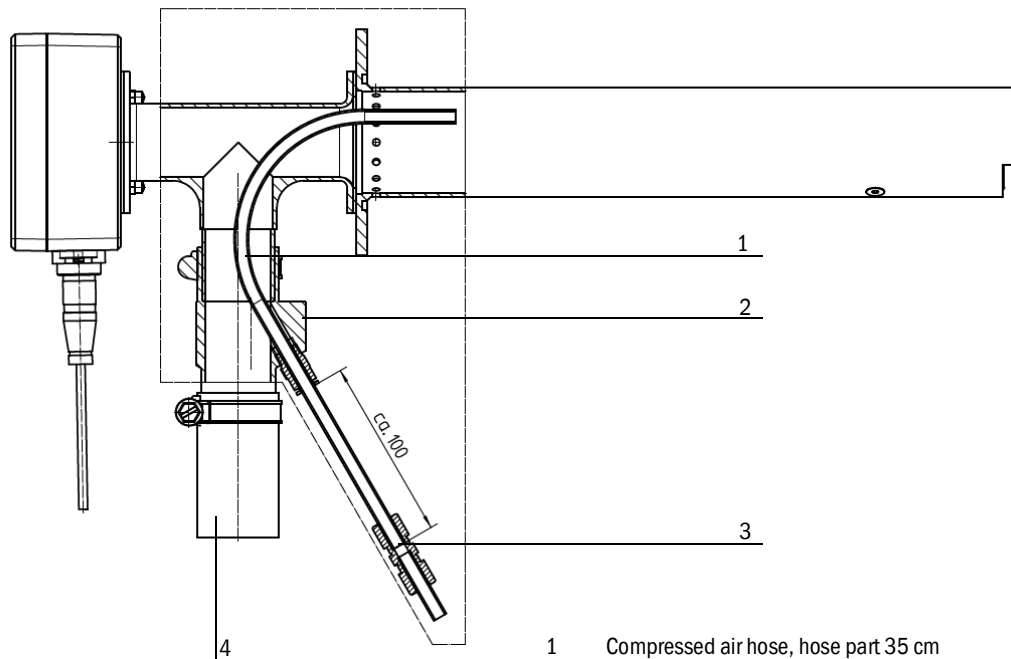

- 1 Compressed air hose, hose part 35 cm
- 2 Adapter
- 3 Quick-connector, straight
- 4 Purge air hose

Subject to change without notice

Insert the backflow valves (for overpressure in duct) directly on the Y-distributor of the purge air blower (remove the existing purge air hose) and fasten with hose clamps (Fig. 45).

Fig. 45 Fitting the backflow valve

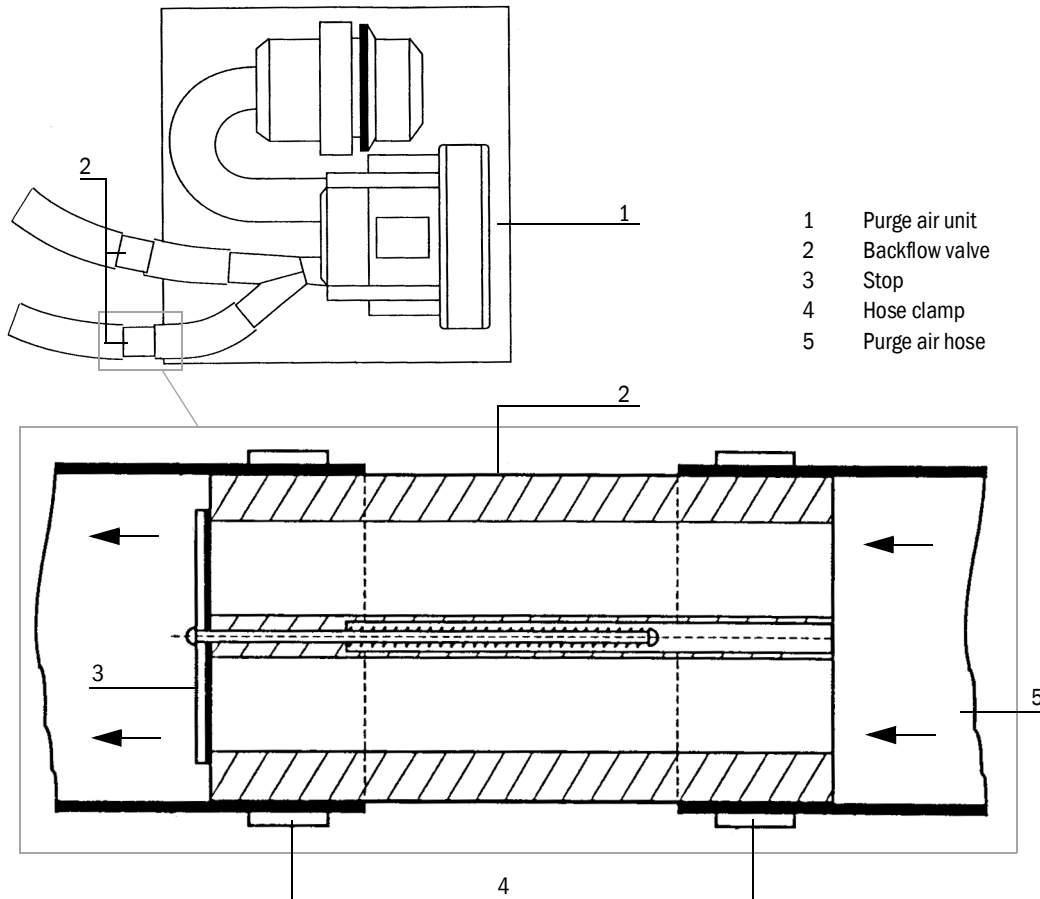

- 1 Purge air unit
- 2 Backflow valve
- 3 Stop
- 4 Hose clamp
- 5 Purge air hose

3.2.8 Installing the weatherproof cover for the purge air unit accessory

The weatherproof cover consists of a cover and lock set.

- ▶ Fit the lock parts from the lock set on the base plate.
- ▶ Fit the weatherproof cover from above.
- ▶ Insert the side lock bolts in the counterparts, rotate and latch into place.

3.2.9 **Installation of impact protector/dust protector option**

3.2.9.1 **Impact protection for FLSE100-H, HAC, PH and PHS**

The impact protector option is intended for the use of the FLOWSIC100 in high dust applications with particle sizes >0.5 mm. Installing this component provides effective protection for the surface of the ultrasonic transducer against particle impact.

It is normally sufficient to fit the impact protector on the downstream sender/receiver unit (probe B) (→ p. 15, Fig. 4).

Assembly

- ▶ Fit on types PH and PHS with the securing bolts of the transducers.

Installing the impact protector option for types PH and PHS

Fig. 46 Installing the impact protector option for types PH and PHS

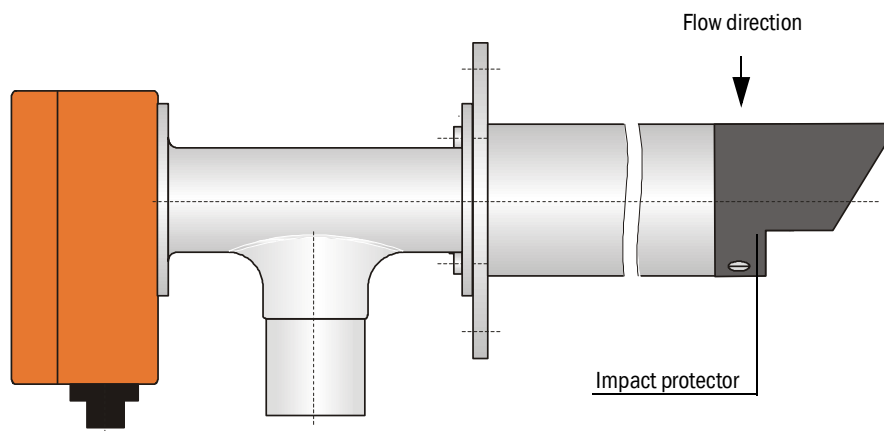

The impact protector is located on the probe head as shown in Fig. 46 and must be aligned facing the flow direction.

- ▶ Fit on type H to the securing holes provided on the probe head using the delivered securing bolts

Fig. 47 Installing the impact protector option for type H

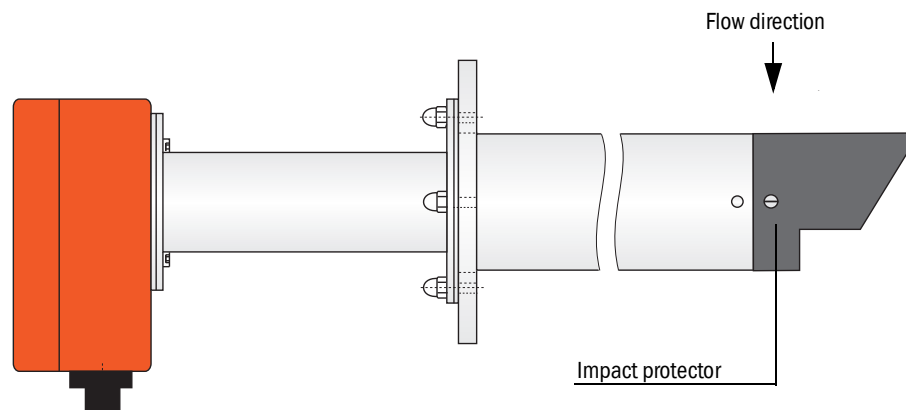

The impact protector is located on the probe head as shown in Fig. 47 and must be aligned facing the flow direction.

- ▶ Follow the following instructions for installing the impact protector for type HAC.

Installing the impact protector option for type HAC

- ▶ Fold the impact protector plate around the transducer and press the angled clips into the recesses on the opposite side of the plate.
- ▶ Keep folding the clips towards the folded edge until they touch the plate.

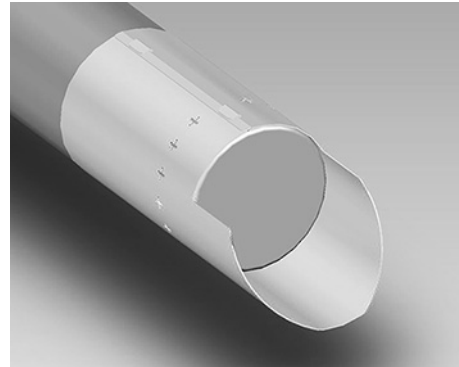
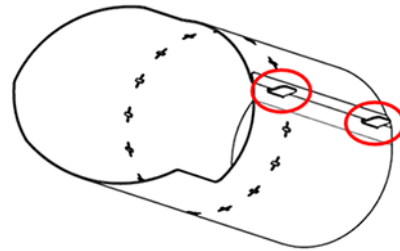

- ▶ Align the impact protector facing the flow direction and use a punch to drive the crosswise recesses into the four mounting holes of the transducer.

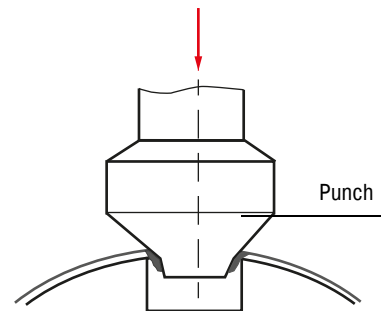

3.2.9.2 Dust protector for FLSE100-PR

The optionally available dust protector PR can be used when dust contamination on the transducer surface of the single-probe version FLSE100-PR causes a problem. This option is designed to prevent possible contamination of dust on the ultrasonic transducers. It comprises the components “right dust protector” and “left dust protector”. Fit the components to the downstream sides of the transducers in accordance with Fig. 48.

Fig. 48 Fitting of the dust protector option on type FLSE100-PR

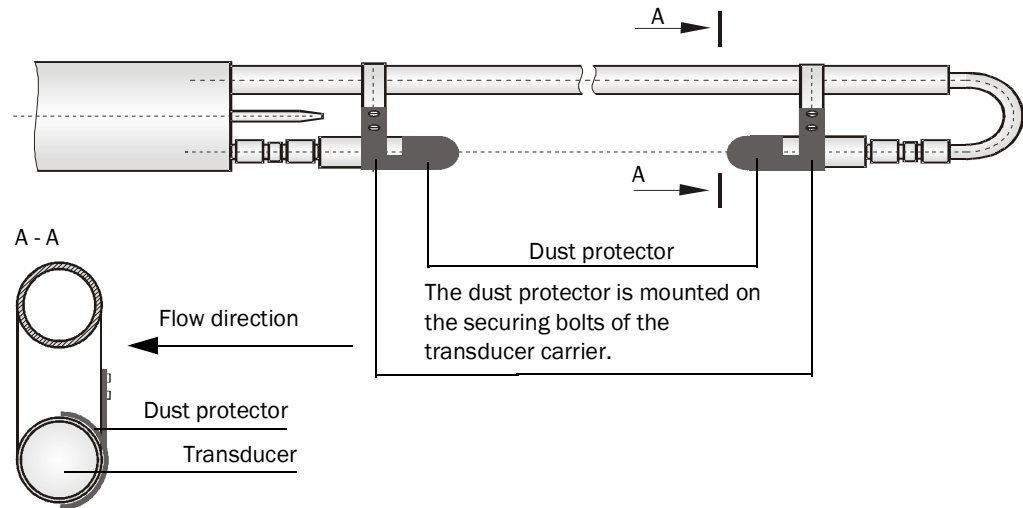

NOTICE:

The effectiveness of the dust protector depends on the dust texture and flow conditions in the duct and can therefore considerably vary.



3.2.10 Installation of solid-borne noise damping set option K100/K75

In some installations, vibrations in the resonance range of the ultrasonic transducer come from the system over the flange to the sender/receiver units and therefore have an effect on the transducer and create interference signals (direct acoustic coupling). The optional solid-borne noise damping set K100/K75 can be used to prevent such disturbances. It comprises additional gaskets, cup springs and washers as well as appropriate longer securing bolts, which are used for fitting the sender/receiver units.

A damping set is already included in the assembly material at the factory for device types M, H, M-AC and H-AC. The set serves to prevent coupling of solid-borne noise from the system in the ultrasonic transducer. The assembly/damping set is delivered as shown in Fig. 49 and is ready for installation.

Fig. 49

Damping sets

Designation	For type FLSE100	Part No.	Scope of delivery
Damping set K100	FLSE100-H, FLSE100-H-AC	2056565	
Damping set K75	FLSE100-M, FLSE100-MAC	2056564	



NOTICE:

A damping set, Part No. 2042503, is available for retrofitting on existing installations FLSE100-M, -H, -MAC and -HAC.

Fig. 50 Installing the assembly/damping set

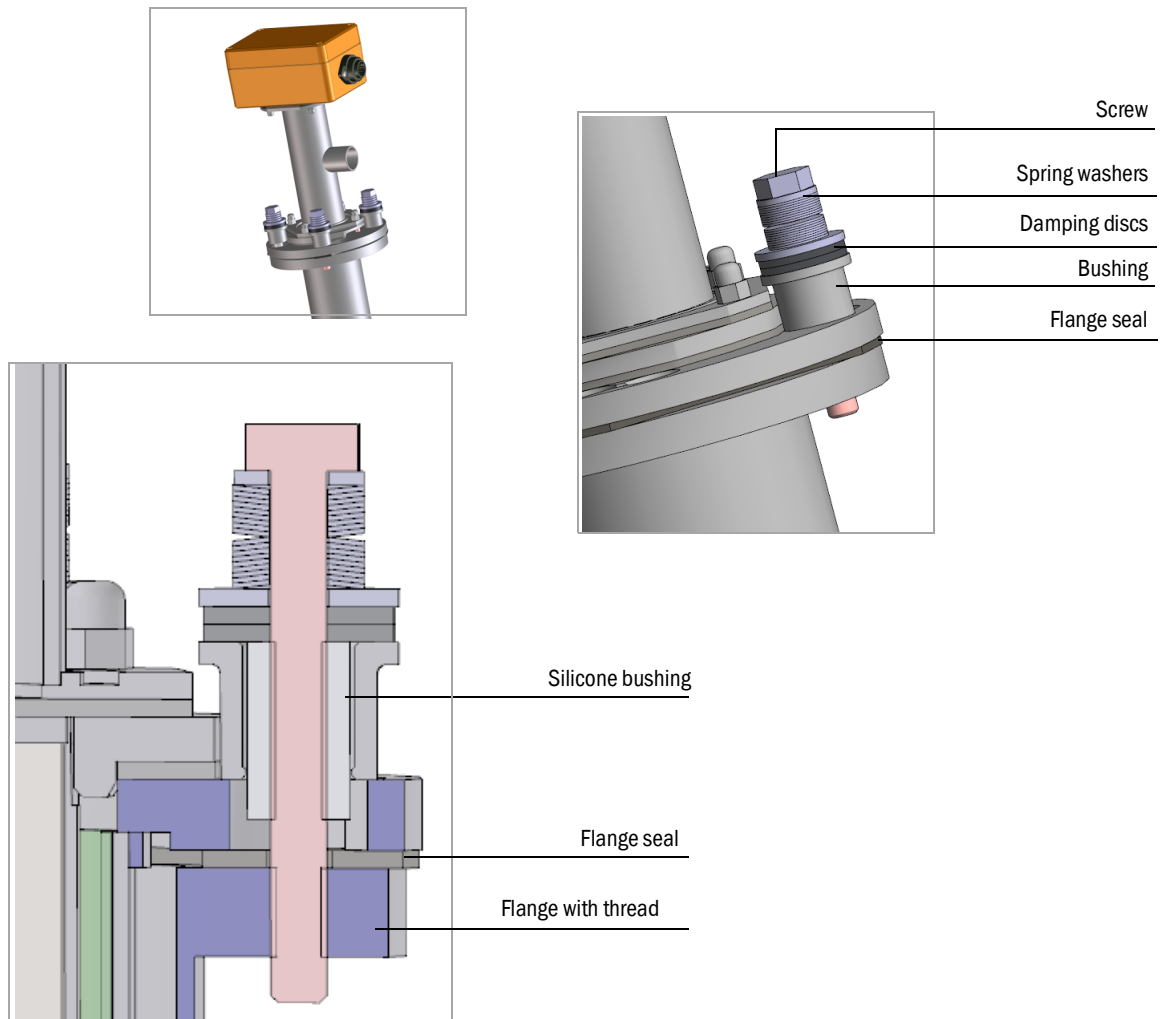

Installation instructions for solid-borne noise damping set option K100/K75

- ▶ Position the flange seal between the flange plates
- ▶ Fit the screws with all delivered parts in the flange (see Fig. 50)



NOTICE:

- ▶ Tighten the screws until the gap between the spring washer sets is no longer visible.
- ▶ Then loosen the screw by approx. ¼ turn until the gap between the spring washer sets is visible again to ensure full damping effect.



NOTICE:

Should interference signals occur although a solid-borne noise damping set is used, the additionally delivered flange seal can be installed to increase damping effect.

Subject to change without notice

3.3 Installation

3.3.1 General instructions, prerequisites

Carry out the steps described in → p. 60, 3.2 before starting installation work.

Unless otherwise agreed with SICK or an authorized representative, all of the installation work must be carried out by the plant operator. This includes:

- ▶ Laying all the power supply and signal cables
- ▶ Connecting the power supply and signal cables to the system components
- ▶ Installing the switches and mains fuses

Carry out the additional work described in Section § 3.3.2 when using the purge air unit accessory.



- ▶ Plan adequate line cross-sections (→ p. 166, 6.1 “Technical Data”)
- ▶ The cable ends with plug for connecting the sender/receiver units must be long enough.
- ▶ Cable connectors that are not connected must be protected from dirt and moisture (fit cover).



WARNING:

- All installation work must be carried out in line with the relevant safety regulations and instructions listed in Chapter 1.
- Suitable protective measures must be taken to protect against local or system-specific danger.

3.3.2 Installing the cooling air/purge air supply

The following steps are only necessary when internally cooled or purged sender/receiver units must be used.

- ▶ Lay the cooling air/purge air hoses on short routes and without kinks, shorten if necessary.
- ▶ Leave sufficient clearance to hot duct walls.
- ▶ Ensure cooling air can escape freely when installing on isolated ducts (device types M-AC and H-AC) (→ p. 25, Fig. 11, Fig. 2.3.1.3)

3.3.2.1 Control unit MCU-P with integrated cooling air supply (devices types M-AC and H-AC)

- ▶ Connect the power cable to terminals L1, N and PE on the terminal strip.
- ▶ Connect the DN 25 cooling air hose to the cooling air outlet on the underside of the MCU-P (→ p. 79, Fig. 51) and secure it with a strap retainer. The purge air outlet in the middle must be adjusted as displayed (correct if necessary).

Fig. 51

Underside of control unit with integrated cooling air supply

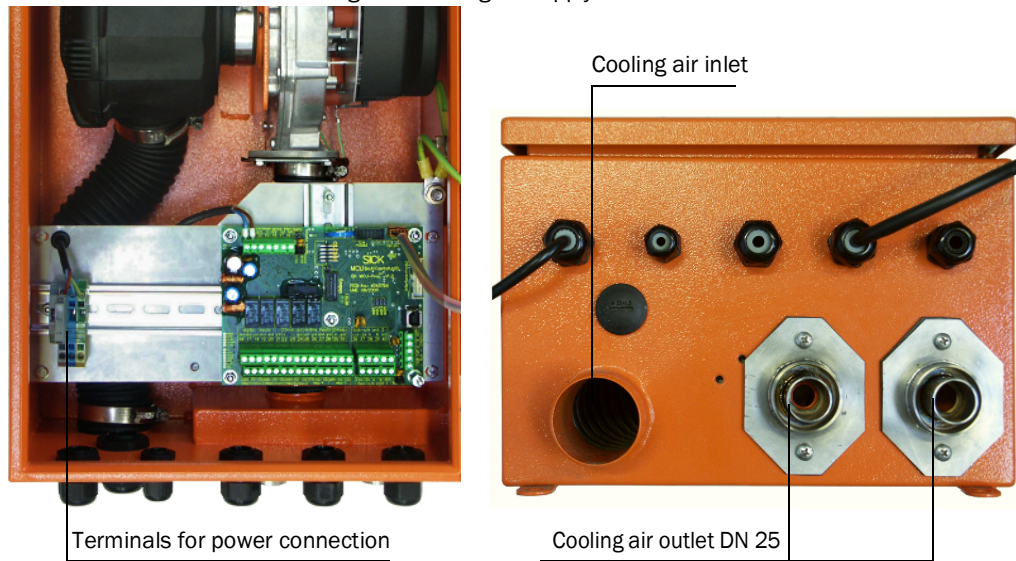

3.3.2.2

Separate cooling air supply in junction box (device types M-AC and H-AC)

- ▶ Connect the power cable to terminals L1, N and PE on the terminal strip.
- ▶ Connect the DN 40 cooling air hose to the cooling air outlet on the underside of the junction box (→ Fig.) and secure it with a strap retainer. The cooling air outlet in the middle must be adjusted as displayed (correct if necessary).



NOTICE:

Same cooling air connections for use of separate cooling air supply in the control box (→ Fig. 51).

3.3.2.3

Purge air unit (device types PM, PH, PH-S)

- ▶ Compare the power voltage and frequency with those specified on the type plate of the purge air motor.

NOTICE:
Do not connect the purge air unit if the values do not match.

- ▶ Connect the power supply cable to the terminals on the purge air motor (see supplementary sheet on purge air motor and cover of motor terminal box; connection arrangement → Fig. 52).
- ▶ Connect a protective conductor to the terminal.
- ▶ Set the motor circuit breaker in accordance with the connection data of the blower (see technical data of purge air unit) to a value 10% greater than the rated current.
- ▶ Check the functioning and running direction of the blower (flow direction of the purge air unit must match the arrows on the inlet and outlet openings on the blower). Incorrect running direction on 3-phase motors: Swap power connections L1 and L2.
- ▶ Connect the (optional) pressure controller for monitoring the purge air supply.

NOTICE:

- ▶ Use a fail-safe power supply (emergency voltage supply, bar with redundant supply)
- ▶ The purge air unit must be fused separately from the other system components. The fuse type must match the rated current (see technical details of purge air unit). Fuse each phase separately. Provide circuit breakers to protect against a phase failure on one side.

In case of doubt or when using a special motor version, the operating instructions supplied with the motor have priority over any other information.

Fig. 52 Electrical connections for the purge air unit accessory

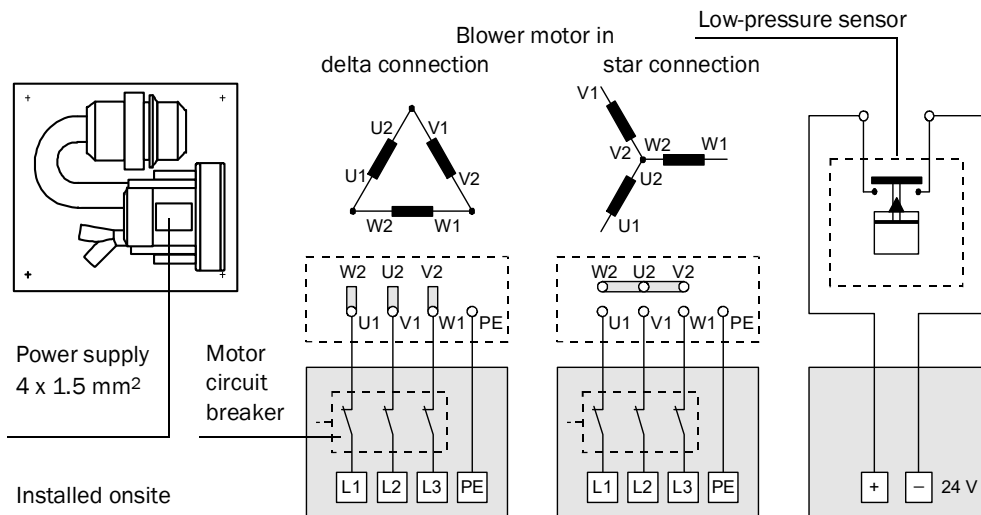

3.3.2.4 Installing the purge air and cooling air reducer option

If necessary, install a purge air reducer for FLOWSIC100 PM, PH, PHS or a cooling air reducer for FLOWSIC100 MAC, HAC according to → Fig. 53.

Fig. 53

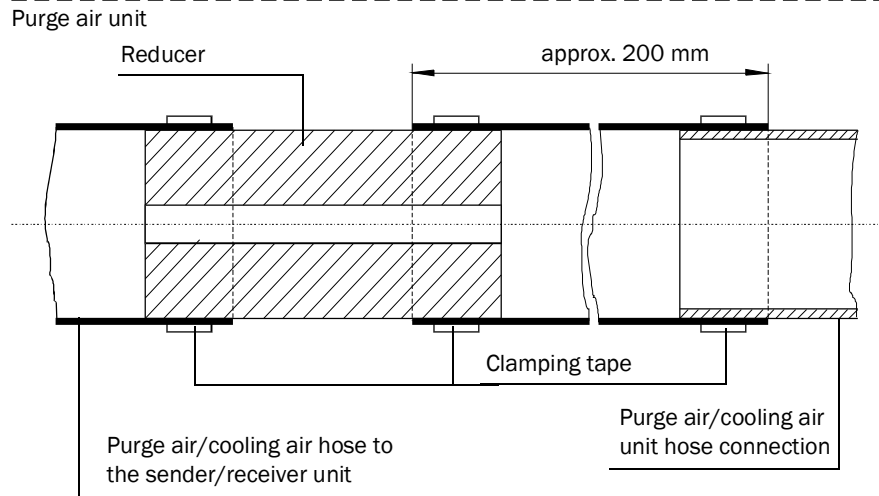

NOTICE: Cooling air reducer for FLOWSIC100 MAC, HAC

- ▶ Usually, it is not necessary to install the reducing pieces during regular operation.
- ▶ Installation can become necessary when the measuring system runs in an extreme range due to unfavorable application conditions and noise effects of the cooling air have to be reduced.
- ▶ In particular cases, the effectiveness of the cooling air reducer has to be checked by a trained service technician during start-up of the measuring system.

3.3.3

Installing the cooling air control option for device types M-AC and H-AC

- a) System configuration with control unit MCU-P (with integrated blower unit)
System configuration with control unit MCU-N + cooling air supply 24 V DC in junction box
- ▶ Snap the solid-state relay into place on the MCU top hat rail.
 - ▶ Disconnect the blue lead of the connection to the cooling air blower from MCU terminal 47 and connect it to the white lead of the solid-state relay (from relay terminal +13) using a lamp-wire connector.
 - ▶ Connect the brown lead of the solid-state relay (relay terminal 14) to MCU terminal 47 (gnd blower).
 - ▶ Connect MCU terminal 13 (com limit) and terminal 30 (gnd) with a black jumper.
 - ▶ Connect terminal A2 (-) of the solid-state relay to MCU terminal 15 (n.o. limit).
 - ▶ Connect terminal A1 (+) of the solid-state relay to MCU terminal 29 (+ 24 V DC)
- See terminal connection diagram → p. 85, Fig. 56

- b) System configuration with control unit MCU-N + cooling air supply 230 V AC in junction box
Same connection as the configuration in a) but with the following change:
- Connect terminals 13 and 14 of the solid-state relay to the power supply 24 V DC for the external blower unit.

See terminal connection diagram → p. 86, Fig. 57

**NOTICE:**

The colors of the leads between the solid-state relay and MCU only serve as examples and can vary depending on the delivery

Fig. 54 Electrical connection of the cooling air control option for the MCU-N + cooling air supply 24 V DC in junction box

Connection terminal:
L1: +24 V
L2: gnd

Solid-state relay

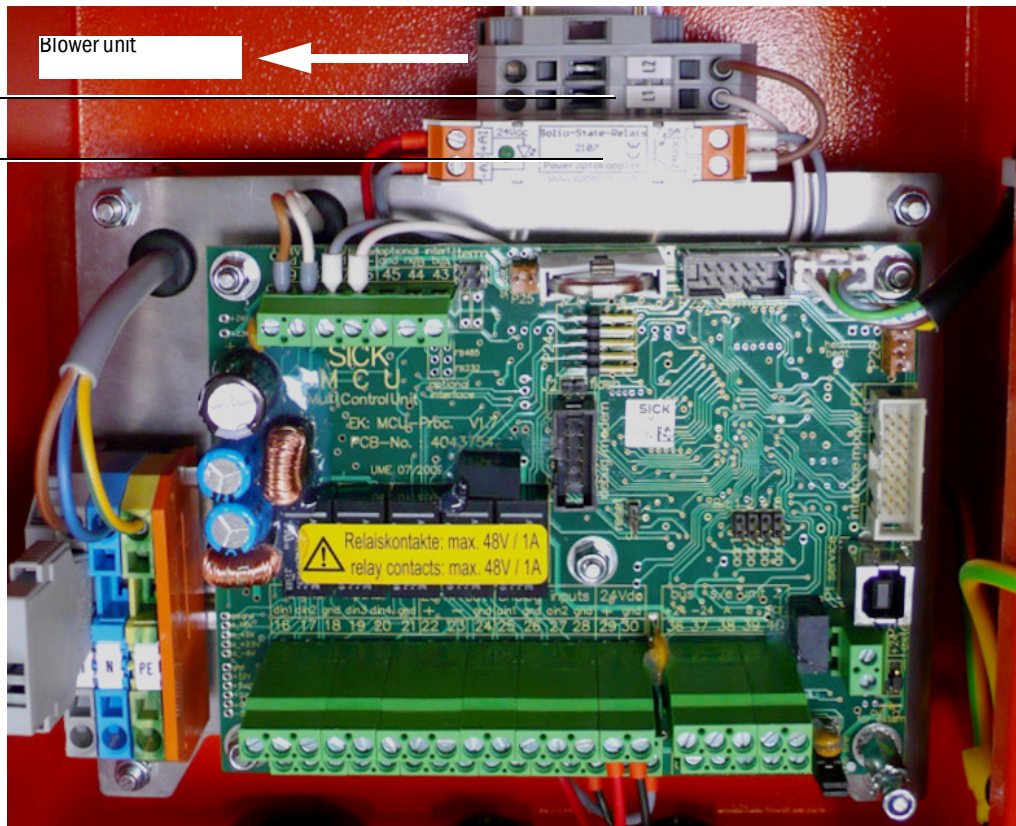

NOTICE:

The solid-state relay is installed in the cooling air supply housing on systems with cooling air supply 230 V AC in junction box.

Fig. 55

Electrical connection of the cooling air control option for the MCU-P with integrated blower unit

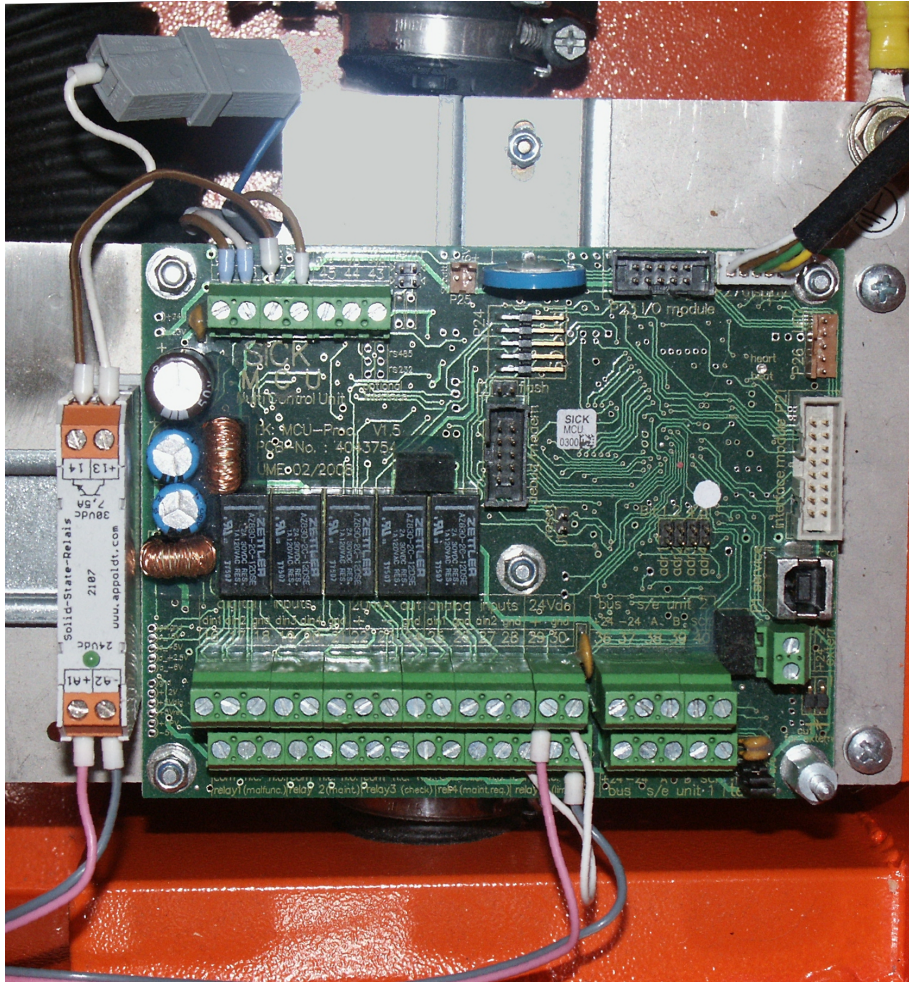
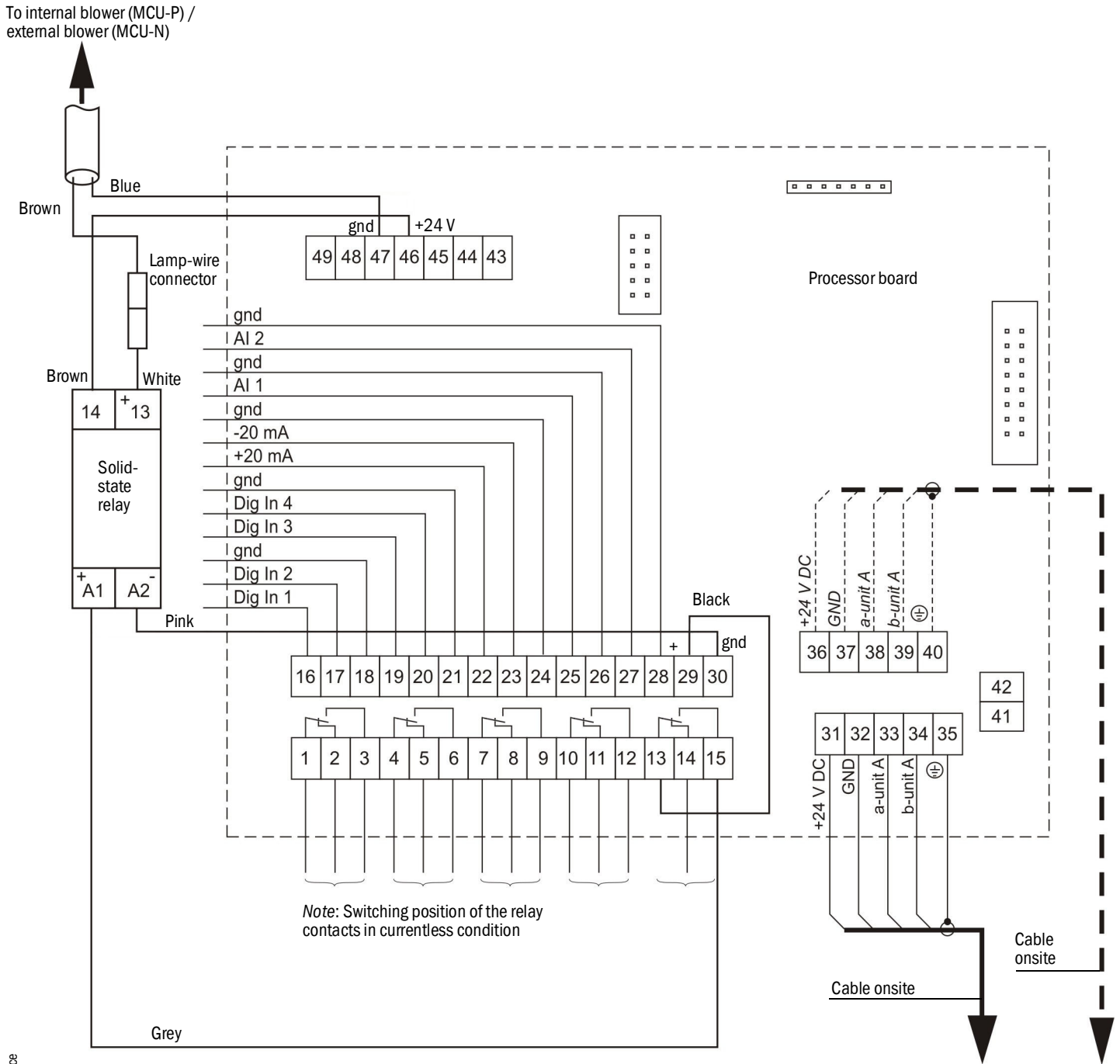

Fig. 56

Connection between cooling air control on MCU-P and MCU-N with external blower unit 24 V DC



Subject to change without notice

Cable specification for the power supply of the external blower unit in junction box

The following demands with regard to wire cross-sectional area and specific resistance must be considered for the supply cable to ensure the power supply for the external blower unit.

Wire cross-sectional area mm ²	Specific resistance in Ω/km	Max. cable length in m
0.5	40	25
0.75	25	40
1.00	18	55
1.5	14	70
2.5	8	130

A separate power supply is required for the blower unit for distances greater than 130 m between the MCU-N and external blower unit. In this case, use the cooling air supply in junction box with connection 230 V AC.

Fig. 57

Connection of the cooling air control option when using MCU-N 230 V AC with external blower unit 24 V DC

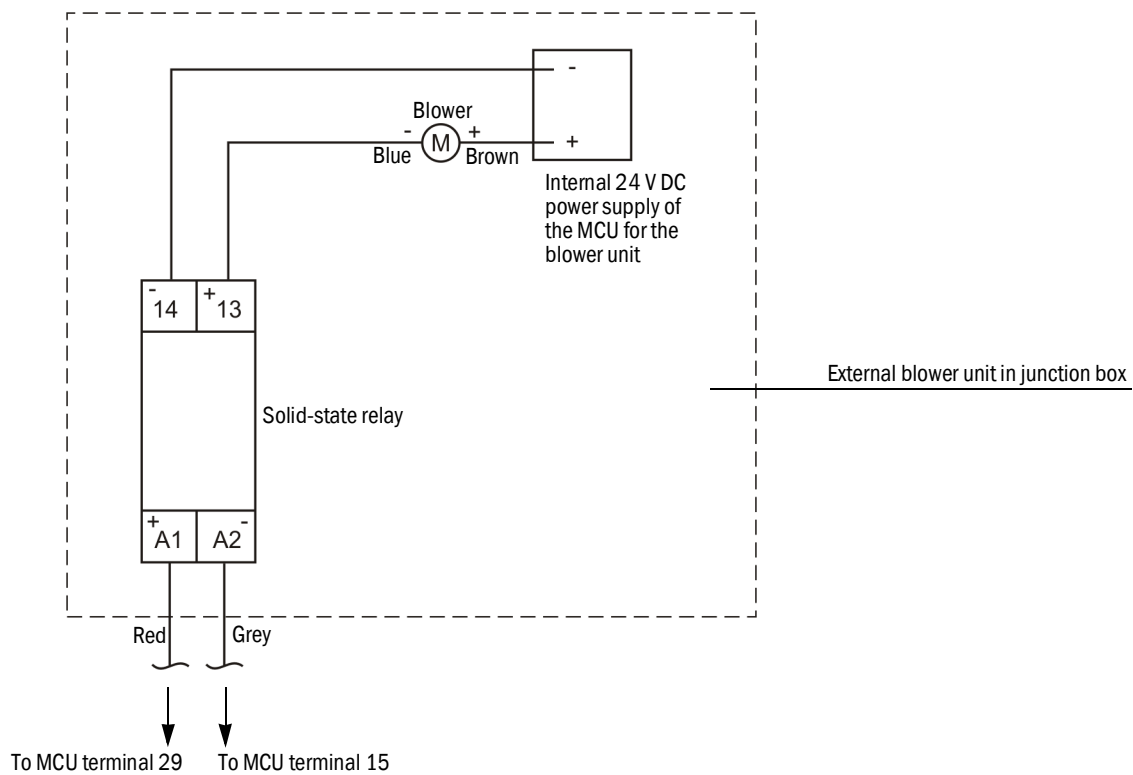

3.3.4 **Installing optional sets for emergency air supply for devices with cooling air/ purge air operation**

3.3.4.1 **Emergency air supply for device types M-AC and H-AC**

The “emergency air supply FLOWSIC100 M-AC and H-AC” is delivered pre-assembled in its subassemblies. (→ p. 87, Fig. 58)

Fig. 58 Primary pressure set and resulting cooling air volume flow

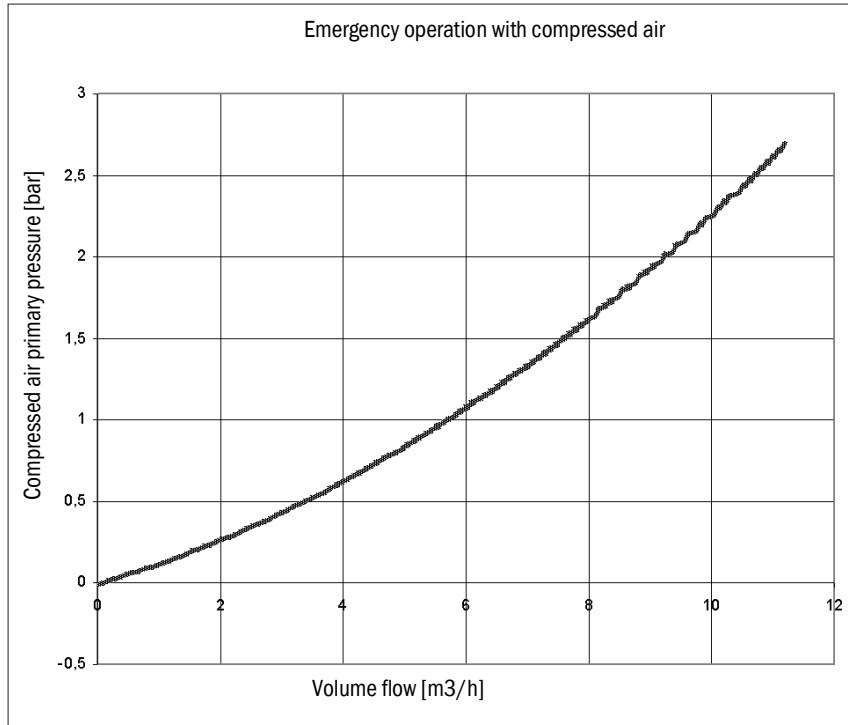
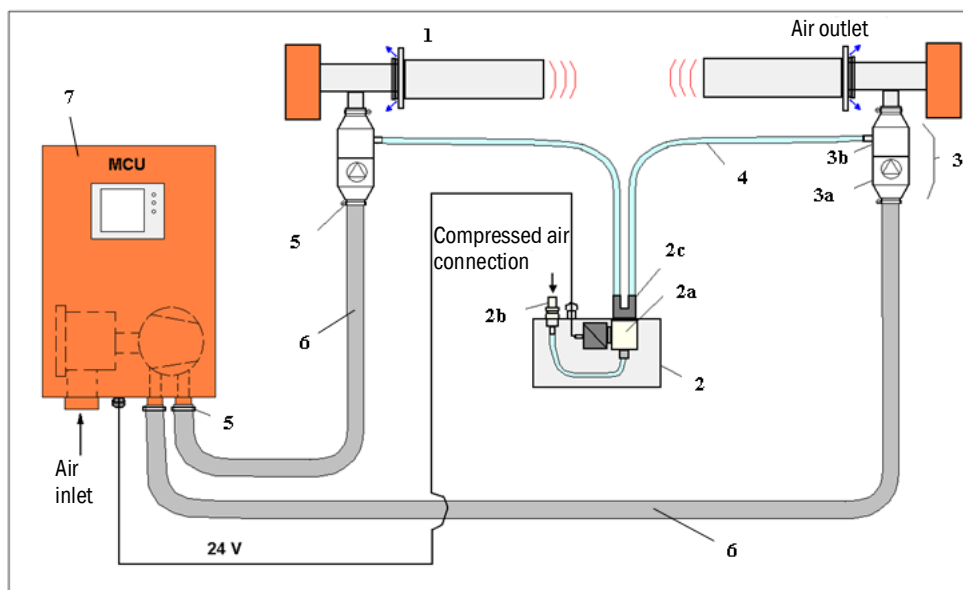

Fig. 59 Layout and functional diagram of cooling air supply with emergency air option



Subject to change without notice

Table 1 Standard components

1	FLSE100-HAC or MAC	Standard component
5	Hose clamp	Standard component
6	Flexible cooling air hose	Standard component
7	MCU-P with integrated blower unit	Standard component

Table 2 Components for the emergency air supply option M-AC, H-AC

2	Junction box for solenoid valve a) Solenoid valve b) Connection plug c) Y adapter
3	Emergency air valve a) Backflow valve DN25 b) Screw fitting
4	Emergency air line (instrument air)

Connect emergency air valves (3) between flexible DN 25 cooling air hoses (6) and the cooling air inlet of the S/R units using hose clamps (5). The different connection diameters determine the assembly direction (in flow direction) of emergency air valves (3).

Connect emergency air lines (4) (switched compressed air) via quick-connectors to Y branch (2c) on junction box solenoid valve (2) and screw fittings (3b) on emergency air valves (3). Connect the compressed air supply (instrument air free from oil, grease and water) via connection plug (2b).

Arrange the MCU (7), S/R units, supply lines and junction box solenoid valve so that both flexible DN25 cooling air hoses(6) from the MCU blower unit and emergency air lines (4) from junction box solenoid valve (2) to both S/R units have the same length (same pressure loss, same amount of cooling air on FLSE100 A and B).

Electrical installation

Fig. 60

Solenoid valve electrical connection

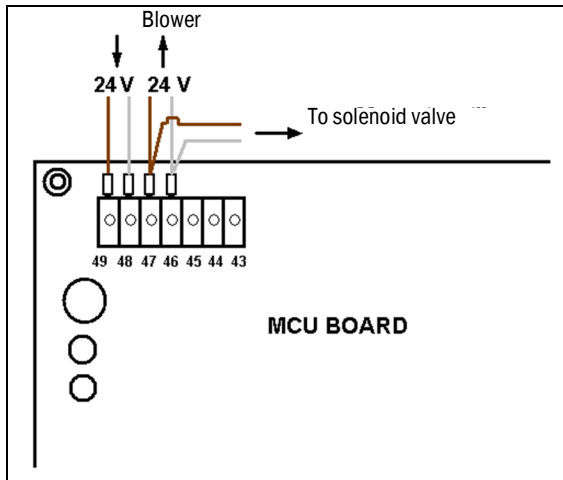

Make a 2-wire connection to the solenoid valve (blade terminal). There are no requirements on polarity because the pulling magnet is electrically isolated from the valve body.

Pulling magnet connection values: 24 V DC; 0.43 A continuous current.

Function test in normal operation with MCU blower unit

a) Start the blower by switching the MCU on.

When using the optionally available “cooling air control for device types M-AC and H-AC”, start blower operation in a suitable manner; e.g. with a fixed blower connection on the 24 V rail or bridging the relay.

b) Remove the emergency air valves (→ p. 89, Fig. 61) and start the MCU blower.

The blowing air flow must lift the valve plate evenly approx. 2 mm out of its seating and the cooling air flow passing through must be clearly felt. When necessary, close off the other line.

Lift the valve plate mechanically when the valve sticks in its seating (long storage time). Then repeat the test to ensure the blower can open the valve on its own.

Fig. 61

Removing and throughflow test on the emergency air valves

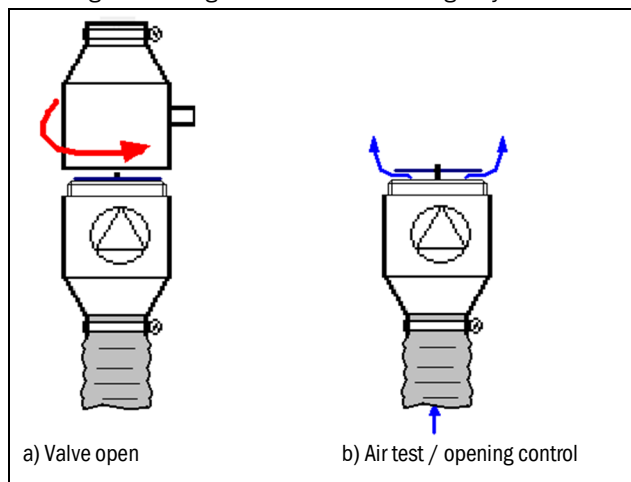

Subject to change without notice

Function test emergency air operation with instrument air

- ▶ Make a compressed air connection between the junction box for solenoid valve (2) and emergency air valve (3) as shown in (→ p. 87, Fig. 59).
- ▶ Separate the emergency air valve from the cooling air hoses and S/R units.
- ▶ Switch the MCU supply voltage off - solenoid valve (2a) must switch audibly and release the instrument air flow.
- ▶ Emergency air flow direction test - see (→ Fig. 62).

Fig. 62

Emergency air direction test

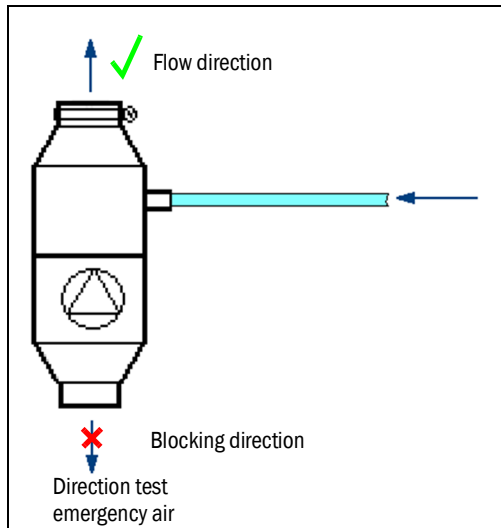

The air flow in flow direction must be noticeable (approx. 2.8 l/s). No significant leakage flow should flow in the blocking direction (→ Fig. 62). Leakage rates up to 3% of the nominal air flow are allowed.

Repeat the test shown in Fig. 62 with the S/R unit connected (→ p. 87, Fig. 59). The escaping air should still also be clearly felt on the probe exhaust slots (→ p. 87, Fig. 59).

- ▶ Finally, reconnect all connections as shown in (→ p. 87, Fig. 59), reset any changed parameters and set the device to the operating state.

Maintenance

The emergency air supply should be able to bridge temporary cooling air failures up to 24 hours. Measuring operation could be interrupted during this time (noise disturbance due to increased instrument air noise).

It is recommended to take the S/R units out of the sample gas duct during longer term restrictions or complete failure of the standard cooling air supply.

Check parts carrying air as shown in (→ p. 87, Fig. 59) after longer emergency air operation:

- ▶ Remove the DN 25 cooling air hoses and check the insides for condensate, oil and general contamination. Clean the insides of the hoses when necessary and replace hoses with heavy contamination. Use hoses with the same length for both S/R units.
- ▶ Remove the emergency air valves and open to check (→ p. 89, Fig. 61).
- ▶ Remove any contamination and dry the valve, replace emergency air valve (3) when contamination is heavy or when the valve is damaged (spring, valve plate, rubber seal).
- ▶ Apply talcum powder to the dry rubber seal of the valve plate to prevent the valve plate sticking in the seating.
- ▶ Carry out the opening and blocking direction function check as shown in (→ p. 90, Fig. 62).

- ▶ Remove the DN25 cooling air hoses from the MCU outlet and check the MCU outlet for any moisture inside (possibly from compressed air, leakage flow).
- ▶ Open the air filter housing in the MCU and check the paper filter element.
- ▶ Replace the filter element when penetrated by moisture or extremely contaminated - air filter replacement - analog OI Section 5.3.

Solenoid valve maintenance/repairs

- ▶ Open the junction box for the solenoid valve.



WARNING:

The solenoid valve surface can be hot (> 70 °C).

- ▶ Test switch the solenoid valve with varying compressed air primary pressures (1...3 bar).
- ▶ Should valve switching fail, use central screw (1) (→ p. 91, Fig. 63) on the solenoid switch to open the valve.
- ▶ Screw the tension rod out above hexagon (2) (→ p. 91, Fig. 63).

Fig. 63

Opening the solenoid valve

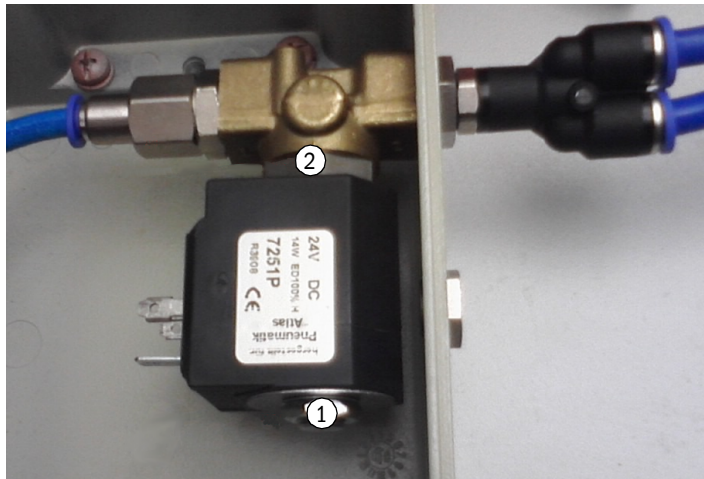

- 1. Solenoid valve central screw
- 2. Hexagonal solenoid valve

The valve seating is now open (→ Fig. 64) and can be cleaned when necessary.



WARNING:

Do not use any sharp objects.

Fig. 64

Valve seating / sealing surface in solenoid valve



Replace the complete solenoid valve when heavily contaminated and/or corroded.

Fig. 65

Solenoid valve, electrical part; pulling magnet with anchor / sealing punch

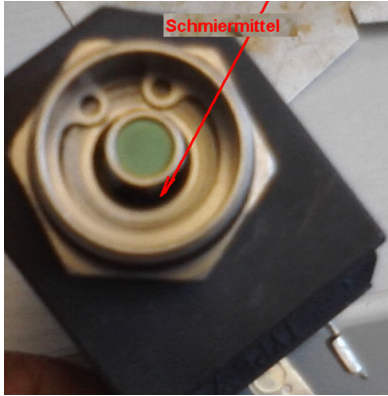

Spray a little spray oil in the ring gap (→ Fig. 65) when the anchor in the pulling magnet is sluggish (switching test when removed) → Fig. 65).

Parts overview

Part No.	Description
2051484	Emergency air supply 24V for MCU

3.3.4.2 **Emergency air supply for device types PM, PH and PHS**

Fig. 66 Connection for operating voltage 230 V AC

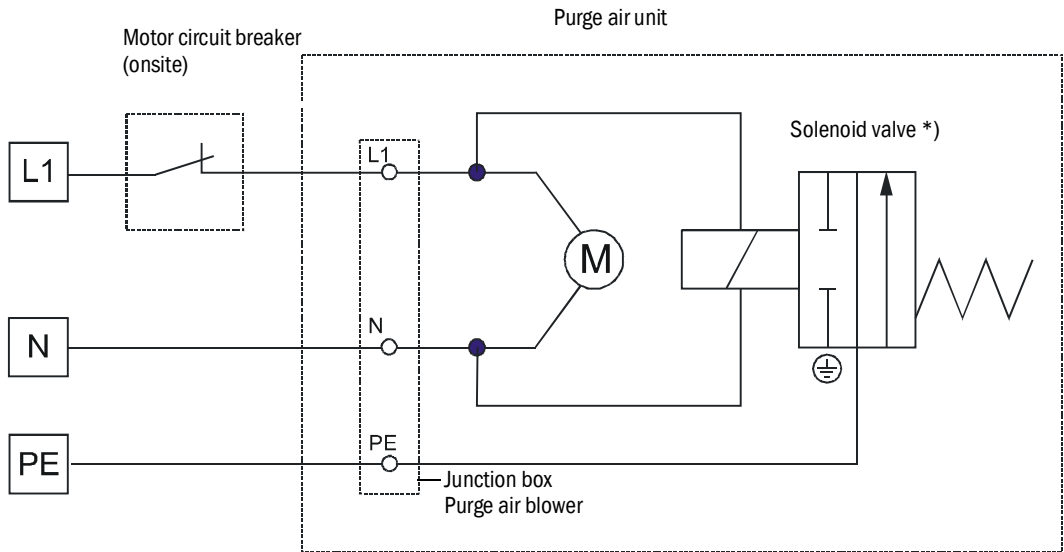

*) In SICK scope of delivery but not fitted

Fig. 67 Connection for operating voltage 380 V AC (without phase sensor)

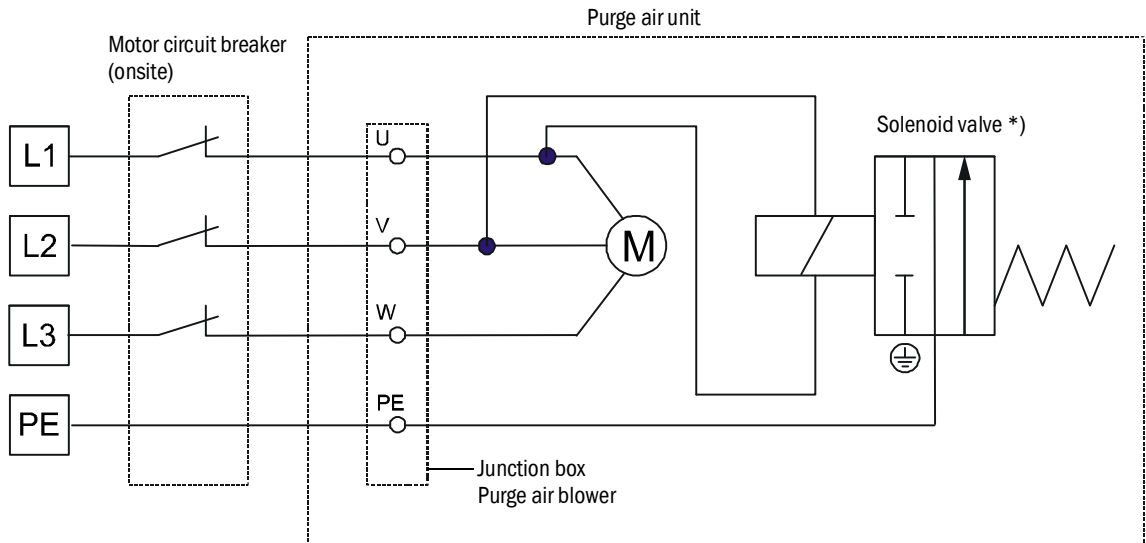

*) In SICK scope of delivery but not fitted

Fig. 68 Connection for operating voltage 380 V AC with phase sensor for monitoring failure of any phase

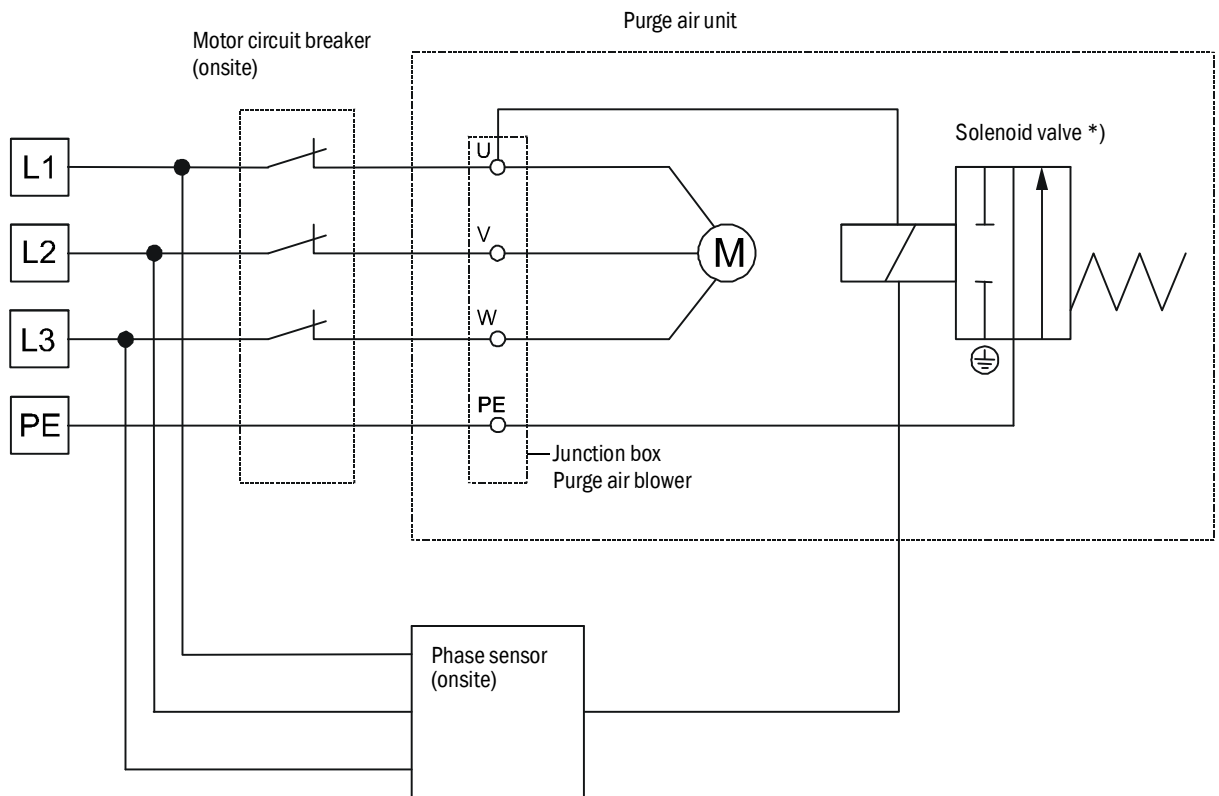

*) In SICK scope of delivery but not fitted

3.3.5 Installing the sender/receiver unit

Check the following points before installation:

- ▶ The sender/receiver units must have at least the same nominal length as the flanges with tube.
- ▶ The inside of the flange tubes must be free of welding beads.
- ▶ The inside of the probe tubes on the sender/receiver units must not come into contact with the flange tubes.
- ▶ The cable connection on the electronics unit for sender/receiver units with digital signal transmission must be at the bottom.



For type FLSE100-PR and under consideration of the fitting specifications as shown in Fig. 30, when necessary, loosen the screw connections between the electronics unit and PR connection, rotate the device to the required position (90°, 180°, 270°) and then screw the parts back together again.

Cooling air supply for sender/receiver units with internal cooling FLSE100-MAC/HAC

- ▶ Check/ensure the cooling air supply is in operation.
- ▶ Connect the cooling air hose DN25 to the cooling air connection on the sender/receiver unit (mount the hose clamp on the free hose end, connect the purge air hose and secure it with the hose clamp).
- ▶ Make sure cooling air is fed from below and discharged from below (see Fig. 69).
- ▶ If this is not guaranteed, loosen the screwed connections between the cooling air connection and the duct probe, rotate the unit accordingly (90°, 180°, 270°), and screw the parts back together again.
- ▶ If the optional cooling air supply in the junction box is used, slide the free end of the cooling air hose on adapter 40-25 and secure it with the hose clamp.

Purge air supply for purged sender/receiver units FLSE100-PM, PH, PH-S

- ▶ To minimize corrosion when using corrosive gases, ensure the nominal lengths of the sender/receiver units are at least one length longer than the nominal lengths of the flanges with tube (→ p. 27, 2.3.1.3).
 - ▶ Check/ensure the purge air supply is in operation.
 - ▶ Connect the purge air hoses, to do this, connect the hose clamp loosely on the free hose end, connect the purge air hose to the purge air connection on the sender/receiver units, and secure it with the hose clamp.
- Check/ensure the purge air is fed from below and the purge air flows out in the direction of the gas flow.

Fig. 69

Alignment of cable connection and purge air supply for purged sender/receiver units (shown for type FLSE100 PM/PH, fitted on a vertical duct)

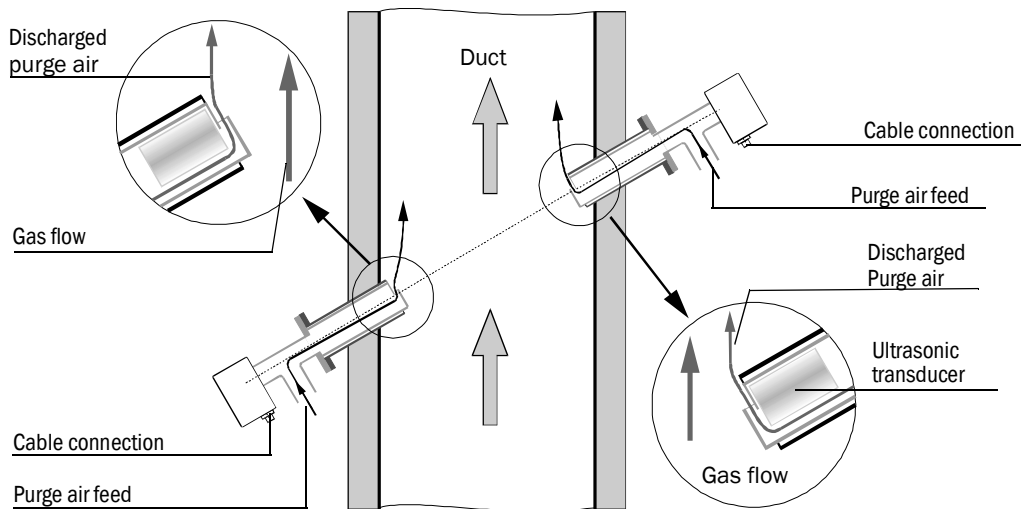

Installation and electrical connection



WARNING:

Only install the sender/receiver units when it is safe to do so (for example, when the system has been shut down, see → p. 9, § 1.3.3).

- ▶ Remove the blind plug from the flange.
- ▶ Insert the sender/receiver units in the flanges with tube as previously described and screw the components together.
- ▶ Connect the cable to the control unit to the plug-in connector on the sender/receiver unit.

3.3.6 Connecting the control unit MCU

Fig. 70 Component layout in the MCU (without cooling air supply, with options)

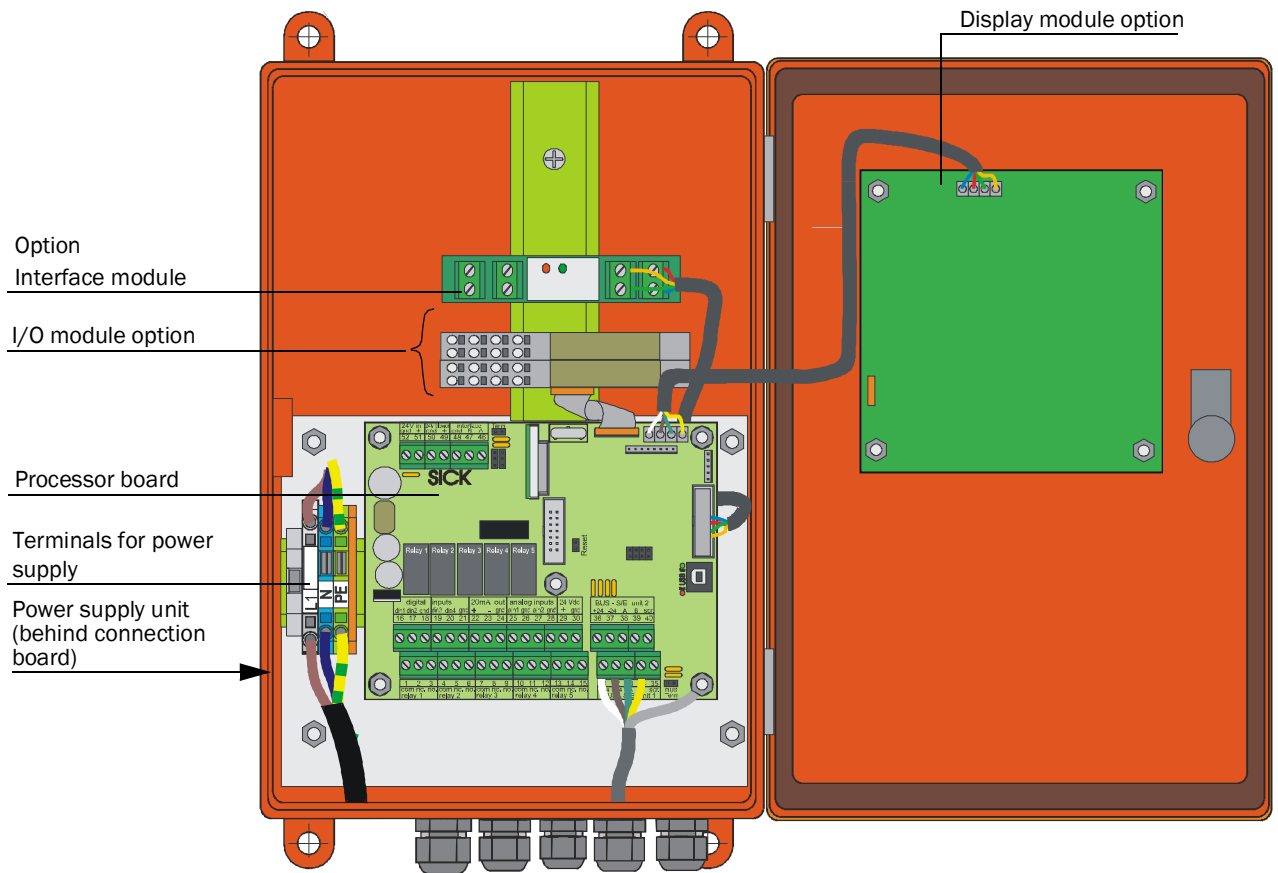

Necessary work

- ▶ Connect the connection cable as shown in Fig. 3.3.8.



We recommend using a bus wiring configuration when the distance between the sender/receiver units and the control unit is large.

- ▶ Connect the cables for status signals (operation/malfunction, limit value, warning, maintenance, check cycle), analog output, analog and digital inputs according to the requirements.
- ▶ Connect power cable to terminals L1, N, PE (→ Fig. 70).
- ▶ Close off unused cable ducts with dummy plugs.

Fig. 71 FLOWSIC100 connection on the MCU (apart from types PR, S)

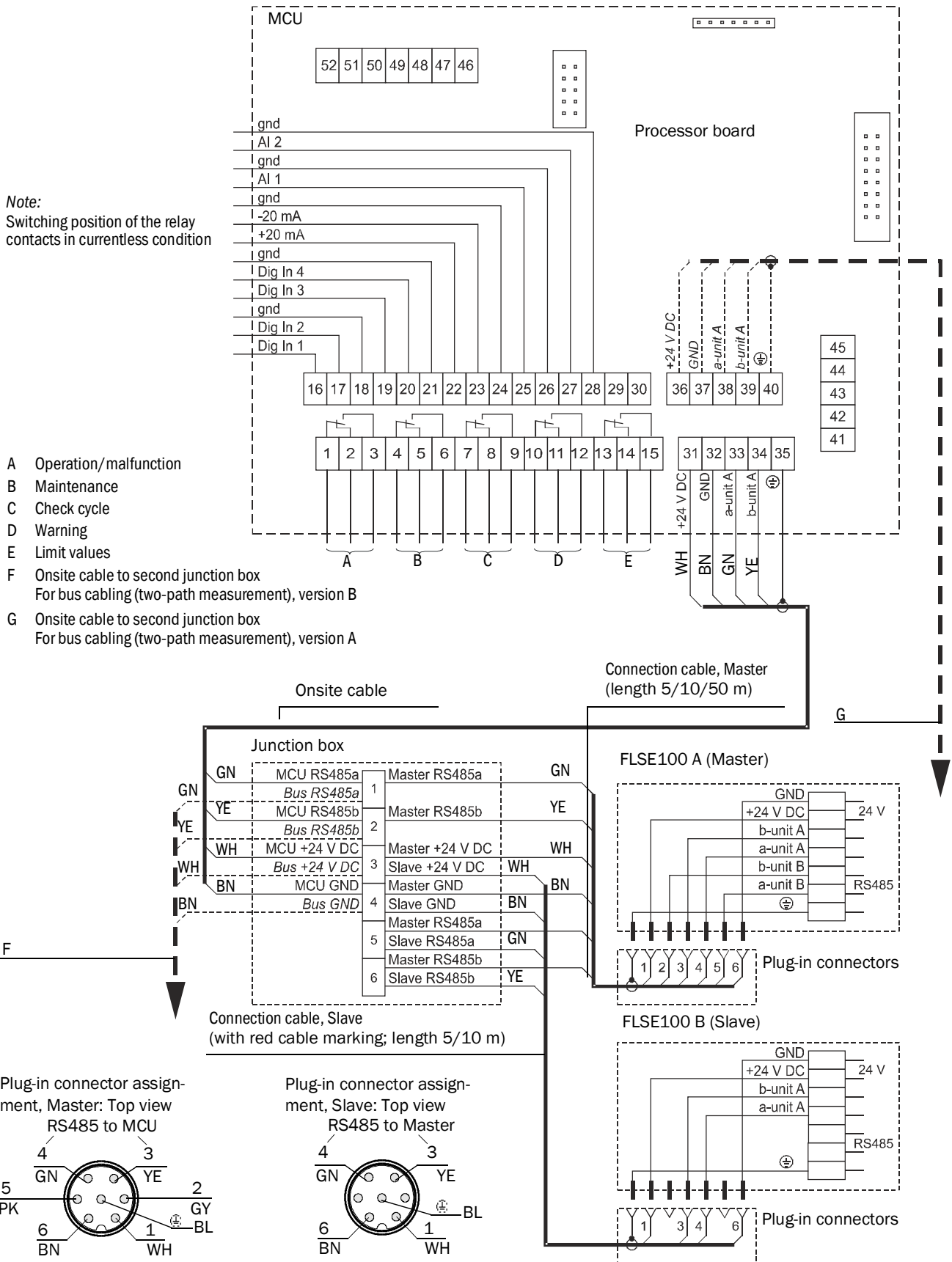

Subject to change without notice

Fig. 72 FLOWSIC100 PR connection on the MCU

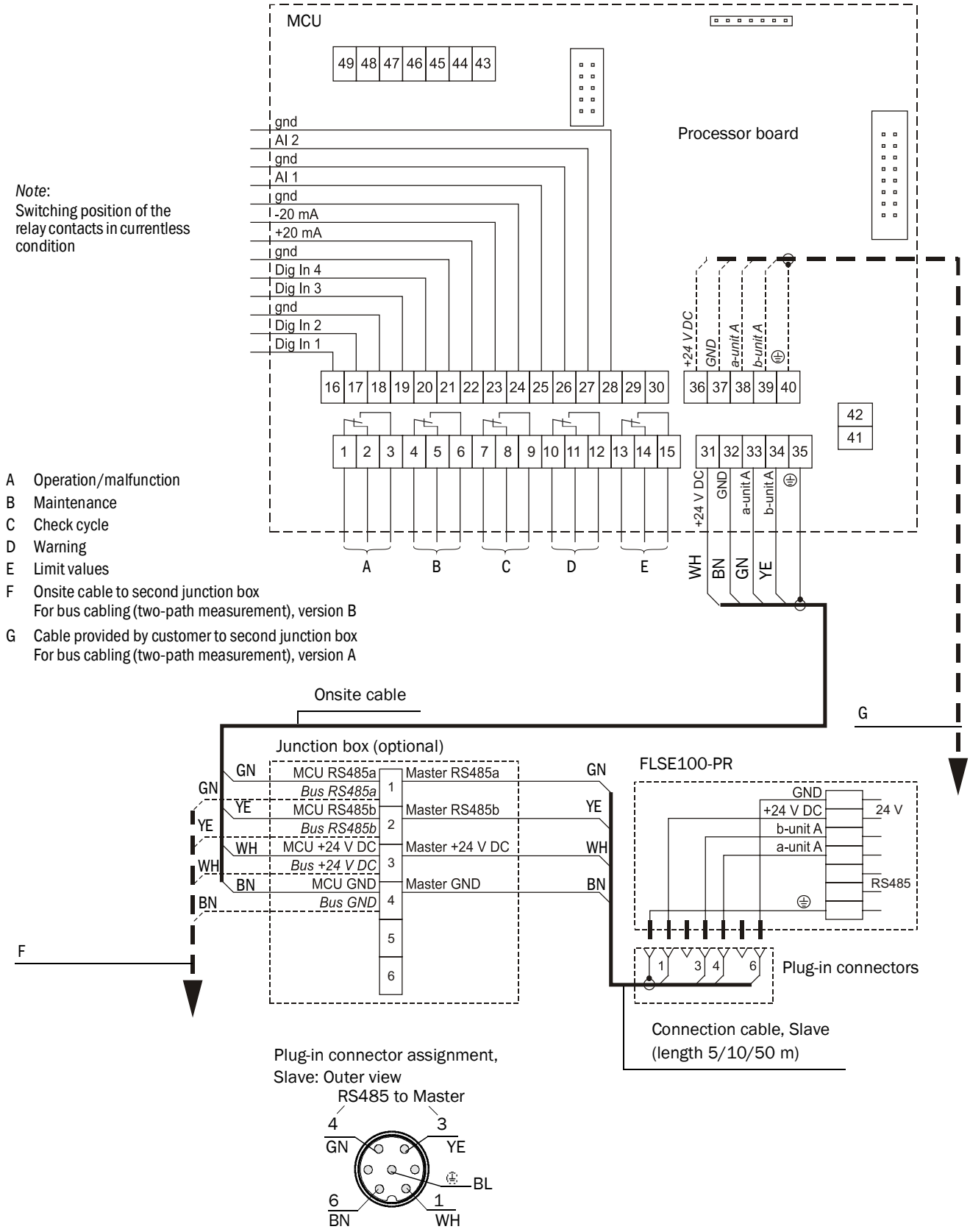

Subject to change without notice

Fig. 73 FLOWSIC100 S connection on the MCU

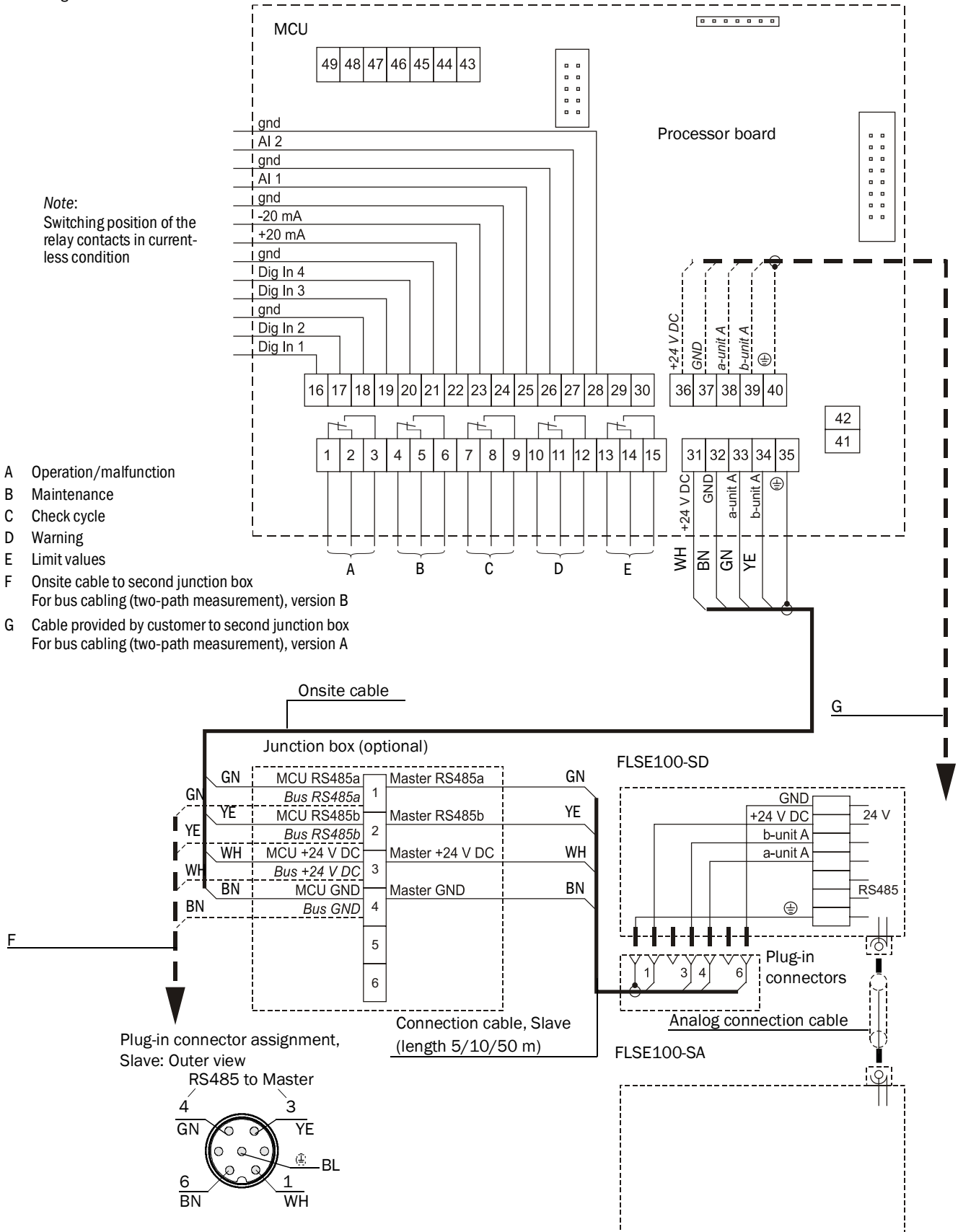

Subject to change without notice



- The connection cable between the control unit and junction box or terminal box must be provided and laid onsite. When choosing the cable type, make sure the lead/lead operational capacity is less than 110 pF/m and the minimum lead cross-section is 0.5 mm² (AWG20).
We recommend using cable type UNITRONIC Li2YCYv(TP) 2x2x0.5 mm² with reinforced outer sheath (from Lappkabel).
- When connecting bus versions with several sensors (→ p. 14, Fig. 3), the maximum cable length is reduced as follows depending on the number of sampling points connected:
 - Cable length with 1 sampling point = 1000 m
 - Cable length with 2 sampling points = 500 mTo implement longer cable lengths:
 - Use larger lead diameter e.g. cable type with 4 lead pairs and 2 lead pairs for power supply
 - Use an MCU with more powerful power supply unitBoth solutions are available from the manufacturer on request.
- For bus wiring, the set termination set at the factory must be deactivated in those system components not at the line end (see Service Manual Section 3.1).

3.3.7 Connecting the control unit in a 19" housing

Fig. 74 Connections on the MCU as 19" version

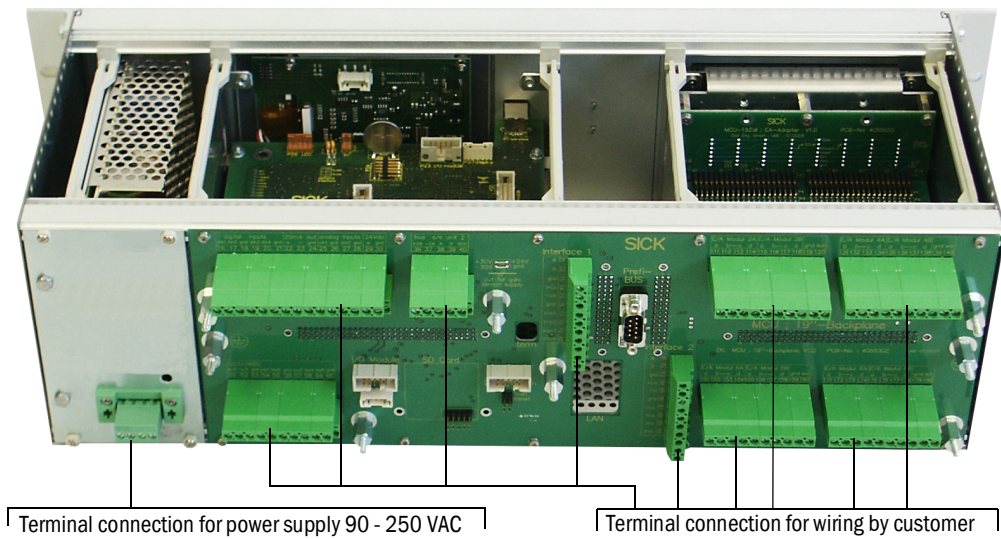

Function	Connection	Terminal No.
Output relay 1 (operation/malfunction)	com	1
	n.c. ¹⁾	2
	n.o. ²⁾	3
Output relay 2 (maintenance)	com	4
	n.c. ¹⁾	5
	n.o. ²⁾	6
Output relay 3 (check cycle)	com	7
	n.c. ¹⁾	8
	n.o. ²⁾	9
Output relay 4 (maintenance request)	com	10
	n.c. ¹⁾	11
	n.o. ²⁾	12
Output relay 5 (limit value)	com	13
	n.c. ¹⁾	14
	n.o. ²⁾	15
Digital input	d in 1	16
	d in 2	17
	gnd	18
	d in 3	19
	d in 4	20
	gnd	21
Analog output	+	22
	-	23
	gnd	24
Analog input	a in 1	25
	gnd	26
	a in 2	27
	gnd	28

Subject to change without notice

Function	Connection	Terminal No.
Master sender/receiver unit (unit 1) connections	+24	31
	-24	32
	RS485 A	33
	RS485 B	34
	scr.	35
Master sender/receiver unit (unit 2) connections	+24	36
	-24	37
	A	38
	B	39
	scr.	40
Input voltage supply 24V DC ³⁾	24 V	41
	gnd	42
Output voltage supply 24 V DC ³⁾	24 V	43
	gnd	44
Input 30 V electr. isolated	+	45
	-	46
RS232/485 ³⁾	tx/A	51
	rx/B	52
	gnd	53
Interface 1	A	71
	B	72
	gnd	73
	+Us	74
	-Us	75
	gnd	76
	imp+	77
	imp-	78
	res 1	79
	res 2	80

1): Closed in current-free state (normal closed)

2): Open in current-free state (normal opened)

3): Only use after agreement with manufacturer

Fitting and connecting optional I/O modules

Connect the optional analog and digital modules to the slots on the module carrier as from slot 1 next to each other in the sequence AO → AI → DO → DI. If single module types are not present, the next one follows according to the specified sequence.

Fig. 75

Slots for optional modules

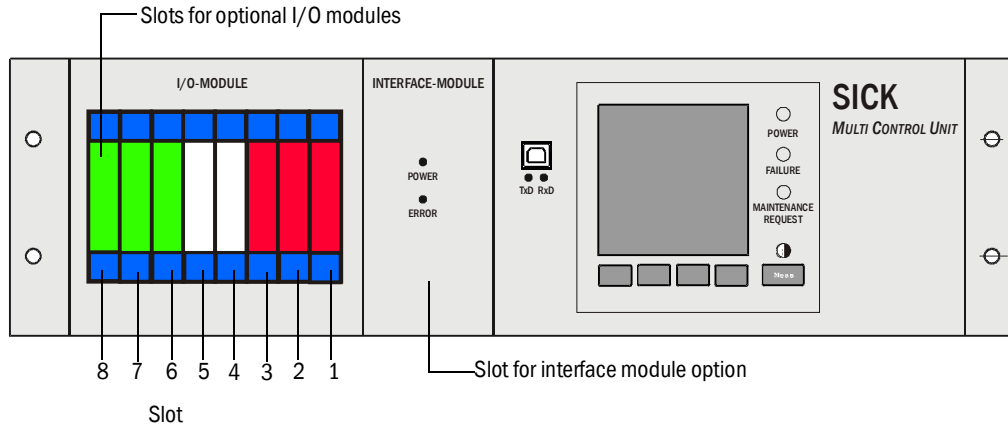

Connection is made to terminals 101 - 180 on the backplane.

The following shows the I/O module connection for slot 1 as an example.

Connect the I/O modules to slots 2 -8 in the same manner.

- Analog module connection

Fig. 76

Analog module on slot 1 (terminals 101 - 110)

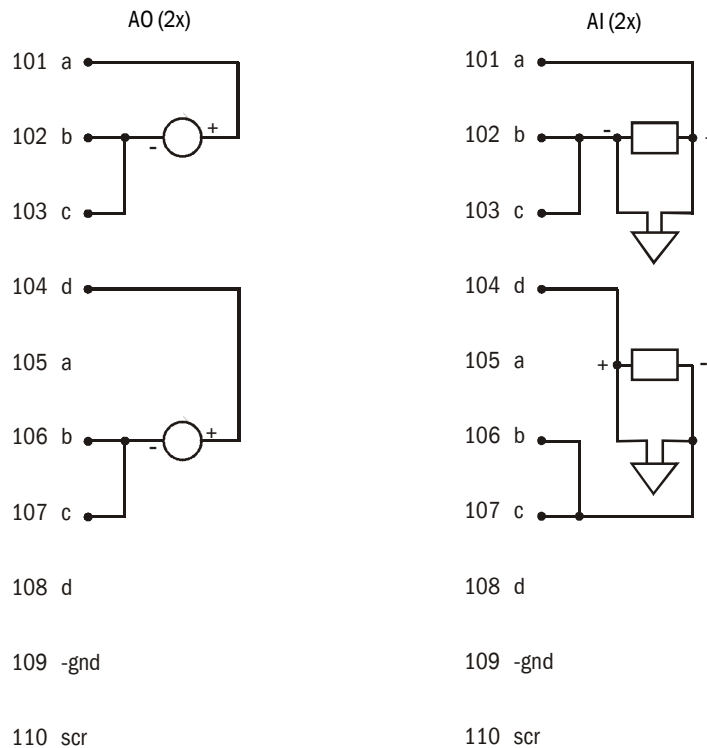

- Connection digital module (not available at present)

Fig. 77 Connection digital module on slot 1

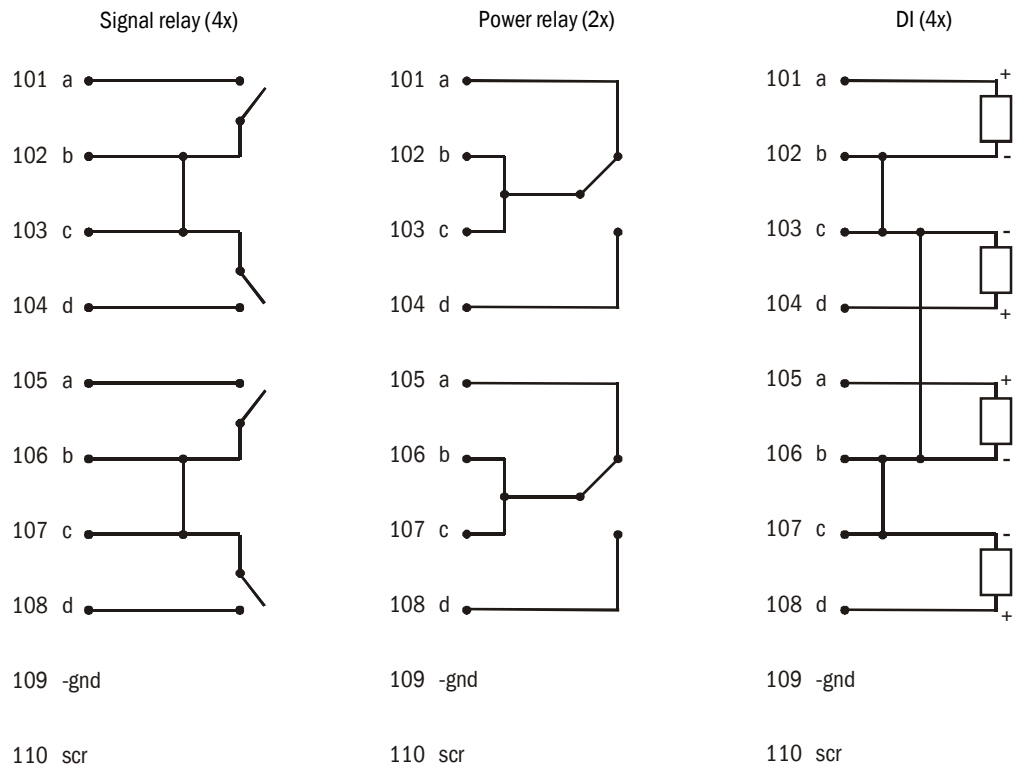

3.3.8 Terminating the sender/receiver units when operating the FLOW SIC100 with "2-path measuring" configuration

3.3.8.1 Checking the sender/receiver unit(s) - MCU connection

Checking the termination

The connection between sender/receiver units and MCU must be terminated at the start and end with resistors for both single and bus wiring. The terminating resistors are already on the circuit boards and are activated by fitting jumpers on the respective pins.

Fig. 78 Termination of bus wiring

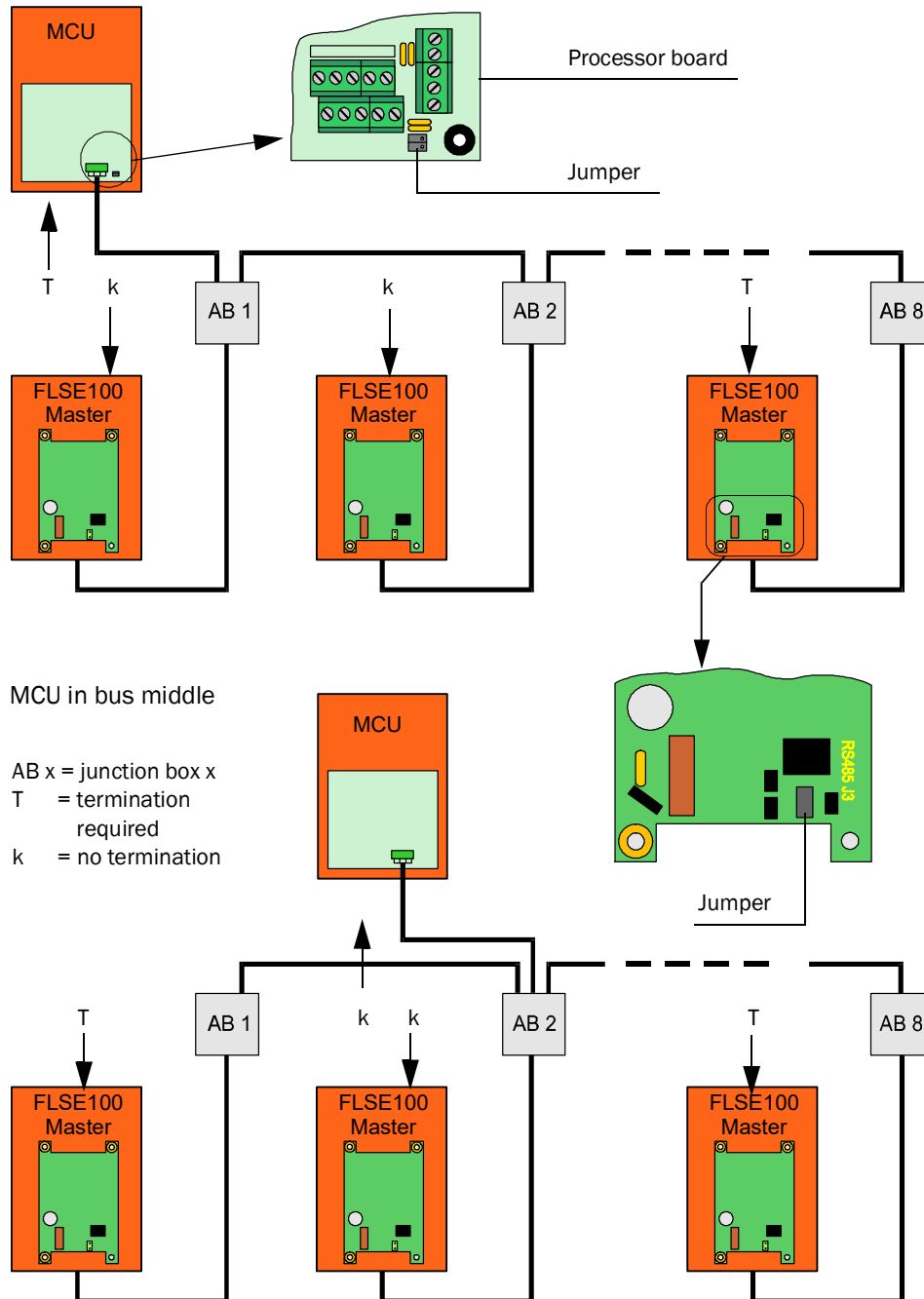



Subject to change without notice

3.3.8.2 **Bus addressing**

On bus systems (several sender/receiver units on one MCU), the required bus address of a sender/receiver unit (master only) can be assigned by the hardware or software. Hardware addressing is read in when SOPAS ET starts and has a higher priority than software addressing. Software addressing is only available for SICK Service (SOPAS password level "SICK Service").

Bus addresses and sensor numbers in the MCU (see Section 4) are always identical.

NOTICE:
 After a possibly necessary change of addressing, the respective sender/receiver units must be started anew (disconnect and reconnect supply voltage). The output assignments in the MCU then have to be reconfigured (see Section 4).

WARNING:
 The sender/receiver units must have different addresses. Identical addresses for several units cause the communication with the MCU to abort!

3.3.8.3 **Hardware addressing**

As standard, the address is set using a miniature switch on the digital board in the sender/receiver unit (3 switches for hexadecimal addressing from address 1 to 7, see Fig. 3.2). The address assigned to a sender/receiver unit upon delivery is noted in the electronics housing.

Fig. 79 Hardware addressing of sender/receiver unit

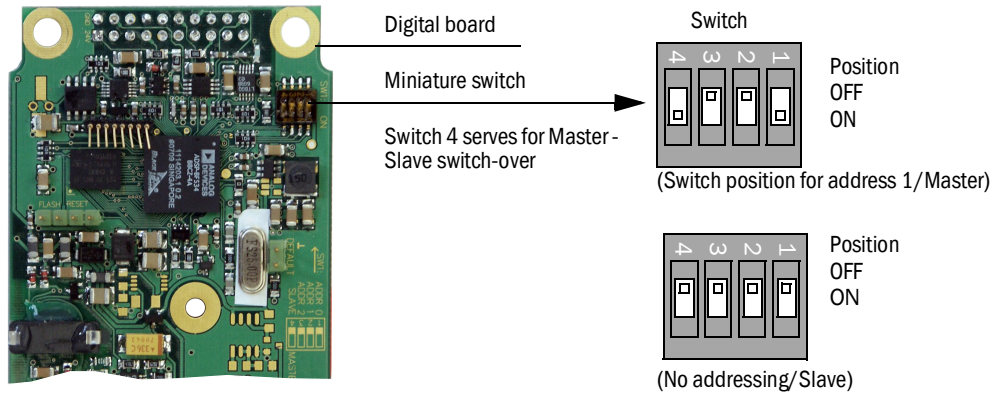

Address	0			1			2			3			4			5			6			7		
Switch	1	2	3	1	2	3	1	2	3	1	2	3	1	2	3	1	2	3	1	2	3	1	2	3
ON				x				x		x	x					x	x			x	x	x	x	x

NOTICE:
 Only address 1 or for two-path operation, addresses 1 and 2, may be selected for the FLOWSIC100.

Subject to change without notice

3.3.9 Installing and connecting the interface and I/O module options

Plug these modules onto the top hat rail in the MCU (→ p. 97, Fig. 70) and connect to the associated connection on the processor board with the cable with plug-in connector (→ p. 36, Fig. 22).

MCU in wall housing

- Terminal assignment of AO module

Fig. 80 Terminal assignment of analog output module

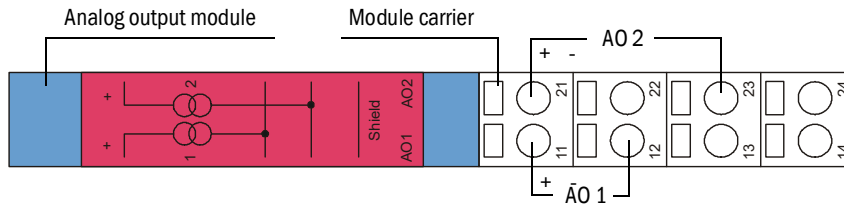

- Terminal assignment of AI module

Fig. 81 Analog input module terminal assignment

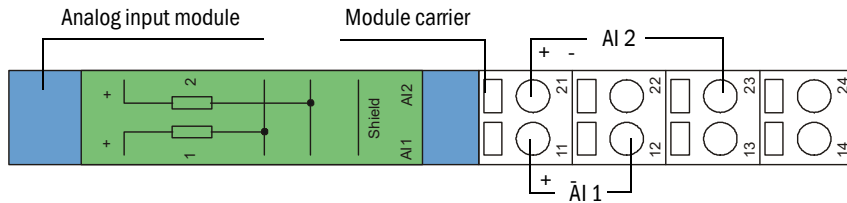

WARNING: The analog input module will be damaged if incorrectly connected.

- ▶ Do not connect the terminals 12, 22, 13, 23 of the analog input module to GND or earth if the terminals 11, 12 are connected to the internal supply of the MCU (delivered configuration) or with another external supply.

- Terminal assignment DO module (2 changeover contacts)

Fig. 82 Digital output module terminal assignment

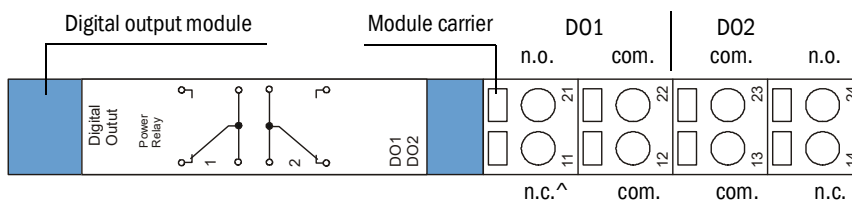

NOTICE: Screw terminals for wire sizes 0.5 .. 1.5 mm² (AWG20 ... AWG16).

● Terminal assignment DO module (4 NO contacts)

Fig. 83

Terminal assignment digital output module (4 NO contacts)

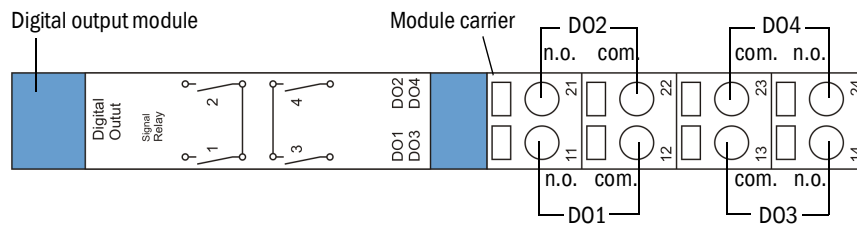

● Terminal data

Connection	Module type				
	2x analog input input	2x analog input output	2x digital input input	Digital output	Digital output
				2 changeover contacts	4 NO contacts
Assignment					
11	AI 1+	AO 1+	DI 1+	n.c. relay 1	n.o. relay 1
12	AI 1-	AO 1-	gnd	com. relay 1	com. relay 1
13	AI 2-	AO 2-	gnd	com. relay 2	com. relay 3
14	Screen (gnd)	Screen (gnd)	DI 3+	n.c. relay 2	n.o. relay 3
21	AI 2+	AO 2+	DI 2+	n.o. relay 1	n.o. relay 2
22	AI 1-	AO 1-	gnd	com. relay 1	com. relay 2
23	AI 2-	AO 2-	gnd	com. relay 2	com. relay 4
24	Screen (gnd)	Screen (gnd)	DI 4+	n.o. relay 2	n.o. relay 4
Load					
max. voltage	3 V d.c.	15 V d.c.	5.5 V d.c.	30 V a.c./d.c.	24 V DV
max. current	22 mA	22 mA	5 mA	2 A	36 mA

n.c.: normal closed

n.o. normal open

● Terminal assignment interface modules

Fig. 84

Interface module terminal assignment

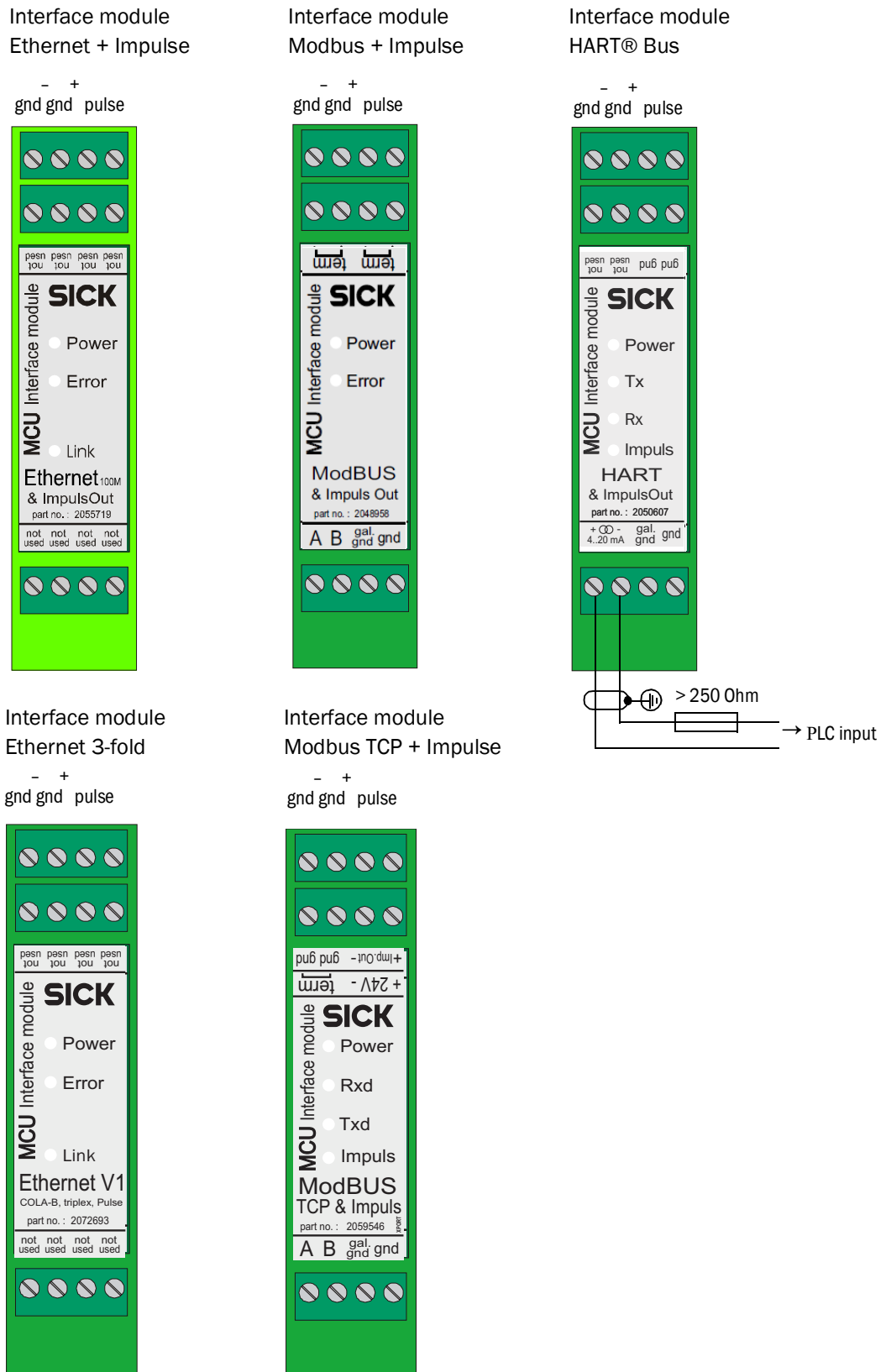

Subject to change without notice

Fig. 85

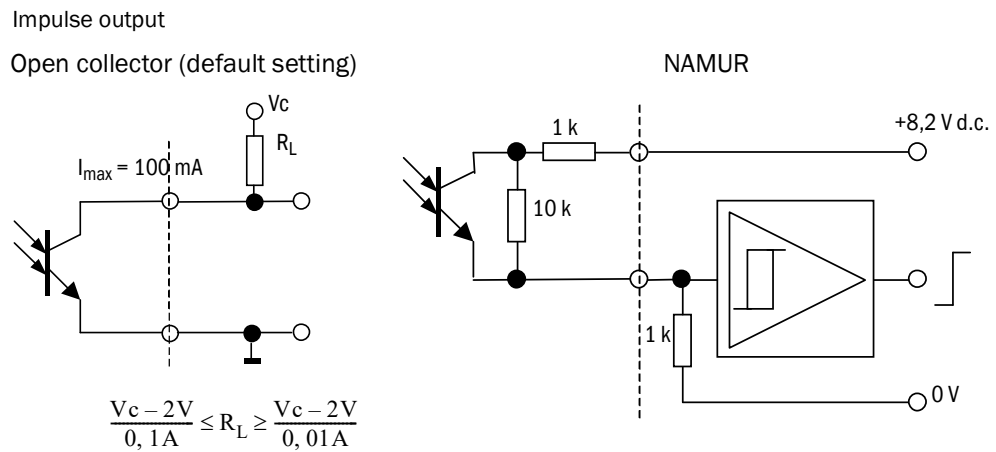

NOTICE:

I_{max} (Open collector connection) may not exceed 100 mA. Otherwise the impulse output can be destroyed.

Calculate R_L according to the equation above.

FLWSIC100

4 Start-up and parameter settings

Basics

Standard start-up procedure

Advanced start-up

Operating / Configuring with the LC-Display option

4.1 Basics

4.1.1 General information

Start-up primarily comprises entering system data (e.g. measuring path, installation angle), parameter settings for output variables and reaction times and, if required, the check cycle setting (→ p. 126, 4.2). A zero adjust is not required.

Additional calibration of the velocity measurement by means of a network point measurement using a reference system (for example, dynamic pressure probe) is only necessary when the velocity profile along the measuring axis is not representative for the entire cross-section (→ p. 51, 3.1.1). The regression coefficients determined can then be entered into the device without problems (→ p. 144, 4.3).

If the gas temperature determined with the FLOWSIC100 is to be used to scale the volume flow, a calibration with external temperature sensor is necessary in such cases (→ p. 144, 4.3). This is because the sound velocity of the real gas under standard conditions is seldom known.

The operating and configuration software “SOPAS Engineering Tool” (SOPAS ET) is supplied with the device for configuring the system parameters. The required settings can be easily configured using the software menus. Further functions are also available (e.g., data storage, graphic displays).

If the standard settings do not provide adequate stability under all plant conditions (for example, if the device is not used according to the specifications set out in the Technical Data), system performance can be enhanced by optimizing the internal parameter settings. These settings, however, must only be configured by adequately qualified personnel, since correct device operation cannot be guaranteed if the settings are defined incorrectly. Changes of this kind should be carried out by SICK Service personnel only. Possible settings are listed in the Service Manual.

4.1.2 Installing SOPAS ET

Prerequisites for configuring using SOPAS ET

- Laptop/PC with:
 - Processor: at least Pentium III 500 MHz (or comparable type)
 - USB interface (alternative - RS232 via adapter)
 - Working memory (RAM): At least 1 MB
 - Operating system: MS-Windows XP, VISTA, Windows 7 and Windows 8 (32/64 bit)
 - Free memory: 450 MB
- USB interface cable to connect the laptop/PC to the FLOWSIC100 (MCU).
- The SOPAS ET software as well as the USB driver (scope of delivery) must be installed on the laptop/PC.
- The voltage supply must be switched on.

Installing SOPAS ET

- ▶ Insert the enclosed CD into the disk drive on the PC, select the language, choose “Software” and follow the instructions.

Installing the USB driver

A special hardware driver is required for communication between SOPAS ET and the FLOWSIC100 visibility measuring system via USB interface. This must be installed on the laptop/PC:

- ▶ Connect the USB interface cable to the PC.
A message appears on the screen that new hardware has been found.
- ▶ Insert the delivered CD in the PC drive and follow the installation instructions.

Fig. 86

Installing the USB driver

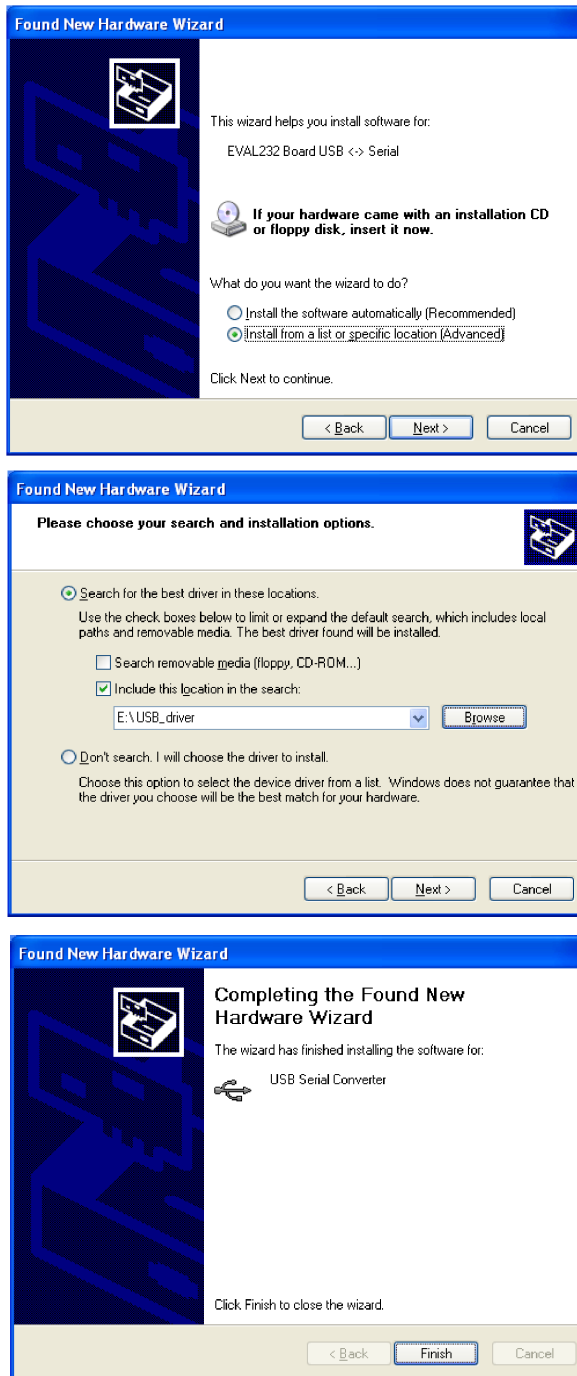

Subject to change without notice

4.1.3 Connecting the device

- ▶ Connect the USB cable to the MCU(P) control unit (→ p. 30, Fig. 18) and the laptop/PC.



NOTICE:

The MCU(P) is connected via USB to the laptop/PC.
A serial interface (COM port) is simulated via which the connection is made.

- ▶ Start the software from the “SICK\SOPAS” start menu.
- ▶ The start page is displayed.

4.1.3.1

Changing the language

- ▶ If required, set the desired language in the “Tools / Language” menu (→ p. 116, Fig. 87).
- ▶ Confirm the dialog shown with “Yes” to restart SOPAS ET with the changed language.

Fig. 87 Changing the language setting

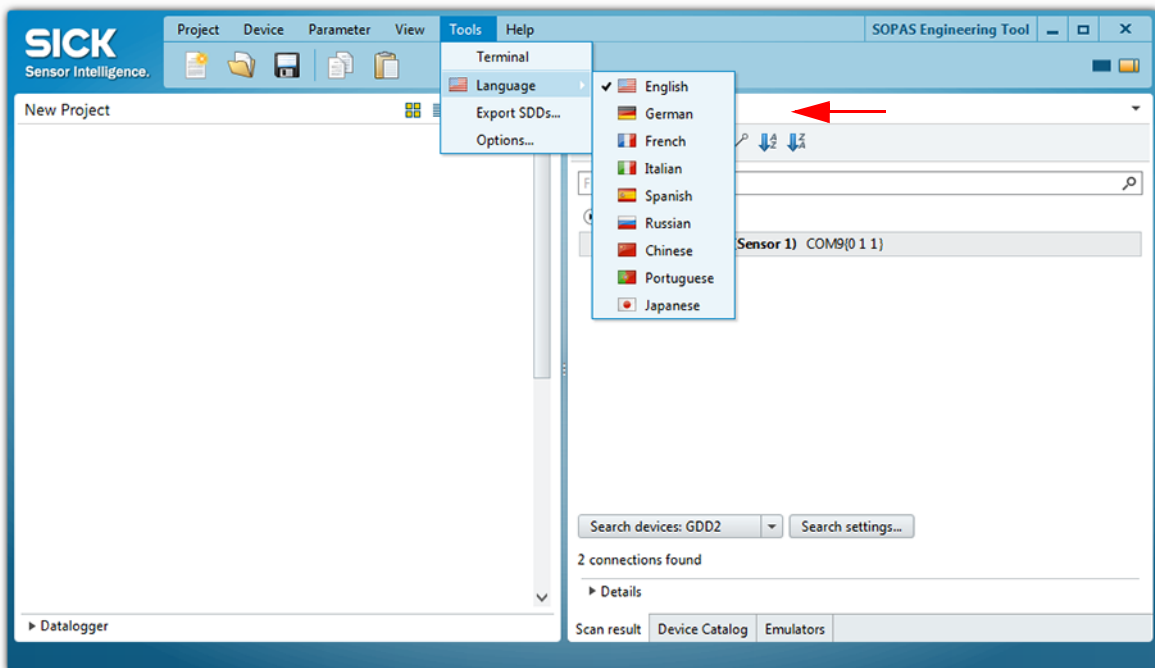

4.1.3.2 **Connecting to the device via the “Device family” mode (recommended search settings)**

- 1 Click “Search settings”.
- 2 Select search mode “Device family oriented search” and click “Next”.

Fig. 88 Selecting the search mode

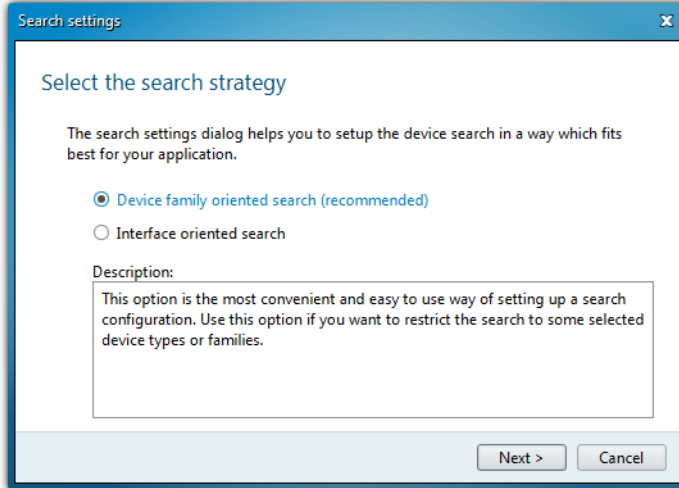

- 3 Select device family “MCU” and click “Next”.

Fig. 89 Selecting the device family

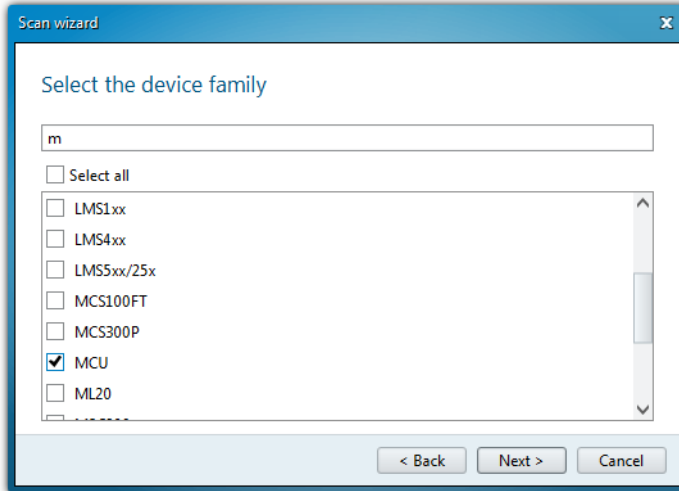

- 4 If devices are to be connected via Ethernet, configure the IP addresses:

 **NOTICE:**
MCU(P) does not support automatic recognition of IP addresses (SICK AutoIP), the IP addresses therefore have to be configured manually.

- ▶ Click “Add”.

 An IP address specified by the customer is entered at the factory when the address is available when the device is ordered. If not, standard address 192.168.0.10 is entered.
To change the IP address, see → p. 151, § 4.3.6.

Subject to change without notice

- ▶ Enter the IP address of the device or the IP address range when several devices are used (→ p. 118, Fig. 90). The IP addresses shown are exemplary.
- ▶ Click “OK”.

Fig. 90 Connection settings for connection via Ethernet (example)

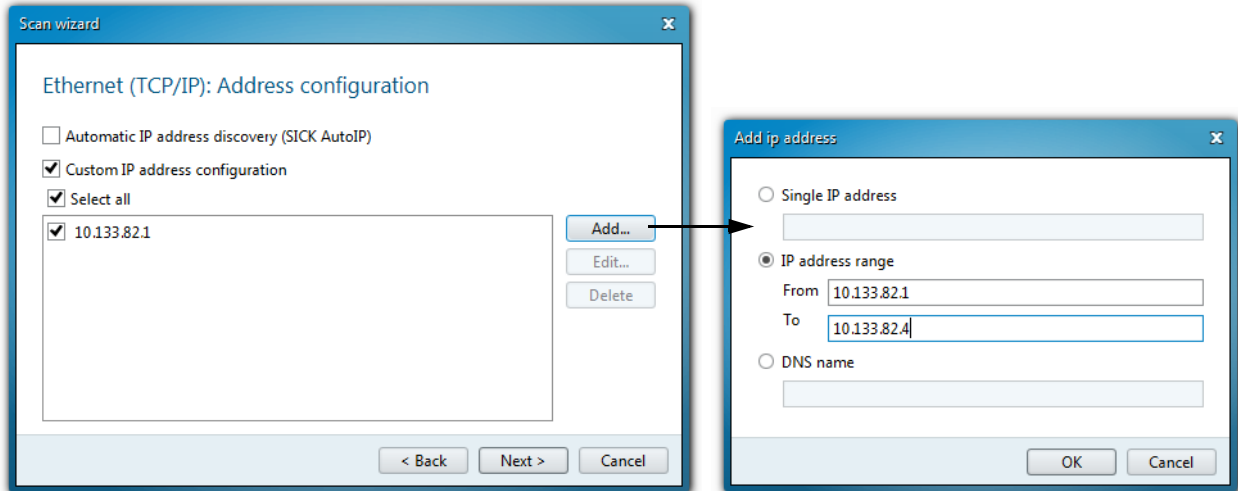

- 5 Click “Next”.
- 6 When devices are connected via serial connections (COM ports), select the COM ports used and click “Next”.



NOTICE:

The MCU(P) is connected via USB to the laptop/PC.
A serial interface (COM port) is simulated via which the connection is made.

- ▶ If you are not sure which COM ports are used, select all COM ports.

Fig. 91 Selecting COM ports

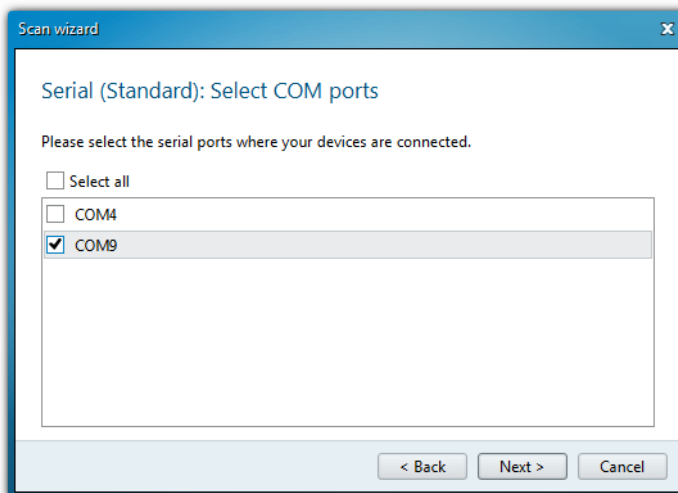

- 7 To save the search settings, enter a name and click “Finish”.
SOPAS ET starts the device search.
The devices found are displayed in the “Device search” area when device search is finished (→ p. 122, Fig. 98).

Fig. 92 Saving the scan configuration

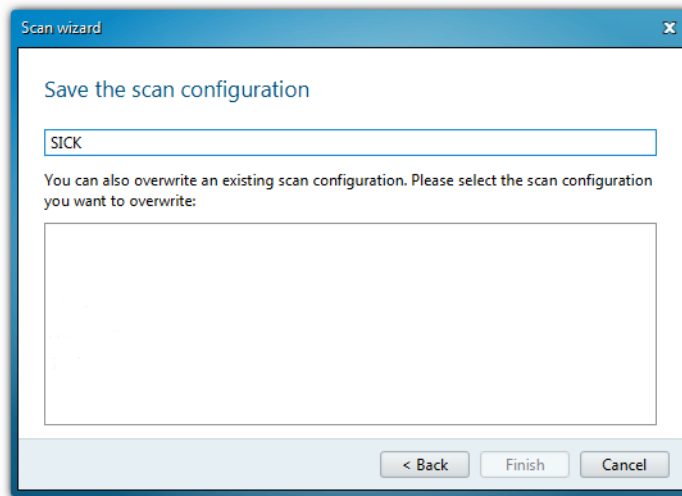

4.1.3.3 Connecting to the device with advanced mode

- 1 Click "Search settings".
- 2 Select search mode "Interface oriented search".
- 3 Select the communication interfaces where the search is to be made and click "Next".

Fig. 93 Selecting the communication components

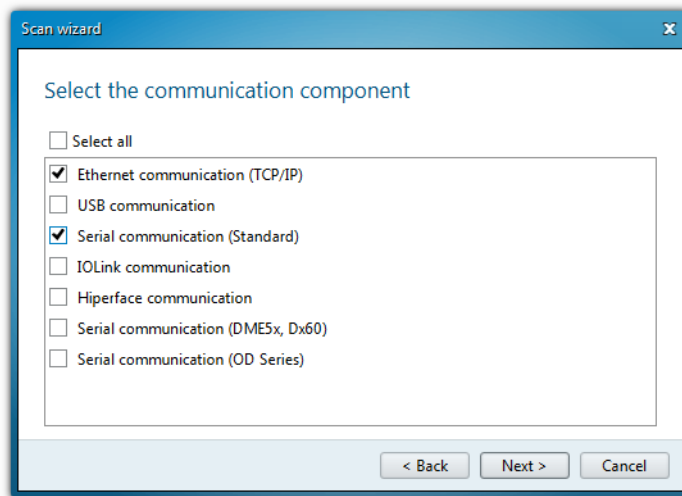

- 4 Configure the interfaces and click "Next".

Ethernet communication

- ▶ Select “Custom IP address configuration”.
- ▶ Click “Add”.
- ▶ Enter the IP address of the device or the IP address range when several devices are used and confirm with “OK”.
- ▶ Select TCP port 2111 in the “TCP port” directory.
- ▶ Define the protocol settings in the “Protocol” directory according to → p. 120, Fig. 94.

Fig. 94

Defining the protocol settings

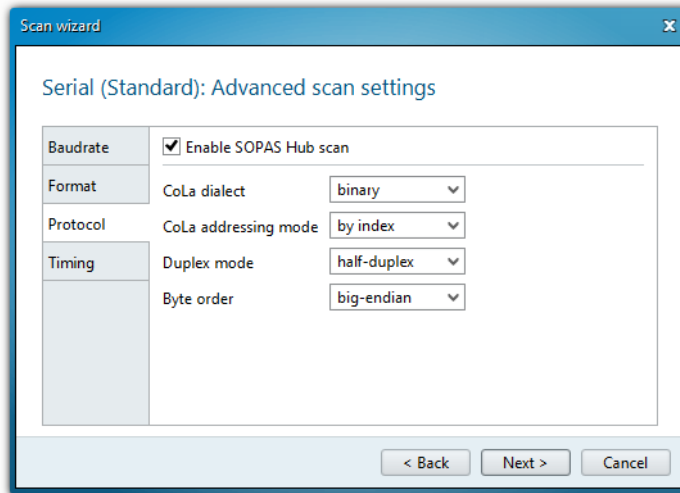

- ▶ Define the timeout settings in the “Timing” directory according to → Fig. 95.

Fig. 95

Defining the timeout settings

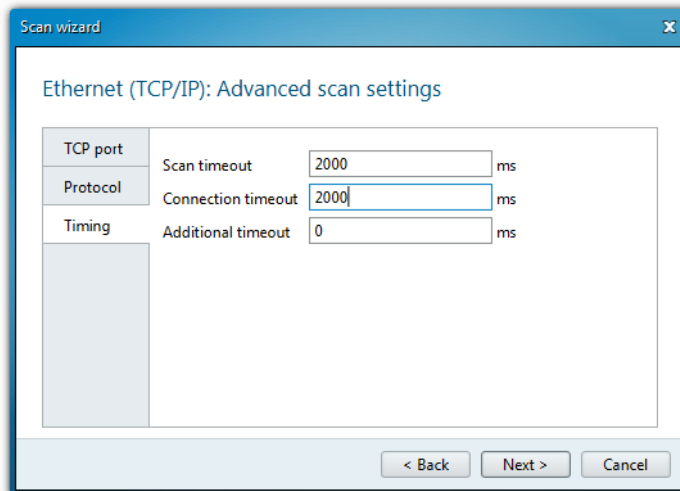

Serial communication (when connected via USB)



NOTICE:

The MCU(P) is connected via USB to the laptop/PC.
A serial interface (COM port) is simulated via which the connection is made.

- ▶ Select the COM ports used.
- ▶ If you are not sure which COM ports are used, select all COM ports.
- ▶ Define the baudrate settings in the “Baudrate” directory according to → p. 121, Fig. 96.

Fig. 96

Defining the baudrate

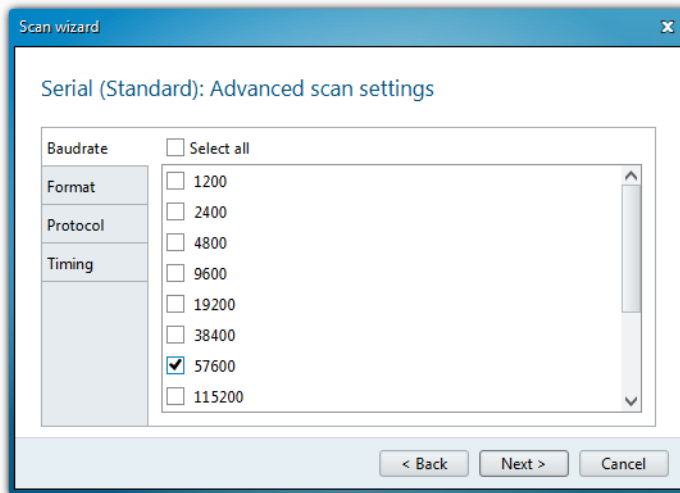

- ▶ Configure the data format in the “Format” directory according to → p. 121, Fig. 97.

Fig. 97

Configuring the data format

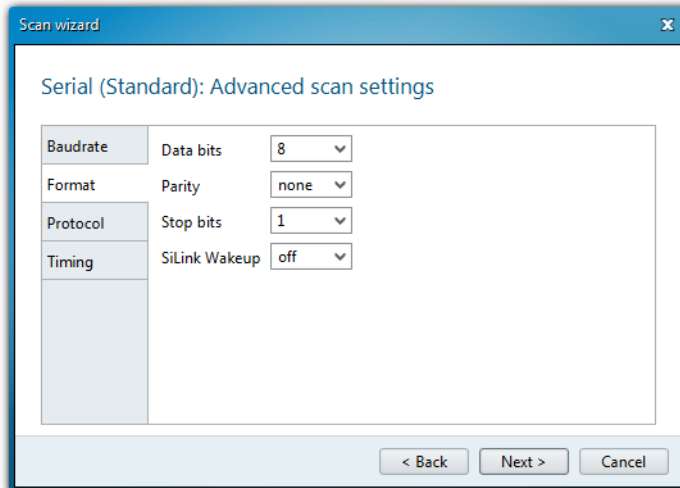

- ▶ Define the protocol settings in the “Protocol” directory according to → p. 119, Fig. 93.
 - ▶ Define the timeout settings in the “Timing” directory according to → p. 120, Fig. 94.
- 5 To save the scan settings, enter a name and click “Finish” (→ p. 119, Fig. 92).
SOPAS ET starts the device search. The devices found are displayed in the “Device search” area when device search is finished (→ p. 122, Fig. 98).

Subject to change without notice

4.1.4 Information on using SOPAS ET

Fig. 98 Overview

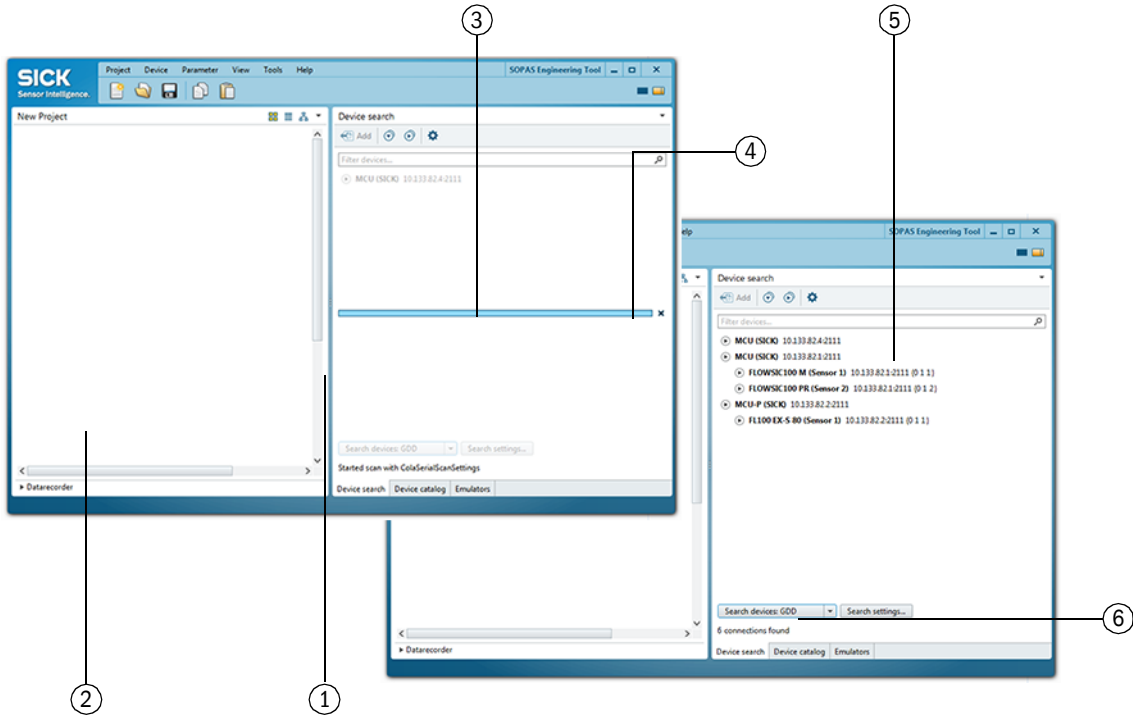

- 1 Device search
- 2 Project area
- 3 Device search progress
- 4 Device search abort
- 5 Device search result
- 6 Number of devices found

Device selection

- ▶ Move the required devices with drag-and-drop or a double-click on the required device into the project area.
 - The configuration of the devices is shown in a separate device window.
 - The device windows can be opened by a double-click on the respective device file or the context menu (→ p. 124, Fig. 100).

Fig. 99 Device selection

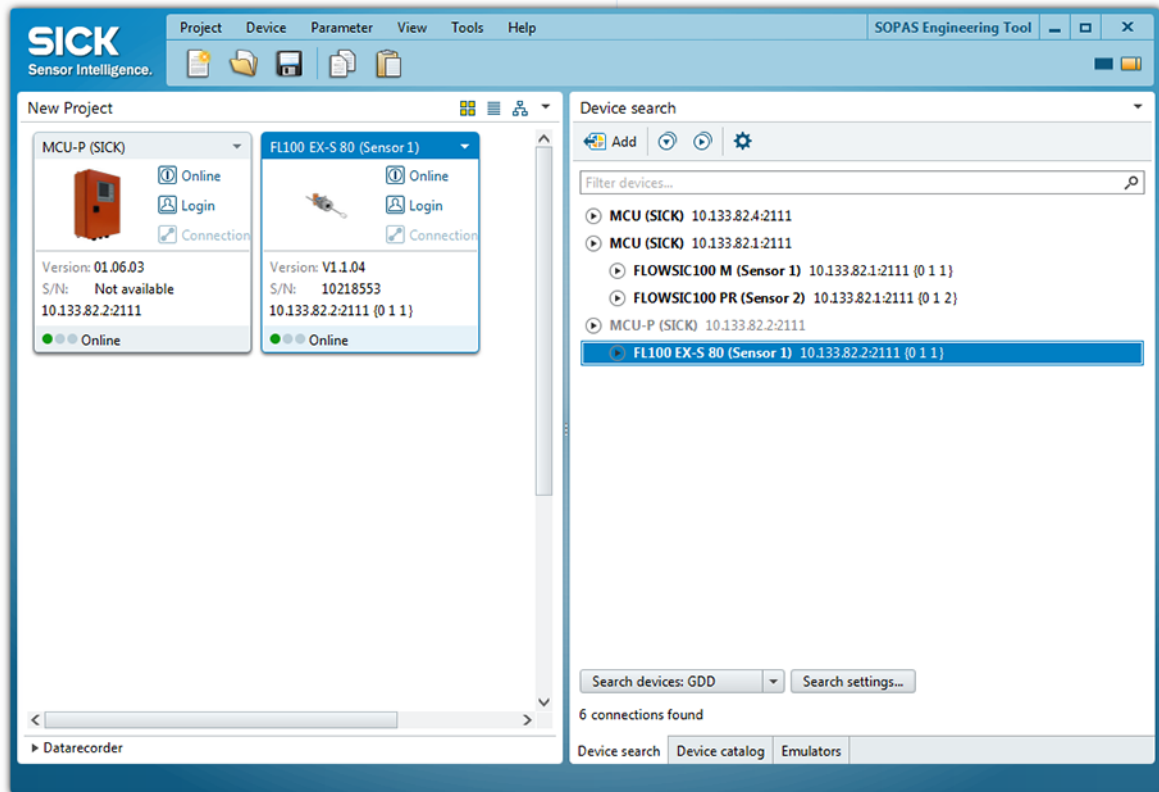

Fig. 100

Device context menu

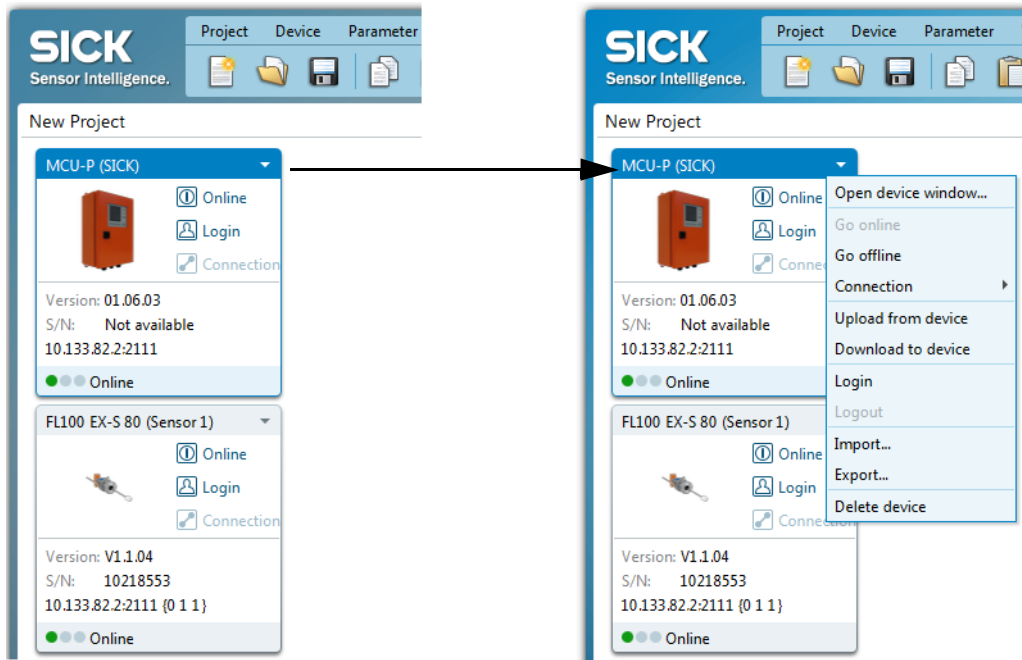

Table 3

Contents of device context menu

Context menu	Description
Go online	Establishes the connection between SOPAS ET and the device.
Go offline	Interrupts the connection between SOPAS ET and the device.
Connection	<ul style="list-style-type: none"> - Select Connection: Changes the connection settings. - Deselect Connection: Deletes the connection settings.
Upload from device	Uploads all parameter values from the connected device and transfers them to SOPAS ET.
Download to device	Downloads the parameter values from SOPAS ET to the connected device. Only those parameter values which can be written at the currently logged in user level are downloaded.
Login	Opens the login dialog.
Logout	Logs out the user from the device.
Import	Imports a suitable device from the *.sopas file and overwrites the parameter values with the values saved in the *.sopas file. During import to an online device, the parameters are immediately downloaded to the device. Only those parameter values which can be written at the currently logged in user level are downloaded.
Export	Exports the device information and the associated project information and saves them in a *.sopas file.
Delete device	Deletes the device from the project.

Password

Certain device functions are first accessible after a password has been entered (→ Fig. 101). Access rights are assigned in 3 user levels:

User level		Access to
0	“Operator” (machine supervisor) *	Displays of measured values and system status
1	“Authorized Operator” (Authorized Client) *	Displays, inquiries and parameters required for start-up or adjustment to customer-specific demands and diagnosis
2	“Service”	Displays, inquiries as well as the main parameters required for service tasks (e.g. diagnosis and clearance of possible malfunctions)

*) : Depending on program version

The Level 1 password is “sickoptic”.

Fig. 101 Entering the password

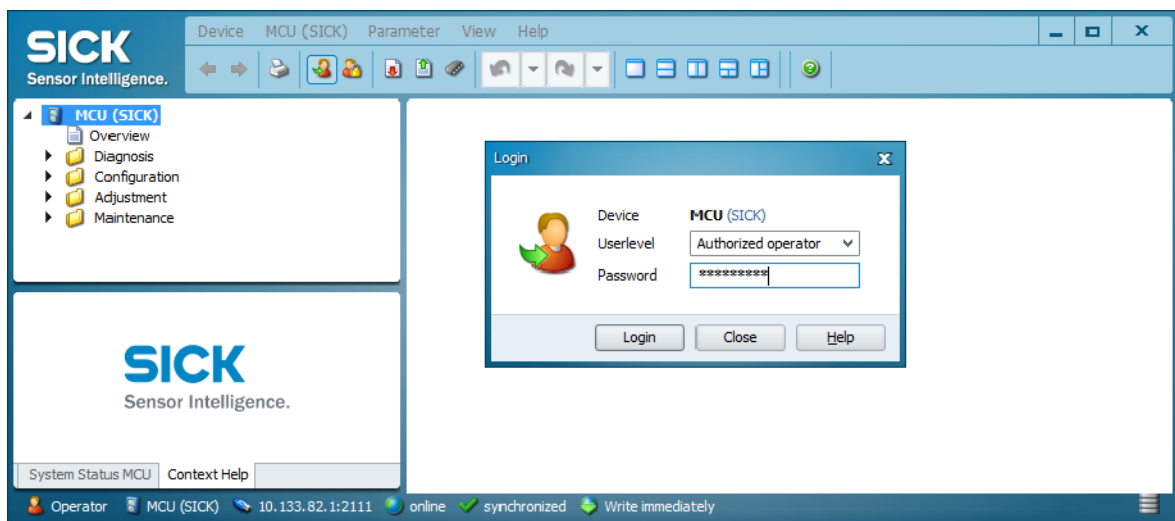

4.2

Standard start-up procedure

This Section describes all the settings essential to ensure the device functions correctly. These include entering system data (active measuring path, installation angle, cross-sectional area) and creating the check cycle, analog output, analog inputs (to read in external signals) as well as the damping time.

**NOTICE:**

- Error message “Error Parameter” is output as long as the system data have not been entered completely on the system component “FLAWSIC100 X (Sensor)”.
- Parameter settings can only be made when the relevant system component “FLAWSIC X (Sensor)” or control unit “MCU” is in the “Maintenance” operating state.

Configuring the device runs using SOPAS ET on the system components “FLAWSIC X (Sensor)” and control unit “MCU” as follows:

Setting	FLAWSIC X (Sensor)	MCU
Measuring path	X	
S/R unit(s) installation angle	X	
Cross-sectional area	X	
Reaction time		X
Check cycle		X
Standard analog output		X



Calibration settings → p. 144, 4.3

To set/change the parameters, carry out the following procedure:

- ▶ Connect the measuring system to program SOPAS ET, scan the network and add the required device file („MCU”, „FLAWSIC100 X (sensor)”) to the current project.
- ▶ Enter the Level 1 password (→ p. 125, Fig. 101) and set the relevant system components to “Maintenance” operating mode (→ p. 127, §4.2.1).

4.2.1 Setting “Maintenance” mode

- ▶ Open the directory “Maintenance/Maintenance Status”.
- ▶ Activate the checkbox “Maintenance” (MCU) or “Sensor maintenance” (sender/receiver unit) and click “Set Status”.

Fig. 102 Switching to Maintenance mode

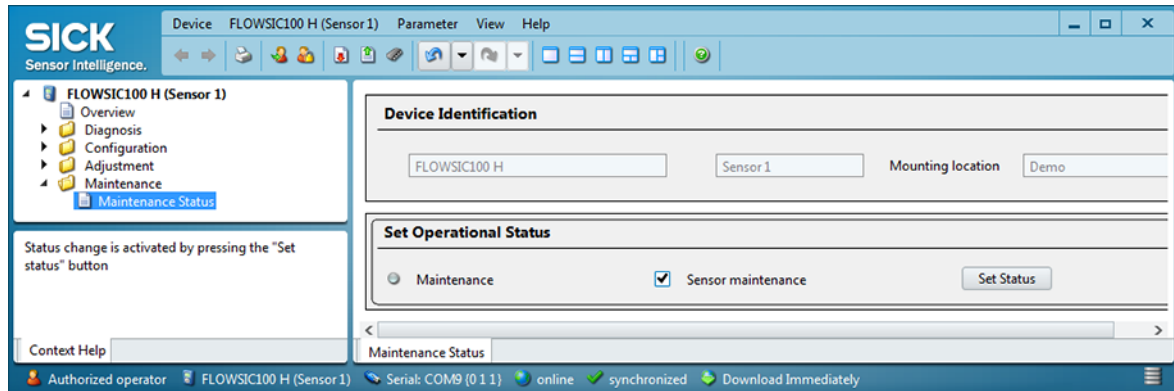

A control lamp signals the “Maintenance” state as follows:

- In the SOPAS menu “FLOWSIC100 X (Sensor) / Overview”,
- In the SOPAS status indicator in the field at the bottom left,
- On the display of the MCU control unit (only for MCU with display option).

4.2.2 Setting the system data parameters on the FLOWSIC100 sensor

- ▶ Open the device file “FLOWSIC100 X (sensor)” and enter the Level 1 password (→ p. 125, § 101).
- ▶ Set the maintenance mode (→ p. 127, § 4.2.1).

Basic requirements for every measurement are selecting the unit system (metric or imperial units) to be used and entering the application parameters (measuring path, installation angle, cross-sectional area). Select directory “Application Parameters” to enter settings (→ Fig. 103). The settings are uploaded to the FLOWSIC100 after switching from “Maintenance” to “Measurement”.



The application parameter settings are converted automatically when the unit system is changed.

The following is applicable for application parameters:

Measuring path	Distance between the transducers (L in Fig. 104)
Installation angle	Angle between the measuring axis and main direction of the gas flow (α in Fig. 104)
Cross-sectional area (required to calculate the volume flow)	Area in range of the ultrasonic transducer that is vertical to the flow direction and enclosed in the inner duct walls. If the cross-sectional area changes in the vicinity of the measurement setup, enter the mean value of the areas between the sender/receiver units A and B.

Fig. 103 Directory "Application Parameters" (settings example)

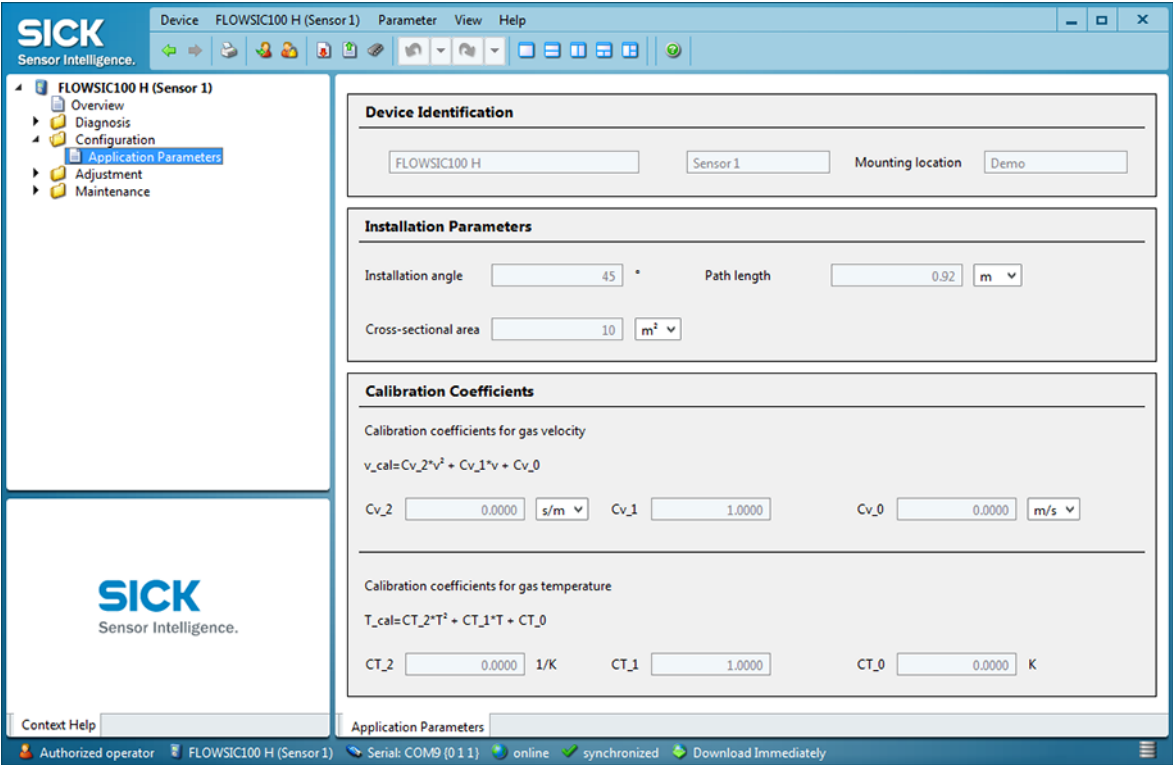

+i Entering the calibration coefficients → p. 144, 4.3

Fig. 104

Basic parameters

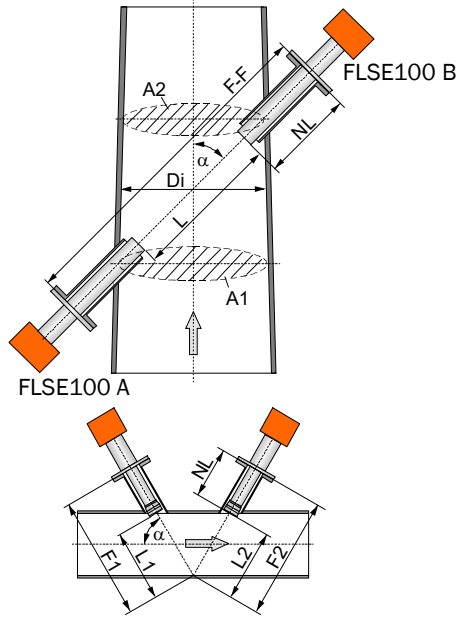

Cross-sectional area:

Circular ducts:

$$A = \frac{\pi}{4} \cdot D_i^2$$

Rectangular ducts:

$$A = a \cdot b$$

Cross-sectional changes

$$A = \frac{A_1 + A_2}{2}$$

Measuring path length:

$$L = FF - 2 \cdot NL$$

$$FF = F_1 + F_2$$

$$L = L_1 + L_2 = (F_1 + F_2) - 2 \cdot NL$$



For small duct dimensions < 0.5 m (short measuring paths), take the thickness of the seals used into account when determining measuring path L.

4.2.3 Setting the check cycle parameters

- ▶ Open the device file “MCU” and enter the Level 1 password (→ p. 125, Fig. 101).
- ▶ Set the maintenance mode (→ p. 127, §4.2.1).

Define the check cycle output in the “Adjustment/Function Check - Automatic” menu (→ Fig. 105). The function check can also be started manually.

Fig. 105 "Adjustment/Function Check - Automatic" menu

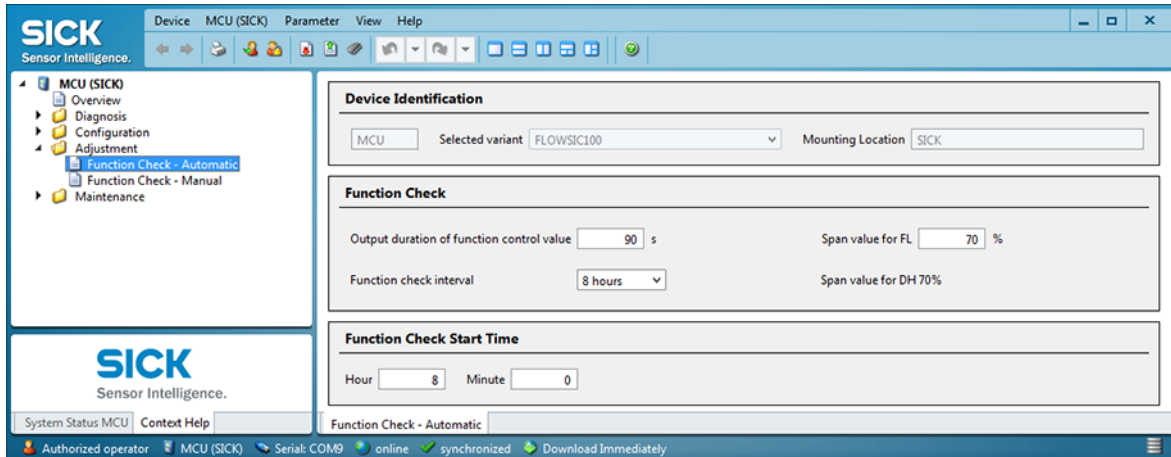

Field	Parameters	Remark
Output duration of function control value	Value in seconds	Output duration of the check value
Function check interval	Time between two check cycles	→ p. 47, §2.5
Span for control point	Value in % between 50% and 70%	→ p. 48, §2.5.2
Function Check Start Time	Hour	Defining a start timepoint in hours and minutes.
	Minute	

4.2.4 Configuring the analog output

Select MCU directory “Configuration / I/O Configuration / Output Parameters” (→ Fig. 106) to set the analog output.

Fig. 106 Directory “Output Parameter”

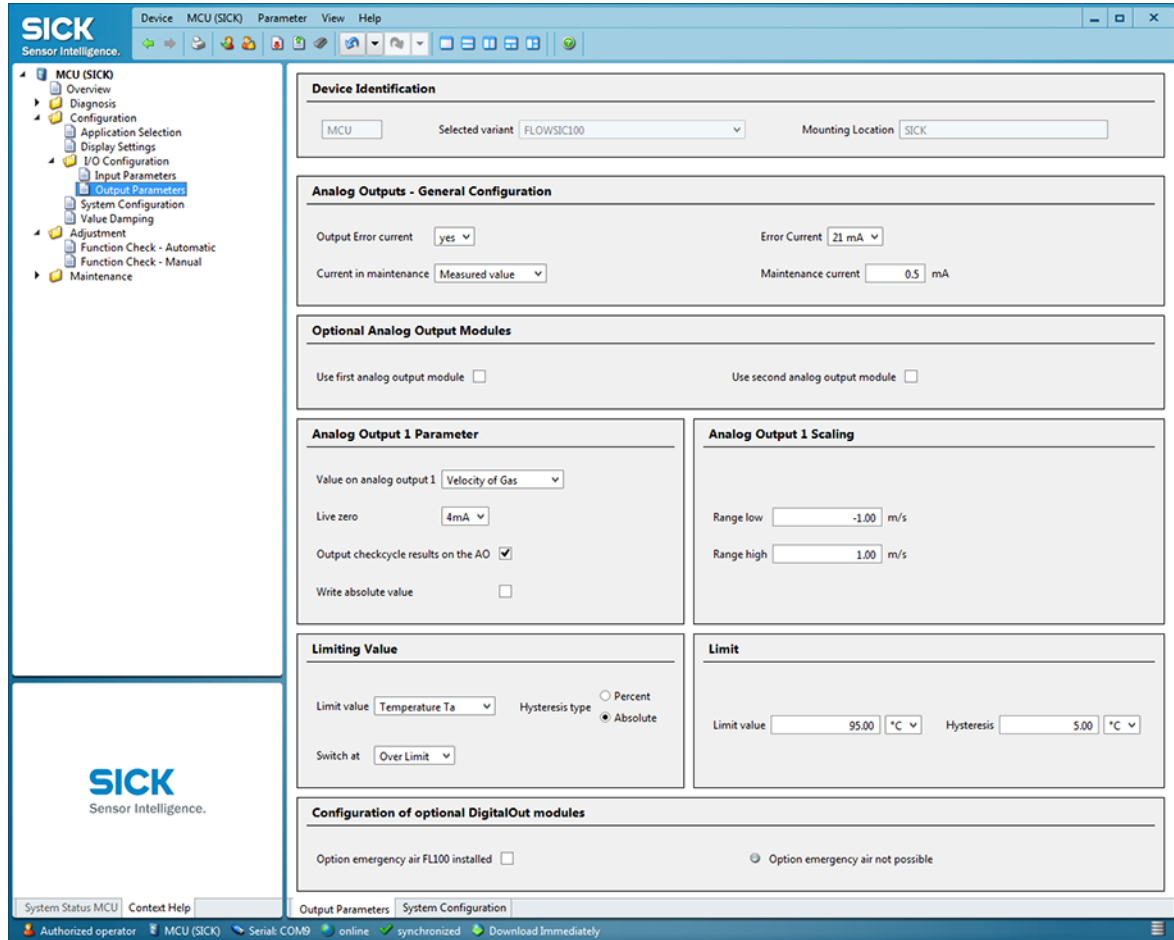

Field	Parameters	Remark	
Analog Outputs - General Configuration	Output fault current	Yes	The fault current is output
		No	The fault current is not output
	Differential current	Value > 20 mA	mA value to be output in case of malfunction Note Select a value < Live Zero when connected evaluation systems can only process the range 0 to 20 mA.
	Maintenance current	Last measured value	The last measured value is output during Maintenance mode
		User defined value	A value to be defined is output during Maintenance mode
		Measured value output	The current measured value is output during Maintenance Mode
Current at maintenance	Value if possible ≠ Live Zero	mA value to be output during Maintenance mode	

Subject to change without notice

Field		Parameters	Remark
Parameters Parameter 1	Source value	Velocity of gas	The selected measured variable is output on the analog output.
		Sound velocity	
		Q act.	
		Q std.	
	Range low	Pressure Source	External values for pressure, temperature and humidity, read via analog inputs, can be passed through and output on the analog output. Passing is selectable for the respective desired analog output.
		Temperature	
		Moisture Source	
Range high	Lower measuring range limit	Physical value at live zero	
Live zero	Upper measuring range limit	Physical value at 20 mA	
	Zero point (0, 2 or 4 mA)	Select 2 or 4 mA to differentiate clearly between measured value and device switched off, or current loop interrupted.	
Limiting value	Measured value	Velocity of gas	Selection of measured variable for monitoring a set limit value
		Sound velocity	
		Q act.	
		Q std.	
		Direction	
	Switch at		If a value $\neq 0$ is set, the limit value relay switches when the value for the selected measured variable is exceeded.
Optional digital output module configuration without function at present			

4.2.5 Configuring the analog inputs

Select MCU directory “Configuration / I/O Configuration / Input Parameters” (→ Fig. 107) to set the analog inputs.

Fig. 107 Directory “Input Parameter”

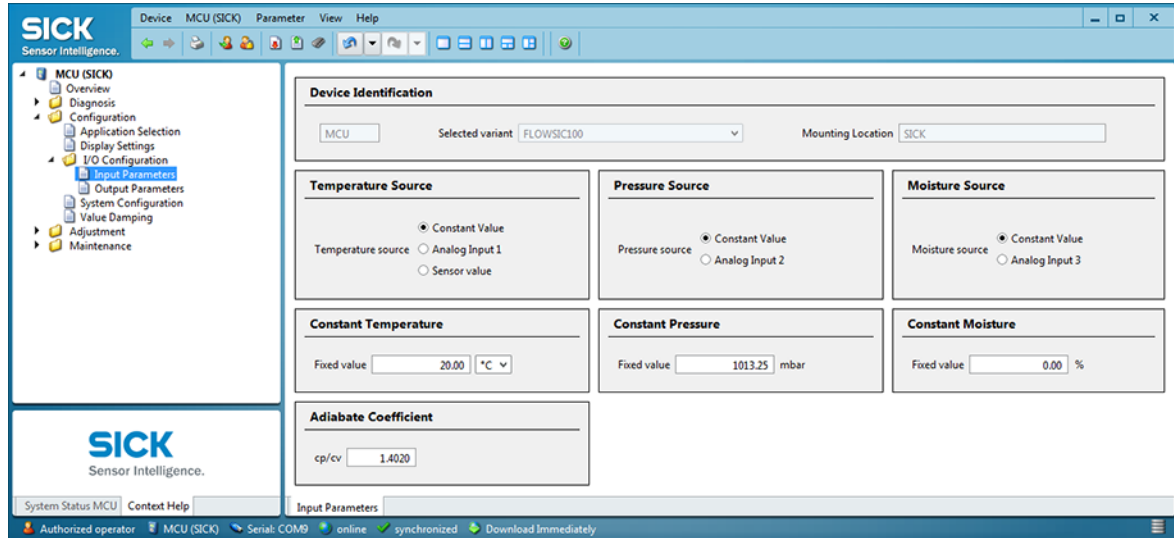

Field	Parameters	Remark
Temperature	Constant	A constant value is used for scaling.
	Analog Input 1	The value of an external sensor connected to analog input 1 (standard scope of delivery) is used for scaling. If this field is activated, the input field for configuring the input range appears under the “Temperature Source” field.
	Sensor value	The value of the integrated temperature sensor (Ta, Tb) or the value of the acoustic temperature (Tac.) is used for scaling.
Pressure Source	Constant	Fixed value
	Analog Input 2	The value of an external sensor connected to analog input 2 (standard scope of delivery) is used for scaling. If this field is activated, the input field for configuring the input range appears under the “Pressure Source” field.
Moisture Source	Constant	Fixed value
	Analog Input 3	The value of an external sensor connected to analog input 3 (optional module required) is used for scaling. If this field is activated, the input field for configuring the input range appears under the “Moisture Source” field.
Temperature Constant	Value in °C	Setting a value necessary for scaling
	Value in K	
Pressure Source Constant	Value in mbar	
Moisture Source Constant	Value in %	
Adiabate coefficient	Coefficient	Specific adiabatic coefficient

Subject to change without notice

4.2.6 Setting the damping time

The damping time can be configured in the MCU directory “Configuration / Value Damping” (→ Fig. 108).

Fig. 108 “Value Damping” submenu

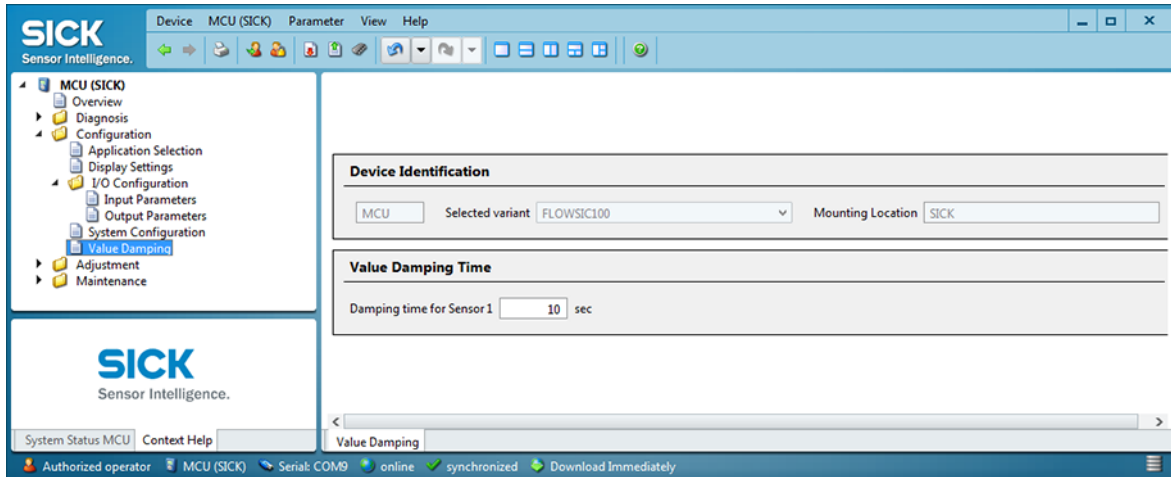

Field	Parameters	Remark
Damping time Sensor 1	Value in s	Damping time for the selected measured variable (→ p. 46, 2.4.3)
Damping time Sensor 2	Value in s	Damping time of additional sensors connected to the control unit (bus wiring)

4.2.7 Data backup

All parameters relevant for the collection, processing and input/output of measured values and current measured values can be saved and printed. This simplifies reentering set device parameters (e.g. after a firmware update) as well as registering device data or device states for diagnostic purposes.

The following options are available.

- Saving as project
Saving the data as a project allows saving not only device parameters but also data logs.
- Saving as protocol
Device data and parameter are recorded in the parameter protocol.
A diagnosis protocol can be generated for analyzing the device function and to identify possible malfunctions.

Saving as project

- ▶ Call up menu “Project / Save“ and specify the target directory and file name. The name of the file to be saved is freely selectable.

It is useful to specify a name with a reference to the respective sampling point (name of company and facility).



See Service Manual for description

Fig. 109 Menu “Project / Save“

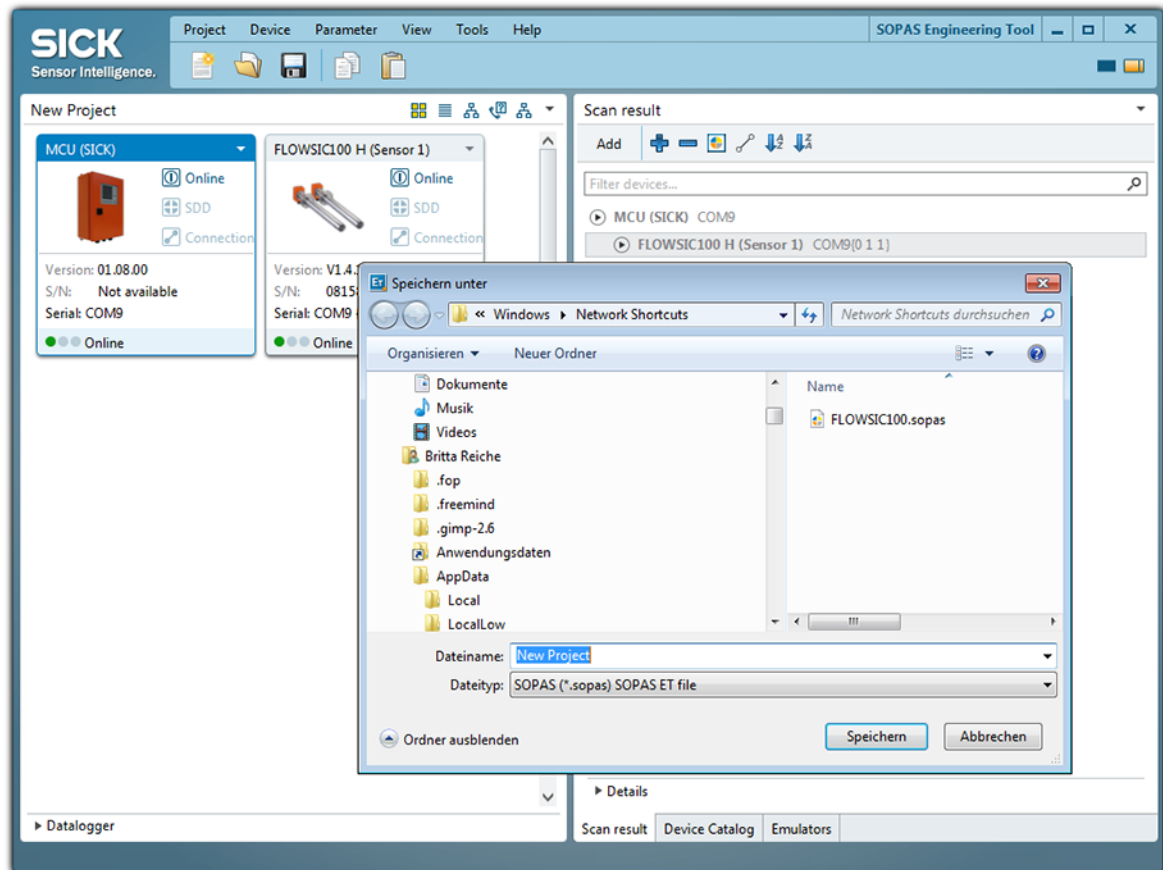

Saving as protocol

- ▶ Select a device, call up the “Diagnosis / Protocol” menu and click the button for the desired type of protocol.

Fig. 110 “Diagnosis / Protocol” menu

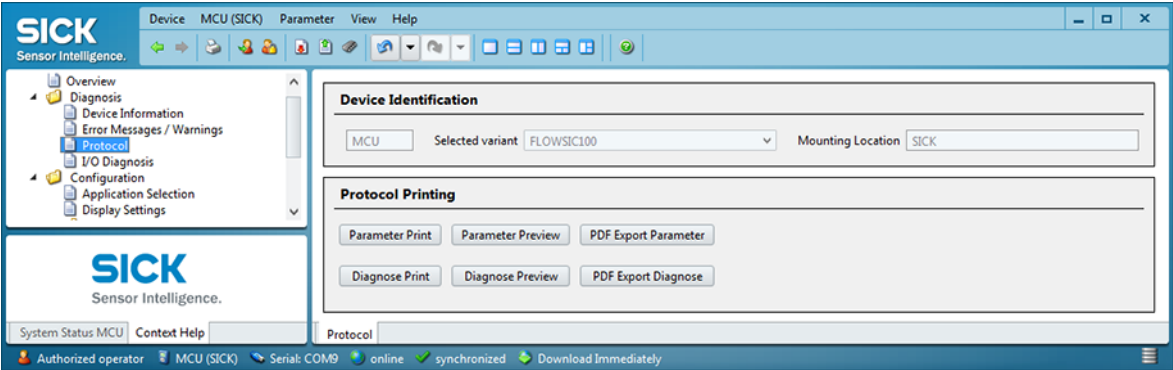

- ▶ Specify file names and storage location.

Fig. 111 Specifying file names and storage location

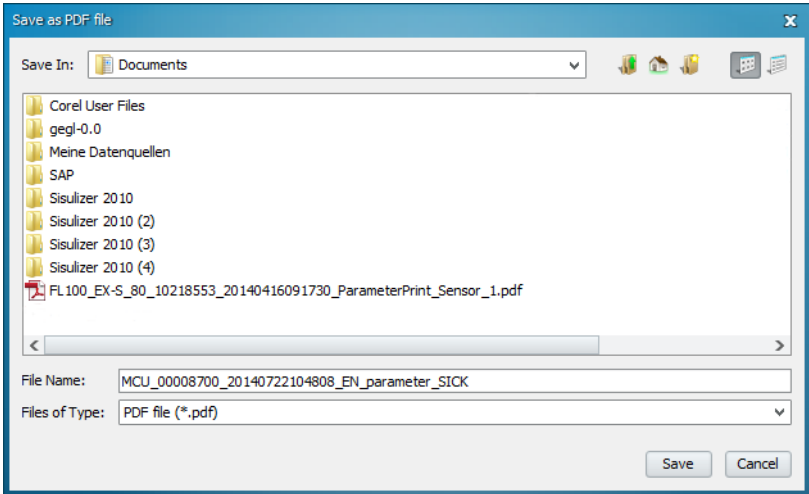

Example of a Parameter protocol

Fig. 112 MCU parameter protocol (example)

MCU Parameter Protocol - FL100 2 Path	
Device Type: MCU	
<i>Mounting Location: SICK</i>	
Device Information	
Device Type	MCU
Serial Number	00004711
Ident Number	00000
System Time	08 Nov 2009 22:03:46
Firmware Version	01.08.00
Hardware Version	1.5
Bootloader Version	00.99.xx
Calculation Values	
Sources	
Temperature Source	Analog Input 1
Pressure Source	Analog Input 2
Moisture Source	Constant Value
Constants	
Temperature Constant	20.00°C
Pressure Constant	1013.25mbar
Moisture Constant	50.00%
Adjustment	
Function Check Interval	8 hours
Function Check Output Duration	90s
Output Check Results on AO	yes
System Configuration	
Number of external AO	0
Number of external AI	0
Serial Expansion Module	Ethernet
Serial Expansion Module	
Type	Ethernet 10BaseT
Profibus Address	126
Modbus Address	1
IP Address	010.133.082.001
Subnet Mask	255.255.248.000
Gateway	000.000.000.000
TCP Port	2111
I/O Configuration	
Analog Output General Settings	
Error Current Selection	yes
Error Current Value	21 mA
Maint. Current Selection	User defined value
Maint. Current Value	0.50mA
Span Value	70%
Analog Output 1	
Live Zero	4mA
Limit Low	0.50
Limit High	1.87
Calibration factor CC0	0.0000
Calibration factor CC1	171.0000
Calibration factor CC2	0.0000
Source	Velocity of Gas (avg)
Analog Output 2	
Live Zero	4mA
Limit Low	-100.00
Limit High	100000.00
Source	Volume flow s.c. dry (avg)
Analog Output 3	
Live Zero	4mA
Limit Low	-20.00
Limit High	20.00
Source	Velocity of Gas (avg)
Analog Output 4	
Live Zero	4mA
Limit Low	0.00
Limit High	1.00
Source	Not Used
Analog Output 5	
Live Zero	4mA
Limit Low	0.00
Limit High	1.00
Source	Not Used
Analog Input 1 (Temperature)	
Limit Low	0.00°C
Limit High	200.00°C
Calibration factor CC0	0.0000
Calibration factor CC1	0.0204
Calibration factor CC2	0.0000
Analog Input 2 (Pressure)	
Limit Low	0.00mbar
Limit High	1100.00mbar
Calibration factor CC0	0.0000
Calibration factor CC1	0.0204
Calibration factor CC2	0.0000
Analog Input 3 (Moisture)	
Limit Low	0.00%
Limit High	0.00%
Limit Switch	
Source	Velocity of Gas (avg)
Limiting Value	1.87
T90 Time	
T90 Time FL Path 1	1.0s
T90 Time FL Path 2	1.0s

Subject to change without notice

4.2.8 Starting normal measuring operation

Set the measuring system to “Measurement” mode after entering or modifying parameters. By deactivating the maintenance mode, the normal measuring operation is started:

- ▶ Open the directory “Maintenance/Maintenance Status”.
- ▶ Deactivate the checkbox “Maintenance” (MCU) or “Sensor maintenance” (sender/receiver unit) and click “Set Status”.

Fig. 113 Starting measurement mode

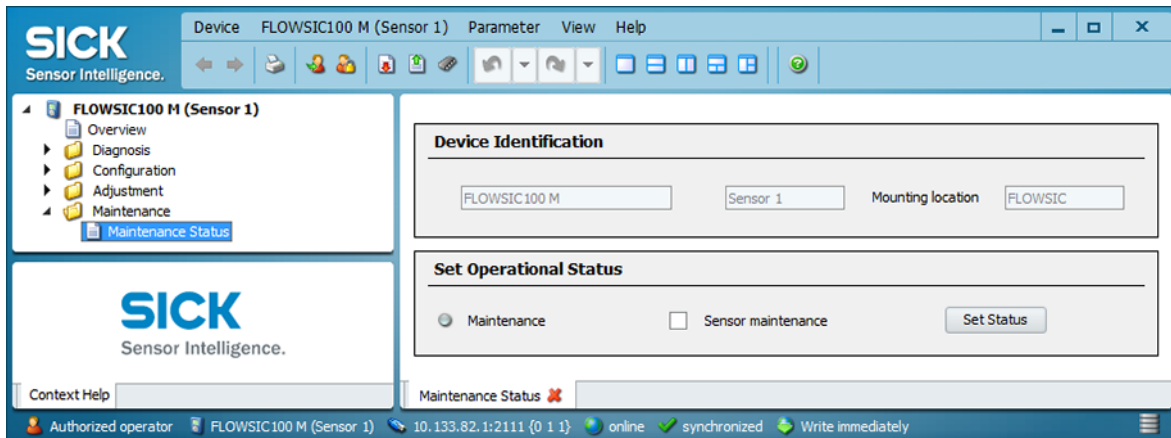

Standard start-up is now completed.



NOTICE:

For internally cooled and purged sender/receiver units, the purge air supply has to be guaranteed during facility downtime. Otherwise remove the sender/receiver units from the duct.

4.2.9 Signal waveform

Checking the signal waveform allows an assessment on the quality of the received ultrasonic signals.

- ▶ To enable the display on the screen, open the device file of the used FLOWSIC100 type.
- ▶ Select the menu “Diagnosis/Sensor Values” in operating mode “Measurement”.
- ▶ The ultrasonic signals of both transducers are displayed as unconditioned signals under “Signal Display”. If the option “View Envelope” is checked, the envelopes of both transducers are displayed. The signal waveform should match the waveforms in the Fig. 114 to Fig. 123, depending on the device type.

Type FLSE100-M /MAC

Fig. 114 Burst waveform HF signal (unconditioned signal)

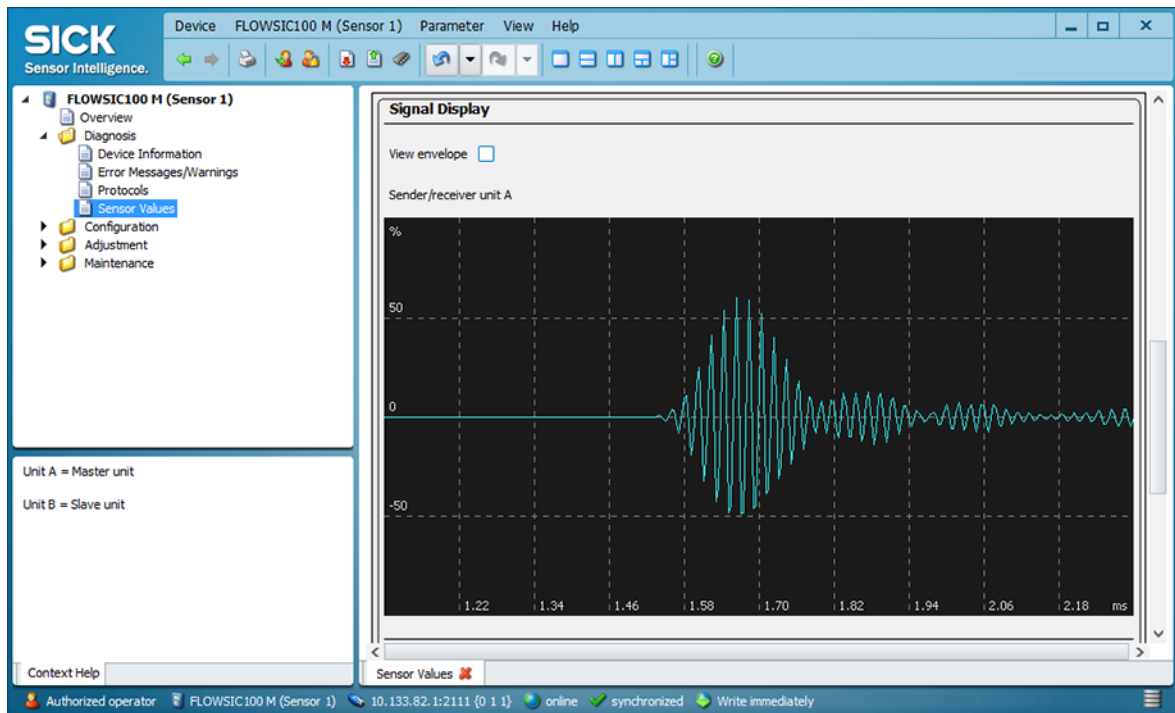
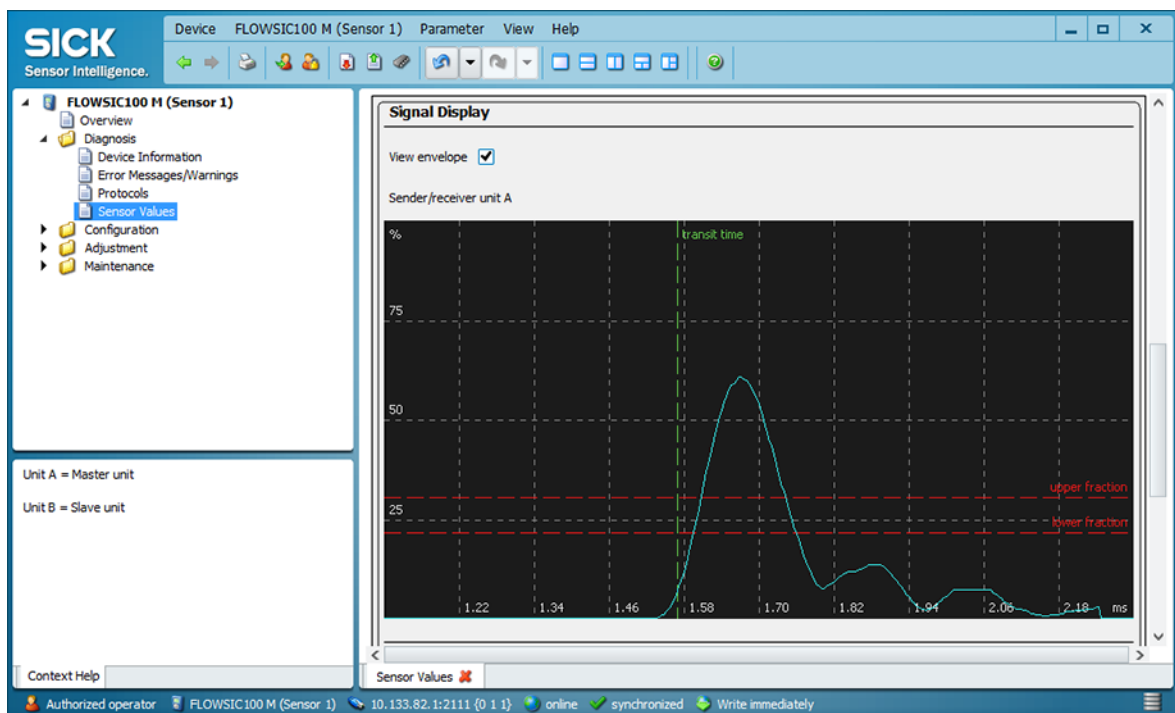

Fig. 115 Burst waveform demodulated signal (envelope)



Subject to change without notice

Type FLSE100-H / HAC / PHS

Fig. 116 Burst waveform HF-signal (unconditioned signal)

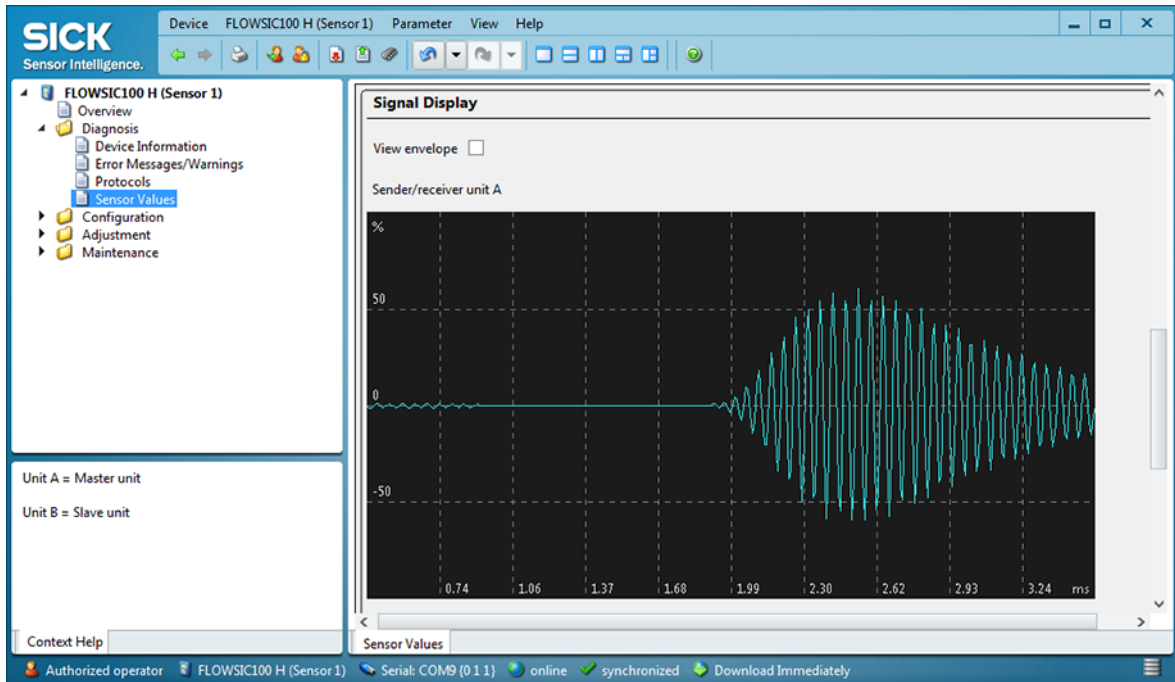
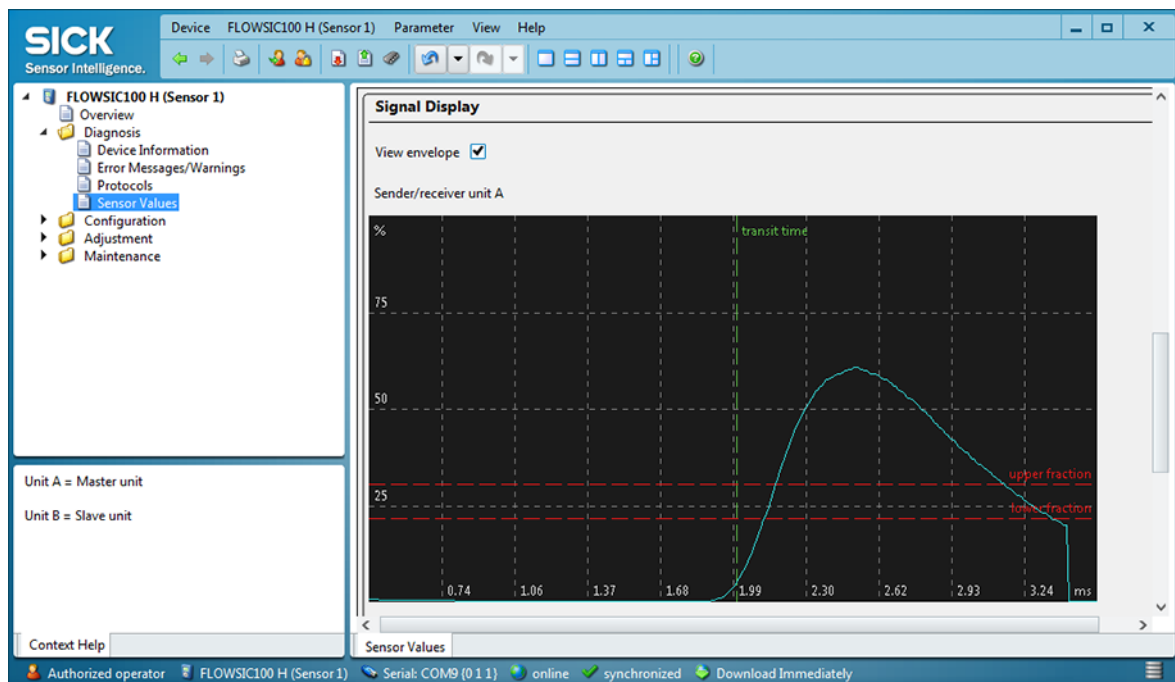

Fig. 117 Burst waveform demodulated signal (envelope)



Subject to change without notice

Type FLSE100-PH

Fig. 118 Burst waveform HF-signal (unconditioned signal)

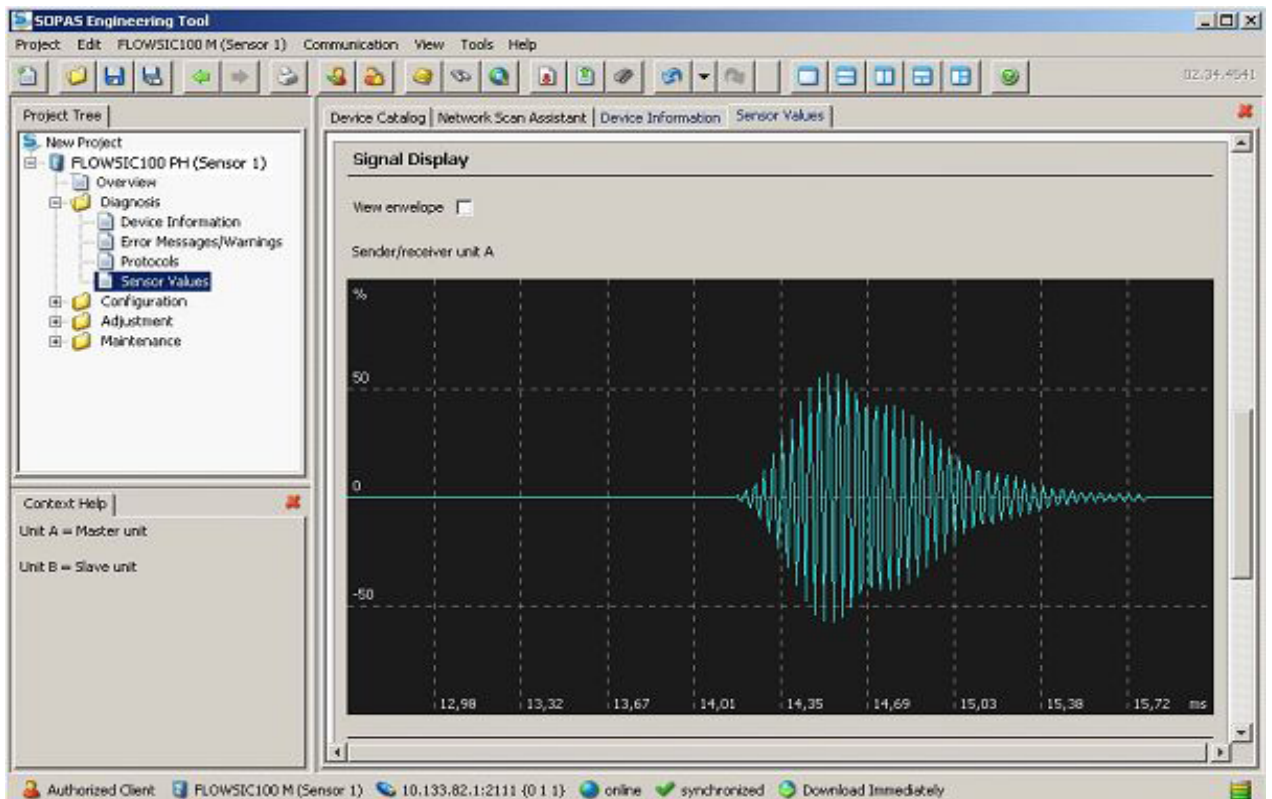
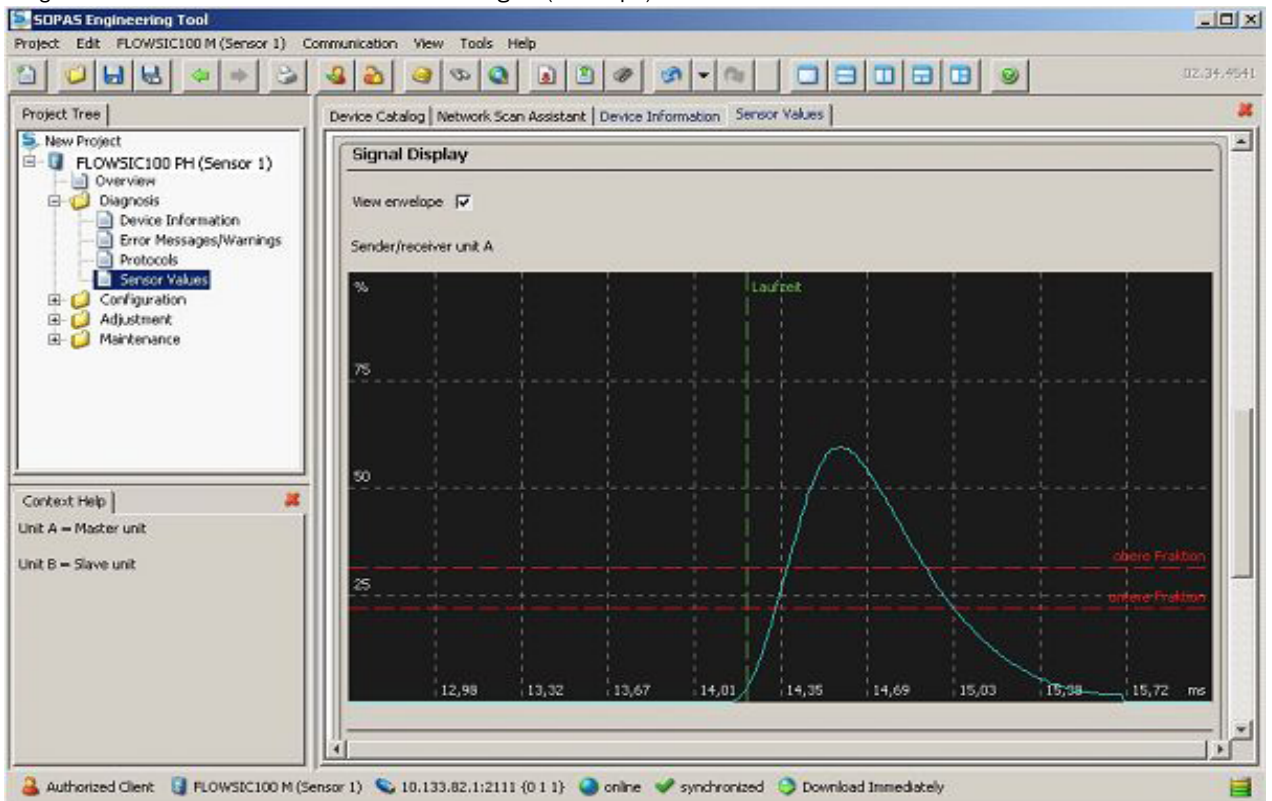

Fig. 119 Burst waveform demodulated signal (envelope)



Subject to change without notice

Type FLSE100-S

Fig. 120 Burst waveform HF-signal (unconditioned signal)

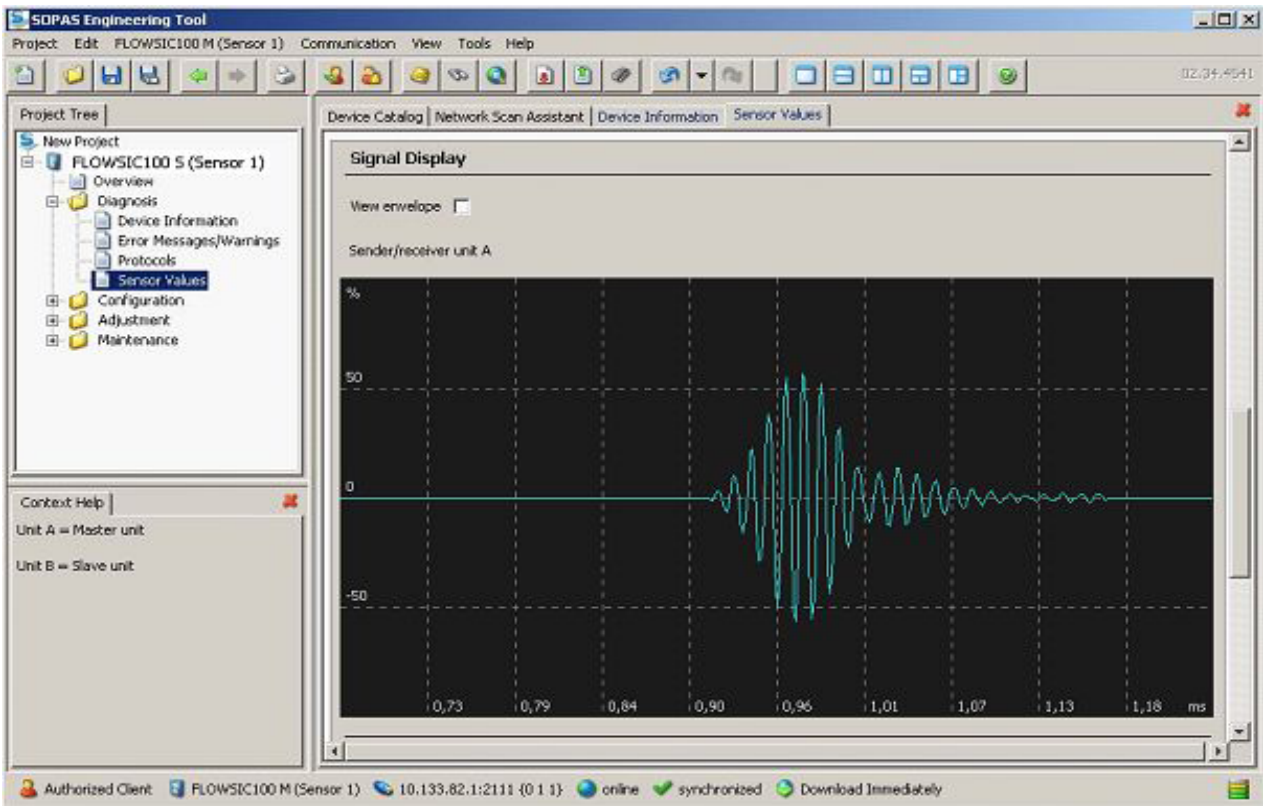
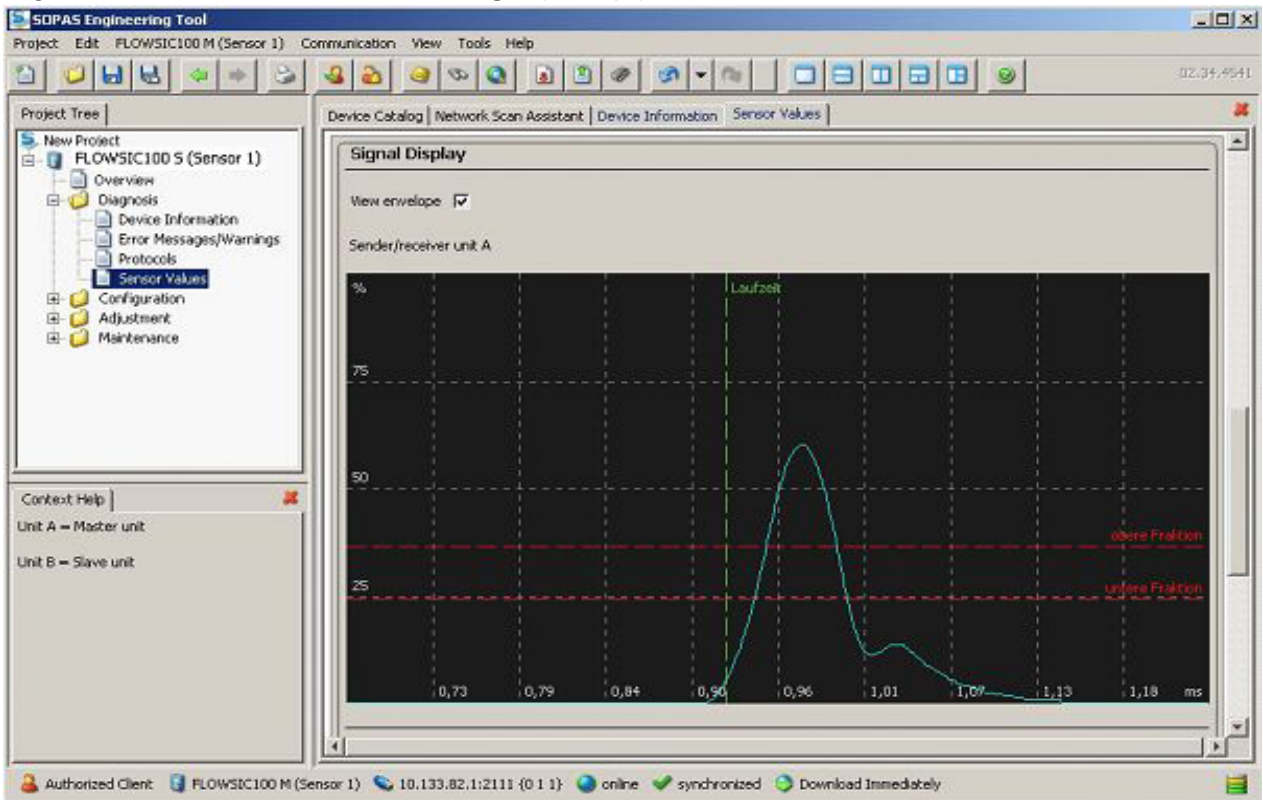

Fig. 121 Burst waveform demodulated signal (envelope)



Subject to change without notice

Type FLSE100-PR

Fig. 122 Burst waveform HF-signal (unconditioned signal)

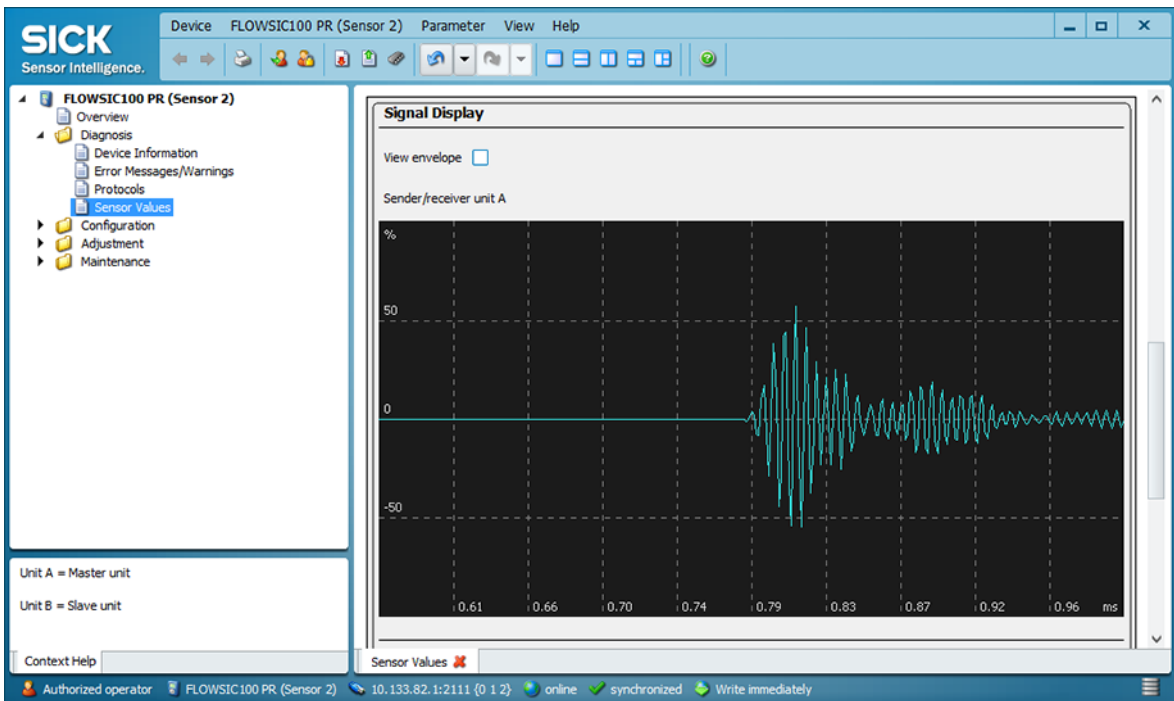
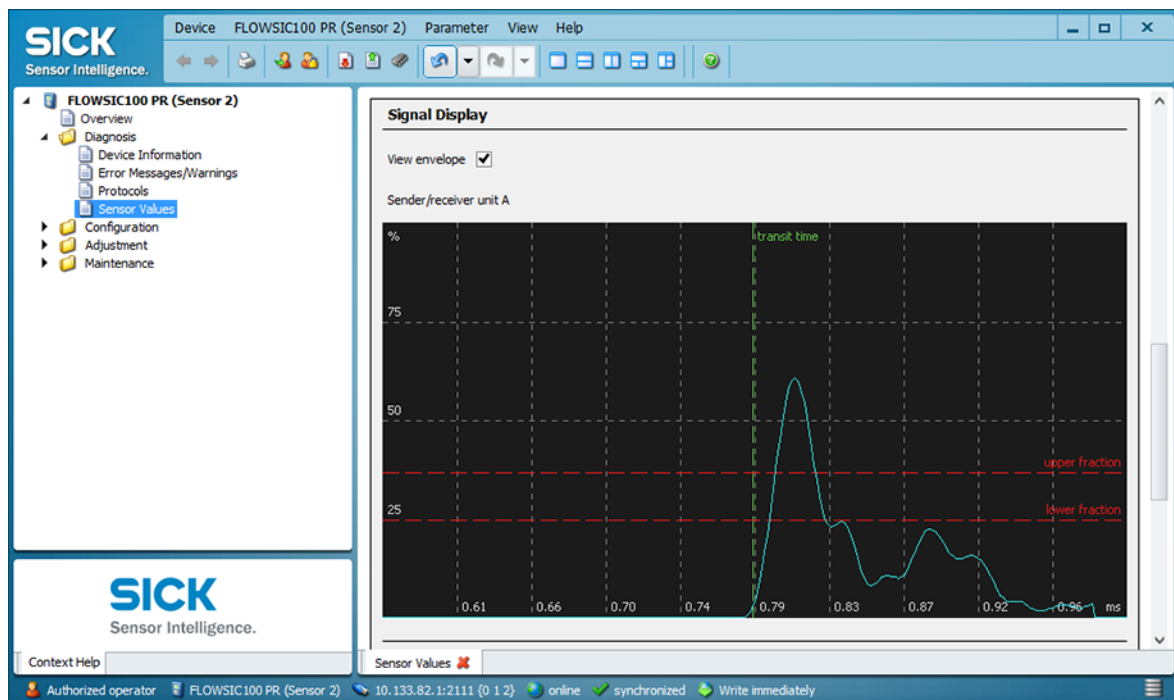

Fig. 123 Burst waveform demodulated signal (envelope)



Subject to change without notice

4.3 Advanced start-up

4.3.1 Changing the application setting

The FLOWSIC100 supports measuring on two measuring paths at the same time and then calculating and outputting one common measured value → p. 14, 2.2.2. This requires 2 sender/receiver units per measuring path or one measuring probe each → »Installation« (page 78). The necessary settings are usually made at the factory. If this is not the case (e.g. if existing devices are retrofitted), carry out the following procedure:

- ▶ Open the device file “MCU”, set the measuring system to “Maintenance” mode and enter the Level 1 password (→ p. 126, 4.2).
- ▶ Select directory “Configuration / Application Selection”. The basic type of the sender/receiver unit connected is displayed in the “Connected Variant” window (field “Application setting”).
- ▶ Click “Save selection” to assign to the MCU.



The sender/receiver unit must be connected to the MCU.

Fig. 124 Setting the MCU to the sender/receiver unit

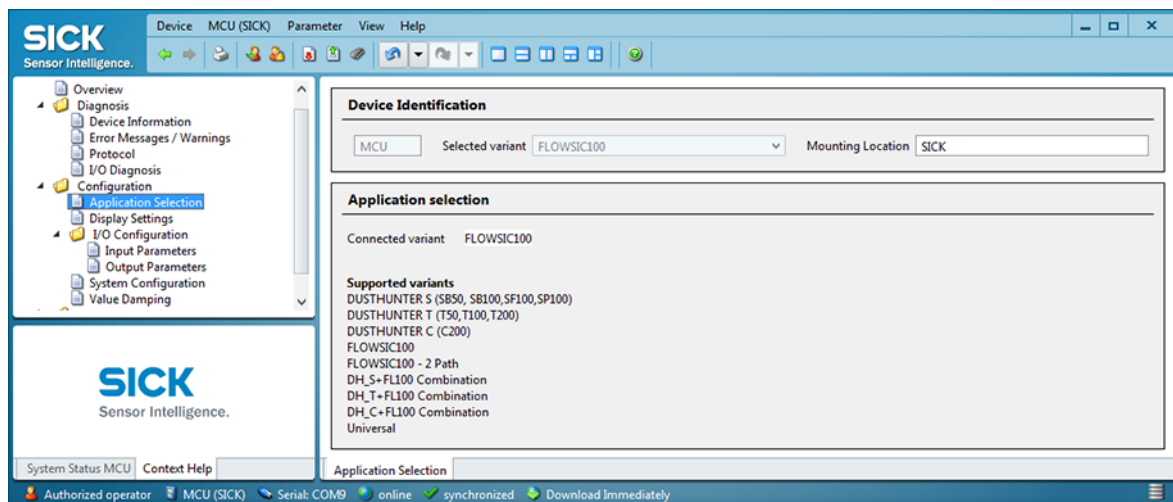

- Per default, all measuring paths have the same weighting in the calculation of the output value (for changing the weighting, see Service Manual).
- The FLOWSIC100 has a function for automatic path compensation should one measuring path in a 2-path configuration fail → p. 15, 2.2.3.
- Setting parameters for application settings can also be done via the LC-Display → p. 154, 4.4.4.

4.3.2 Configuring optional analog modules

Analog output module

The basic settings (field “Analog Outputs - General Configuration”) apply to all additional analog outputs.

+i Maximum 4 AO are also available (2 AO modules each with 2 outputs)

To set the parameters, carry out the following procedure:

- ▶ Select the MCU type in the project window, enter the Level 1 password and switch the measuring system to “Maintenance” → p. 126, 4.2.
- ▶ Select directory “Configuration / I/O Configuration / Output Parameter” (see → Fig. 125).
- ▶ Activate the checkbox “Use first analog output module”.
- ▶ New dialog boxes for “Analog Output 2 Parameter” and “Analog Output 3 Parameter” are opened.
- ▶ Configure the optional analog outputs according to the requirements in § 4.2.4.

Fig. 125 Configuring the optional analog outputs

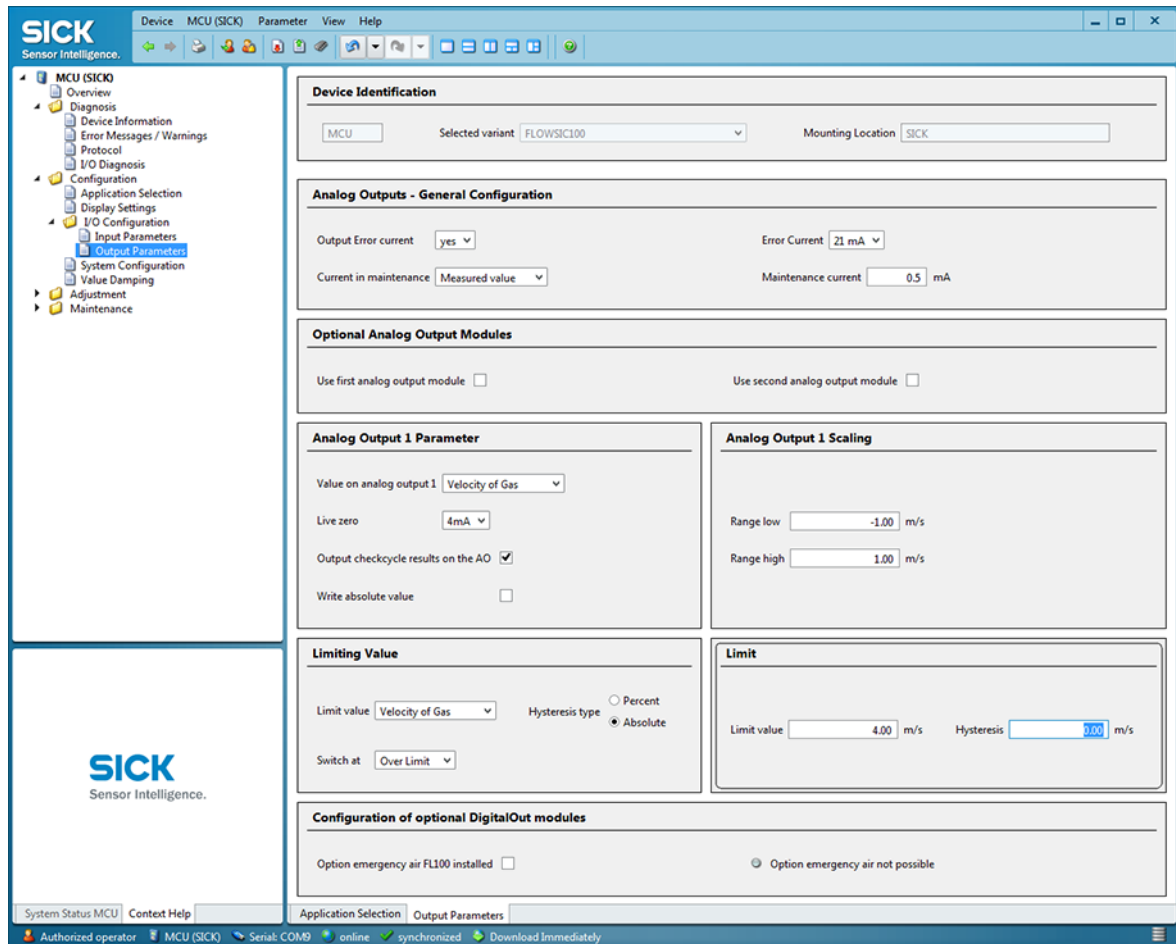

Subject to change without notice

- ▶ To configure further analog outputs, activate the checkbox “Select optional module / use first or second optional module”.
The boxes to set the parameters for further analog outputs 2/3 or 4/5 are open for input.
- ▶ Set the parameters for further analog outputs as described for setting the parameters for the first analog output.

4.3.3 Configuring the optional interface module

 For detailed information on the individual modules see „Interface Documentation FLOWSIC100“.

The following steps are required for selecting and configuring the optionally available interface module:

- ▶ Select device file “MCU”, set the measuring system to “Maintenance” mode and enter the Level 1 password (→ p. 124, Table 3).
- ▶ Select directory “Configuration / System Configuration”.
The installed interface module is displayed in the field “Installed Interface Module”.
- ▶ Configure the interface module according to requirements.

Fig. 126 “Configuration / System Configuration” directory

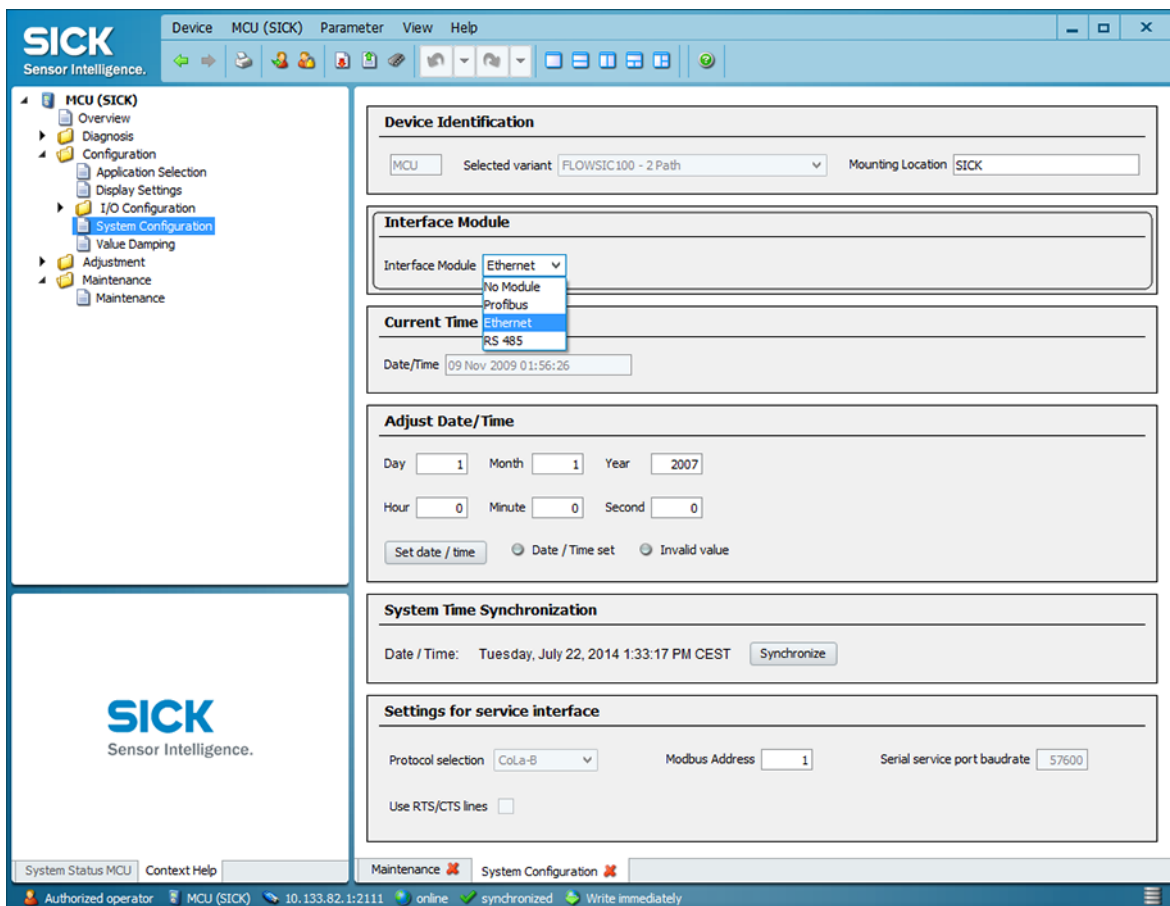

 GSD file and measured value assignment are available for the Profibus DP module on request.

4.3.4 Configuring the Ethernet module

**NOTICE:**

There is a risk of undesired access to the measuring system during communication via Ethernet.

- ▶ Only operate the measuring system behind suitable protection devices (e.g.: Firewall).

Assigning the Ethernet module a new IP address

An IP address specified by the customer is entered at the factory when the address is available when the device is ordered. If not, standard address 192.168.0.10 is set.

Complete the following procedure to change the address:

- ▶ Select directory “Configuration / I/O Configuration / Interface Module”.
- ▶ Set the desired network configuration in the “Ethernet Interface Configuration” field and click “Reset module” under “Expansion module information”.

Fig. 127 “Configuration / I/O Configuration / Interface Module” directory

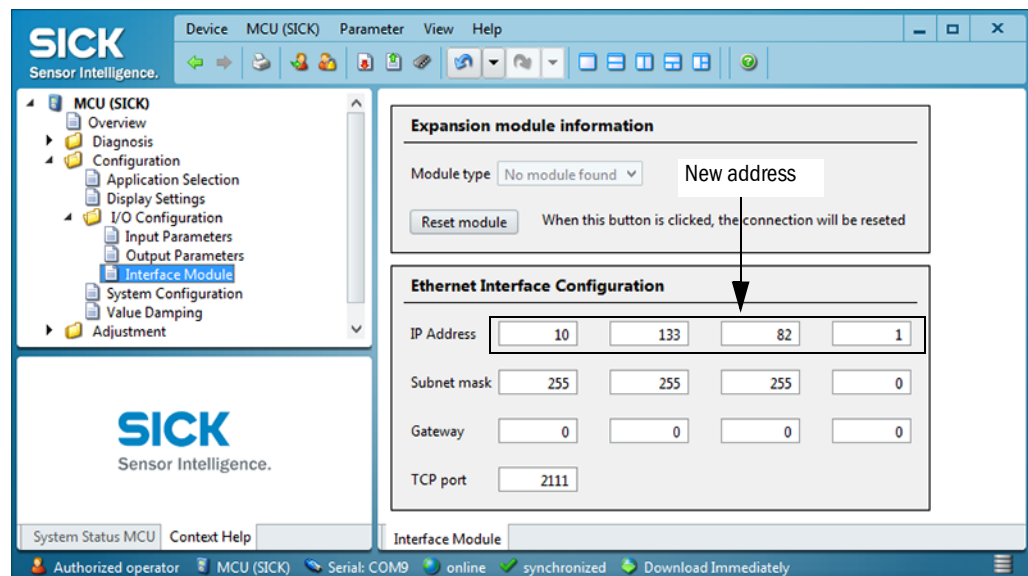

Assigning a new IP address using SOPAS ET

- ▶ Connect the device → p. 116, §4.1.3.

**NOTICE:**

Malfunctions in data transfers not caused by the measuring system can occur during communication via Ethernet.

- ▶ The FLOWSIC100 manufacturer assumes no responsibility for malfunctions that may occur during equipment operation when measured value transfers and their usage to control processes run solely via Ethernet.

Increasing the value in the “Scan timeout” field to 3000 ms can minimize communication problems.

4.3.4.1 **Changing the field bus address for the Profibus module**

The Profibus DP interface module is set to field bus address 126 at the factory. Complete the following procedure to change the address:

- ▶ Check in the “Configuration / System Configuration“ directory (→ p. 146, Fig. 126) that the interface module (field “Interface Module”) is set to “Profibus DP”.
- ▶ Select the “Configuration / I/O Configuration / Interface Module“ directory and enter the new address in the “Fieldbus address” window (field “Profibus DP Configuration”).

Fig. 128 “Configuration / I/O Configuration / Interface Module” directory

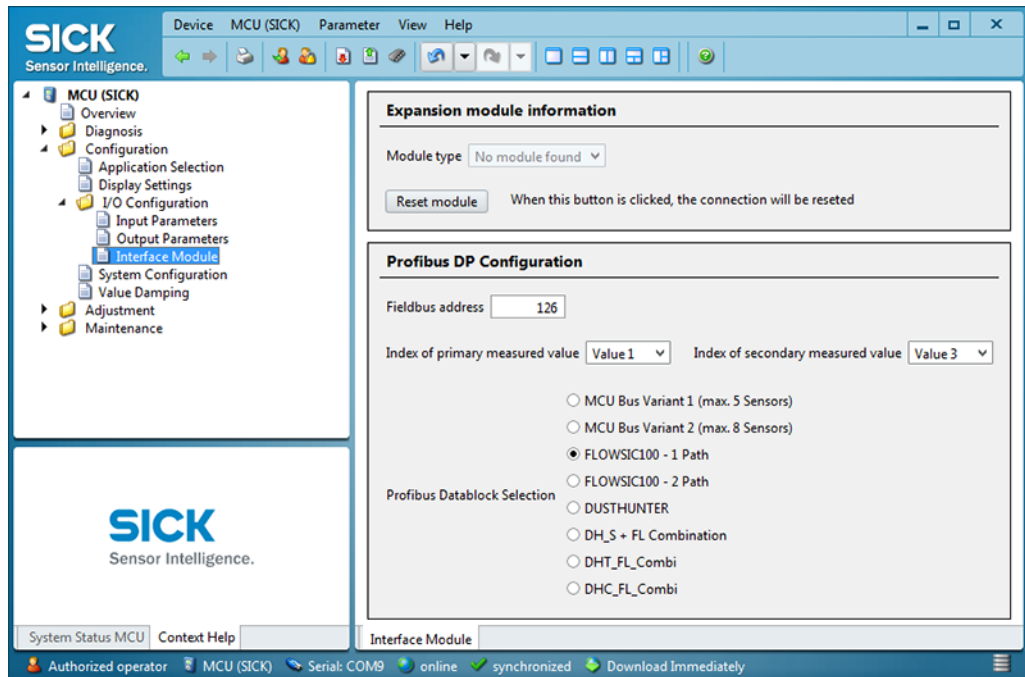

4.3.5 Configuring the temperature curve for the cooling air control option for device types M-AC and H-AC



NOTICE:

A firmware update is necessary for MCU firmware versions older than 1.0.50.

- ▶ Select device file “MCU”, set the measuring system to “Maintenance” mode and enter the Level 1 password (→ p. 124, Table 3).
- ▶ Select directory “MCU/Configuration/I/O Configuration/Output Parameters” and set the temperature limit “Ta” or “Tb” for the sender/receiver unit. The temperature limit should be approx. 20 K above the gas dew point (+150 ... +180 °C), the hysteresis should be approx. 2 °C.

Fig. 129 Temperature limit configuration

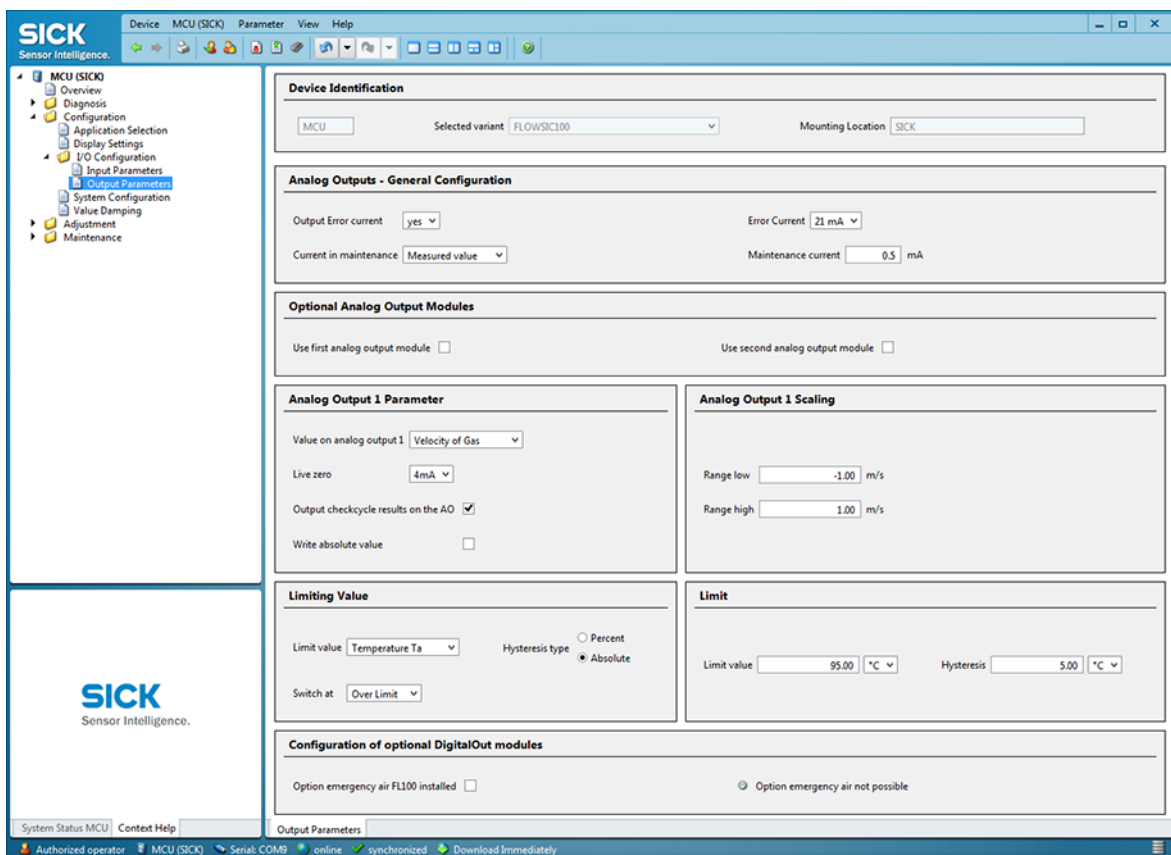

Cooling air control function check

- ▶ Set the temperature limit close to the ambient temperature of the S/R units and check whether the cooling air control switches on and off.

4.3.6

Calibrating flow rate and temperature measurement

This Section describes parameter settings that are necessary for calibrating gas flow rate and temperature measurements, and for outputting the volume flow in the standard state. To do this, set the measuring system to “Maintenance” mode and enter the Level 1 password. For input, select type FLOWSIC100 in the “Device Catalog” register, field “Detected Devices” (→ p. 124, Table 3) and then select subdirectory “Installation Parameters”.



Refer also to → p. 44, 2.4

Entering calibration coefficients for gas flow rate measurement

Enter the calibration coefficients determined with a network point measurement using a reference system in the group “Calibration coefficients / Calibration coefficients for flow rate”.

Default values from the factory are $Cv2 = 0$, $Cv1 = 1$, $Cv0 = 0$.

Calibrating temperature measurements

The accuracy of the acoustic temperature measurement with the FLOWSIC100 depends quadratically on the active measuring path and sound velocity of the real gas under standard conditions (→ p. 15, 2.2.3). Exact acoustic temperature measurements are only possible when the sound velocity of the real gas remains constant at a reference temperature. Since this is seldom the case, the internal temperature calculation in the device must be calibrated if it is to be used to scale the volume flow.

To calibrate the measurement, determine the value pairs from separately measured gas temperature (for example, with PT100 sensor) and display on the LC-Display at a minimum of two different gas temperatures. Convert the calculated values to absolute temperatures (add 273.15 K). Then use a regression function to calculate the coefficients (for two pairs by linear, with more value pairs also by quadratic regression). Enter CT_2, CT_1 and CT_0 in the “Calibration coefficients / Calibration coefficients for temperature” group.

Default settings from the factory are $CT_2 = 0$, $CT_1 = 1$, $CT_0 = 0$.

Example:

Measurement	FLOWSIC display		Measured value PT100	
	T in °C	T _{absolute} in K	T in °C	T _{absolute} in K
1	128	401	115	388
2	186	459	170	443

$$T_{KAL} = CT_1 \cdot T_{FLOWSIC} + CT_0$$

$$CT_1 = \frac{T_{2PT100} - T_{1PT100}}{T_{2FLOWSIC} - T_{1FLOWSIC}}$$

$$CT_0 = \frac{1}{2} \cdot (T_{2PT100} + T_{1PT100} - CT_1 \cdot (T_{2FLOWSIC} + T_{1FLOWSIC}))$$

$$CT_1 = 0.9483$$

$$CT_0 = 7.7310$$

4.4 Operating / Configuring with the LC-Display option

4.4.1 General information on use

The display and operation interface of the LC-Display contains the functional elements displayed in Fig. 130.

Fig. 130 Functional elements LC-Display

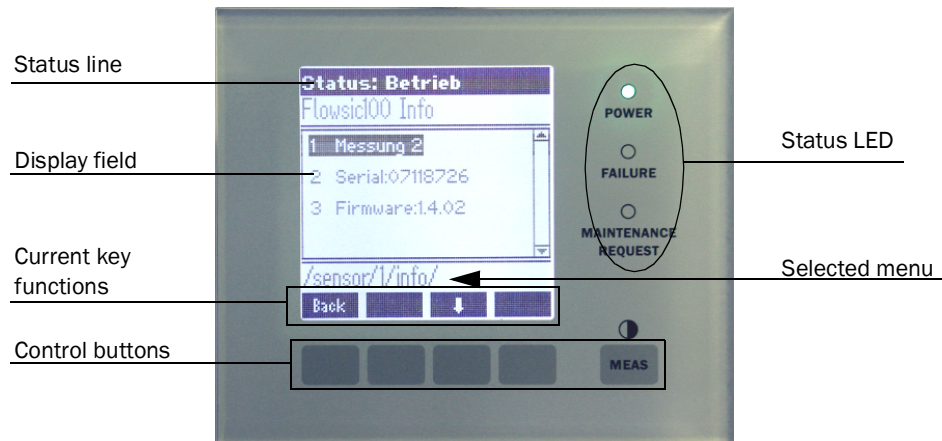

Key functions

Key functions depend on the current selected menu. Only the function currently displayed over the key is available.

Button	Function
Diag	Displays diagnostic information (warnings and errors during a start using the Main menu, sensor information during a start using the Diagnostics menu; see → p. 153, Fig. 131) This function is only active when warnings or malfunctions are present.
Back	Returns to the next higher level
Arrow ↑	Scrolls up
Arrow ↓	Scrolls down
Enter	Starts the action selected with the arrow keys (go to submenu, confirmation of selected parameter during configuration)
Start	Starts an action
Save	Saves a changed parameter
Meas	Selects the single measured value to be displayed Toggles between text and graphic display Returns to main menu from submenus Displays the contrast settings (after 2.5 s)

4.4.2 Menu structure

Fig. 131 Menu structure of LC-Display

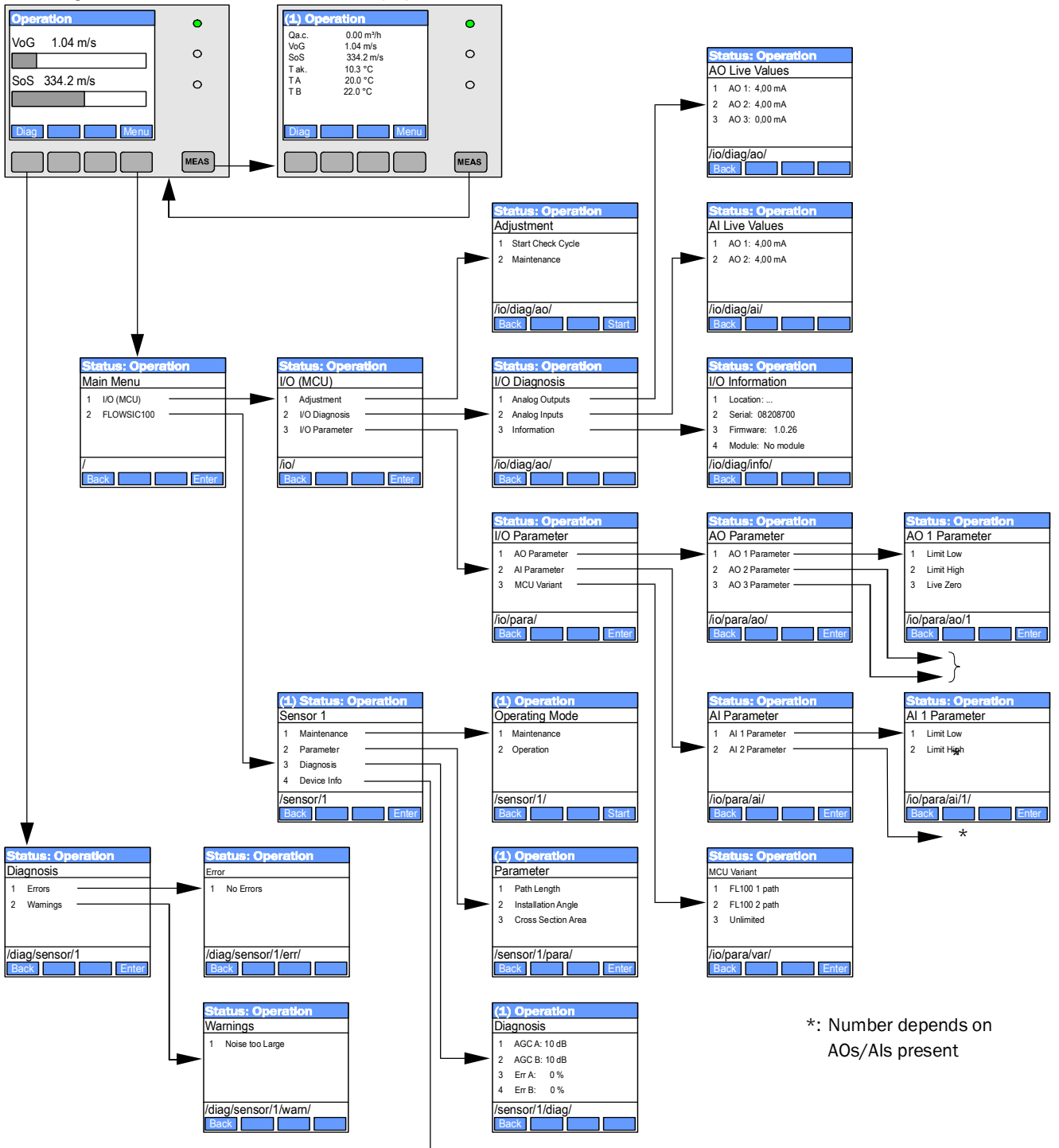

Subject to change without notice

4.4.3 **Configuring**

Parameters for input / output (analog input / output) or installation (measuring path length, installation angle, duct diameter) can be changed with the following procedure:

- ▶ Go to the appropriate submenu, select the line “Limit Low” or “Limit High” and press “Enter”
The valid range is displayed in the fields “Min” and “Max”
- ▶ Enter the default password “1234” with the keys “^” (scrolls from 0 to 9) and/or “→” (moves the cursor right).
- ▶ Select the desired value for “Min” and “Max” with the keys “^” and/or “→” and confirm with “Save”.
The selected value is saved to the device.

Fig. 132 Menu structure for configuration

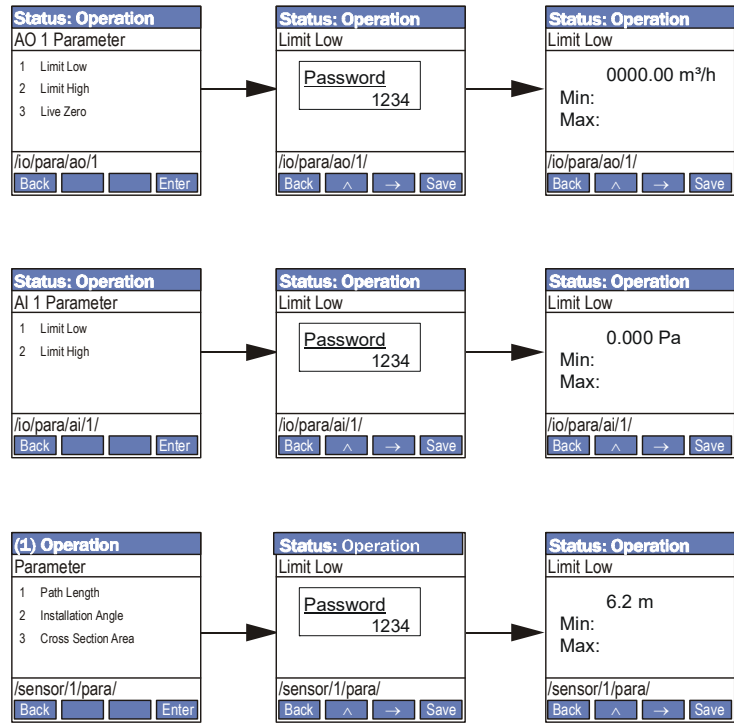

4.4.4 **Changing the application setting**

- ▶ In the menu “I/O (MCU)” select submenu “I/O Parameter”, select line “MCU Variant” and confirm with “Enter”.
- ▶ Select “FL100 2 path” in the “MCU Variant” submenu and confirm with “Enter”.

Fig. 133 Menu structure for selecting two-path measurement

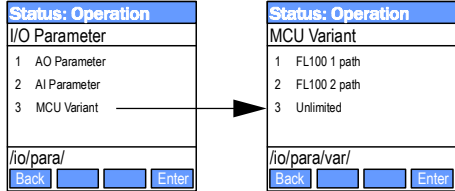

Subject to change without notice

4.4.5 Changing the display settings with SOPAS ET

To change the factory settings, select the device file “MCU”, enter the Level 1 password and select the “Configuration / Display Settings” menu.

Fig. 134 "Configuration / Display Settings" menu

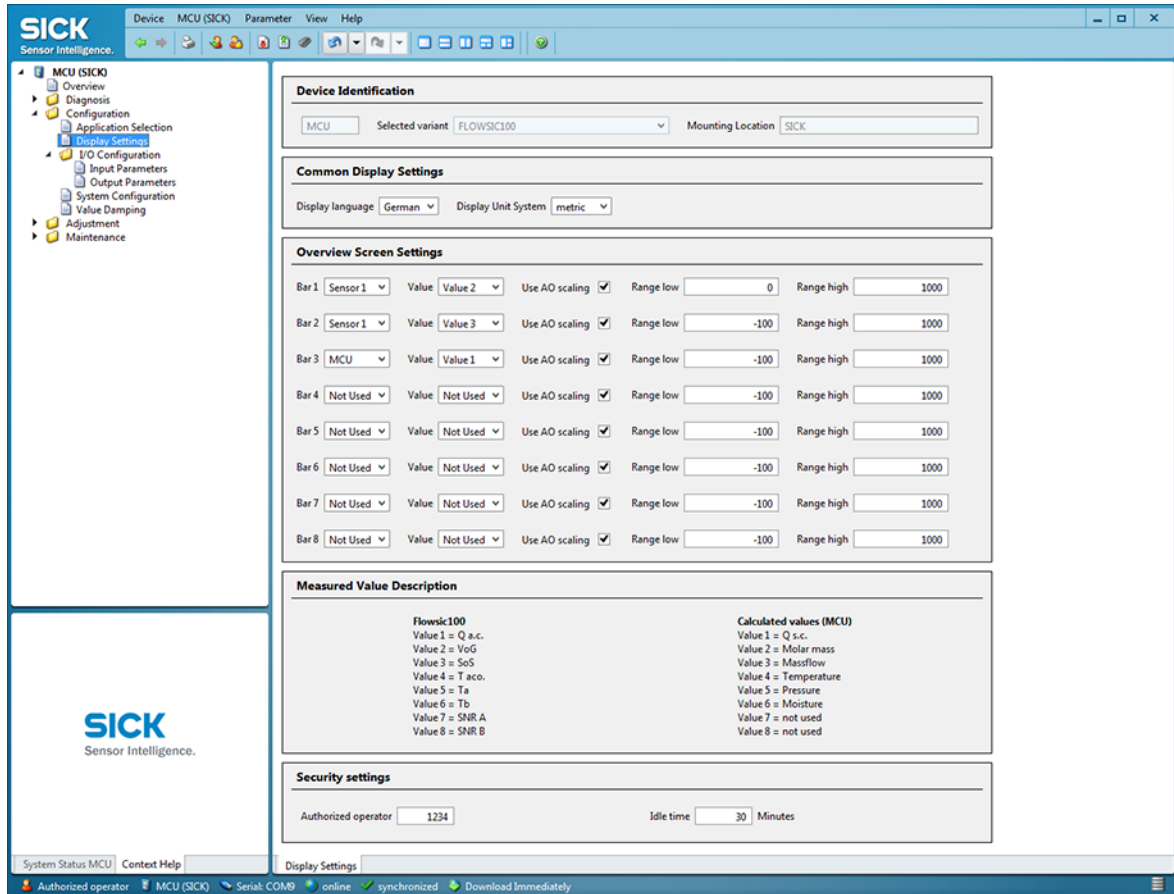

Field		Significance
Common Display Settings	Display language	Language used on LC-Display
	Display Unit System	Unit system used on LC-Display
Overview Screen Settings	Source Sensor (1) to (8)	Sensor address for the first measured value bar of the graphic display
	Source Value	Measured value index for the first measured value bar
	Use AO scaling	If active, the measured value bar of the corresponding analog output is scaled. If the checkbox is not checked, the limit values must be defined separately.
	Range low	Values for the separate scaling of the measured value bar, independent of the analog output
Range high		

Subject to change without notice

FLWSIC100

5 Maintenance

General information

Maintaining the sender/receiver units

Maintaining the cooling air supply of the internally cooled types M-AC and H-AC

Maintaining the external purge air unit accessory

Maintaining the external purge air unit accessory

5.1 General information

Maintenance strategy

Just like any other electronic measuring system, the FLOWSIC100 requires regular maintenance. By inspecting the system regularly and replacing wear-and-tear parts in good time, the service life of the device can be lengthened significantly and ensures measurements are always reliable.

Even though the FLOWSIC100 is often deployed in harsh environments, its design and measuring principle are such that the device requires only minimal maintenance.

Maintenance tasks

The maintenance tasks are limited to:

- Sender/receiver unit
- Cooling air/purge air unit (only necessary for cooled/purged sender/receiver units)

Before you carry out these maintenance tasks, set the FLOWSIC100 to Maintenance Mode. This can be done using an external maintenance switch (connected to digital input 1), using SOPAS ET or via the LC-Display option (→ p. 152, 4.4).

Switch the system from “Maintenance” back to “Measuring” after completing the work.

Maintenance intervals

The maintenance intervals are assessed according to the qualification test. The maintenance interval depends on the specific conditions at the plant, such as operation, gas composition, temperature and humidity, as well as the ambient conditions and therefore shorter maintenance intervals may be necessary if conditions are unfavorable.

The activities required and their completion must be documented by the operator in a Maintenance Manual.

Maintenance agreement

Regular maintenance activities can be carried out by the plant operator. These activities must be carried out by qualified persons (as described in Chapter 1) only. If desired, SICK Service or authorized Service support centers can carry out all maintenance work. SICK offers a range of economical maintenance and repair agreements. As part of these agreements, SICK assumes responsibility for all maintenance activities, repairs are carried out by specialists on site (as far as possible).

5.2

Maintaining the sender/receiver units

The sender/receiver units must be cleaned at regular intervals and inspected for signs of corrosion and damage. To do so, remove the sender/receiver units from the flanges with tube.

**WARNING:**

When carrying out any work on the system, observe the relevant safety precautions as well as the safety instructions in § 1.3 (in particular § 1.3.3).

Required tools and aids:

- Spanner for Allen screws, SW 2 and 4
- Screwdriver
- Possibly a blind plug for flange with tube
- Brush, clean cloth, alcohol

5.2.1

Removing the sender/receiver units**WARNING:**

- ▶ Hot and/or aggressive gases can escape when removing and installing sender/receiver units → use suitable safety equipment!
- ▶ Shut the flange with tube with a blind flange after removing the sender/receiver unit.
- ▶ Carry out repair work only when hot parts have cooled sufficiently!
- ▶ Disconnect the cooled and purged sender/receiver units from the cooling air/purge air supply only after complete removal.

Procedure

- ▶ Loosen the cable connection on the sender/receiver unit by rotating the knurled nut on the plug counterclockwise and carefully removing the plug.
- ▶ Protect the loose cable ends from dirt or moisture. Seal the socket on the sender/receiver unit using the associated screw cap.

**NOTICE:**

Moist or corroded contacts will cause malfunctions.

- ▶ Loosen the screws on the sender/receiver unit flange.
- ▶ Carefully remove the sender/receiver unit and place it in a suitable location.
- ▶ If necessary (for example, if the duct is pressurized), seal the flange with tube using a blind plug (available as an option).

5.2.2 Cleaning the sender/receiver unit

Clean the outside of the sender/receiver unit after it has been removed. Inspect the probe tube and transducers for signs of corrosion, and replace them if necessary. Dust deposits and caked dust can generally be removed without disassembling the transducer.

**NOTICE:**

The transducer must be cleaned with extreme care. Do not damage the transducer diaphragm.



Depending on system conditions, the probe tube and transducers may initially require maintenance more frequently (approx. every 2 weeks, or less if necessary). If contamination is limited, the cleaning intervals can be gradually extended to max. 6 months.

Reinstall the sender/receiver unit after completing the work.

The work required for possible replacement of parts (probe tube, transducers) is listed in the Service Manual.

5.3 **Maintaining the cooling air supply of the internally cooled types M-AC and H-AC**

Maintenance tasks are:

- Inspecting the entire cooling air supply
- Cleaning the filter housing
- Replacing the filter element, if necessary

The dust load and wear on the filter element depend on the degree of contamination of the intake ambient air. For this reason, specific intervals for carrying out these activities cannot be given. We recommend inspecting the cooling air supply at short intervals (approx. 2 weeks) and then optimizing maintenance intervals over a longer period of operation.

**NOTICE:**

- Irregular or insufficient maintenance of the cooling air supply can cause it to fail and thus severely damage the sender/receiver unit!
- The cooling air supply must be guaranteed while the sender/receiver units are installed. Disassemble the sender/receiver unit before exchanging a damaged cooling air hose (→ p. 163, 5.4).

5.3.1

Inspection

- ▶ Check the running noise of the blower at regular intervals; increases in the noise level can indicate a blower failure.
- ▶ Check hoses are secure and free of damage.
- ▶ Check the filter element for contamination.

The filter element must be exchanged when:

- High contamination is visible (deposits on the filter surface)
- Cooling air flow is reduced considerably compared to operation with a new filter element.



The cooling air supply need not be switched off to clean the filter housing or replace the filter element, in other words, the sender/receiver unit can remain on the duct.

5.3.2

Control unit with integrated cooling air supply**Cleaning or replacing the filter element**

- ▶ Open the door of the connection unit with the appropriate key.
- ▶ Open the strap retainer on filter outlet (1) and pull the filter off connection piece (2).
- ▶ Remove the filter housing.
- ▶ Rotate the cover of the filter housing cover in the direction of the arrow “OPEN” and remove the cover.
- ▶ Remove the filter element and exchange with new insert.
- ▶ Clean the inside of the filter housing and filter housing cover with a cloth and brush.

**NOTICE:**

Only use a cloth soaked in water to wet-clean the parts and then dry the parts thoroughly.

- ▶ Insert the new filter element
- ▶ Mount the filter housing cover and rotate against the direction of the arrow until it audibly locks into position.
- ▶ Install the filter housing back in the connection unit.



Spare part: Filter element C1140, Part No. 7047560

Fig. 135

Changing the filter element for the control unit with cooling air supply

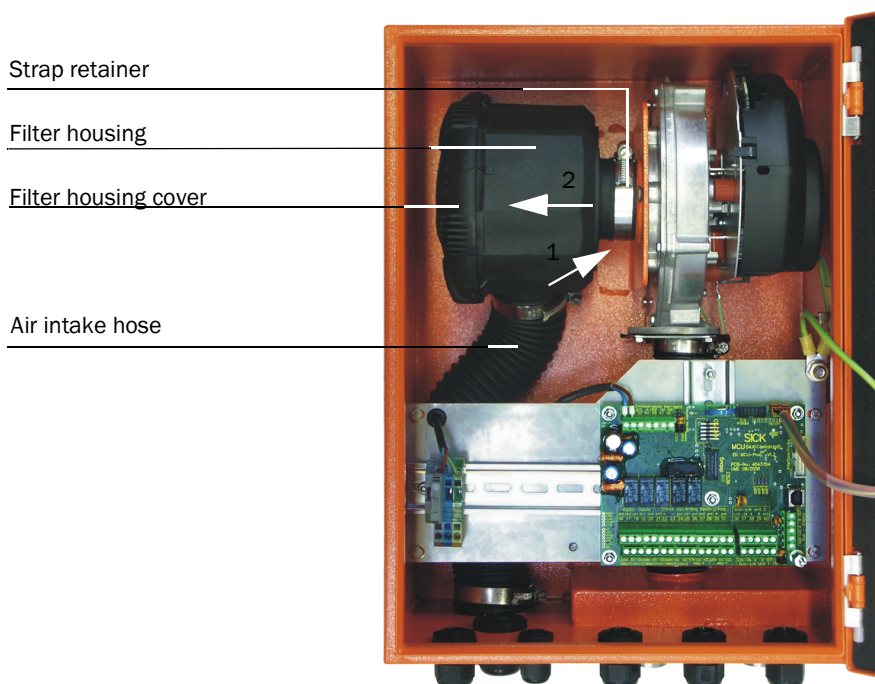

5.4

Maintaining the external purge air unit accessory

The following work is only necessary when purged sender/receiver units (types FLSE100-PM, PH, PHS) are used. Maintenance activities are:

- ▶ Inspecting the purge air supply
- ▶ Cleaning the filter housing
- ▶ Replacing the filter element

The dust load and wear on the filter element depend on the degree of contamination of the intake ambient air. For this reason, specific intervals for carrying out these activities cannot be given. We recommend inspecting the purge air unit after start-up at short intervals (1 to 2 weeks) after start-up and then optimizing maintenance intervals over a longer period of operation.

The filter element must be exchanged when:

- High contamination is visible (deposits on the filter surface)
- Purge air flow is reduced considerably compared to operation with a new filter element.

**NOTICE:**

- Irregular or insufficient maintenance of the purge air supply can cause it to fail and thus severely damage the transducers!
- The purge air unit must be maintained at the latest when the low-pressure sensor on the filter outlet is triggered.
- Purge air supply must be guaranteed while the sender/receiver units are installed. Remove the sender/receiver units from the duct before replacing any damaged purge air hoses.



The purge air unit does not have to be switched off to clean the filter housing or replace the filter element, i.e. sender/receiver units can remain on the duct.

5.4.1

Inspection

- ▶ Check the running noise of the blower at regular intervals; increases in the noise level can indicate a blower failure.
- ▶ Check hoses are secure and free of damage.
- ▶ Check the filter element for contamination. If the filter element is excessively contaminated, remove it, clean the filter housing, and fit a new filter element.

5.4.2

Replacing the filter element

- ▶ Have a new filter element (2) available.
- ▶ Loosen the hose clamp (6) on the purge air hose (7) and remove the hose and secure the hose at a clean location.

**NOTICE:**

Place the end of the hose in a safe place so that impurities cannot be sucked in (risk of severe damage to the blower). Unfiltered air enters the sender/receiver unit during this time.

- ▶ Remove any dust from the outside of filter housing (1).
- ▶ Press the two quick-release locks (4) on filter housing cover (3) to remove it.
- ▶ Remove filter element (2) by twisting it counterclockwise.
- ▶ Clean the inside of the filter housing and filter housing cover with a cloth and brush.

**NOTICE:**

Only use a cloth soaked in water to wet-clean the parts and then dry the parts thoroughly.

- ▶ Insert the new filter element by twisting it clockwise.
- ▶ Mount the filter housing cover and ensure it is aligned correctly with the housing, and snap the quick-release locks into position.
- ▶ Connect the purge air hose to the filter outlet again using the hose clamp.

Fig. 136

Replacing the filter element

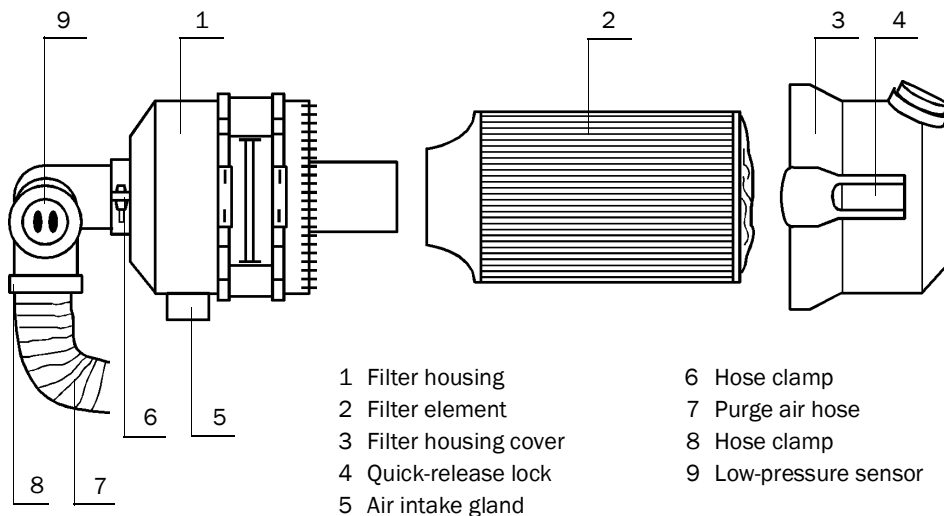

Spare part: Filter element Micro-Top element C11 100, Part No. 5306091

FLWSIC100

6 Specification

Technical Data
Dimensions, Part No.

6.1 **Technical Data**

Measured value recording										
Measured variables	Gas flow rate, volume flow act., volume flow std., gas temperature, sound velocity									
Measuring range	Min. limit -40 to 0 m/s, max. limit from 0 to +40 m/s; continuously variable									
Accuracy of emission measurement ¹⁾	±0.1 m/s									
Reproducibility of process measurement, standard sender/receiver units	±1% for v > 2 m/s; ±0.02 m/s for v < 2 m/s									
Damping time	1 ... 300 s; freely selectable									
Displays										
LC-Display	For measured variables, warning and malfunction messages									
LED	Power supply, malfunction, maintenance request									
Installation										
FLSE100	M	H	PR	SA	SD	MAC	HAC	PM	PH	PHS
Measuring path transducer-transducer [m] ²⁾	0.2 - 4 ³⁾	2 - 15 ⁴⁾	0.27 - 0.28	0.2 - 2	0.2 - 2	0.2 - 4	2 - 13	0.5 - 3	1 - 10	2 - 13
Internal duct diameter [m] ⁵⁾	0.15 - 3.4	1.4 - 13	> 0.40	0.15 - 1.7	0.15 - 1.7	0.15 - 3.4	1.4 - 11.3	0.35 - 2.5	0.7 - 8.7	1.4 - 11.3
Gas temperature [°C]	-40 ... +260			-40 ... +150		-40 ... +450		-40 ... +450		
Installation angle (recommended) [°] ⁶⁾	45 ... 60		45	45 ... 60				45 ... 60		
Internal duct pressure [bar]	± 0.1							±0.03 ⁷⁾ ; ±0.1 ⁸⁾		
Max. dust concentration [g/m ³ std.] ⁹⁾	1	100 ¹⁰⁾	1				100 ¹⁰⁾	100		
Cable length between junction box and MCU [m]	Max. 1000									
Output signals										
Analog output	0/2/4 ... 22 mA, max. load 750 Ω; resolution 12 bits; further analog outputs with I/O modules (option)									
Relay outputs	5 potential-free outputs (changeover contacts) for status signals operation/malfunction, limit value, warning, maintenance, check cycle; load 48 V, 1 A (low voltage protection); Further relay outputs with I/O modules (option)									
Input signals										
Analog inputs	2 inputs 0 ... 5/10 V or 0 ... 20 mA (without electric isolation); resolution 10 bits; further analog inputs with I/O modules (option)									
Digital inputs	4 potential-free contacts for connection of maintenance switch, activation of check cycle, separate zero point control, separate span test; Further digital inputs with I/O modules (option)									
Communication interfaces										
USB 1.1, RS232 (on terminals)	For measured value retrieval, configuration and firmware update via PC/laptop with SOPAS ET									
RS485	For connection of sender/receiver unit									
Interface module option	For communication with host PC, optionally for RS485, Profibus, USB, Ethernet									
Power supply										
Operating voltage	90 ... 250 V a.c., 50/60 Hz, 24 V d.c.									
Maximum power input	Approx. 40 W Types FLSE100-PM, PH, PHS, S, M, H, PR Approx. 75 W Types FLSE100-MAC, HAC									

Ambient conditions	
Temperature range ¹¹⁾	-40 ... +60 °C Sender/receiver units -40 ... +60 °C Control unit MCU-N -40 ... +45 °C Control unit MCU-P, cooling air supply in junction box ¹²⁾
Storage temperature	-40 ... +70 °C
Degree of protection	IP 65 sender/receiver units (electronic housing) IP 65 MCU-N IP 54 MCU-P
Dimensions, weight	
FLSE100	Nominal length (type specific) 200 / 260 / 350 / 550 / 750 mm; Weight (type specific) max. approx. 10.6 kg
MCU-N	Dimensions: 340 mm x 210 mm x 120 mm; enclosure made of steel plate, coated Weight: Approx. 5 kg
MCU-P, purge air supply in junction box	Dimensions: 440 mm x 300 mm x 220 mm; enclosure made of steel plate, coated Weight: Approx. 14 kg
Flange with tube	Nominal length 125 / 200 / 350 / 550 / 750 mm; Pitch diameter of mounting holes 75 / 100 / 170 mm (depends on FLSE100 type); Material St37, V4A (others on request), max. weight approx. 6 kg
Purge air unit accessory (with blower type 2BH1300)	
Components	Installation plate, air filter, purge air blower, Y distributor, low-pressure sensor
Operating voltage	200 ... 240 V / 345 ... 415 V at 50 Hz; 220 ... 275 V / 380 ... 480 V at 60 Hz
Rated current	D 2.6 A / Y 1.5 A
Motor rating	0.37 kW at 50 Hz; 0.45 kW at 60 Hz
Delivery rate	Max. 63 m ³ /h; 48 m ³ /h for counter-pressure 30 mbar
Ambient temperature	-20 ... +40 °C
Degree of protection	IP 54
Hose connections	Ø 40 mm
Dimensions, weight	550 mm x 550 mm x 270 mm; weight 14 kg

- 1): The accuracy of flow measurements depends on calibration, installation conditions, flow profile, and variation range of pressure and temperature parameters. Typical values for one-path measurement are 1 ... 5 %.
- 2): Maximum possible measuring path depends on dust content, gas temperature, and gas composition.
- 3): Maximum possible measuring path FLSE100-M HSHS (duct probe and transducer made of Hastelloy) is 2 m.
- 4): Maximum possible measuring path FLSE100-H HSHS (duct probe and transducer made of Hastelloy) is 5 m.
- 5): Minimum diameter for installation angle 45°, maximum diameter for installation angle 60°.
- 6): Use installation angle 60° for high dust contents.
- 7): With standard purge air unit.
- 8): Fitted with purge air blower 2BH1400 at overpressure > 0.03 bar (contact SICK).
- 9): Maximum possible dust concentration depends on the measuring path and gas temperature.
- 10): Only for dry and non-sticky dust.
- 11): Lower ambient temperatures for FLSE and MCU on request.
- 12): For MCU with integrated purge air blower, the ambient temperatures may not sink below -40 °C during operation and -20 °C during blower start-up operation.

6.2 Standard components

The standard components required for a complete measuring system depend on the mechanical design of the sender/receiver unit. The following Table shows the possible combinations and the quantities required:

Sender/receiver unit		Flange with tube ¹⁾	Connection cable		Junction box	Control unit		Purge air unit ²⁾
Type	Number		Master	Slave		MCU-N	MCU-P	
FLSE100-M, H	2	2	1	1	1	1	–	–
FLSE100-PR	1	1	–	1	– ³⁾	1	–	–
FLSE100-SA/SD	1 each	2	–	1	– ³⁾	1	–	–
FLSE100-M-AC, HAC	2	2	1	1	1	–	1	–
FLSE100-PM, PH, PHS	2	2	1	1	1	1	–	1

1):The flange with tube or connection must be suitable for the sender/receiver unit (see Flange with Tube Table)

2):Select the type depending on the internal duct pressure

3):Junction box optional for longer cable lengths

6.3 **Dimensions, Part No.**

All dimensions are in mm.

6.3.1 **Sender/receiver units**

Standard sender/receiver units

Fig. 137

FLSE100-M

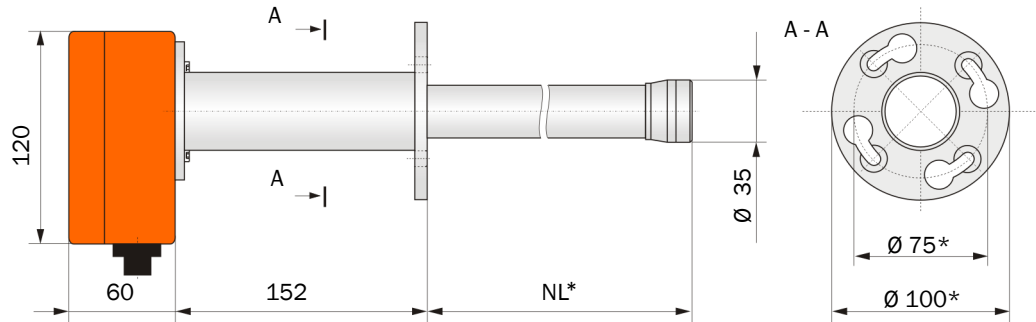

NL = 200 / 350 / 550**

*: Deliverable with pitch diameter 100 mm and flange diameter 125 mm on request

** : Other nominal lengths on request

Designation	Part No.
FLSE100-M 20SSTI sender/receiver unit	1042678
FLSE100-M 35SSTI sender/receiver unit	1042679
FLSE100-M 55SSTI sender/receiver unit	1042680
FLSE100-M 20TITI sender/receiver unit	1042681
FLSE100-M 35TITI sender/receiver unit	1042682
FLSE100-M 55TITI sender/receiver unit	1042683
FLSE100-M 20HSHS sender/receiver unit	1042684
FLSE100-M 35HSHS sender/receiver unit	1042685

Fig. 138

FLSE100-H

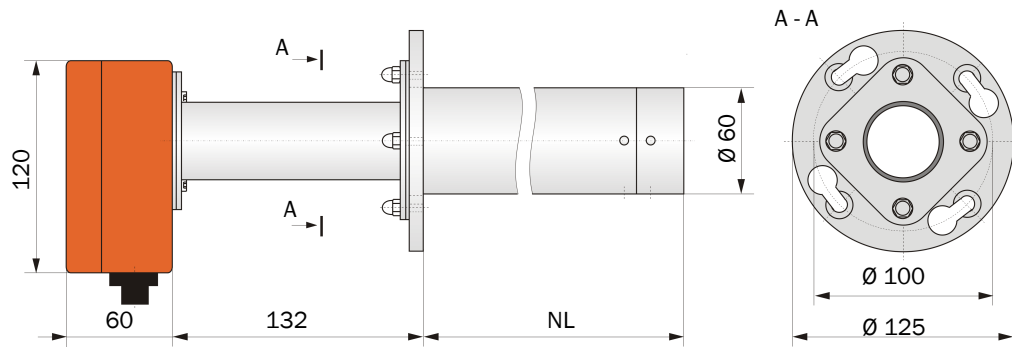

NL = 200 / 350 / 550 / 750 *

* Other nominal lengths on request

Designation	Part No.
FLSE100-H 20SSTI sender/receiver unit	1042687
FLSE100-H 35SSTI sender/receiver unit	1042688
FLSE100-H 55SSTI sender/receiver unit	1042689
FLSE100-H 75SSTI sender/receiver unit	1042690
FLSE100-H 20TITI sender/receiver unit	1042691
FLSE100-H 35TITI sender/receiver unit	1042692
FLSE100-H 55TITI sender/receiver unit	1042693
FLSE100-H 75TITI sender/receiver unit	1042694
FLSE100-H 35HSHS sender/receiver unit	1042695
FLSE100-H 55HSHS sender/receiver unit	1042696

Fig. 139

FLSE100-PR

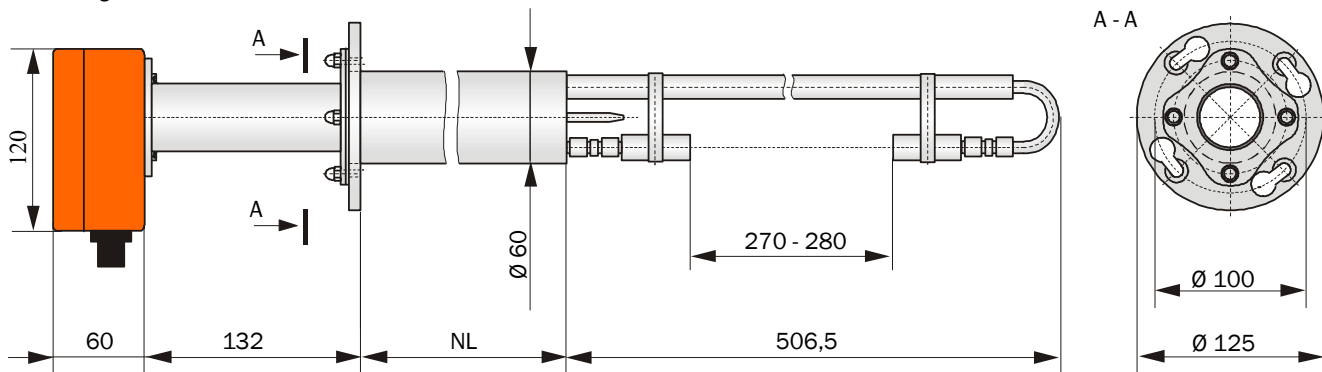

NL = 350 / 550 / 750 *

* Other nominal lengths on request

Designation	Part No.
FLSE100-PR 35SSTI sender/receiver unit	1042698
FLSE100-PR 55SSTI sender/receiver unit	1042699
FLSE100-PR 75SSTI sender/receiver unit	1042700
FLSE100-PR 35TITI sender/receiver unit	1042701
FLSE100-PR 55TITI sender/receiver unit	1042702
FLSE100-PR 75TITI sender/receiver unit	1042703

Fig. 140

FLSE100-SA

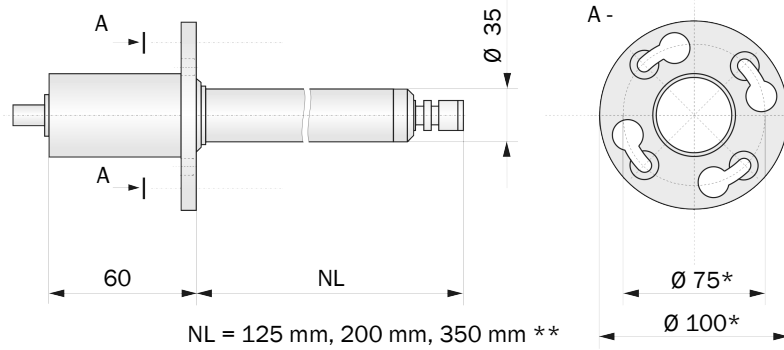

Designation	Part No.
FLSE100-SA 12SSTI sender/receiver unit	1043745
FLSE100-SA 20SSTI sender/receiver unit	1043749
FLSE100-SA 35SSTI sender/receiver unit	1043746

Fig. 141

FLSE100-SD

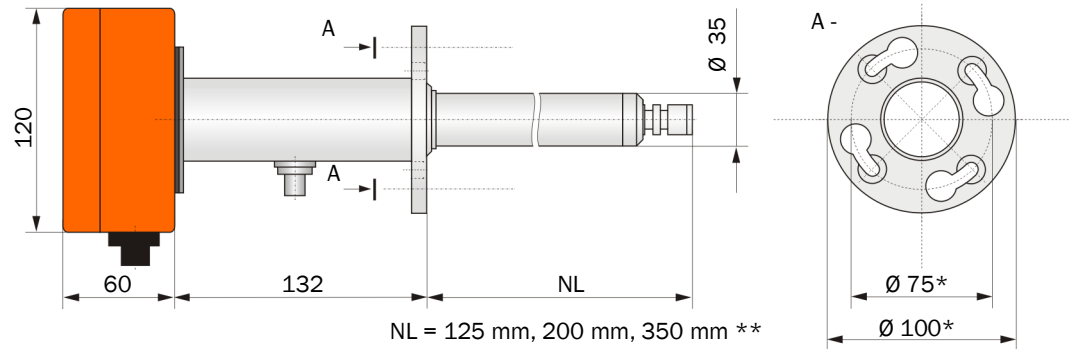

Designation	Part No.
FLSE100-SD 12SSTI sender/receiver unit	1043742
FLSE100-SD 20SSTI sender/receiver unit	1043747
FLSE100-SD 35SSTI sender/receiver unit	1043743

*: Deliverable with pitch diameter 100 mm and flange diameter 125 mm on request

** : Other nominal lengths on request

Sender/receiver units with internal cooling

Fig. 142

FLSE100-MAC

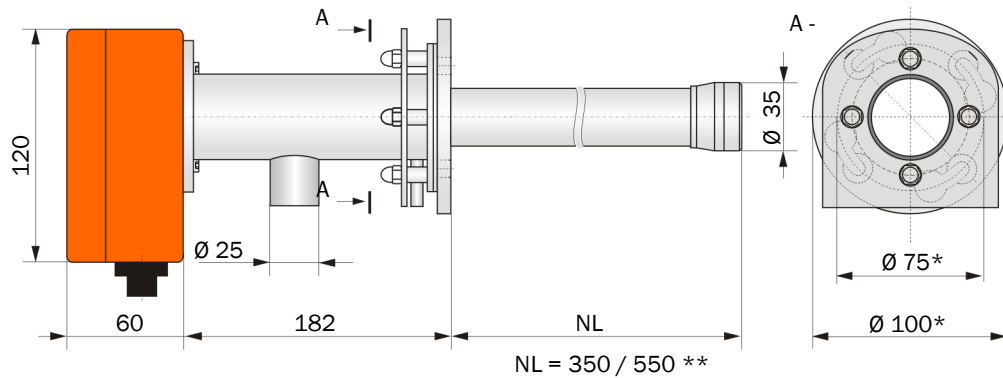

Designation	Part No.
FLSE100-MAC 35SSTI sender/receiver unit	1042771
FLSE100-MAC 55SSTI sender/receiver unit	1042772
FLSE100-MAC 35TITI sender/receiver unit	1042773
FLSE100-MAC 55TITI sender/receiver unit	1042774

Fig. 143

FLSE100-HAC

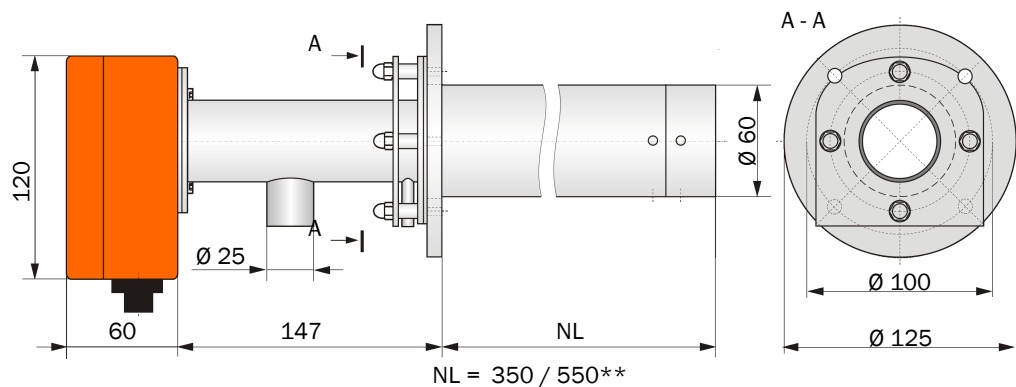

Designation	Part No.
FLSE100-HAC 35SSTI sender/receiver unit	1042775
FLSE100-HAC 55SSTI sender/receiver unit	1042776
FLSE100-HAC 35TITI sender/receiver unit	1042777
FLSE100-HAC 55TITI sender/receiver unit	1042778

*: Deliverable with pitch diameter 100 mm and flange diameter 125 mm on request

** : Other nominal lengths on request

Subject to change without notice

Purged sender/receiver units

Fig. 144 FLSE100-PM, FLSE100-PH, FLSE100-PHS

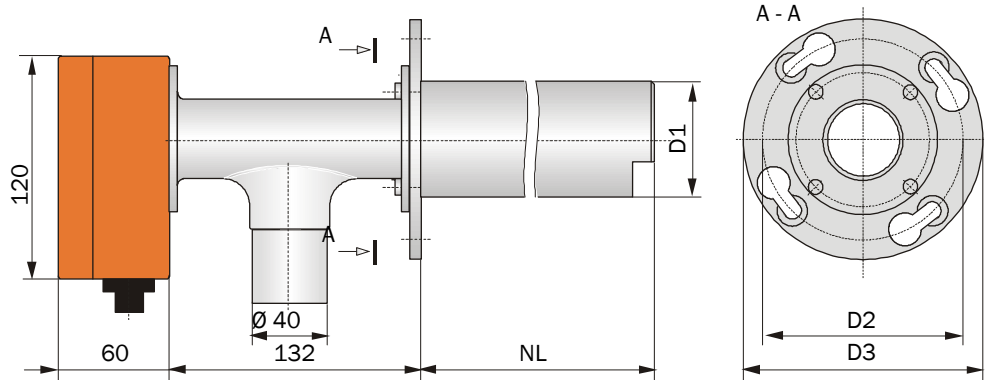

Type of sender/receiver unit	NL*	D1	D2	D3
FLSE100-PM, FLSE100-PH	200, 350, 550, 750	60,3	100	125
FLSE100-PHS	350, 550, 750	76	170	210

Designation	Part No.
FLSE100-PM 20SSTI sender/receiver unit	1042674
FLSE100-PM 35SSTI sender/receiver unit	1042675
FLSE100-PM 55SSTI sender/receiver unit	1042676
FLSE100-PM 75SSTI sender/receiver unit	1042677
FLSE100-PH 20SSTI sender/receiver unit	1042659
FLSE100-PH 35SSTI sender/receiver unit	1042660
FLSE100-PH 55SSTI sender/receiver unit	1042661
FLSE100-PH 75SSTI sender/receiver unit	1042662
FLSE100-PH 20TITI sender/receiver unit	1042663
FLSE100-PH 35TITI sender/receiver unit	1042664
FLSE100-PH 55TITI sender/receiver unit	1042665
FLSE100-PH 75TITI sender/receiver unit	1042666
FLSE100-PHS 35SSTI sender/receiver unit	1042667
FLSE100-PHS 55SSTI sender/receiver unit	1042668
FLSE100-PHS 75SSTI sender/receiver unit	1042669

* Other nominal lengths on request

6.3.2 Flange with tube

Fig. 145 Flange with tube

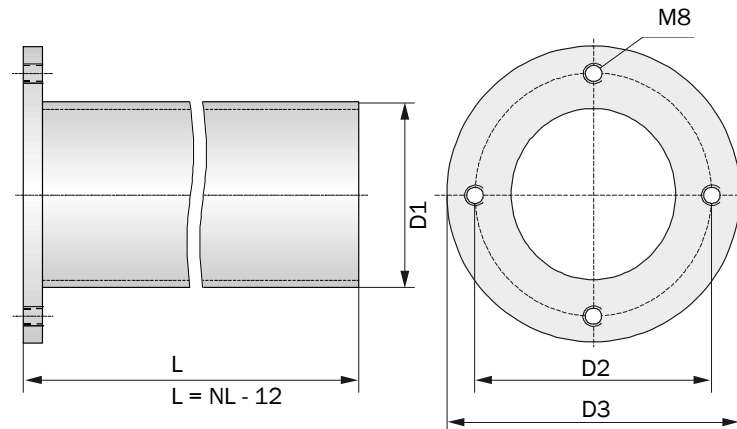

D1	D2	D3	NL	Type FLSE100
48,3	75	100	125	SA, SD
			200, 350	SA, SD, M
			350, 550	M, MAC
76,1	100	122	200	H, PM, PH
			350	H, HAC, PR, PM, PH
			550	H, HAC, PR, PM, PH
			750	H, PR, PM, PH
114,3	170	210	350, 550, 750	PHS

Designation	Part No.	For type FLSE100
Flange with tube D70ST200 Material St37, nominal length 200 mm	7042106	H, PM, PH
Flange with tube D70ST350 Material St37, nominal length 350 mm	7042109	H, PR, PM, PH
Flange with tube D70ST550 Material St37, nominal length 550 mm	7042110	
Flange with tube D70ST750 Material St37, nominal length 750 mm	7042247	
Flange with tube D70SS200 Material VA, nominal length 200 mm	7042111	H, PM, PH
Flange with tube D70SS350 Material VA, nominal length 350 mm	7042112	H, PR, PM, PH
Flange with tube D70SS550 Material VA, nominal length 550 mm	7042113	
Flange with tube D70SS750 Material VA, nominal length 750 mm	7042249	

Subject to change without notice

Designation	Part No.	For type FLSE100
Flange with tube D114ST350 Material St37, nominal length 350 mm	2033106	PHS
Flange with tube D114ST550 Material St37, nominal length 550 mm	7042356	
Flange with tube D114ST750 Material St37, nominal length 750 mm	7041949	
Flange with tube D50ST125 Material St37, nominal length 125 mm	7042279	SA, SD
Flange with tube D50ST200 Material St37, nominal length 200 mm	7042280	M, SA, SD
Flange with tube D50ST350 Material St37, nominal length 350 mm	7042281	
Flange with tube D50ST550 Material St37, nominal length 550 mm	7042282	M
Flange with tube D50SS125 Material St37, nominal length 125 mm	7042284	SA, SD
Flange with tube D50SS200 Material VA, nominal length 200 mm	7042285	M, SA, SD
Flange with tube D50SS350 Material VA, nominal length 350 mm	7042286	
Flange with tube D50S550 Material VA, nominal length 550 mm	7042287	M

6.3.3 MCU control unit

Control unit MCU-N (without integrated cooling air supply)

Fig. 146 Control unit MCU-N (with display module option)

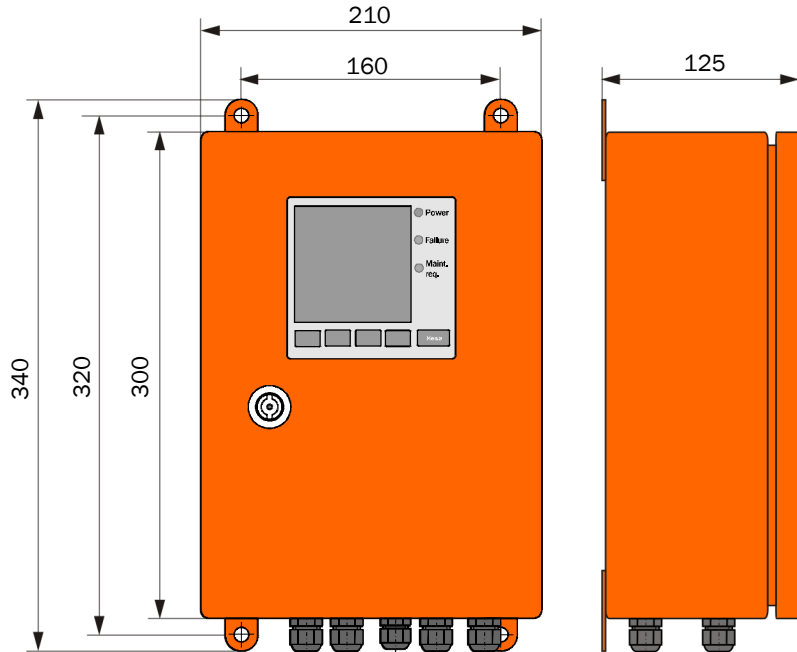

Designation	Part No.
MCU-NWONN00000NN control unit in wall housing (orange), Supply voltage 90 ... 250 V AC, without display	1040667
MCU-NWODN00000NN control unit in wall housing (orange), Supply voltage 90 ... 250 V AC, with display	1040675
MCU-N2ONN00000NN control unit in wall housing (orange), Supply voltage 24 V DC, without display	1040669
MCU-N2ODN00000NN control unit in wall housing (orange), Supply voltage 24 V DC, with display	1040677

Options

Designation	Part No.
Analog input module (AI)	2034656
Analog output module (AO)	2034657
Digital output module: 2 channels (changeover contact)	2034659
Slot rail for fitting one each AI, AO, DO module	6033578
Profibus DP interface module with MCU connection cable	2048920
Ethernet interface module with MCU connection cable	2055719
Ethernet interface module, 3-fold, with MCU connection cable	2072693
Modbus RS485 interface module with MCU connection cable	2048958
Modbus TCP interface module with MCU connection cable	2059546

Control unit MCU-P (with integrated cooling air supply)

Fig. 147 MCU-P (shown with display module option)

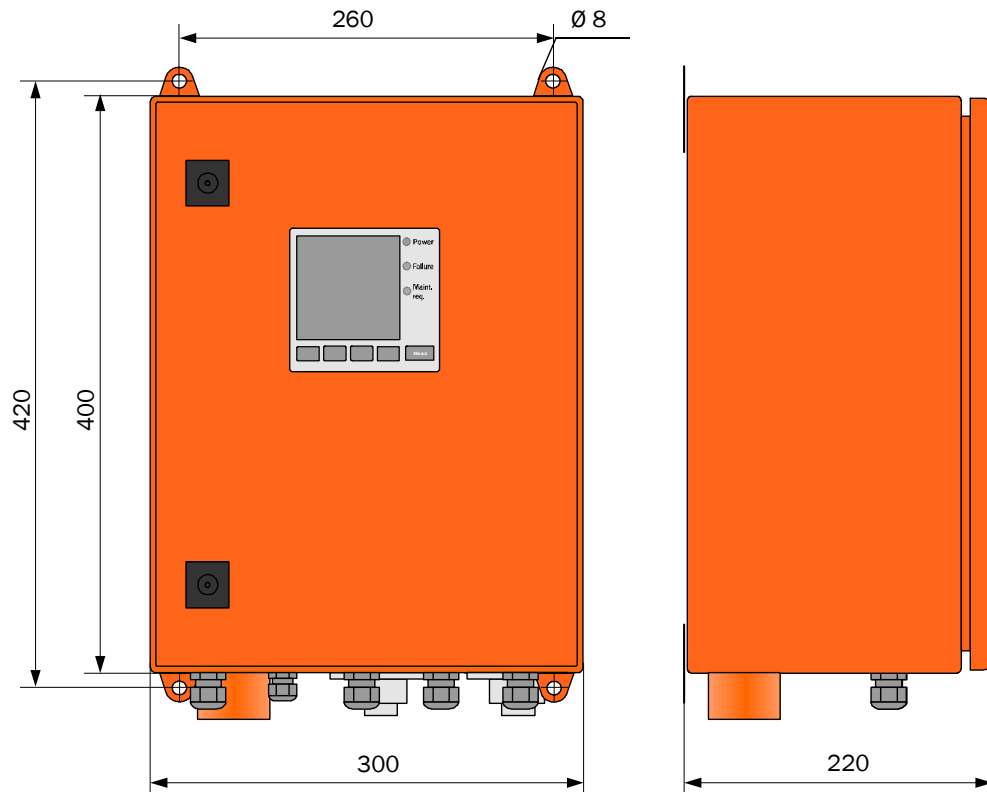

Designation	Part No.
MCU-PWONN00000NN control unit in wall housing (orange), Supply voltage 90 ... 250 V AC, with purge air unit, without display	1040668
MCU-PWODN00000NN control unit in wall housing (orange), Supply voltage 90 ... 259 V AC, with purge air unit, with display	1040676
MCU-P2ONN00000NN control unit in wall housing (orange), Supply voltage 24 V DC, with purge air unit, without display	1040670
MCU-P2ODN00000NN control unit in wall housing (orange), Supply voltage 24 V DC, with purge air unit, with display	1040678

Options

Designation	Part No.
Analog input module (AI)	2034656
Analog output module (AO)	2034657
Digital output module: 2 channels (changeover contact)	2034659
Slot rail for fitting one each AI, AO, DO module	6033578
Profibus DP interface module with MCU connection cable	2048920
Ethernet interface module with MCU connection cable	2055719
Ethernet interface module, 3-fold, with MCU connection cable	2072693
Modbus RS485 interface module with MCU connection cable	2048958
Modbus TCP interface module with MCU connection cable	2059546
Emergency air supply set for device types M-AC and H-AC	2051484
Cooling air control for device types FL100 M-AC and H-AC	2050814
Ethernet service interface module with MCU connection cable	2069667

6.3.4 Cooling air supply in junction box for FLOWSIC100 M-AC + H-AC

Fig. 148 Cooling air supply in junction box

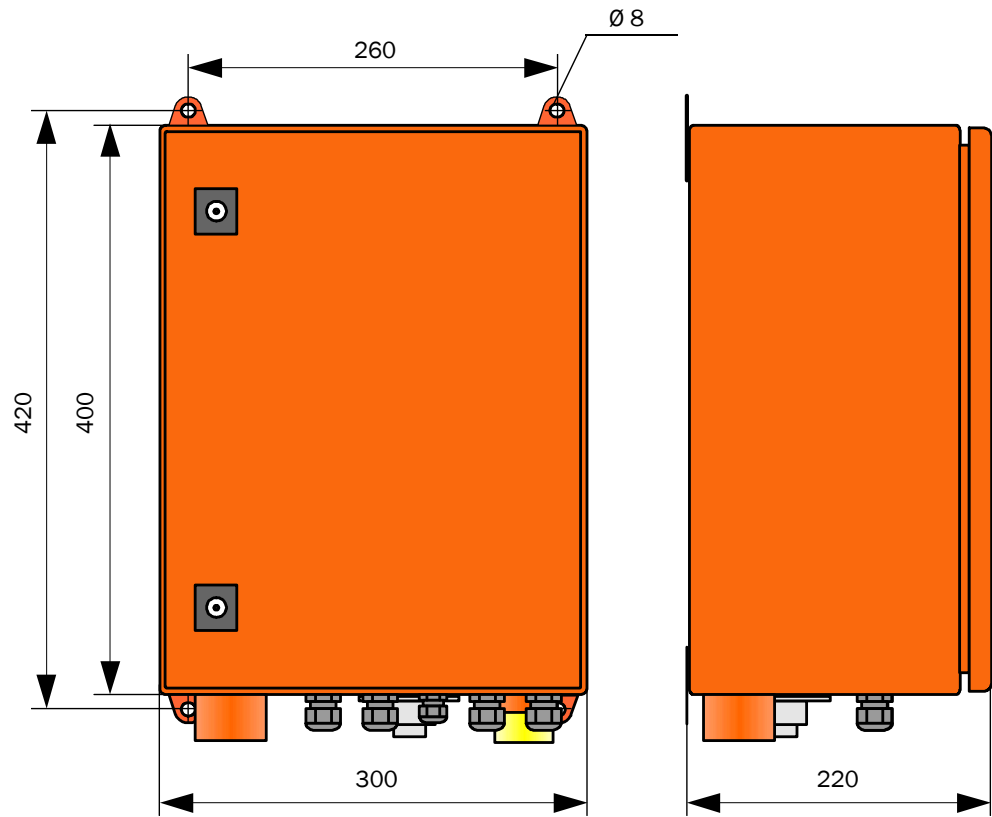

Designation	Part No.
Cooling air unit in junction box SLV-AK 230 V	2070816
Cooling air unit in junction box SLV-AK 24 V	2070817
Cooling air hose DN 25, length 3 m	7047535
Cooling air hose DN 25, length 10 m	7047536
Cooling air reducer (set) for FLOWSIC100 MAC, HAC	2057620

6.3.5 Junction box for connection cable

Fig. 149 Junction box for connection cable

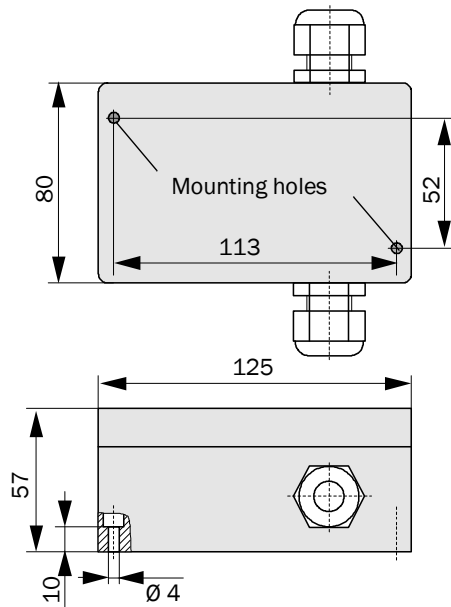

Designation	Part No.
Junction box for connection cable	2046418

Designation	Part No.
Connection cable Master 7-leads, length 5 m	2043678
Connection cable Master 7-leads, length 10 m	2043679
Connection cable Slave 5-leads, length 5 m	7042017
Connection cable Slave 5-leads, length 10 m	7042018
Connection cable Slave 5-leads, length 50 m	7042019
MCU connection cable, 5m, prefabricated	2055431
MCU connection cable, 10m, prefabricated	2055432
MCU connection cable LiYCY 2x2x0.5, sold by the meter, sold by the meter, not prefabricated	6030855
Fastening kit, 2D4-1.4571/PA, material 1.4571, plastic dowel	2031890

Purge air unit

Fig. 150 Standard purge air unit SLV1

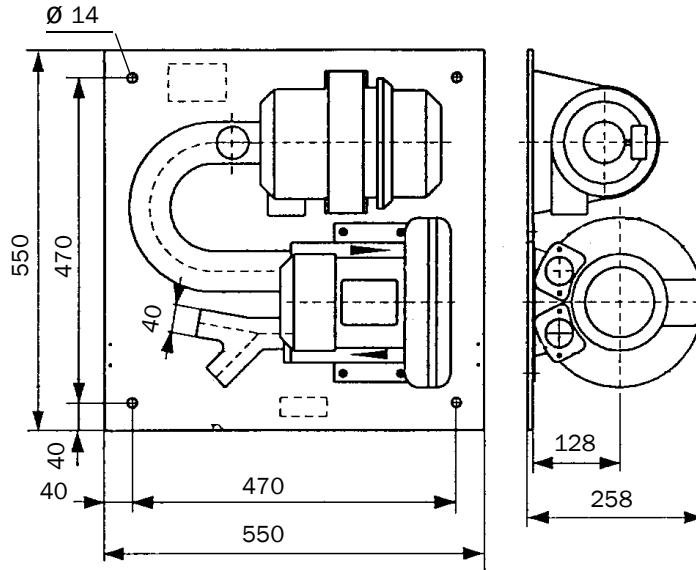
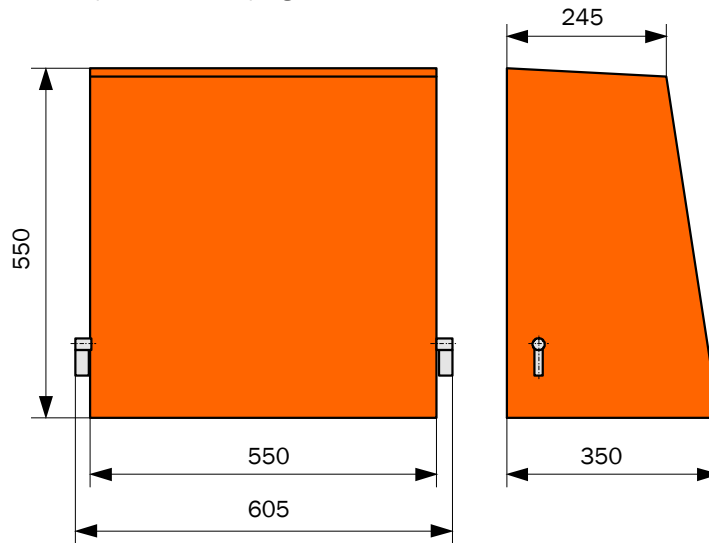

Fig. 151 Weatherproof cover for purge air unit



Designation	Part No.
Purge air unit with 2BH13 blower and purge air hose, length 5 m	1012424
Purge air unit with 2BH13 blower and purge air hose, length 10 m	1012409
Purge air unit with 2BH14 blower and purge air hose, length 10 m	1013461
Purge air reducer (set) to restrict the purge air flow	7042093
Designation	Part No.
Weatherproof cover for external blower unit	5306108

6.3.6

Miscellaneous

Designation	Part No.
Impact protector for transducer (for FLSE100-PM, PH, H)	2035283
Impact protector for transducer (for FLSE100-PHS)	7041980
Impact protector for transducer (for FLSE100-HAC)	2073079
Purge air reducer set	7042093
Hook spanner (for FLSE100-H)	7042115
Adjustment device	1700462
DME 2000 distance sensor	1010578
Retrofit: Damping set K75/K100	2042503
Assembly/damping set K100 for FLOWSIC100 H, H-AC	2056565
Assembly/damping set K75 for FLOWSIC100 M, M-AC	2056564
Weatherproof cover FLSE100	2064336

6.3.7 **Control unit, MCU 19"**

Fig. 152 Control unit, MCU in 19" slot (shown with display module option)

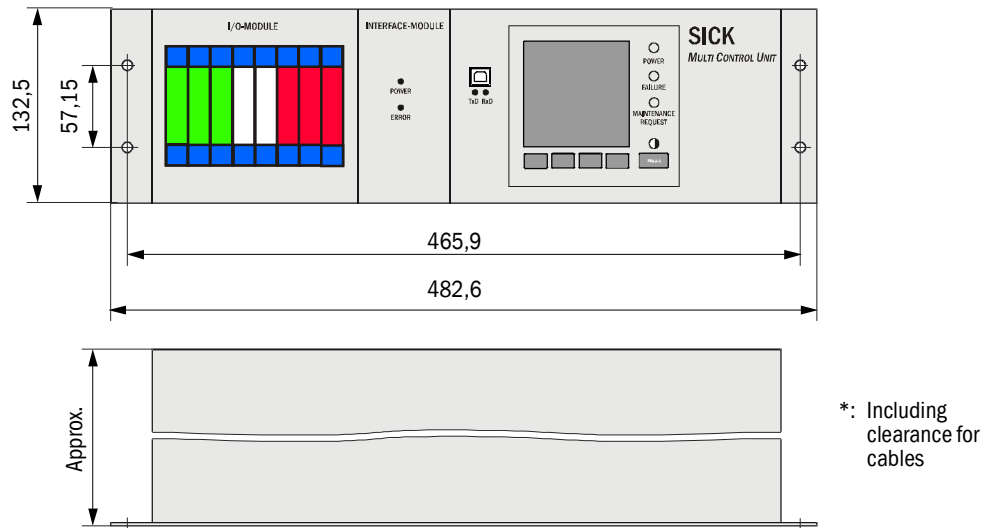

Designation	Part No.
Control unit, MCU-NWPD in 19" housing	1046117
Control unit, MCU-NWTD in 19" housing	1046288
Control unit, MCU-N2RD in 19" housing	1046116

Options for MCU control unit in 19" slot

Designation	Part No.
Analog input module (AI)	2034656
Analog output module (AO)	2034657
Digital output module: 2 channels (changeover contact)	2034659
Digital output module: 4 channels (make-contact)	2034661
I/O module carrier, 19" (for installing up to 4 AI/AO modules and 4 DI/DO modules)	2050589
Interface module 19" Profibus DP with connection cable	2049334
Interface module 19" Ethernet with connection cable	2048377
Interface module 19" Modbus RS485 with connection cable	2050674

6.3.8 **Consumable parts for 2-years operation**

6.3.9 **Control unit MCU with integrated purge air supply**

Designation	Number	Part No.
Filter element C1140	4	7047560

6.3.10 **External purge air unit accessory**

Designation	Number	Part No.
Filter element Micro-Topelement C11 100	4	5306091

Subject to change without notice

Australia

Phone +61 (3) 9457 0600
1800 33 48 02 – tollfree
E-Mail sales@sick.com.au

Austria

Phone +43 (0) 2236 62288-0
E-Mail office@sick.at

Belgium/Luxembourg

Phone +32 (0) 2 466 55 66
E-Mail info@sick.be

Brazil

Phone +55 11 3215-4900
E-Mail comercial@sick.com.br

Canada

Phone +1 905.771.1444
E-Mail cs.canada@sick.com

Czech Republic

Phone +420 234 719 500
E-Mail sick@sick.cz

Chile

Phone +56 (2) 2274 7430
E-Mail chile@sick.com

China

Phone +86 20 2882 3600
E-Mail info.china@sick.net.cn

Denmark

Phone +45 45 82 64 00
E-Mail sick@sick.dk

Finland

Phone +358-9-25 15 800
E-Mail sick@sick.fi

France

Phone +33 1 64 62 35 00
E-Mail info@sick.fr

Germany

Phone +49 (0) 2 11 53 010
E-Mail info@sick.de

Greece

Phone +30 210 6825100
E-Mail office@sick.com.gr

Hong Kong

Phone +852 2153 6300
E-Mail ghk@sick.com.hk

Hungary

Phone +36 1 371 2680
E-Mail ertekesites@sick.hu

India

Phone +91-22-6119 8900
E-Mail info@sick-india.com

Israel

Phone +972 97110 11
E-Mail info@sick-sensors.com

Italy

Phone +39 02 27 43 41
E-Mail info@sick.it

Japan

Phone +81 3 5309 2112
E-Mail support@sick.jp

Malaysia

Phone +603-8080 7425
E-Mail enquiry.my@sick.com

Mexico

Phone +52 (472) 748 9451
E-Mail mexico@sick.com

Netherlands

Phone +31 (0) 30 229 25 44
E-Mail info@sick.nl

New Zealand

Phone +64 9 415 0459
0800 222 278 – tollfree
E-Mail sales@sick.co.nz

Norway

Phone +47 67 81 50 00
E-Mail sick@sick.no

Poland

Phone +48 22 539 41 00
E-Mail info@sick.pl

Romania

Phone +40 356-17 11 20
E-Mail office@sick.ro

Russia

Phone +7 495 283 09 90
E-Mail info@sick.ru

Singapore

Phone +65 6744 3732
E-Mail sales.gsg@sick.com

Slovakia

Phone +421 482 901 201
E-Mail mail@sick-sk.sk

Slovenia

Phone +386 591 78849
E-Mail office@sick.si

South Africa

Phone +27 10 060 0550
E-Mail info@sickautomation.co.za

South Korea

Phone +82 2 786 6321/4
E-Mail infokorea@sick.com

Spain

Phone +34 93 480 31 00
E-Mail info@sick.es

Sweden

Phone +46 10 110 10 00
E-Mail info@sick.se

Switzerland

Phone +41 41 619 29 39
E-Mail contact@sick.ch

Taiwan

Phone +886-2-2375-6288
E-Mail sales@sick.com.tw

Thailand

Phone +66 2 645 0009
E-Mail marcom.th@sick.com

Turkey

Phone +90 (216) 528 50 00
E-Mail info@sick.com.tr

United Arab Emirates

Phone +971 (0) 4 88 65 878
E-Mail contact@sick.ae

United Kingdom

Phone +44 (0)17278 31121
E-Mail info@sick.co.uk

USA

Phone +1 800.325.7425
E-Mail info@sick.com

Vietnam

Phone +65 6744 3732
E-Mail sales.gsg@sick.com

Detailed addresses and further locations at www.sick.com