

# Cleaning Set

for all TRANSIC100LP variants

Installation, Operation

**SICK**  
Sensor Intelligence.



---

**Described Product** Cleaning Set for TRANSIC100LP

**Manufacturer** SICK AG  
Erwin-Sick-Str. 1  
79183 Waldkirch  
Germany

**Legal Notice** This work is protected by copyright. The rights thereby established remain with SICK AG. Reproduction of this work or any parts of it is only allowed within the constraints of the statutory provisions of the Copyright Act. Any modification, abbreviation or translation of this work is prohibited without express written consent by SICK AG.

The brands named in this document are the property of their respective owners.

© SICK AG. All rights reserved.

**Original Document** This document is an original document from SICK AG.



---

## Contents

<b>1</b>	<b>Cleaning Set for TRANSIC100LP .....</b>	<b>4</b>
1.1	Main operating information.....	4
1.2	Intended use.....	5
1.3	Responsibility of user.....	5
1.4	Product description.....	5
1.5	Operation.....	6
1.6	Specifications.....	7
1.7	Shutting down.....	7

## 1 Cleaning Set for TRANSIC100LP

### 1.1 Main operating information



#### **DANGER**

##### **Risk of injury by laser radiation**

TRANSIC100LP is a protection class 1 laser product.

Proper handling and operation of TRANSIC100LP is eye-safe, because laser radiation is collimated and maintained inside the probe. Reflections of the laser radiation which could cause eye injuries could occur when tools with reflecting surfaces (e.g. tools) are directly placed into the probe of the switched-on TRANSIC100LP.

- ▶ Put the device out of operation before any maintenance.
  - ▶ When TRANSIC100LP is in operation: Do not use objects/tools with reflecting surfaces.
- 



#### **WARNING**

##### **Risk of burns when used in hot gases**

- ▶ Make sure that all parts that come into contact with gas have cooled down before working on the device.
- 



#### **DANGER**

##### **Health risk through contaminated measuring device**

It is possible that toxic residues remain on the measuring device after operation in acidic process gas

- ▶ Always wear the specified protective clothing
- 



#### **WARNING**

##### **Risk of fire through reaction with oxygen**

Small amounts of grease and dust could cause reactions with oxygen.

- ▶ Keep the cleaning set free from grease and dust.
- 



#### **WARNING**

##### **Hazard of reactions of oxygen with cleaning agents**

Cleaning agent residues could react with oxygen.

- ▶ Make sure to rinse the optical components thoroughly when using cleaning agents.
  - ▶ Make sure that the cleaning agents used will not cause the swelling of the seals. Cleaning agent residues in the seals can react with oxygen.
-

**CAUTION**

The cleaning agent and dissolved substances can represent a hazard for the environment

- ▶ Observe the respective valid regulations for the disposal of hazardous substances.

## 1.2 Intended use

The TRANSIC100LP cleaning set is intended only for cleaning the optical component of the TRANSIC100LP product family.

## 1.3 Responsibility of user

- ▶ Read the Operating Instructions before using the TRANSIC100LP cleaning set.
- ▶ Observe all safety information.
- ▶ If there is anything you do not understand: Please contact SICK Customer Service.

All operators of the TRANSIC100LP cleaning should be specifically trained on this device, knowledgeable of relevant regulations and able to assess potential hazards related to this operation.

## 1.4 Product description

### TRANSIC100LP cleaning set

The TRANSIC100LP cleaning set is a cleaning bottle for cleaning the optical components of the TRANSIC100LP measuring devices. The TRANSIC100LP cleaning set allows to improve the cleaning effect by mechanical movement on the optical surfaces.

The cleaning set consists of PE (LD polyethylene) and polycarbonate.

- ▶ Make sure that the cleaning agents are compatible with this material.

## 1.5 Operation

Cleaning the optical components of the TRANSIC100LP measuring devices

### Cleaning the TRANSIC100LP optical components with air

- 1 Removing the filter: See the TRANSIC100LP Operating Instructions.
- 2 Remove loose particles from the mirror with a jet of clean air (instrument air or better quality).

When the optics have not become clean: Clean the optics with the cleaning set:

### Cleaning the TRANSIC100LP optical components with the cleaning set

- 1 Fill a third of the bottle with a mixture of distilled water and soap.
- 2 Insert the TRANSIC100LP into the bottle. Make sure that the O-ring fits in the groove and seals the TRANSIC100LP against the bottle.
- 3 Let the cleaning liquid work in for a short time (maximum 15 minutes). An increased cleaning effect is achieved by shaking the bottle with the TRANSIC100LP.
- 4 Remove the TRANSIC100LP from the bottle after 15 minutes and dispose of the liquid. Observe the safety information in Section "[Main operating information](#)".
- 5 Fill a third of the bottle with distilled water and repeat point 2-4. This serves to remove cleaning liquid residues.
- 6 Dry the optical surfaces (lenses and mirror) with compressed air (instrument air or better quality) until no more residues can be seen on the optics.  
If the optics are then still contaminated, repeat point 2-5 with a solvent, such as ethanol or isopropanol.
- 7 Insert the filter again when the cleaned mirror surface is without stains, dirt or dust.

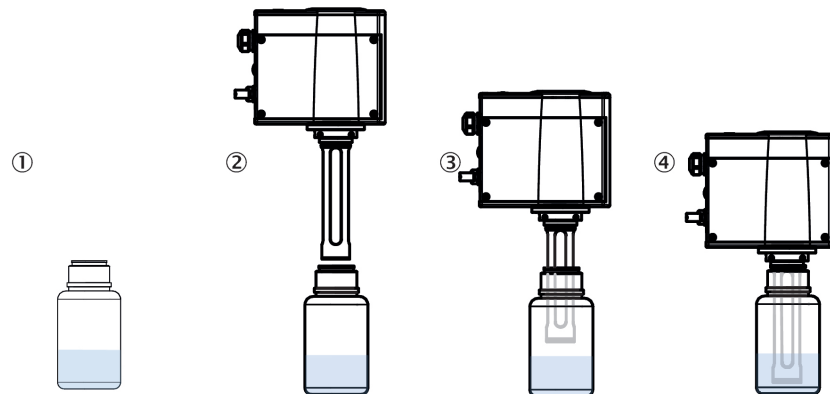

- ① Cleaning bottle with cleaning liquid
- ②,③ Inserting the measuring probe into the bottle
- ④ Measuring probe in cleaning set, sealed



### CAUTION

#### Risk of destruction of optical surfaces

Optical surfaces can be destroyed by mechanical cleaning (e.g. wiping, scratching).

- Do not clean surfaces mechanically.

## 1.6 Specifications

Material: Polycarbonate, LD polyethylene

## 1.7 Shutting down

---



### CAUTION

The cleaning agent and dissolved substances can represent a hazard for the environment

- ▶ Observe the respective valid regulations for the disposal of hazardous substances.
-

**Australia**

Phone +61 3 9457 0600  
1800 33 48 02 – tollfree  
E-Mail sales@sick.com.au

**Belgium/Luxembourg**

Phone +32 (0)2 466 55 66  
E-Mail info@sick.be

**Brasil**

Phone +55 11 3215-4900  
E-Mail marketing@sick.com.br

**Canada**

Phone +1 905 771 14 44  
E-Mail information@sick.com

**Česká republika**

Phone +420 2 57 91 18 50  
E-Mail sick@sick.cz

**China**

Phone +86 4000 121 000  
E-Mail info.china@sick.net.cn  
Phone +852-2153 6300  
E-Mail ghk@sick.com.hk

**Danmark**

Phone +45 45 82 64 00  
E-Mail sick@sick.dk

**Deutschland**

Phone +49 211 5301-301  
E-Mail info@sick.de

**España**

Phone +34 93 480 31 00  
E-Mail info@sick.es

**France**

Phone +33 1 64 62 35 00  
E-Mail info@sick.fr

**Great Britain**

Phone +44 (0)1727 831121  
E-Mail info@sick.co.uk

**India**

Phone +91-22-4033 8333  
E-Mail info@sick-india.com

**Israel**

Phone +972-4-6881000  
E-Mail info@sick-sensors.com

**Italia**

Phone +39 02 27 43 41  
E-Mail info@sick.it

**Japan**

Phone +81 (0)3 5309 2112  
E-Mail support@sick.jp

**Magyarország**

Phone +36 1 371 2680  
E-Mail office@sick.hu

**Nederland**

Phone +31 (0)30 229 25 44  
E-Mail info@sick.nl

**Norge**

Phone +47 67 81 50 00  
E-Mail sick@sick.no

**Österreich**

Phone +43 (0)22 36 62 28 8-0  
E-Mail office@sick.at

**Polska**

Phone +48 22 837 40 50  
E-Mail info@sick.pl

**România**

Phone +40 356 171 120  
E-Mail office@sick.ro

**Russia**

Phone +7-495-775-05-30  
E-Mail info@sick.ru

**Schweiz**

Phone +41 41 619 29 39  
E-Mail contact@sick.ch

**Singapore**

Phone +65 6744 3732  
E-Mail sales.gsg@sick.com

**Slovenija**

Phone +386 (0)1-47 69 990  
E-Mail office@sick.si

**South Africa**

Phone +27 11 472 3733  
E-Mail info@sickautomation.co.za

**South Korea**

Phone +82 2 786 6321/4  
E-Mail info@sickkorea.net

**Suomi**

Phone +358-9-25 15 800  
E-Mail sick@sick.fi

**Sverige**

Phone +46 10 110 10 00  
E-Mail info@sick.se

**Taiwan**

Phone +886 2 2375-6288  
E-Mail sales@sick.com.tw

**Türkiye**

Phone +90 (216) 528 50 00  
E-Mail info@sick.com.tr

**United Arab Emirates**

Phone +971 (0) 4 88 65 878  
E-Mail info@sick.ae

**USA/México**

Phone +1(952) 941-6780  
1 (800) 325-7425 – tollfree  
E-Mail info@sickusa.com

More representatives and agencies  
at [www.sick.com](http://www.sick.com)