

THREADED ENDS

| VALVE SIZE | DIMENSIONS, INCHES | | | | WEIGHT LBS |
|---------------|--------------------|-------|------|------|---------------|
| | A | B | C | D | |
| 1/4 | 5.00 | 7.56 | 2.56 | 5.00 | 11 |
| 3/8 | 5.00 | 7.56 | 2.56 | 5.00 | 11 |
| 1/2 | 5.00 | 7.56 | 2.56 | 5.00 | 11 |
| 3/4 | 5.00 | 9.37 | 2.62 | 6.87 | 20 |
| 1 | 5.00 | 9.37 | 2.62 | 6.87 | 20 |
| 1 1/4 | 7.50 | 16.75 | 3.87 | 9.37 | 68 |
| 1 1/2 | 7.50 | 16.75 | 3.87 | 9.37 | 68 |
| 2 | 7.50 | 16.75 | 3.87 | 9.37 | 68 |

FLANGED ENDS

| VALVE SIZE | FLANGE ANSI | DIMENSIONS, INCHES | | | | WEIGHT LBS |
|---------------|----------------|--------------------|-------|------|------|---------------|
| | | A ₁ ① | B | C | D | |
| 1/2 | 150# | 9.50 | 7.56 | 2.56 | 5.00 | 13 |
| | 300# | 9.75 | 7.56 | 2.56 | 5.00 | 16 |
| 3/4 | 150# | 9.50 | 9.37 | 2.62 | 6.87 | 24 |
| | 300# | 9.75 | 9.37 | 2.62 | 6.87 | 27 |
| 1 | 150# | 9.50 | 9.37 | 2.62 | 6.87 | 24 |
| | 300# | 9.75 | 9.37 | 2.62 | 6.87 | 27 |
| 1 1/4 | 150# | 13.00 | 16.75 | 3.87 | 9.37 | 74 |
| | 300# | 13.25 | 16.75 | 3.87 | 9.37 | 77 |
| 1 1/2 | 150# | 13.00 | 16.75 | 3.87 | 9.37 | 74 |
| | 300# | 13.25 | 16.75 | 3.87 | 9.37 | 81 |
| 2 | 150# | 13.00 | 16.75 | 3.87 | 9.37 | 78 |
| | 300# | 13.25 | 16.75 | 3.87 | 9.37 | 83 |

① NOT TO ANSI

TOLERANCES

BWE, FE, TRI-C & TUBE END DIM ARE $\pm 1/16"$
 ALL OTHER DIMENSIONS: $\pm 1/2"$

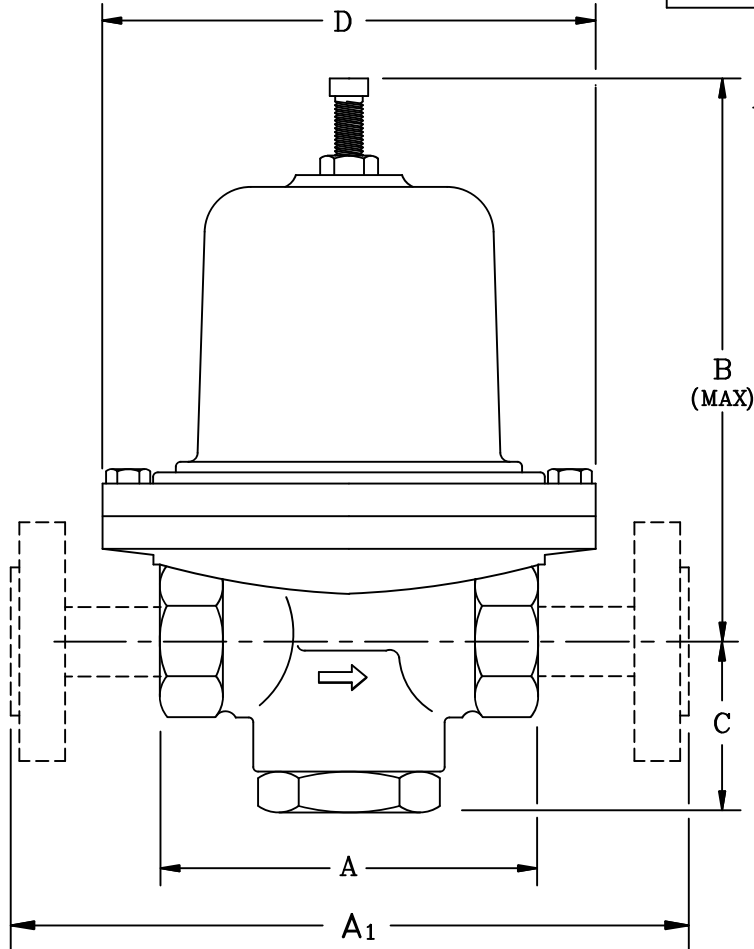

SPECIFICATION DATA

CUSTOMER _____
 ORDER No. _____ SERIAL No. _____
 TAG No. _____
 VALVE TYPE _____ QTY. _____
 BODY _____
 END CONN. _____
 INLET PRESS. _____ MAX. ΔP _____
 PRESS. RANGE _____ SET AT _____
 VALVE ACTION: RISE IN PRESSURE TO OPEN
 CLOSE
 VALVE SEAT _____ Cv _____
 MISC. _____
 CERTIFIED _____ DATE _____

RICHARDS INDUSTRIES
 CINCINNATI, OHIO
 U.S.A.

VALVE GROUP

FN: MK68G

**1/4-2" MARK 68 GLOBE STYLE
 PRESSURE REDUCING VALVE**

| | |
|------------|----------|
| DRAWN BY | DATE |
| JLW | 10/15/03 |
| CHECKED BY | DATE |
| | |

MK68G