

# Electrodes for pH/Redox Measurement *CeraLiquid P CPS 41/42/43*

pH/redox electrodes with ceramic diaphragm  
and liquid KCl electrolyte, also with integrated  
Pt 100 temperature sensor



## Areas of application

- The CeraLiquid P electrodes filled with liquid KCl are used in media with very low conductivities ( $\geq 0.1 \mu\text{S}/\text{cm}$ ), e.g.
    - ultrapure water
    - boiler feed water
  - They can be used wherever a high percentage of organic solvents or alcohols will not permit the application of a low-maintenance electrode with solid “Polytex” electrolyte.
- Important areas of application are:
- Food industry
  - Biotechnology
  - Laboratory measurements
  - Power plants.

## Benefits at a glance

- Liquid KCl electrolyte, enabling use even at lowest conductivities ( $\geq 0.1 \mu\text{S}/\text{cm}$ )
- Ceramic diaphragm with defined KCl flow
- Application under pressures of up to 8 bar with counterpressure
- Different pH membrane glasses, including versions for steam sterilisation (max. 130 °C)
- Three lengths: 120, 225 and 360 mm
- Also as combined pH electrode with integrated Pt 100 temperature sensor
  - Only one electrode mounting position and one connection cable required
  - Continuous and accurate temperature-compensated pH measurement
- TOP 68 connector ESA / ESS, water proof (IP 68)
- Improved B glass, sterilisable

Quality made by  
Endress+Hauser



ISO 9001

# Endress+Hauser

The Power of Know How



# Electrode construction and dimensions

left:  
Combined pH electrode  
CeraLiquid P CPS 41

right:  
Combined  
redox electrode  
CeraLiquid P CPS 42

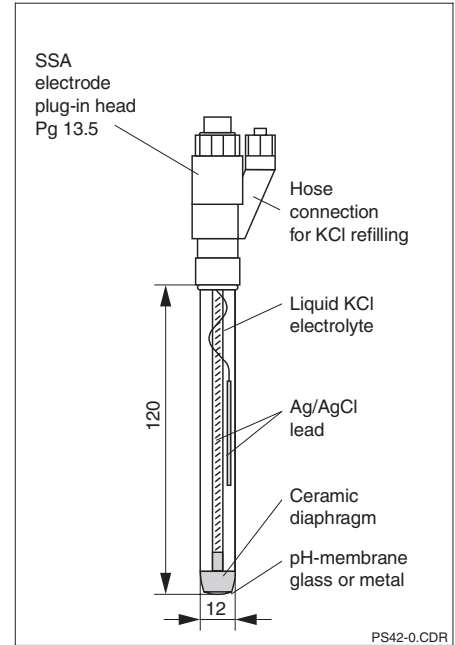
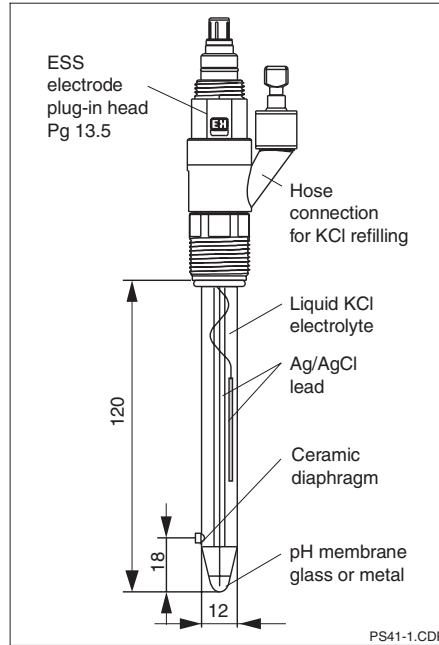

left:  
Combined pH electrode  
CeraLiquid P CPS 41  
with / without  
temperature sensor  
for Probit CPA 441

right:  
Probit CPA 441  
assembly

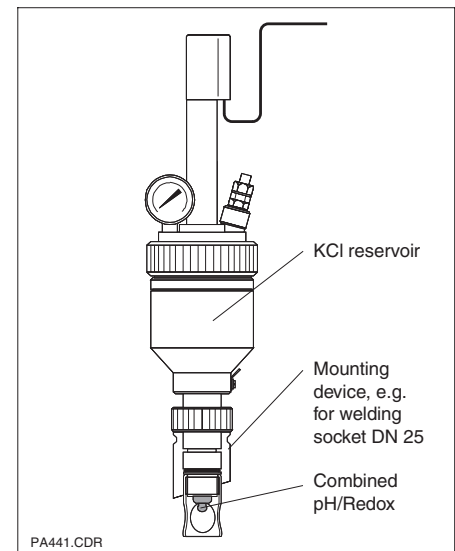
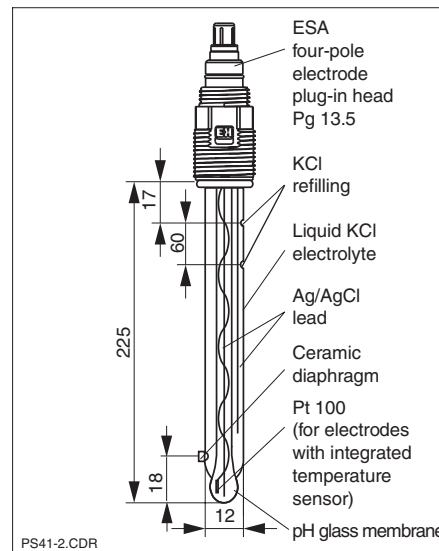

## pH electrode selection

When selecting the right pH electrode, the pH has to be considered as well as the temperature, the pressure and the conductivity of the medium to be measured. The temperature/pH range table is a guide for selecting a suitable pH membrane glass.

The conductivity of the medium to be measured determines the reference system to be selected. Finally select the correct electrode length and electrode connection head according to the order code.

## Type of head

### GSA

Standard plug-in head with coaxial connector for electrodes **without** temperature sensor

### HDA

Threaded plug-in head with Pg 13.5, TOP 68, 16 bar for electrodes **with** integrated temperature sensor.

### ESA

The new TOP 68 plug-in head for all pH and redox electrodes with or without integrated temperature sensor.

The ESA/ESS connection guarantees a stable connection between measuring cable and electrode even under hard operating conditions. The connector is robust, water proof (IP 68) and highly resistant against chemicals. It is suitable for Ex applications in zone 0 / 1G acc. to ATEX 100a. An adapter ring TOP 68 / SMEK is available for the connection of ESA electrodes to the SMEK cable (Order no. 51501123).

### ESS

Analog ESA, but with hose connection for liquid KCl.

# Temperature and pH ranges

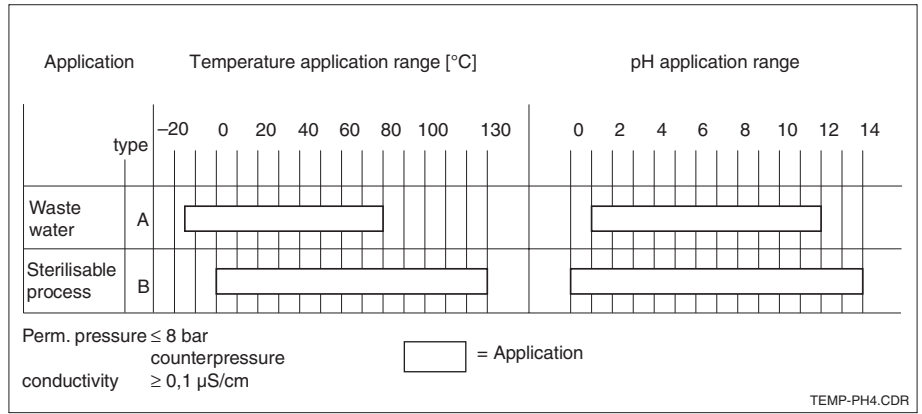

## Technical data

### General data

Manufacturer	Endress+Hauser
Product designation	CeraLiquid P CPS 41/42/43

### Electrical connection

Plug-in head	GSA head with Pg 13.5 for Probit CPA 441
	SSA head with hose connection for liquid KCl
	<i>only for combined pH with integrated Pt 100:</i>
	ESA head with Pg 13.5 for Probit CPA 441 (protection class IP 68), substitutes TSA connection
	ESS head PG 13.5, TOP 68 (protection class IP 68), substitutes TSS connection
	HDA head with Pg 13.5, TOP 68, 16 bar (triple safety overpressure according to TÜV-certifikate)
Shaft length	120 / 225 / 360 mm
Diameter	12 mm

### Reference system

Metal lead	Ag/AgCl
Electrolyte	liquid KCl 3 mol, AgCl-free
Pressure range	≤ 8 bar with counterpressure via separate KCl vessel
Diaphragm	Ceramic
Temperature range	-15 ... 130 °C
Minimum conductivity	≥ 5 µS/cm for 1 diaphragm, ≥ 0,1 µS/cm for 3 diaphragms
pH membrane glasses	type A, B
pH range	0 ... 14
Chain zero point	E <sub>0</sub> = 7,0
Redox measuring element	platinum ring

Subject to modifications.

## KCl flow

KCl consumption

above:  
KCl flow dependent on the media temperature

below:  
KCl flow dependent on the process pressure

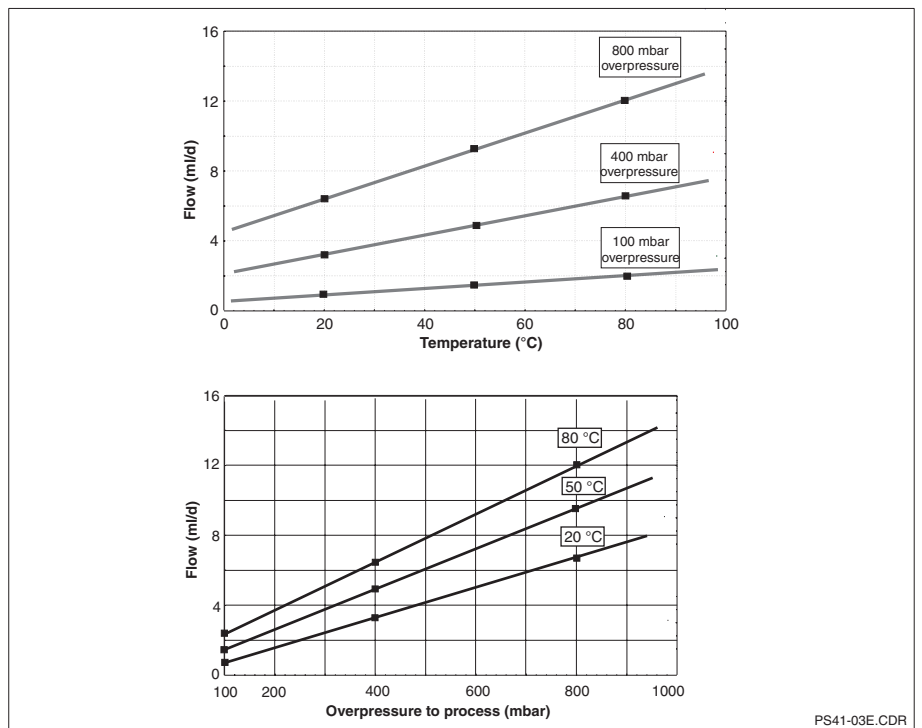

PS41-03E.CDR

# Product structure

pH electrodes CeraLiquid P CPS 41				
<p><b>Electrode type</b></p> <p>1 Combined pH / <math>E_0 = 7.0</math>            2 Combined pH / <math>E_0 = 7.0</math> / with Pt 100 (not GSA, SSA)</p> <p><b>Application range</b></p> <p>AB pH = 1 ... 12, T = -15 ... 80 °C, 1 diaphragm            AC pH = 1 ... 12, T = -15 ... 80 °C, 3 diaphragms            BB pH = 0 ... 14, T = 0 ... 130 °C, 1 diaphragm            BC pH = 0 ... 14, T = 0 ... 130 °C, 3 diaphragms (not ESS)</p> <p><b>Shaft length</b></p> <p>2 120 mm (only ESS, SSA,)            4 225 mm (only GSA, ESA)            5 360 mm (only ESS)</p> <p><b>Connection head</b></p> <p>GSA Threaded plug-in head Pg 13.5            SSA Hose connection head Pg 13.5            HDA Threaded plug-in head Pg 13.5, TOP 68, 16 bar            ESS Hose connection head Pg 13.5, TOP 68            ESA Threaded plug-in head Pg 13.5, TOP 68            SME Threaded plug-in head Pg 13.5, SMEK</p>				
CPS 41-				complete order code
Redox electrodes CeraLiquid P CPS 42				
<p><b>Electrode type</b></p> <p>0 Standard version</p> <p><b>Measuring element</b></p> <p>PB Platinum ring</p> <p><b>Shaft length</b></p> <p>2 120 mm (only SSA, ESS)            4 225 mm (only GSA)</p> <p><b>Connection head</b></p> <p>GSA Threaded plug-in head Pg 13.5            HDA Threaded plug-in head Pg 13.5, TOP 68, 16 bar            SSA Hose connection head Pg 13.5            ESA Threaded plug-in head Pg 13.5, TOP 68            ESS Hose connection head Pg 13.5, TOP 68            SME Threaded plug-in head Pg 13.5, SMEK</p>				
CPS 42-				complete order code
Reference electrodes CeraLiquid P CPS 43 (for combination with pH single electrodes CPS 64)				
<p><b>Electrode type</b></p> <p>0 Standard version</p> <p><b>Electrolyte</b></p> <p>TB Liquid KCl</p> <p><b>Shaft length</b></p> <p>2 120 mm</p> <p><b>Connection head</b></p> <p>SSA Hose connection head Pg 13.5            ESS Hose connection head Pg 13.5, TOP 68            HDA Threaded plug-in head Pg 13.5, TOP 68, 16 bar            SME Threaded plug-in head Pg 13.5, SMEK</p>				
CPS 43-				complete order code

**Endress+Hauser GmbH+Co.**  
**- Instruments International -**  
 P.O. Box 2222  
 D-79574 Weil am Rhein  
 Tel. (07621) 975 - 02  
 Fax (07621) 975345

**Endress+Hauser**  
 The Power of Know How

