



MAX30

INTEGRATED CYLINDER POSITION MEASUREMENT
FOR MOBILE MACHINES

Linear encoders

SICK
Sensor Intelligence.

INTEGRATED CYLINDER POSITION MEASUREMENT FOR MOBILE MACHINES

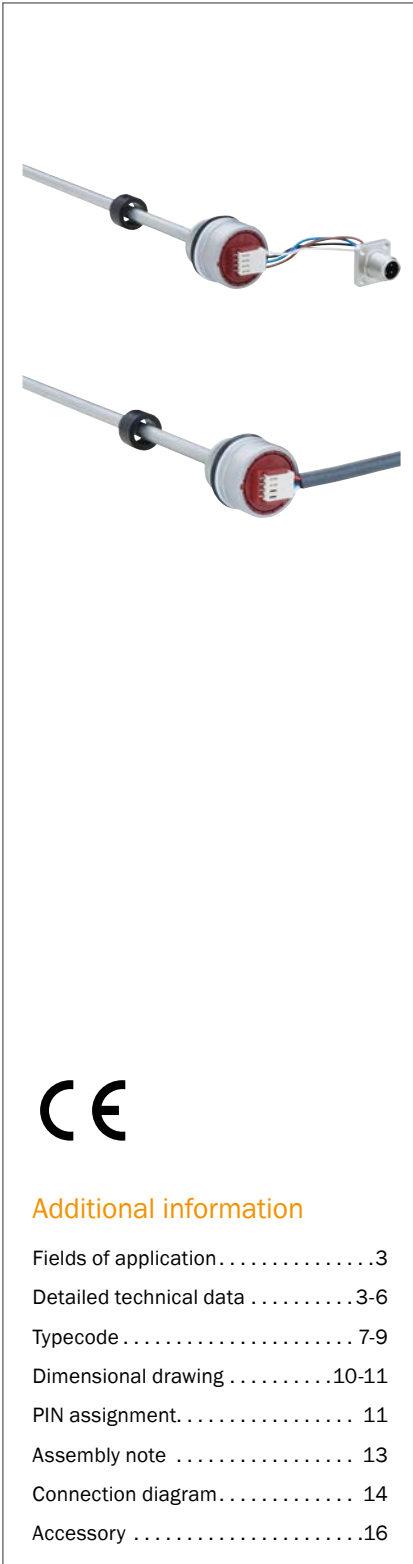

Additional information

Fields of application	3
Detailed technical data	3-6
Typecode	7-9
Dimensional drawing	10-11
PIN assignment	11
Assembly note	13
Connection diagram	14
Accessory	16

Product description

The MAX30 linear encoder enables non-contact, completely integrated and absolute position measurement in hydraulic cylinders. Suitable for use under extreme ambient and operating conditions in applications in mobile machines. The innovative technology of magnetostriction offers high reliability,

expanded diagnostic functions and well as a considerable reduction in operating costs. The 30 mm housing can be easily installed in the existing cylinder construction. All in all, linear encoders from SICK impress with their attractive cost-benefit ratio.

At a glance

- Measuring range: 50 to 1,500 mm (1 mm steps), typical resolution 0.1 mm
- Analog, CANopen, SAE J1939 and PWM interfaces are available
- Pressure-resistant housing, designed for hydraulic operating pressure of up to 320 bar
- High operating temperature (electronics) up to +105 °C
- Fluid temperature (hydraulic oil) up to max. +95 °C
- Compact dimensions: 10 mm installation space, 30 mm damping zone
- Position magnet does not need a spacer disk

Your benefits

- Reliable, safe and wear-free due to magnetostriction
- Mechanically and electrically compatible with existing constructions
- Very good utilization of the piston stroke, even if the installation space in the cylinder is very tight.
- Extremely stable signal behavior and very good EMC properties: resistant to radiated or coupled faults in the on-board electrical power supply
- Thanks to the large temperature range compared to other devices, it is more resistant to thermal stresses caused by hot fluids
- Monitoring of hydraulic cylinders: storage of power-up cycles, piston path, fluid temperature and supply voltage
- Good cost-benefit ratio

→ www.sick.com/MAX30

For more information, simply enter the link or scan the QR code and get direct access to technical data, CAD design models, operating instructions, software, application examples, and much more.



Fields of application

Mobile work equipment

- Steering cylinder and spring systems
- Lifting and press cylinders on garbage trucks
- Stroke, swivel and tilt cylinders on telescopic handlers
- Support cylinders on work platforms
- Cutting system adjustment, steering assistance
- Loading crane monitoring, boom cylinders
- Gripper monitoring field on container cranes

Detailed technical data

General notes

Note	Accessories not included with delivery, please order separately.
-------------	--

Performance

	Analog	PWM	Digital
Measured values	Position		Position, speed
Measuring range			
Position (F.S.)	50 ... 1,500 mm ¹⁾		
Speed	-		0 ... 1,000 mm/s
Unusable range			
Null zone	21.5 mm		
Damping zone	30 mm, 36 mm, 63 mm (depending on type)		
Switch-on time	< 250 ms		
Measuring frequency (internal)	2 ms		1 ms
Transmission rate (cycle time)	Continuous analog output signal	Depending on type, PWM frequency	-CANopen (0 ... 65,535 ms) Factory setting: 0 ms (transmission stopped) -SAE J1939: 20 ms
Setting point tolerance			
(Zero point and F.S.)	≤ ± 1 mm		
Resolution	Typ. 0.1 mm (noise-free)		
Hysteresis	± 0.1 mm		
Repeatability	Typ. ±0.2 mm		
Linearity (in the operational status)	Typ. ± 0.25 mm (measuring range 50 to 500 mm) Typ. ± 0.04 % F.S. (measuring range from 500 to 1,500 mm)		
Temperature drift			
Self-heating of the electronics (Warm-up phase)	Typ. ≤ ± 0.25 mm (2 min)		
Operational status (Hydraulic oil at operating temperature)	≤ ± 0.005 % x F.S. x ΔT (ΔT 40°C) ²⁾		
MTTF_d	69 years (EN ISO 13849-1) ^{3) 4)}		

¹⁾ F.S. = Full Scale (Measuring range)

²⁾ Increase in oil temperature by 40°C during operation.

³⁾ This product is a standard product and does not constitute a safety component as defined in the Machinery Directive. Calculation based on nominal load of components, average ambient temperature of electronic 60°C, frequency of use 8760 h/a.

⁴⁾ Every second failure of an electronic component is regarded as a dangerous failure.

Interfaces

	Analog	PWM	Digital
Communication interface detail	Voltage / current	PWM	CANopen / SAE J1939
Voltage output	0.25 ... 4.75 V 0.50 ... 4.50 V 0.50 ... 9.50 V 1.00 ... 9.00 V 9.50 ... 0.50 V 9.00 ... 1.00 V 4.75 ... 0.25 V 4.50 ... 0.50 V	–	
Current output	4.00 ... 20.00 mA 20.00 ... 4.00 mA	–	
Bus protocol	–		CANopen CiA DS-301
Device profile	–		CANopen CiA DS-406
Network Management Protocol	–		SAE J1939-81
Application Layer	–		SAE J1939-71
Puls width	–	05% ... 95% 10% ... 95% 15% ... 85% 20% ... 80% 25% ... 75%	–
Frequency	–	250 Hz 300 Hz 400 Hz 500 Hz	–

Electrical data

	Analog	PWM	Digital
Connection type	M12 connector, 4-pin Connecting cable, 3-wire		M12 connector, 5-pin
Supply voltage			
12 V DC	8 ... 16 V DC ¹⁾	–	
24 V DC	13 ... 36 V DC ^{2),3)}	–	
24 V DC	8 ... 36 V DC		
Residual ripple	< 1% S-S		
Power consumption			
12 V DC	≤ 0.75 W ¹⁾	–	
24 V DC	≤ 1.25 W ^{2),3)}	–	
24 V DC	≤ 0.75 W		
Current consumption			
12 V DC	≤ 60 mA ¹⁾	–	
24 V DC	≤ 50 mA ^{2),3)}	–	
24 V DC	≤ 30 mA		
Load resistance			
Voltage signal	RL ≥ 10 kΩ	–	
Current signal	100 Ω ≤ RL ≤ 500 Ω	–	
Bustermination	–		120 Ω
Switch-on current			
12 V DC	Typ. 2.5 A/ 50 μs	–	
24 V DC	Typ. 5.0 A/ 50 μs		

	Analog	PWM	Digital
Over voltage protection			
12 V DC	≤ 18 V at all poles during the switch-on process (60 s) ≤ 24 V to GND during the switch-on process (60 s)		
24 V DC	≤ 36 V at all poles during the switch-on process (60 s) ≤ 48 V to GND during the switch-on process (60 s)		
Reverse polarity protection	≤ 36 V (at all poles) (ISO 16750-2)		
Insulation resistance	$R_{iso} \geq 10 \text{ M}\Omega$, 60s (ISO 16750-2)		
Dielectric strength	500 V (0 V against housing) (ISO 16750-2)		

¹⁾ Valid for voltage outputs 0.50 ... 4.50 V; 4.50 ... 0.50 V; 0.25 ... 4.75 V ; 4.75 ... 0.25 V

²⁾ Valid for voltage output 0.5 ... 9.5 V and 9.50 ... 0.50 V

³⁾ Valid for current output 4 ... 20 mA; 20 ... 4 mA

Mechanical data

	Analog	PWM	Digital
Dimensions			
Construction size	31f7 mm (for installation in drill hole 31H8)		
Ø pressure pipe	7 mm		
Ø O-Ring	Ø 24.99 mm x 3.53 mm		
Ø support ring	Ø 31 mm x Ø 25.8 mm x 1.4 mm		
M12 flange type S	Construction DM 20x20 mm - hole pattern 14 mm (EN 61076-2-101)		
M12 flange type L	Construction DM 24x24 mm - hole pattern 17 mm (EN 61076-2-101)		
M12 connector (stranded wires)	60 ... 240 mm (depending on type)		
Connecting cable / Stripped wires	Ø 5.0 mm / Ø 1.4 mm 300 ... 10,000 mm (depending on type) 3 x 0.38 mm ² (AWG22)		
Material			
Electronics enclosure	Stainless steel 1.4305, AISI 303		
Pressure pipe	Stainless steel 1.4404, AISI 316L		
O-ring	NBR 70		
Support ring	PTFE		
Connection inlay	Glass fiber reinforced polyamide, nickel-/gold-plated brass contacts		
M12 flange	Nickel-plated brass with O-ring (NBR)		
Connecting cable/ stranded wire	PUR / PVC		

Ambient data

	Analog	PWM	Digital
EMC	EU Directive 2014/30/EU		
Agricultural and forestry machinery	ISO 14982		
Construction machinery	EN 13309/ISO 13766		
Transient pulses	ISO 7637-2		
ESD (air and contact discharge)	EN 61000-4-2, ISO/TR 10605		
Enclosure rating			
Housing without electrical connection	IP67 (EN 60529)		
Housing with connecting cable	IP67 (EN 60529)		
M12 connector	IP69k (ISO 20653)		
Temperature			
Operating temperature range (electronics)	-40 °C ... +105 °C ¹⁾		
Ambient temperature (fluid)	-30 °C ... +95 °C ²⁾		
Storage temperature range	-20 °C ... +65 °C ³⁾⁴⁾		
Permissible relative humidity	90 % (Condensation not permitted)		
Resistance to shocks	Fall test in acc. with IEC 60068-2-31 100 g, 11 ms (Single shock in acc. with IEC 60068-2-27) 50 g, 11 ms (Continuous shocks, 1,000 shocks per spatial axis in acc. with IEC 60068-2-27)		
Resistance to vibration			
Sinus	15 g, 24 h / spatial axis, 55 ... 2,000 Hz (IEC 60068-2-6)		
Sinus noise	13 g (r.m.s), 36 h / spatial axis, 10 ... 2,000 Hz (IEC 60068-2-80)		
Noise (resonance points excluded)	15 g (r.m.s), 48 h / spatial axis, 10 ... 2,000 Hz (IEC 60068-2-64)		
Nominal operating pressure (P_N)	320 bar		
Max. overload pressure during operation (P_N x 1.2)	380 bar		
Max. test pressure in cylinder (P_N x 1.5)	480 bar		

¹⁾ Considered self-heating caused by continuously electrical operation with applied supply voltage.

²⁾ Due to permissible temperature loads of O-ring seals, hydraulic oil and the temperature-dependent signal quality of the position magnet.

³⁾ Relative Humidity 55 %

⁴⁾ Due to the dry storage of the O-ring when not installed (not wetted by hydraulic oil).

For details of applied tests and descriptive standards, please see document 8021473.

Typecode

Analog

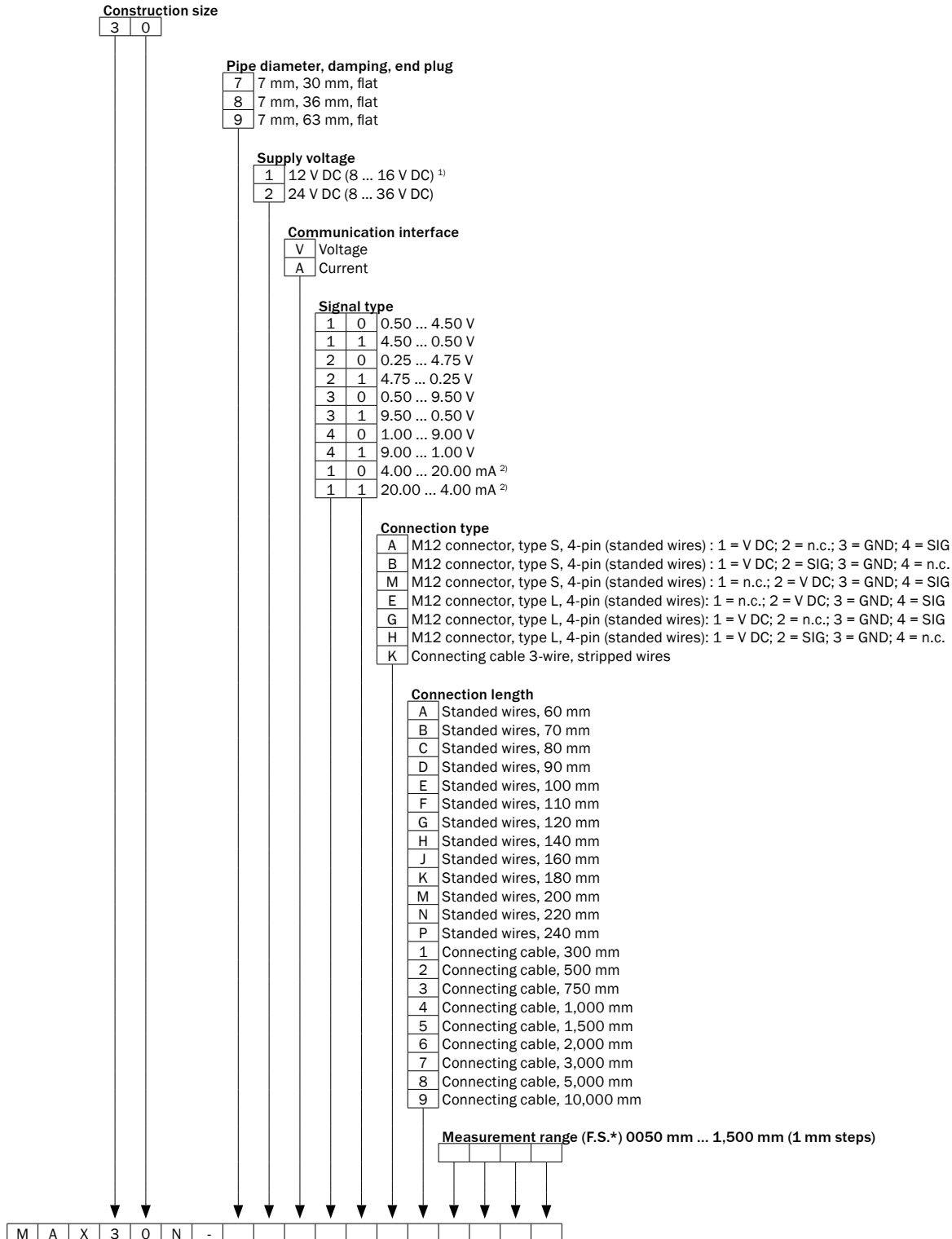

¹⁾ Only in combination with voltage output (signal type V10, V11, V20, V21)

²⁾ Only in combination with communication interface A

* Full Scale (measuring range end value)

PWM

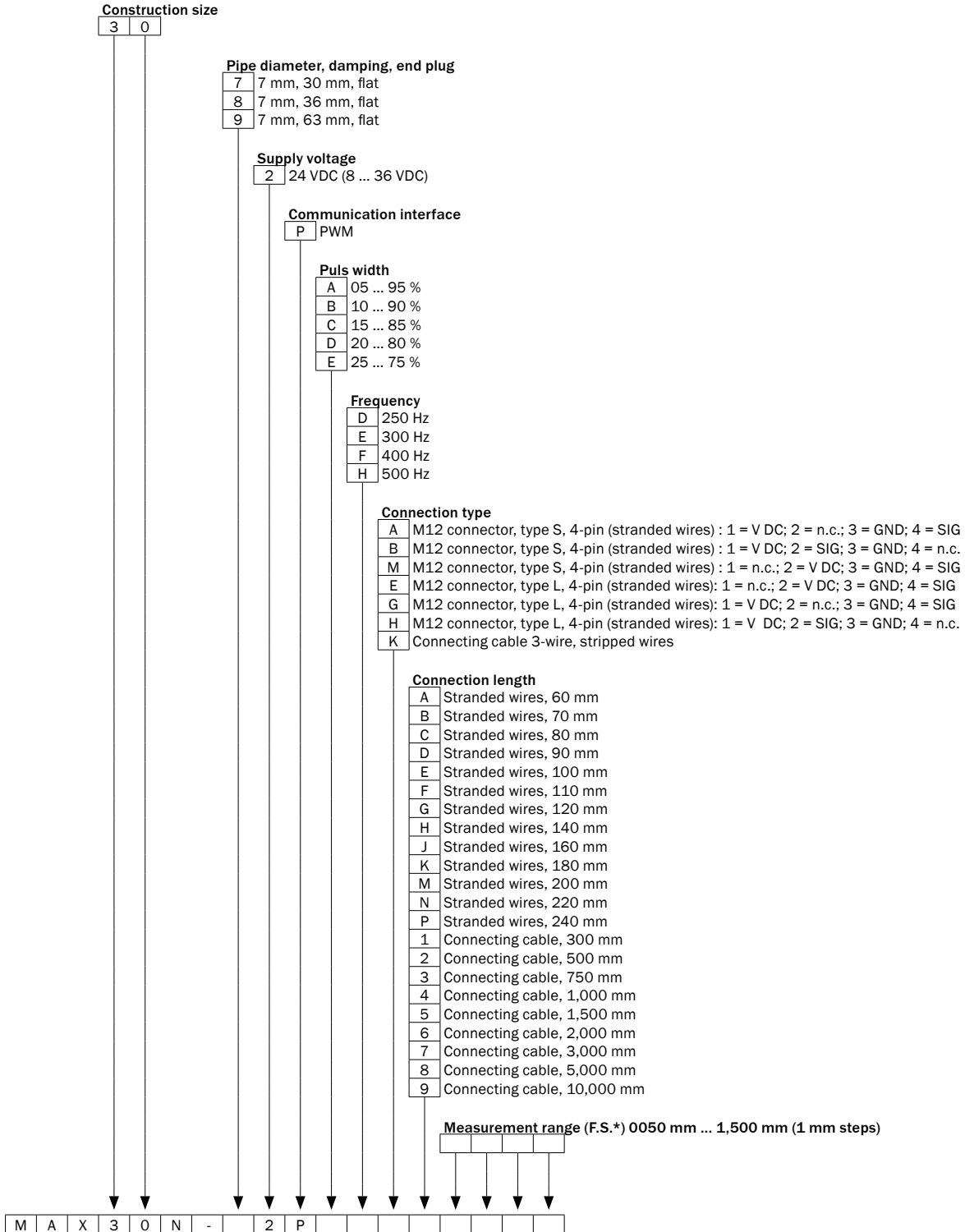

* Full Scale (measuring range end value)

Digital

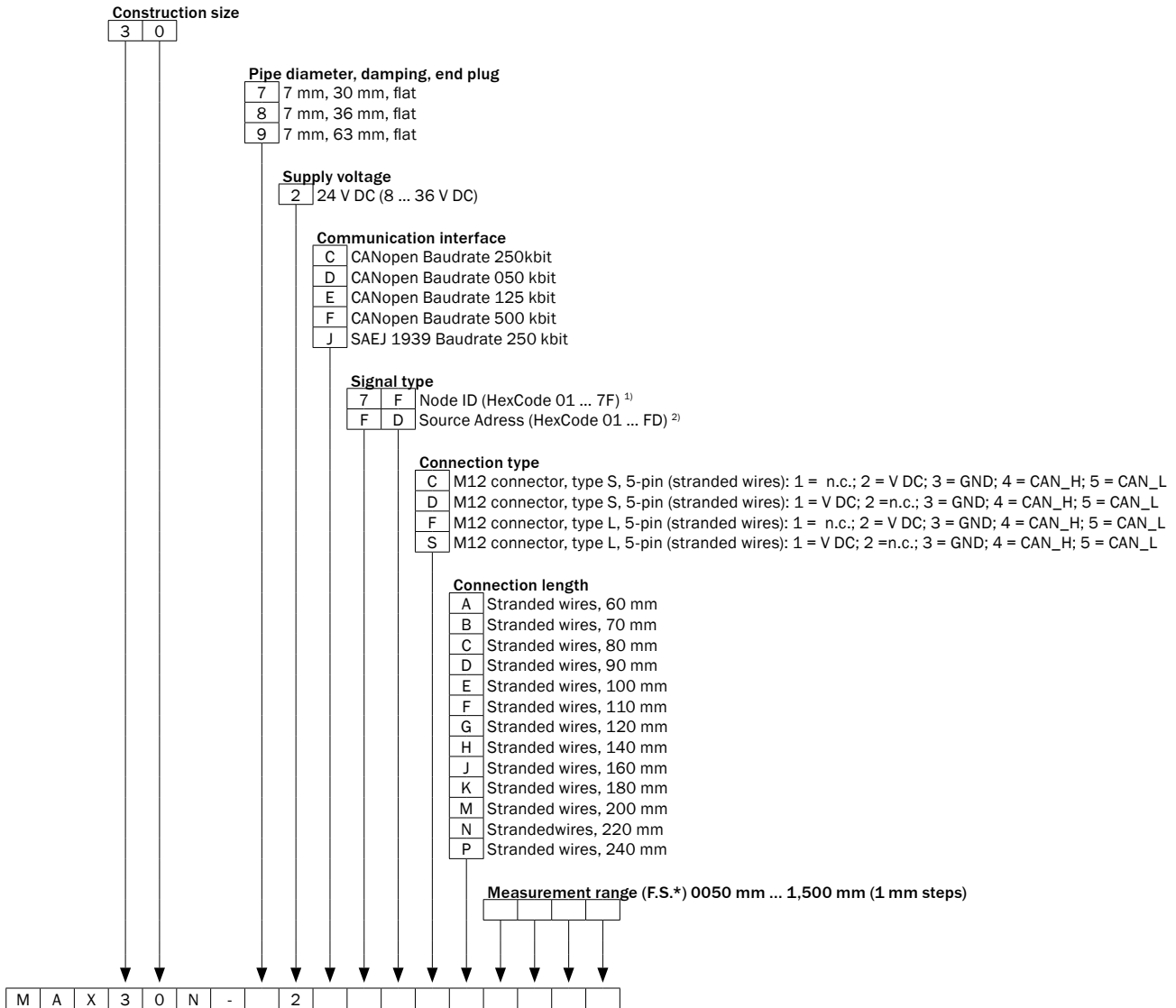

¹⁾ Only in combination with communication interface CANopen
²⁾ Only in combination with communication interface SAEJ 1939
 * Full Scale (measuring range end value)

MAX30

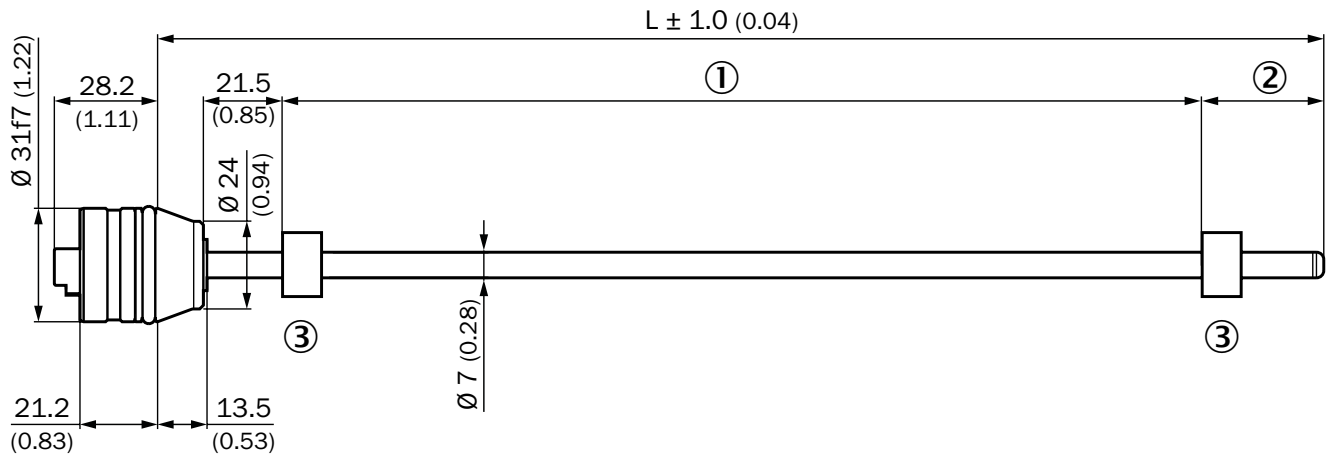

- ① Measuring range
- ② Damping zone
- ③ Position magnet

MAX30 Housing

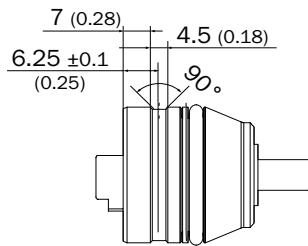

Encoder with electrical connection

M12 connector (Analog/ PWM/ Digital interface)

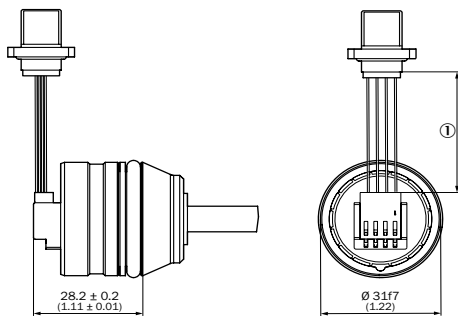

① Stranded wires length (depending on type)

Encoder with electrical connection

M12 connector type S/ flange - axial seal

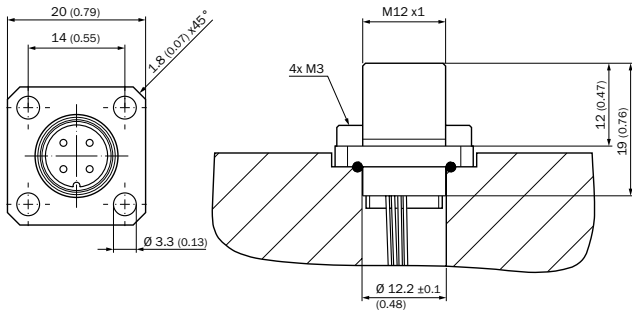

M12 connector type L/ flange - radial seal

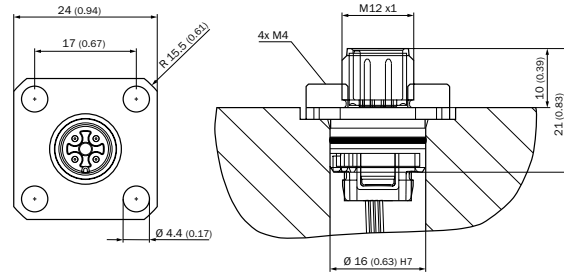

PIN assignment

M12 connector (4-pin design for Analog and PWM interface)

PIN assignment A (Type S)

PIN assignment G (Type L)

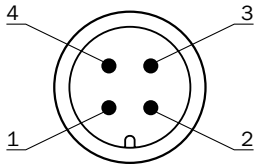

- ① V DC
- ② N.C.
- ③ GND
- ④ Signal

PIN assignment B (Type S)

PIN assignment H (Type L)

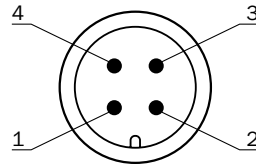

- ① V DC
- ② Signal
- ③ GND
- ④ N.C.

PIN assignment M (Type S)

PIN assignment E (Type L)

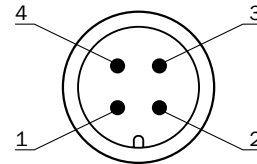

- ① N.C.
- ② V DC
- ③ GND
- ④ Signal

M12 connector (5-pin design for Digital interface)

PIN assignment D (Type S)

PIN assignment S (Type L)

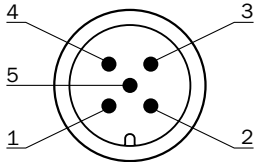

- ① V DC
- ② N.C.
- ③ GND
- ④ CAN_H
- ⑤ CAN_L

PIN assignment C (Type S)

PIN assignment F (Type L)

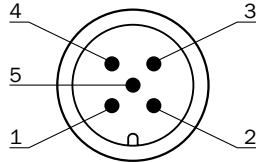

- ① N.C.
- ② V DC
- ③ GND
- ④ CAN_H
- ⑤ CAN_L

Encoder with electrical connection

Connecting cable 3-wire (Analog/ PWM interface)

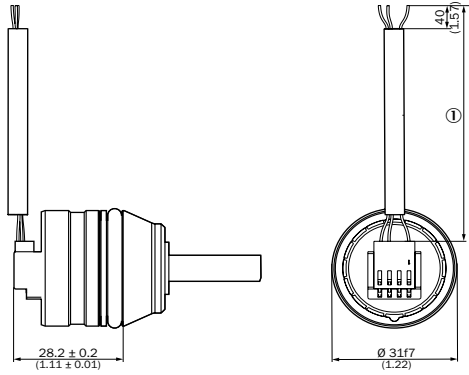

① Connecting cable length (depending on type)

Wire color	Terminal
brown	V DC
blue	GND
black	SIG (V)

Wire color	Terminal
brown	V DC
blue	GND
white	SIG (mA)

Encoder with electrical connection - connecting cable

Cable fitting mount

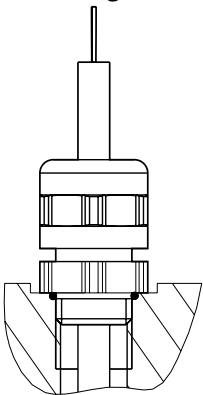

Assembly note

IN-cylinder assembly

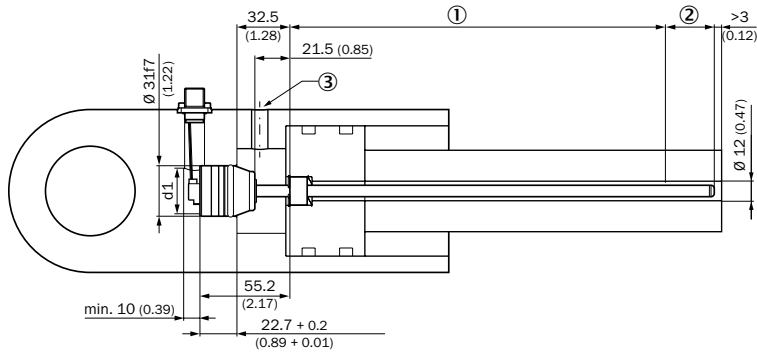

- ① Measuring range
- ② Damping zone

Please observe the information in the operating instructions (8021473) (d: 26.5 ≤ d ≤ 28).

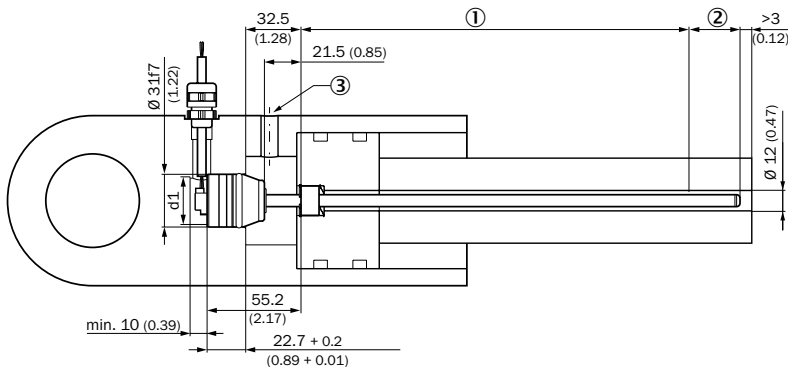

- ① Measuring range
- ② Damping zone

Please observe the information in the operating instructions (8021473) (d: 26.5 ≤ d ≤ 28).

Installation of the position magnet

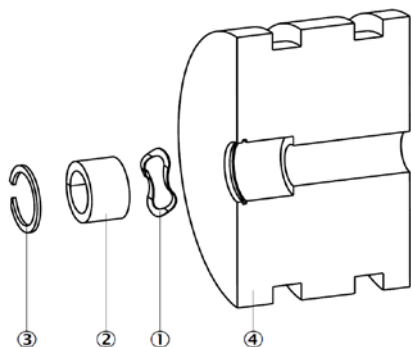

- ① Corrugated spring washer
- ② Position magnet
- ③ Circlip
- ④ Piston

Connection diagram

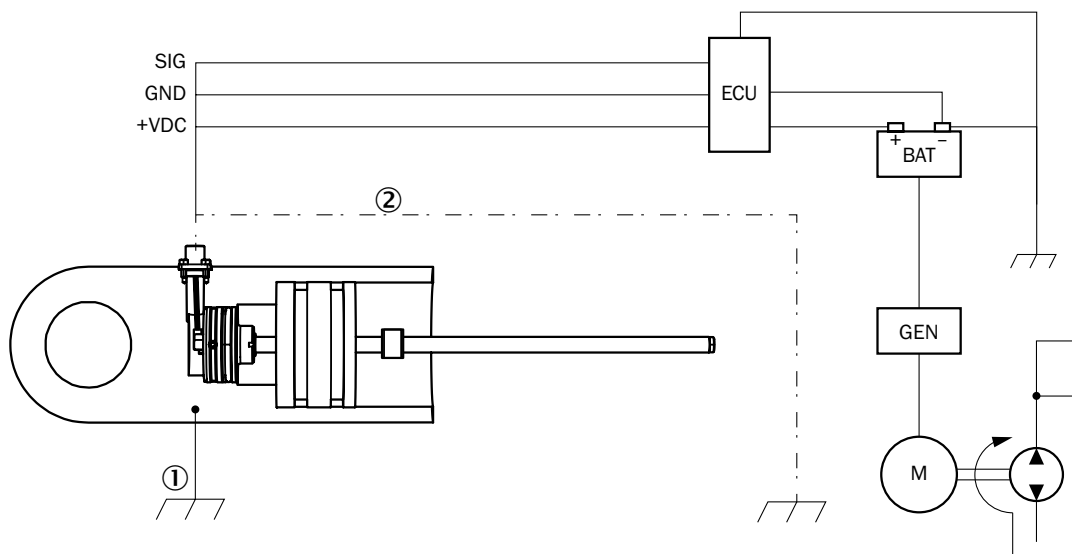

- ① Chassis GND
- ② Cable shielding (optional)

Accessories

Mounting systems

Flanges



Flange plates

Figure	Brief description	Packaging unit	Type	Part no.
	Flange for M12 male connector, type L square flange (24 mm x 24 mm) with axial seal, nickel-plated brass	1	BEF-FA-M12L-01	2117510
		5	BEF-FA-M12L-05	2117511
		10	BEF-FA-M12L-10	2117512
	Flange for M12 male connector, type S square flange (20 mm x 20 mm) with axial seal, nickel-plated brass	1	BEF-FA-M12S-01	2117507
		5	BEF-FA-M12S-05	2117508
		10	BEF-FA-M12S-10	2117509

Dimensional drawings → [page 16](#)

Other mounting accessories

Others

Figure	Brief description	Packaging unit	Type	Part no.
	Circlip for installing the position magnets in the piston of the hydraulic cylinder, stainless steel 1.4300 / SAE 302	1	BEF-MK-SR-01	2116437
		5	BEF-MK-SR-05	2116438
		10	BEF-MK-SR-10	2116439
		50	BEF-MK-SR-50	2116440
	Corrugated spring washer for installing the position magnets in the piston of the hydraulic cylinder, stainless steel 1.4568 / SAE 631	1	BEF-MK-WF-01	2116431
		5	BEF-MK-WF-05	2116432
		10	BEF-MK-WF-10	2116433
		50	BEF-MK-WF-50	2116435

Dimensional drawings → [page 16](#)

Connection systems

Plug connectors and cables

Other connectors and cables

Figure	Brief description	Packaging unit	Type	Part no.
	Head A: M12 Cable: shielded Cable gland with M12 x 1.5 connection thread, polyamide V0 terminal insert in accordance with UL94, NBR O-ring, NBR molded seal, WAF 14	1	BEF-EA-M12-S	2117513

Dimensional drawings → [page 16](#)

Further accessories

Magnets

Figure	Brief description	Packaging unit	Type	Part no.
	Position magnet for magnorestrictive linear encoder, Ø 17.4 mm	1	MAG-O-174-01	2112714
		5	MAG-O-174-05	2112713
		10	MAG-O-174-10	2115045
		50	MAG-O-174-50	2112711

Dimensional drawings → [page 16](#)

Dimensional drawings for accessories (Dimensions in mm (inch))

Flanges

Square flange type L (BEF-FA-M12L-xx)

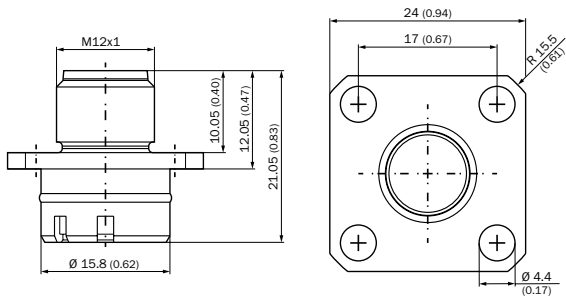

Square flange type S (BEF-FA-M12S-xx)

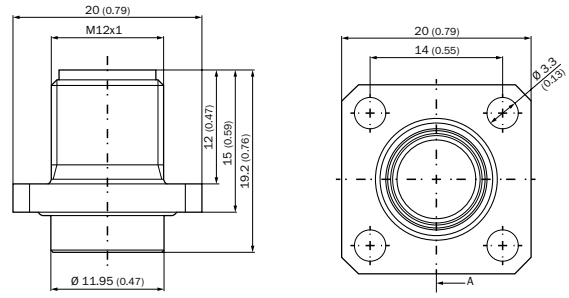

Other mounting accessories

Position magnet (MAG-O-174-xx)

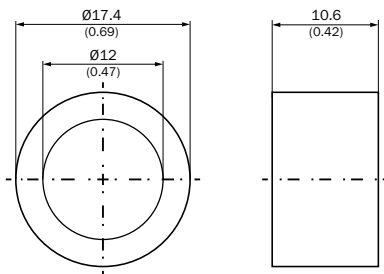

Circlip (BEF-MK-SR-xx)

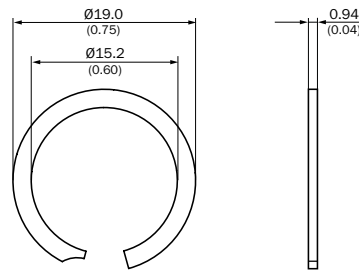

Spring washer (BEF-MK-WF-xx)

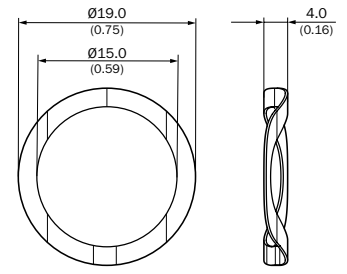

Plug connectors and cables

Cable gland (BEF-EA-M12-S)

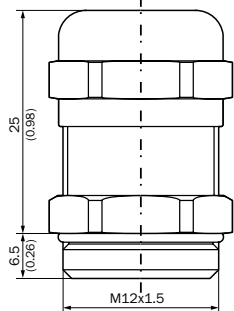

REGISTER AT WWW.SICK.COM TODAY AND ENJOY ALL THE BENEFITS

- ✔ Select products, accessories, documentation and software quickly and easily.
- ✔ Create, save and share personalized wish lists.
- ✔ View the net price and date of delivery for every product.
- ✔ Requests for quotation, ordering and delivery tracking made easy.
- ✔ Overview of all quotations and orders.
- ✔ Direct ordering: submit even very complex orders in moments.
- ✔ View the status of quotations and orders at any time. Receive e-mail notifications of status changes.
- ✔ Easily repeat previous orders.
- ✔ Conveniently export quotations and orders to work with your systems.

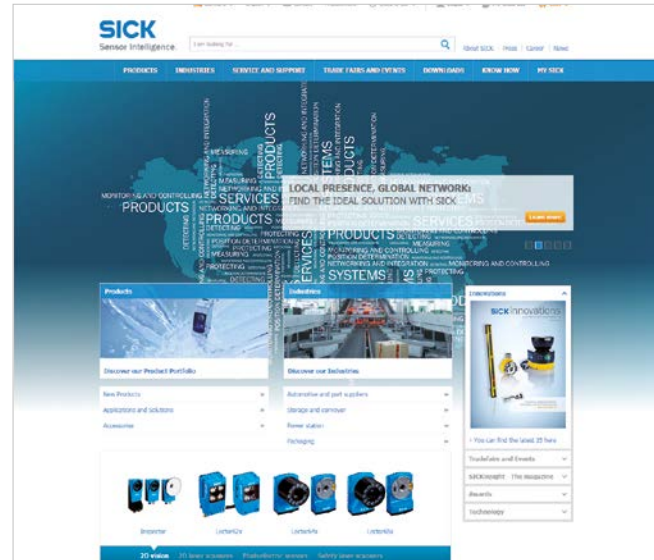

SERVICES FOR MACHINES AND SYSTEMS: SICK LifeTime Services

Our comprehensive and versatile LifeTime Services are the perfect addition to the comprehensive range of products from SICK. The services range from product-independent consulting to traditional product services.



Consulting and design
Safe and professional



Product and system support
Reliable, fast and on-site



Verification and optimization
Safe and regularly inspected



Upgrade and retrofits
Easy, safe and economical



Training and education
Practical, focused and professional

SICK AT A GLANCE

SICK is a leading manufacturer of intelligent sensors and sensor solutions for industrial applications. With more than 10,000 employees and over 50 subsidiaries and equity investments as well as numerous agencies worldwide, SICK is always close to its customers. A unique range of products and services creates the perfect basis for controlling processes securely and efficiently, protecting individuals from accidents, and preventing damage to the environment.

SICK has extensive experience in various industries and understands their processes and requirements. With intelligent sensors, SICK delivers exactly what the customers need. In application centers in Europe, Asia, and North America, system solutions are tested and optimized in accordance with customer specifications. All this makes SICK a reliable supplier and development partner.

Comprehensive services round out the offering: SICK LifeTime Services provide support throughout the machine life cycle and ensure safety and productivity.

That is “Sensor Intelligence.”

Worldwide presence:

Australia, Austria, Belgium, Brazil, Canada, Chile, China, Czech Republic, Denmark, Finland, France, Germany, Great Britain, Hungary, Hong Kong, India, Israel, Italy, Japan, Malaysia, Mexico, Netherlands, New Zealand, Norway, Poland, Romania, Russia, Singapore, Slovakia, Slovenia, South Africa, South Korea, Spain, Sweden, Switzerland, Taiwan, Thailand, Turkey, United Arab Emirates, USA, Vietnam.

Detailed addresses and further locations → www.sick.com