

Type 8635 SideCONTROL

Electropneumatic positioner



Operating Instructions

We reserve the right to make technical changes without notice.

© Bürkert Werke GmbH & Co. KG, 2003-2020

Operating Instructions 2002/07_EN-en_00804608 / Original DE

1	OPERATING INSTRUCTIONS	6
1.1	Symbols	6
1.2	Definition of terms	6
2	INTENDED USE	7
3	BASIC SAFETY INSTRUCTIONS	8
4	GENERAL NOTES.....	9
4.1	Contact addresses.....	9
4.2	Warranty.....	9
4.3	Master code	9
4.4	Information on the Internet.....	9
5	PRODUCT DESCRIPTION.....	10
5.1	Product variants	11
5.2	Options	12
5.3	Functional diagram.....	13
5.4	Interfaces	14
5.5	Operation as positioner.....	15
5.6	Operation as a process controller (option).....	16
6	TECHNICAL DATA	18
6.1	Conformity	18
6.2	Standards.....	18
6.3	Type label	18
6.4	Operating conditions.....	19
6.5	Safety end positions after failure of the electrical or pneumatic auxiliary power	21
7	DIRECT ATTACHMENT TO BÜRKERT CONTROL VALVES	22
8	INSTALLATION OF THE REMOTE VARIANT.....	23
8.1	Wall mounting with mounting bracket	24
8.2	“Position sensor Remote” attachment kit.....	25
8.3	Mounting the position sensor on the actuator:.....	26
8.4	Connecting the position sensor electrically	27
8.5	Connecting the position sensor pneumatically.....	28
9	DIRECT ATTACHMENT OF THE LINEAR ACTUATOR.....	29
9.1	Attachment kit for linear actuators.....	30
9.2	Mounting the hoop and lever.....	31
9.3	Attaching the mounting bracket.....	32
9.4	Aligning the lever mechanism	34
10	DIRECT ATTACHMENT TO THE ROTARY ACTUATOR.....	35
10.1	Attachment kit for rotary actuators	35
10.2	Mounting the SideControl on the rotary actuator	36
11	PNEUMATIC CONNECTION.....	38

MAN 1000011213 EN Version: L Status: RL (released | freigegeben) printed: 08.05.2026

12	ELECTRICAL CONNECTION	39
13	OPERATING AND DISPLAY ELEMENTS	41
13.1	Assignment of the keys.....	41
14	OPERATING LEVELS	42
15	OPERATING STATES	43
15.1	Changing the operating state.....	43
15.2	Detecting the operating state.....	43
16	AUTOMATIC OPERATING STATE DURING POSITION CONTROL	44
16.1	Meaning of the keys.....	44
16.2	Displays in AUTOMATIC operating state:	44
17	AUTOMATIC OPERATING STATE DURING PROCESS CONTROL	45
17.1	Meaning of the keys.....	45
17.2	Displays in AUTOMATIC operating state:	45
18	BASIC FUNCTIONS AND AUXILIARY FUNCTIONS	47
18.1	Main menu with the basic functions	47
18.2	Function of the keys in the main menu and ADDFUNCT	47
18.3	Auxiliary functions that can be enabled	48
18.4	Factory settings of the auxiliary functions	49
18.5	Enabling and disabling auxiliary functions.....	50
18.6	Setting numerical values.....	51
18.7	Overview of the auxiliary functions	52
19	DESCRIPTION OF THE AUXILIARY FUNCTIONS	53
19.1	CHARACT: Selecting the characteristic type.....	53
19.2	CUTOFF: Sealing function	56
19.3	DIR.CMD: Effective direction of the set-point value for setting the valve position.....	57
19.4	DIR.ACT: Setting the effective direction of the pressurisation state of the actuator to the actual position.....	58
19.5	SPLTRNG: Splitting the standard signal range	59
19.6	X.LIMIT: Limiting the mechanical stroke range.....	60
19.7	X.TIME: Reducing the control speed	61
19.8	X.CONTRL Parameterising the position control.....	62
19.9	P.CONTRL: Parameterising the process control	63
19.10	P.Q'LIN: Linearisation of the process characteristic	67
19.11	CODE: Code protection for settings	68
19.12	SAFEPOS Setting the safety position	69
19.13	SIG-ERR Configuring the signal error detection	70
19.14	BIN-IN: Setting the function of the digital input.....	71
19.15	OUTPUT: Configuring outputs (option).....	72
19.16	CAL.USER: Changes to the factory calibration through the user	75
19.17	SET.FACT: Factory reset	76

20	START-UP AS POSITIONER.....	77
	20.1 Carry out the X.TUNE function (AUTOTUNE).....	78
	20.2 X.TUNE function - manual TUNE.....	80
21	START-UP AS PROCESS CONTROLLER.....	82
	21.1 Sequence of the work steps.....	82
	21.2 P.TUNE: Carrying out self-optimisation of the process controller.....	83
	21.3 Manual changing of the process set-point value.....	86
22	MAINTENANCE AND TROUBLESHOOTING.....	87
	22.1 Maintenance.....	87
	22.2 Error messages, position control.....	87
	22.3 Error messages, process control.....	89
23	ACCESSORIES.....	90
24	PACKAGING, TRANSPORT.....	91
25	STORAGE.....	91
26	DISPOSAL.....	91
27	ADDITIONAL INFORMATION.....	92
	27.1 Selection criteria for control valves.....	92
	27.2 Properties of PID controllers.....	94
	27.3 Rules for adjusting PID controllers.....	99
28	MENU STRUCTURE OF THE SOFTWARE.....	103
29	APPENDIX.....	104
	29.1 Settings of the freely programmable characteristic.....	104
	29.2 Set process control parameters.....	105

1 OPERATING INSTRUCTIONS

The operating instructions describe the entire life cycle of the device. Keep these instructions in a location which is easily accessible to every user and make them available to every new owner of the device.

Important safety information!

Carefully read through the operating instructions. In particular, pay attention to section “[Intended use](#)” and “[Basic safety instructions](#)”.

- ▶ The operating instructions must be read and understood.

1.1 Symbols



DANGER

Warns of an immediate danger.

- ▶ Failure to observe will result in death or serious injuries.



WARNING

Warns of a potentially hazardous situation.

- ▶ Failure to observe these instructions may result in serious injuries or death.



CAUTION

Warns of a potential danger.

- ▶ Failure to observe may result in moderate or minor injuries.

NOTE

Warns of damage.

- ▶ Failure to observe may result in damage to the device or the system.



indicates important additional information, tips and recommendations.



refers to information in these operating instructions or in other documentation.

- ▶ designates instructions to avoid a danger.
- designates a procedure which you must carry out.
- ✓ designates a result.

1.2 Definition of terms

In these instructions, the term “device” always refers to the SideControl Positioner Type 8635.

2 INTENDED USE

The SideControl Type 8635 has been designed for the position control of pneumatically actuated control valves with single-acting linear actuators or with single-acting rotary actuators.

- ▶ In potentially explosive atmospheres, only use devices that are approved for this purpose. These devices are marked with the ATEX logo on the type label. For use, observe the information on the type label and the additional instructions enclosed with the device, marked with the ATEX logo.
- ▶ Do not use devices without the ATEX logo on the type label in potentially explosive atmospheres.
- ▶ Do not expose the device to direct sunlight.
- ▶ To achieve a degree of protection of IP65, seal the cable entries tightly.
- ▶ Use the device only in its original condition and when it is in perfect working order.
- ▶ Use the device only in conjunction with third-party devices and components recommended or approved by Bürkert.
- ▶ Use the device only as intended. Non-intended use of the device may be dangerous to people, nearby equipment and the environment.
- ▶ Prerequisites for safe and trouble-free operation are correct transportation, correct storage, installation, start-up, operation and maintenance.
- ▶ To use the device, observe the permitted data, operating conditions and application conditions. These specifications can be found in the contract documents, the operating instructions and on the type label.

3 BASIC SAFETY INSTRUCTIONS

These safety instructions do not take into account any unforeseen circumstances and events which occur during installation, operation and maintenance.

The operator is responsible for observing the location-specific safety regulations, also with reference to the personnel.



Risk of injury due to high pressure and escaping medium.

- ▶ Before working on the device or system, switch off the pressure. Exhaust or empty the lines.

Risk of injury due to electric shock.

- ▶ Before working on the device or system, switch off the power supply. Secure against reactivation.
- ▶ Observe the applicable accident prevention and safety regulations for electrical devices.

General hazardous situations.

To prevent injuries, observe the following:

- ▶ Only trained technicians may perform installation and maintenance work.
- ▶ Perform installation work and maintenance work using suitable tools only.
- ▶ Do not modify the device.
- ▶ Do not mechanically load the device.
- ▶ Use the device only when it is in perfect working order and in accordance with the operating instructions.
- ▶ Secure the device or system to prevent unintentional activation.
- ▶ Following interruption of the process, ensure that the process is restarted in a controlled manner.
Observe the sequence:
 1. Connect the pneumatic and power supply.
 2. Charge with medium.
- ▶ Do not feed any aggressive or flammable media or liquids into the pressure port of the device.
- ▶ Observe the general rules of technology.
- ▶ Install the device according to the regulations applicable in the country of use.
- ▶ Observe the intended use.

NOTE

Electrostatically sensitive components / assemblies.

The device contains electronic components that are susceptible to the effects of electrostatic discharging (ESD). Components that come into contact with electrostatically charged persons or objects are at risk. In the worst case scenario, these components are destroyed immediately or fail after start-up.

- ▶ Meet the requirements specified by EN 61340-5-1 to minimise or avoid the possibility of damage caused by sudden electrostatic discharge.
- ▶ Do not touch electronic components when the supply voltage is connected.

4 GENERAL NOTES

4.1 Contact addresses

Germany

Bürkert Fluid Control Systems
Sales Centre
Christian-Bürkert-Str. 13-17
D-74653 Ingelfingen
Tel. + 49 (0) 7940 - 10 91 111 49
Fax + 0 (7940) 10 91 448 - 10-91 448
Email: info@burkert.com

International

The contact addresses can be found on the back pages of the printed Quickstart. The printed Quickstart is included in the scope of delivery of the device.

You can also find the contact addresses on the Internet at: www.burkert.com

4.2 Warranty

A precondition for the warranty is that the device is used as intended in consideration of the specified operating conditions.

4.3 Master code

Operation of the device can be locked via a freely selectable 4-digit code. Regardless of this, there is an unchangeable master code with which you can perform all operating actions on the device.

This 4-digit master code can be found on the back pages of the printed Quickstart. The printed Quickstart is included in the scope of delivery of the device.

If necessary, cut out the code and keep it separately from the operating instructions.

4.4 Information on the Internet

Operating instructions and data sheets for the Bürkert products can be found on the Internet at: www.burkert.com

5 PRODUCT DESCRIPTION

The SideControl Type 8635 is an electropneumatic positioner for pneumatically actuated control valves with single-acting stroke or rotary actuators.

The device controls the valve position according to the set-point position. The set-point position is specified by an external standard signal.

If equipped with a PID controller (optional), Type 8635 can be used as a process controller.

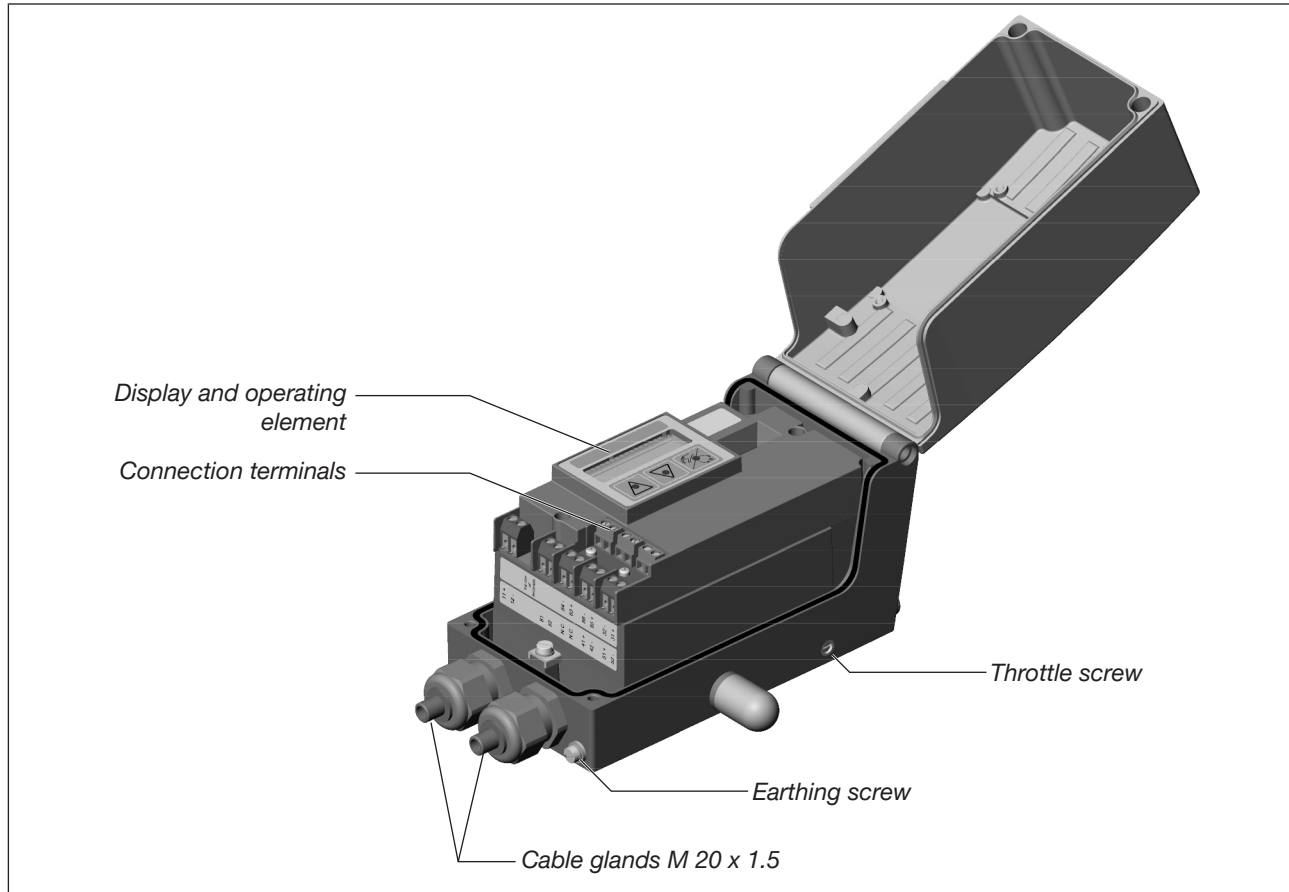

Figure 1: Structure of the SideControl Type 8635

5.1 Product variants

The SideControl Type 8635 is available in different variants depending on the actuator type of the control valve to be controlled.

5.1.1 Direct attachment to Bürkert control valves Type 27xx



For Bürkert control valves with external air routing, actuator sizes $\varnothing 175 + 225$ mm.

With pre-assembled cable (0.3 m) for connection to position sensor Type 8635.

In this variant, the SideControl Type 8635 is only supplied as part of a complete control system (SideControl + position sensor + associated attachments + control valve).

5.1.2 Remote variant for Bürkert control valves Type 23xx

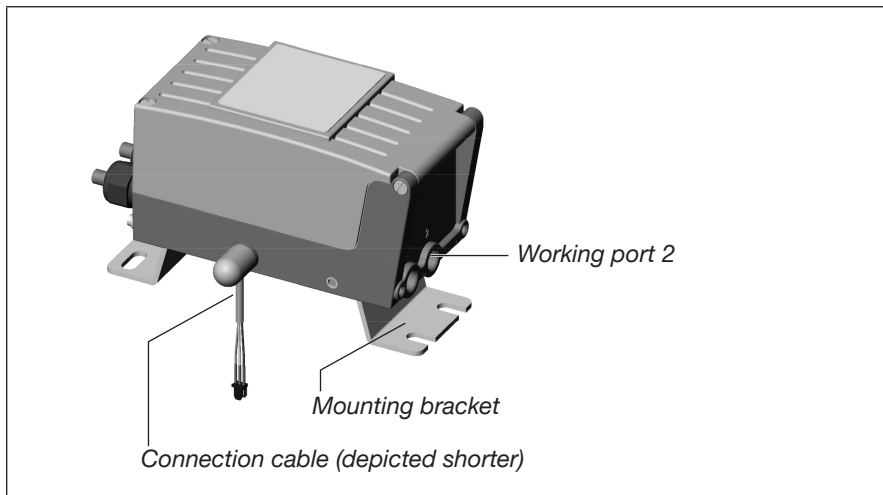

For Bürkert control valves with internal air routing, actuator sizes $\varnothing 70, 90 + 130$ mm.

With pre-assembled cable (2.5 m) for connection to the external position sensor.

With pre-assembled mounting bracket for wall mounting.

5.1.3 Direct attachment to rotary actuators or linear actuators



For attachment to external actuators according to NAMUR/IEC.
With integrated position sensor.

5.2 Options

5.2.1 Integrated process controller

Using a process controller with PID behaviour, it is possible to set up a decentralised closed-loop control. In addition to the valve position, measured variables such as level, pressure, flow or temperature can be controlled. The actual values of the measured variables to be controlled are determined via an integrated or external position sensor and via connected sensors, compared with the specified set-point values and corrected, if necessary.

5.2.2 Analogue feedback

Values such as actual position or process actual value can be output to the controller via the analogue feedback.

5.2.3 2 digital outputs

Various controller states can be output via the digital outputs. The setting options are described in detail in section [“19.15 OUTPUT: Configuring outputs \(option\)”](#) on page 72.

The digital outputs behave like a NAMUR sensor acc. to EN 60947-5-6.

5.2.4 ATEX approval EEx ia II C T6

In potentially explosive atmospheres, only use devices that are approved for this purpose.

These devices

- are marked with the ATEX logo on the type label and
- contain additional instructions marked with the ATEX logo in their scope of delivery.

When using these devices in potentially explosive atmospheres, observe the information on the type label and in the additional instructions.

5.3 Functional diagram

Functional diagram of the SideControl Type 8635 in conjunction with a control valve with a single-acting actuator. The grey areas show the additional functions when the device is used as a process controller (option).

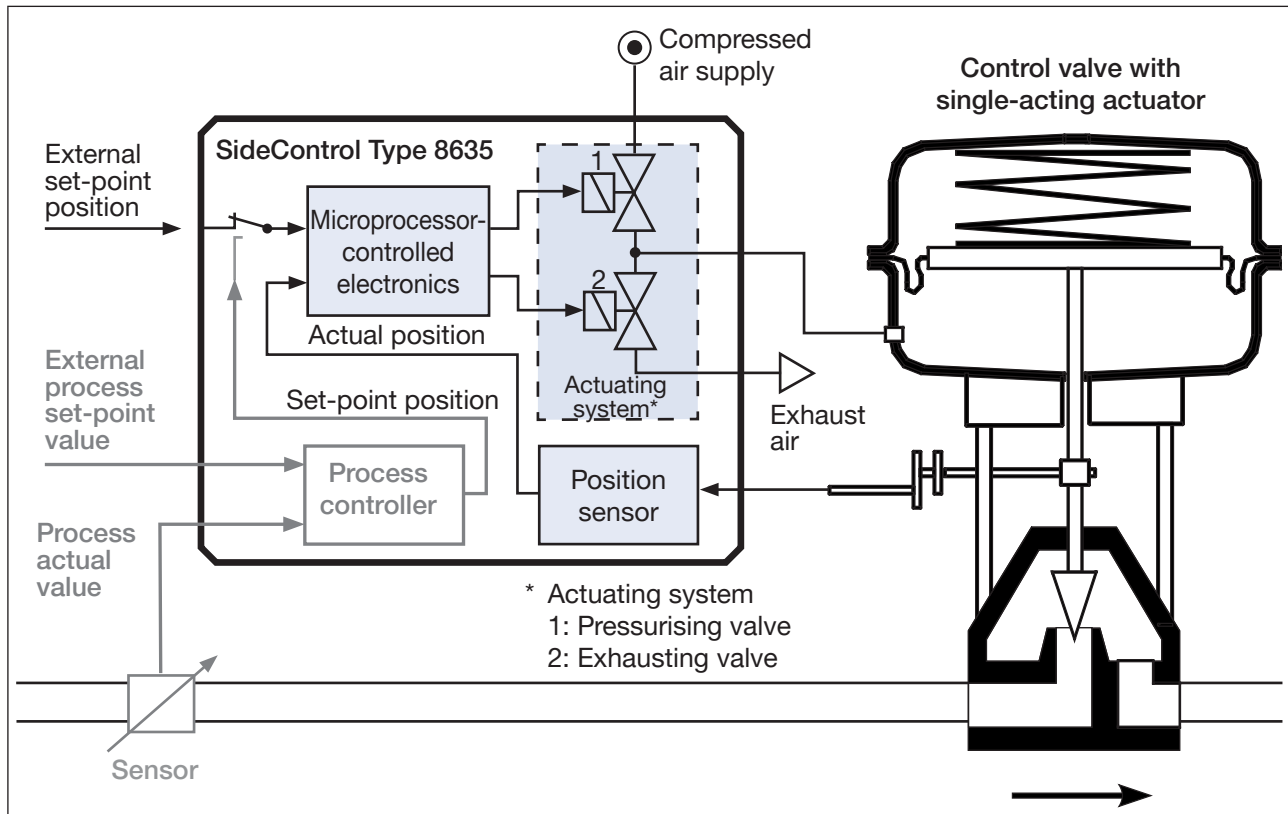

Figure 2: Exemplary presentation of the functionality by means of a functional diagram

Microprocessor-controlled electronics

Signal processing, closed-loop control and actuation of the internal actuating system are carried out via the microprocessor-controlled electronics. The implemented *X.TUNE* software function enables automatic adjustment of the positioner to the control valve used. Set-point value setting default and supply of the electronics takes place via a 4...20 mA standard signal.

Position sensor

The position sensor is a continuous high resolution conductive plastic potentiometer. For attachment to external valves according to NAMUR, a device variant with internal rotary potentiometer is used; for combination with Bürkert valves, a variant with external linear potentiometer is used.



If the SideControl Type 8635 is operated with a Bürkert control valve, the use of an external position sensor is required. The position sensor is mounted on the actuator of the control valve and is connected to the SideControl Type 8635 via a cable.

Actuating system

The actuating system for pressurising and exhausting the actuator chamber consists of 2 piezoelectric pilot valves and 2 pneumatic amplifier stages. Power consumption is very low due to the piezoelectric technology. The actuating system does not work continuously, but is clocked.

5.4 Interfaces

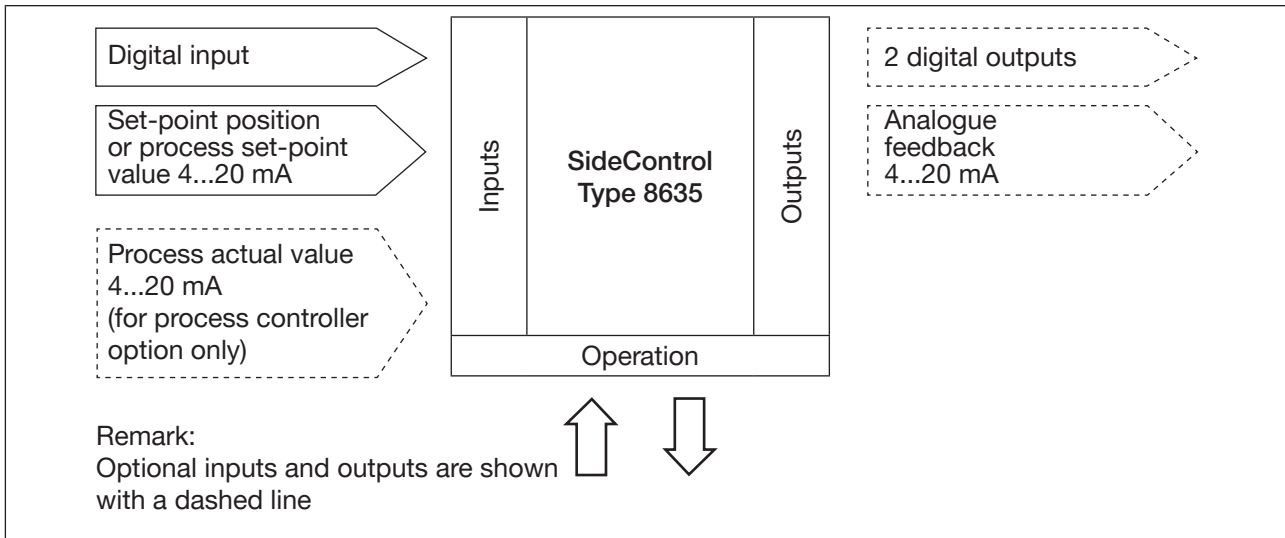

Figure 3: Interfaces of the positioner / process controller



The SideControl Type 8635 is a 2-wire device, i.e. power supply takes place via the set-point signal.

5.5 Operation as positioner

The position sensor records the current position (POS, actual position) of the pneumatic actuator. The positioner compares this actual position with the set-point position (CMD) specified as a standard signal.

If there is a control difference (X_{d1}), the positioner sends a pulse width modulated voltage signal to the actuating system as an actuating variable. With single-acting actuators, the pressurising valve is actuated via output B1 if there is a positive control difference. If the control difference is negative, the exhausting valve is actuated via output E1.

In this way, the position of the actuator is changed up to control difference 0. Z_1 is a disturbance.

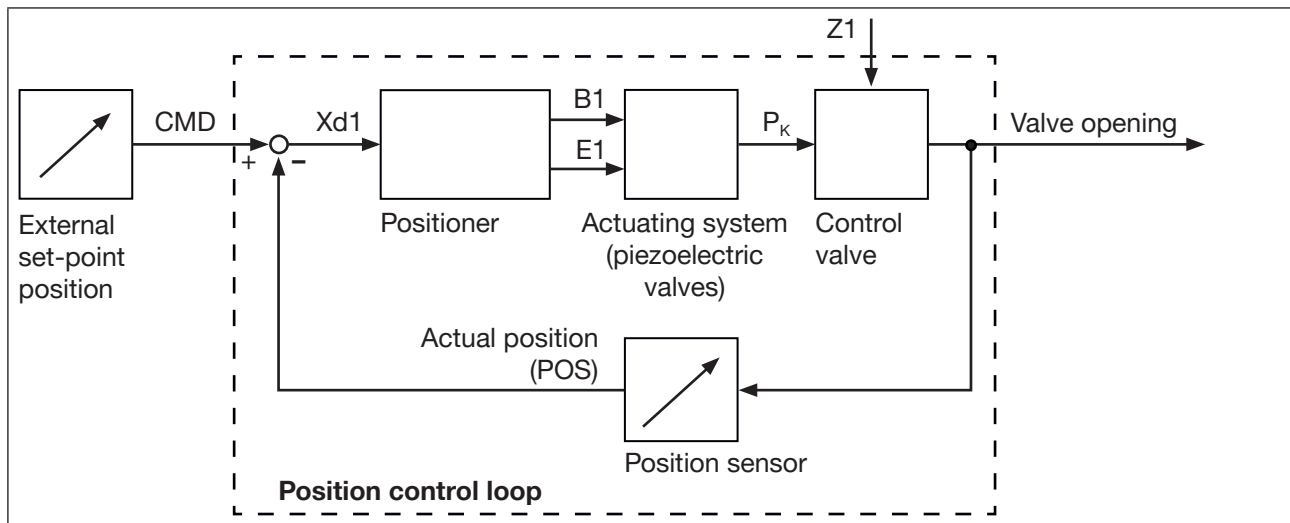

Figure 4: Presentation of the position control loop

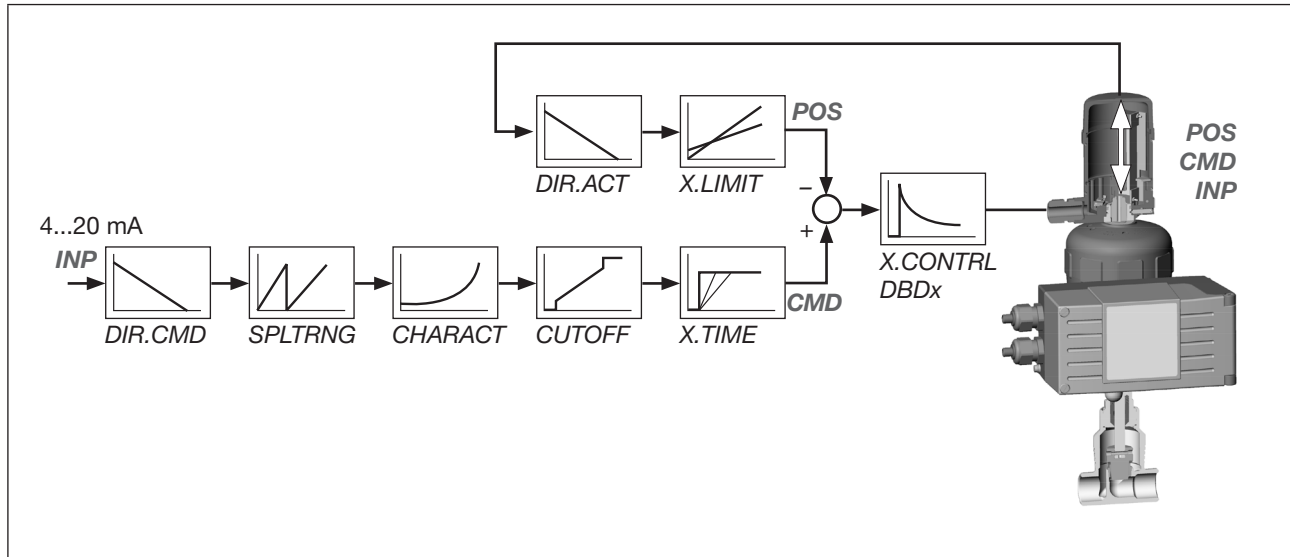

Figure 5: Schematic presentation of the position control

MAN 1000011213 EN Version: L Status: RL (released | freigegeben) printed: 08.05.2026

5.6 Operation as a process controller (option)

If the SideControl Type 8635 is operated as a process controller, the position control becomes a subordinate auxiliary control loop. This results in cascade control.

The process controller (as the main control loop) is implemented in the device as a PID controller. In this case, the process set-point value (SP) is specified as the set-point value and compared with the process actual value (PV). The process actual value is supplied by a sensor.

The actuating variable is formed according to the description of the positioner. Z2 represents a disturbance acting on the process.

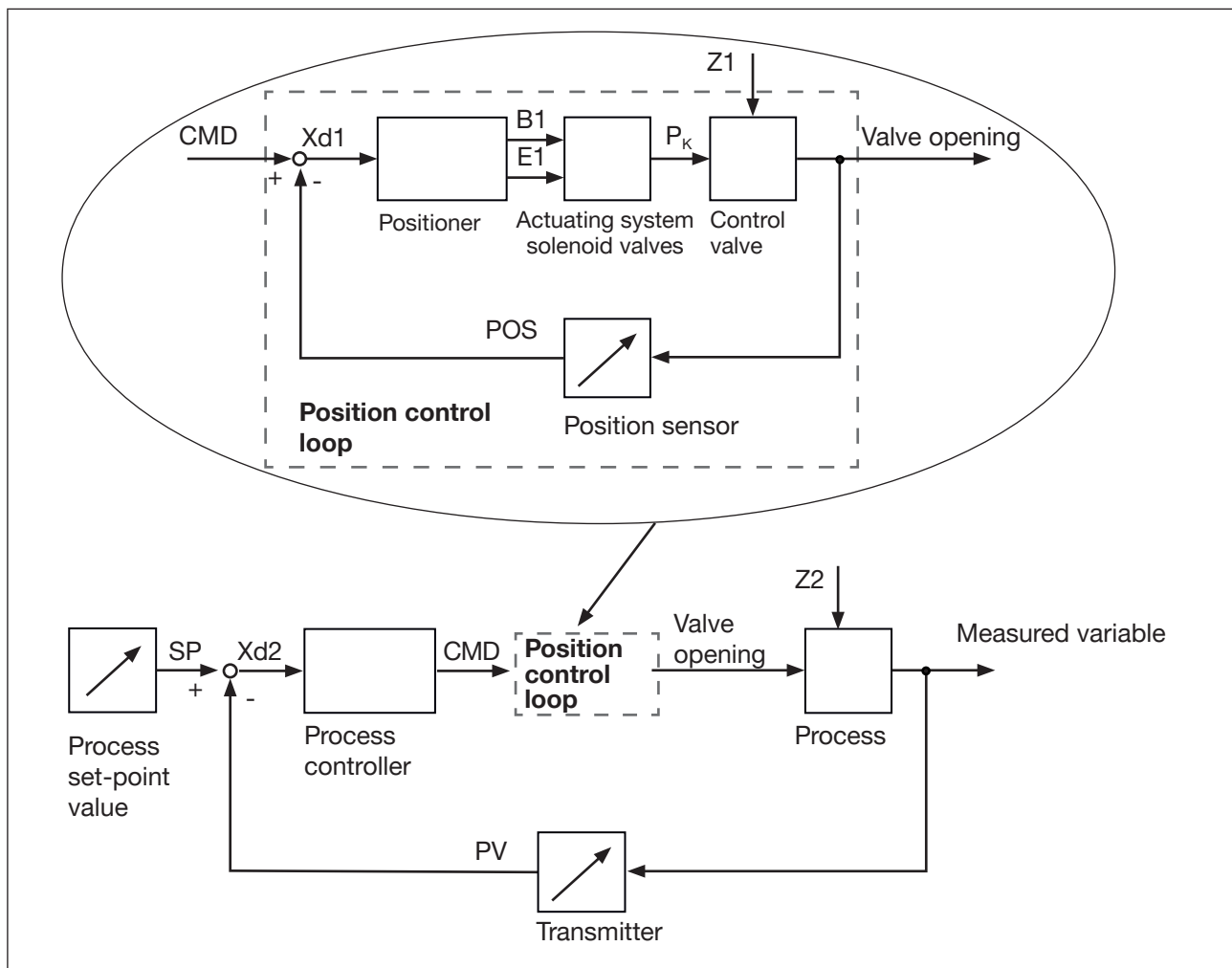

Figure 6: Presentation of the process control loop

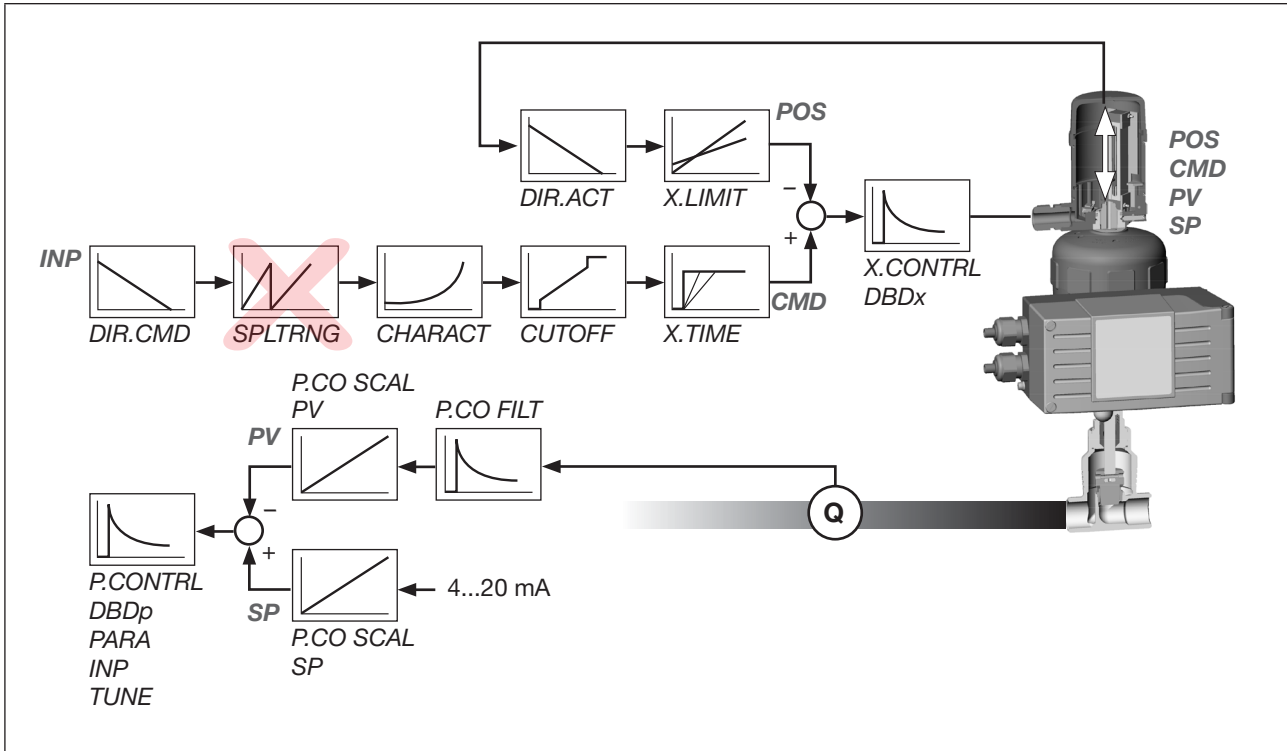

Figure 7: Schematic presentation of the process control

6 TECHNICAL DATA

6.1 Conformity

The device conforms to the EU directives as per the EU Declaration of Conformity (if applicable).

6.2 Standards

The applied standards, which are used to demonstrate conformity with EU directives, are listed in the EU type examination certificate and/or the EU Declaration of Conformity (if applicable).

6.3 Type label

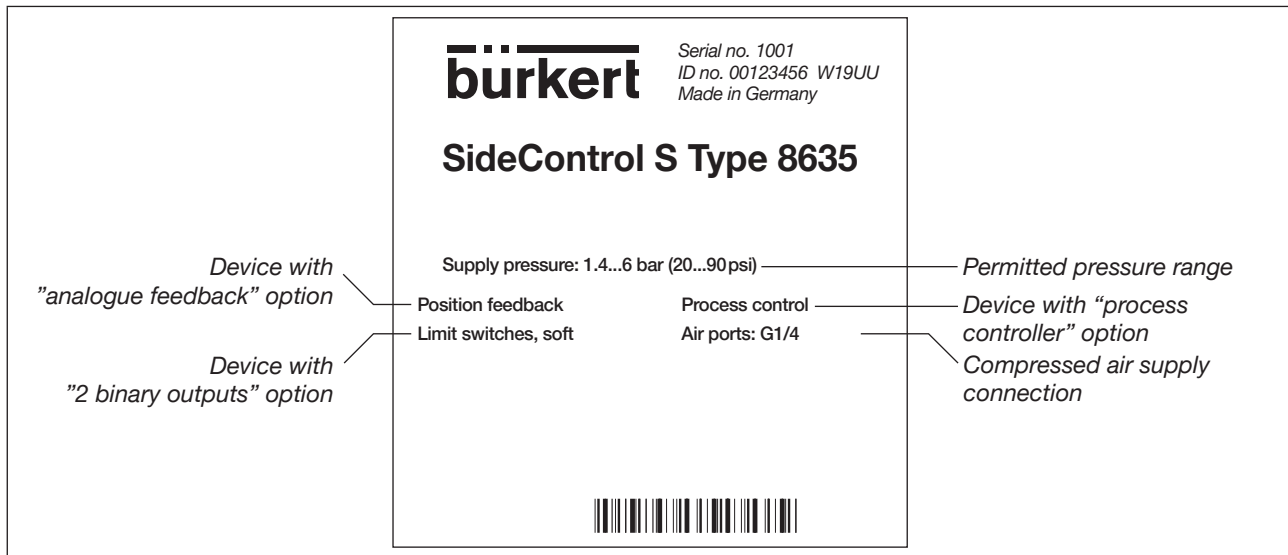

Figure 8: Type label example

6.4 Operating conditions



WARNING

Sunlight or temperature fluctuations may cause malfunctions or leaks.

- ▶ When used outdoors, protect the device against adverse weather conditions.
- ▶ Do not exceed or undercut the permissible ambient temperature.

Permitted ambient temperature	–25...+65 °C (for temperature class T4/T5 or for devices without EEx-ia approval) –25...+60 °C (for temperature class T6) At temperatures below 0 °C, the display may show an extended response time and reduced contrast.
Degree of protection	IP65 acc. to EN 60529 (to achieve a degree of protection of IP65, seal the cable entries tightly)

6.4.1 Fluidic data

Control medium	Neutral gases, air quality classes acc. to DIN ISO 8573-1
Dust content class 7	Max. particle size 40 µm Max. particle density 10 mg/m ³
Water content class 3	Max. pressure dew point –20 °C or min. 10 °C below the lowest operating temperature
Oil content class X	Max. 25 mg/m ³
Temperature range of the compressed air	–25...+65 °C (for temperature class T4/T5 or for devices without EEx-ia approval) –25...+60 °C (for temperature class T6)
Pressure range	1.4...6 bar
Supply pressure fluctuation	Max. ± 10% during operation
Air flow rate of the pilot valve	
at 1.4 bar pressure drop above valve	Approx. 55 l _N /min for pressurising and exhausting
at 6 bar pressure drop above valve	Approx. 170 l _N /min for pressurising and exhausting
Internal air consumption in controlled state	0.0 l _N /min
Throttle screw	Setting ratio approx. 1:10
Ports	G1/4 internal thread

6.4.2 Electrical data

Protection class	III acc. to DIN EN 61140
Connection	2 cable glands (M 20 x 1,5), connection terminals 0.14...1.5 mm ²
Power supply	Via set-point value input 4...20 mA, 2-wire technology
Load voltage	< 10.2 V $\overline{=}$
Load resistance	590 Ω (at 20 mA and 11.8 V $\overline{=}$)
Process actual value input (optional)	4...20 mA
Load voltage	200 mV at 20 mA
Load resistance	10 Ω
Digital input	Mechanical normally open/closed contact
Analogue feedback (optional)	4...20 mA (electrically isolated) This is a passive signal that must be supplied externally.
Supply voltage	$U_{\text{Supply}} = 12...30 \text{ V } \overline{=}$
Load	$U_{\text{Supply}} \geq 12 \text{ V} + R_{\text{Load}} \times 20 \text{ mA}$
	<p style="text-align: center;">Supply voltage depending on the load</p>
2 digital outputs (optional)	Behave like a NAMUR sensor acc. to EN 60947-5-6 (electrically isolated)
Supply voltage	5...11 V $\overline{=}$
Current in switching status OPEN	< 1.2 mA
Current in switching status CLOSE	> 2.1 mA
Effective direction	NO (normally open) or NC (normally closed); parameterisable
Permitted maximum values	See Certificate of Conformity

MAN 1000011213 EN Version: L Status: RL (released | freigegeben) printed: 08.05.2026

6.4.3 Mechanical data

Dimensions	see data sheet
Materials	
Housing	Aluminium, hard anodised and plastic coated
Cable glands	PA + NBR (seals)
Other external parts	Stainless steel V4A
Seal material	NBR (O-rings) CE Neoprene (sponge rubber round cord)
Weight	Approx. 1.5 kg

6.5 Safety end positions after failure of the electrical or pneumatic auxiliary power

Actuator type	Designation	Safety end positions after failure of the	
		electrical auxiliary power	pneumatic auxiliary power
	single-acting Control function A (NC)	down	down
	single-acting Control function B (NO)	up	up

Table 1: Safety end positions

7 DIRECT ATTACHMENT TO BÜRKERT CONTROL VALVES

This variant of the SideControl Type 8635 is only supplied as part of a complete control system (SideControl + position sensor + associated attachments + control valve). The control system is already fully assembled and tested upon delivery.

8 INSTALLATION OF THE REMOTE VARIANT

DANGER

Risk of injury due to high pressure and escaping medium.

- ▶ Before working on the device or system, switch off the pressure. Exhaust or empty the lines.

Risk due to electric shock.

- ▶ Before working on the device or system, switch off the power supply. Secure against reactivation.

WARNING

Risk of injury due to improper installation.

- ▶ Only trained technicians may perform installation work.
- ▶ Perform installation work using suitable tools only.

Risk of injury due to unintentional activation of the system and uncontrolled restart.

- ▶ Secure the system against unintentional activation.
- ▶ Ensure that the system starts up in a controlled manner only.

CAUTION

Risk of injury due to heavy device.

During transportation or installation work, a heavy device may fall down and cause injuries.

- ▶ Transport, install and remove heavy device with the aid of a second person only.
- ▶ Use suitable tools.

8.1 Wall mounting with mounting bracket

The SideControl Type 8635 Remote variant is supplied with a pre-assembled mounting bracket. The mounting bracket can be used for mounting the device on a wall.

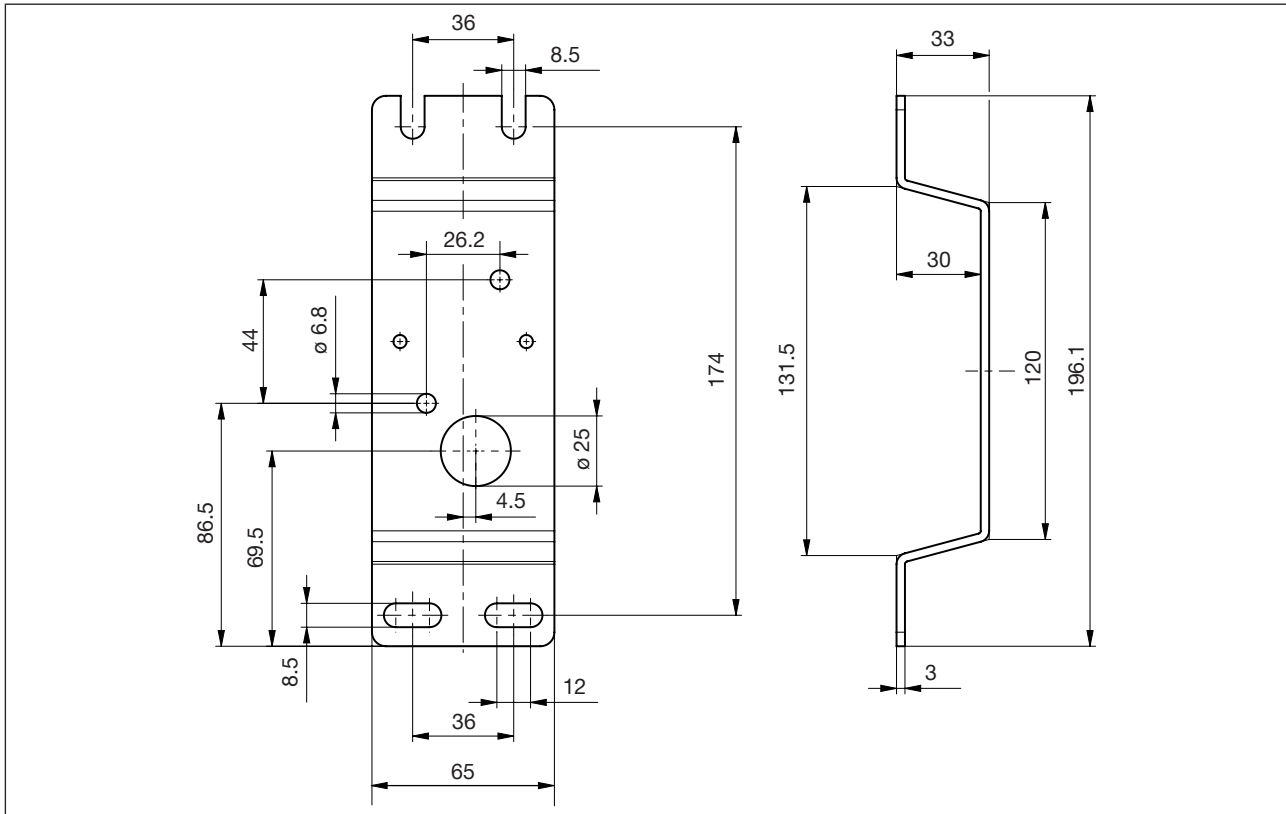

Figure 9: Dimensions of the pre-assembled mounting bracket

8.2 “Position sensor Remote” attachment kit

The Remote variant does not have a position sensor in the form of a rotary position sensor. The device is connected to an external position sensor. With this variant, the connection cable for connecting the device to the position sensor is pre-assembled.

To be able to mount the position sensor on the actuator of the control valve, the attachment kit, which is available as an accessory, must first be mounted on the actuator (see section “23 Accessories” on page 90).

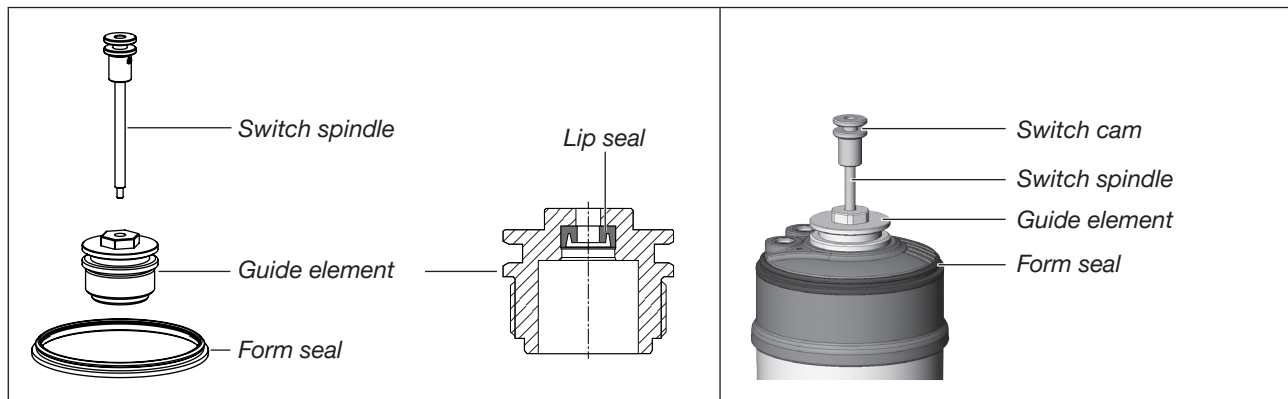

Figure 10: “Position sensor Remote” attachment kit

Actuator with mounted attachment kit

Preparing the control valve:

- Unscrew the transparent cover on the actuator of the control valve and the position indicator (yellow cap) on the spindle extension of the control valve (if fitted).
- For control valves with push-in connectors:
Remove the collets from both pilot air ports (if fitted).

Preparing the attachment kit:

- Push the switch spindle through the guide element.
Please note: Do not damage the lip seal! The lip seal is pre-assembled in the guide element and must be “engaged” in the undercut.
- To secure the switch spindle, apply a small amount of screw locking paint (Loctite 290) to the thread of the switch spindle.

Mounting the attachment kit on the actuator:

- Screw the guide element into the actuator cover.
Make sure that the O-ring is positioned in the actuator cover.
- Tighten the guide element to a torque of 5 Nm.
- Tighten the switch spindle to a torque of 1 Nm.
- Fit the form seal (part of the attachment kit) on the actuator cover, ensuring the smaller diameter points upwards.
- Check the correct position of the O-rings in the pilot air ports.

8.3 Mounting the position sensor on the actuator:

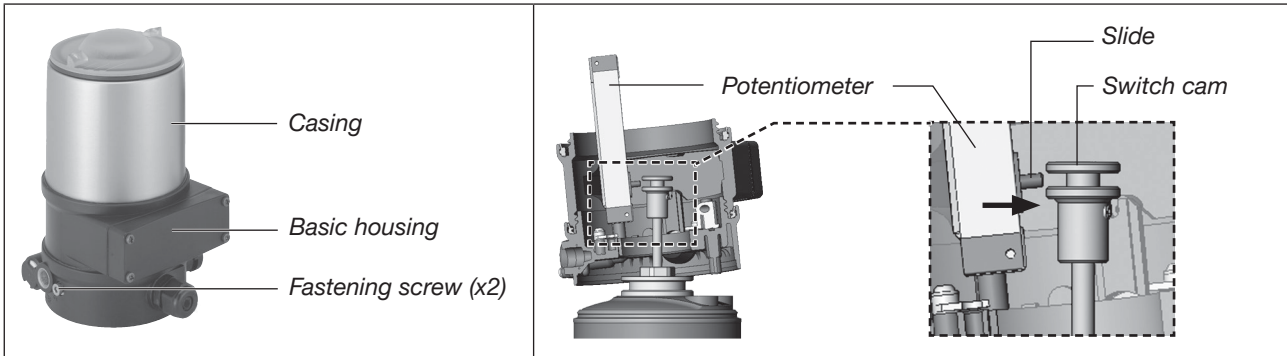

Figure 11: Position sensor Remote

- Unscrew the casing of the position sensor counterclockwise and remove it.
- In the basic housing of the position sensor, push the slide of the potentiometer downwards.
- Ease the basic housing over the switch cam of the valve actuator, while inserting the slide of the potentiometer laterally into the switch cam.
- Align the connection piece of the basic housing with the pilot air ports of the valve actuator (see “Figure 12”).

NOTE!

- ▶ Check:
 - Is the slide of the potentiometer hooked into the switch cam?
 - Are the position sensor connection pieces aligned with the pilot air ports?

- Push the position sensor onto the actuator without rotating it until no gap is visible at the form seal.
- Attach the position sensor to the actuator using the two lateral fastening screws.
Maximum tightening torque 1.5 Nm!



To ensure a degree of protection of IP65/67, do not exceed the maximum tightening torque.

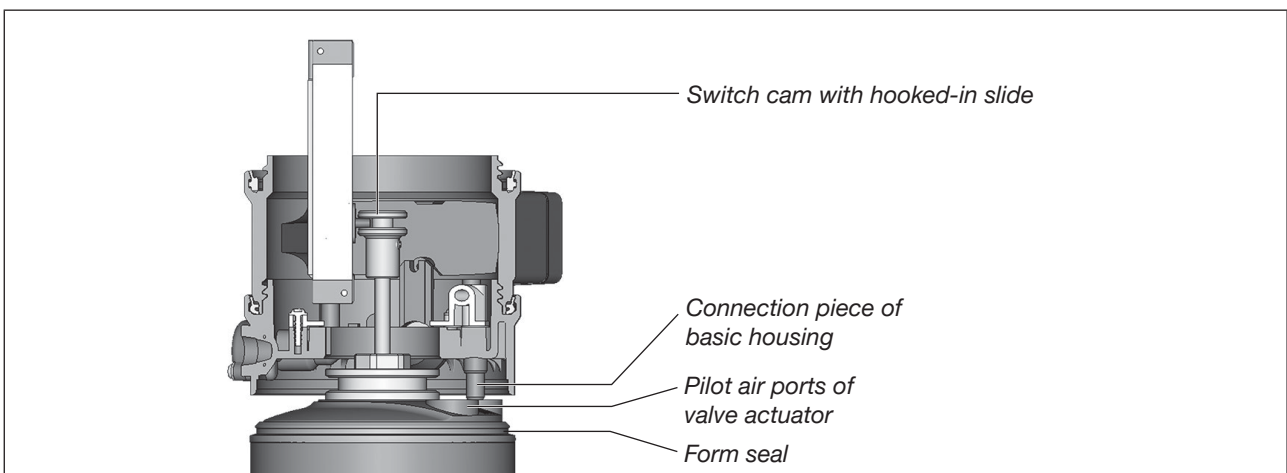

Figure 12: Aligning the position sensor with the actuator

8.4 Connecting the position sensor electrically

DANGER!

Risk due to electric shock.

- ▶ Before working on the device or system, switch off the power supply. Secure against reactivation.

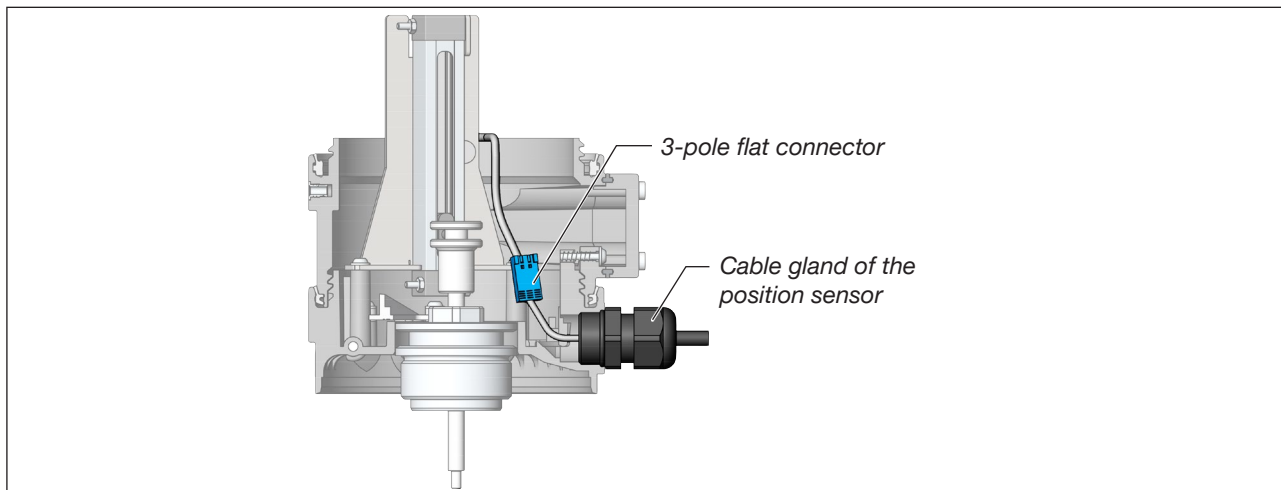

Figure 13: Electrical connection

- Feed the cable pre-assembled on the SideControl Type 8635 with the mounted flat connector through the cable gland of the position sensor.
- Connect the flat connector to its counterpart in the position sensor.
- When tightening the cable gland, pay attention to the position of the plug connection. See marked area in the following “Figure 14”.



The cable in the housing should have the minimum required length but must not be under tension.

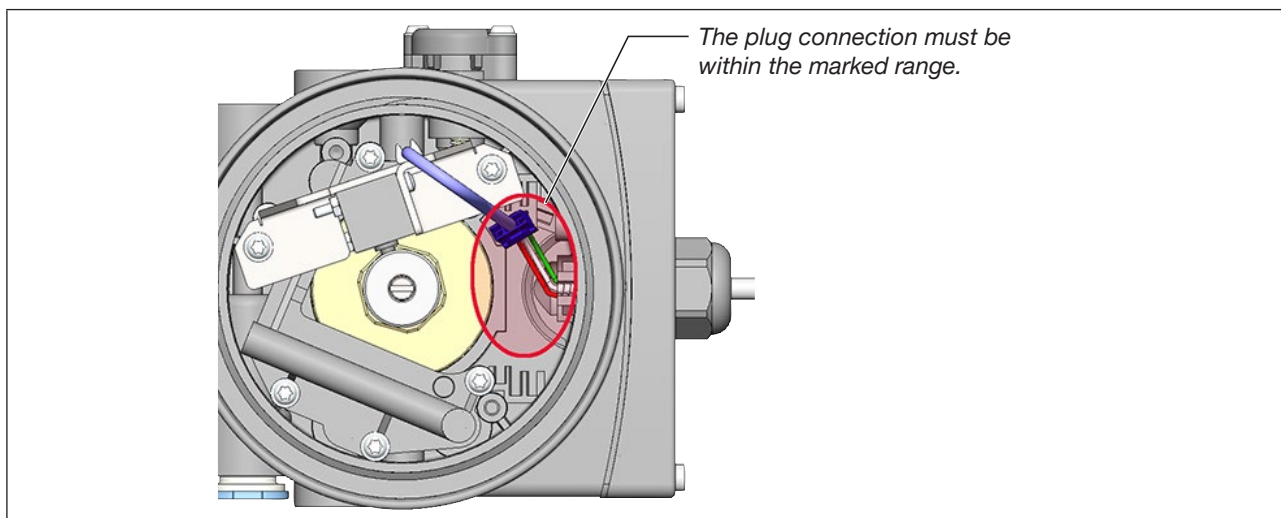

Figure 14: Position of the electrical plug connection in the position sensor

- Push on the casing and screw it in clockwise up to the stop.

8.5 Connecting the position sensor pneumatically

! DANGER!

Risk of injury due to high pressure and escaping medium.

- ▶ Before working on the device or system, switch off the pressure. Exhaust or empty the lines.

! Adjust the length of the pilot air line to the actuator size.

The dead space volume created by the pilot air line can have a negative impact on the control characteristics.

Basically, the smaller the actuator, the more sensitive the control system reacts to the length of the pilot air line.

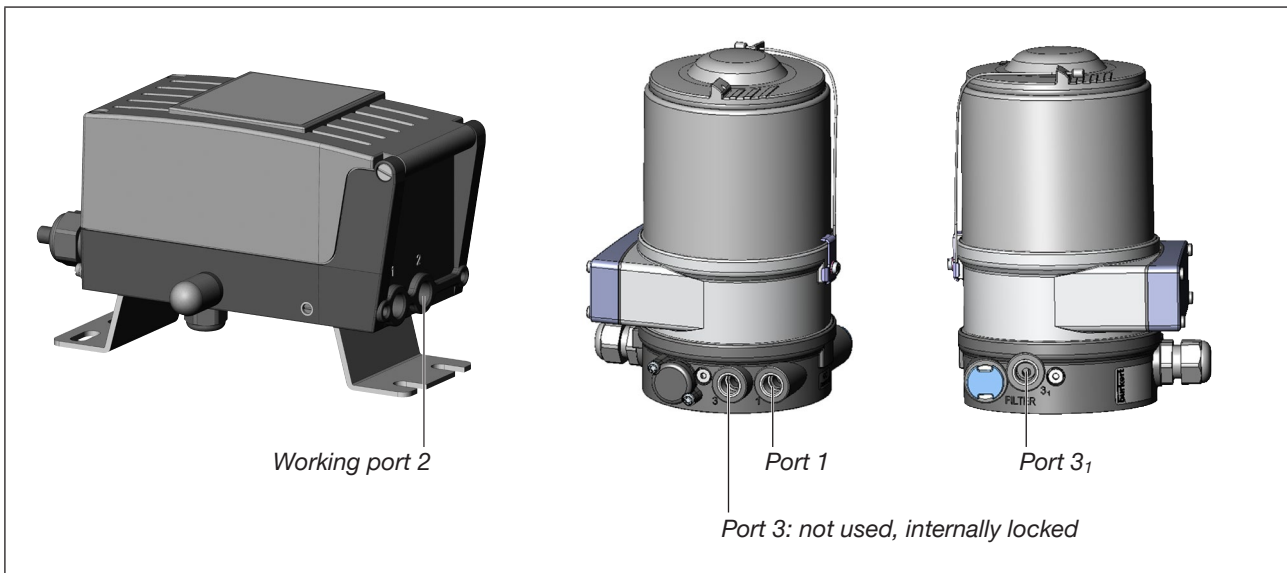

Figure 15: Pneumatic connection

- Connect working port 2 of the SideControl to port 1 of the position sensor using a hose.
- Mount the exhaust air line or the silencer at port 3₁ of the position sensor.

9 DIRECT ATTACHMENT OF THE LINEAR ACTUATOR



DANGER

Risk of injury due to high pressure and escaping medium.

- ▶ Before working on the device or system, switch off the pressure. Exhaust or empty the lines.

Risk due to electric shock.

- ▶ Before working on the device or system, switch off the power supply and secure to prevent reactivation.



WARNING

Risk of injury due to improper installation.

- ▶ Only trained technicians may perform installation work.
- ▶ Perform installation work using suitable tools only.

Risk of injury due to unintentional activation of the system and uncontrolled restart.

- ▶ Secure the system against unintentional activation.
- ▶ Ensure that the system starts up in a controlled manner only.



CAUTION

Risk of injury due to heavy device.

During transportation or installation work, a heavy device may fall down and cause injuries.

- ▶ Transport, install and remove heavy device with the aid of a second person only.
- ▶ Use suitable tools.

9.1 Attachment kit for linear actuators

An attachment kit is required to mount the SideControl on linear actuators according to NAMUR.

The attachment kit is available as an accessory from Bürkert (see section “23 Accessories”).

Seq. no.	Quantity [pieces]	Designation
1	1	NAMUR mounting bracket IEC 534
2	1	Hoop
3	2	Clamping piece
4	1	Driver pin
5	1	Conical roller
6a	1	NAMUR lever for stroke range 3...35 mm
6b	1	NAMUR lever for stroke range 35...130 mm
7	2	U-bolt
8	4	Hexagon bolt DIN 933 M8x20
9	2	Hexagon bolt DIN 933 M8x16
10	6	Spring lock washer DIN 127 A8
11	6	Washer DIN 125 B8.4
12	2	Washer DIN 125 B6.4
13	1	Spring VD-115E 0.70 x 11.3 x 32.7 x 3.5
14	1	Spring washer DIN 137 A6
15	1	Locking washer DIN 6799 - 3.2
16	3	Spring lock washer DIN 127 A6
17	3	Hexagon bolt DIN 933 M6x25
18	1	Hexagon nut DIN 934 M6
19	1	Square nut DIN 557 M6
21	4	Hexagon nut DIN 934 M8
22	1	Guide washer 6.2 x 9.9 x 15 x 3.5

Table 2: Attachment kit for linear actuators

9.2 Mounting the hoop and lever

The valve position is transmitted to the position sensor installed in the SideControl Type 8635 via a lever (according to NAMUR).

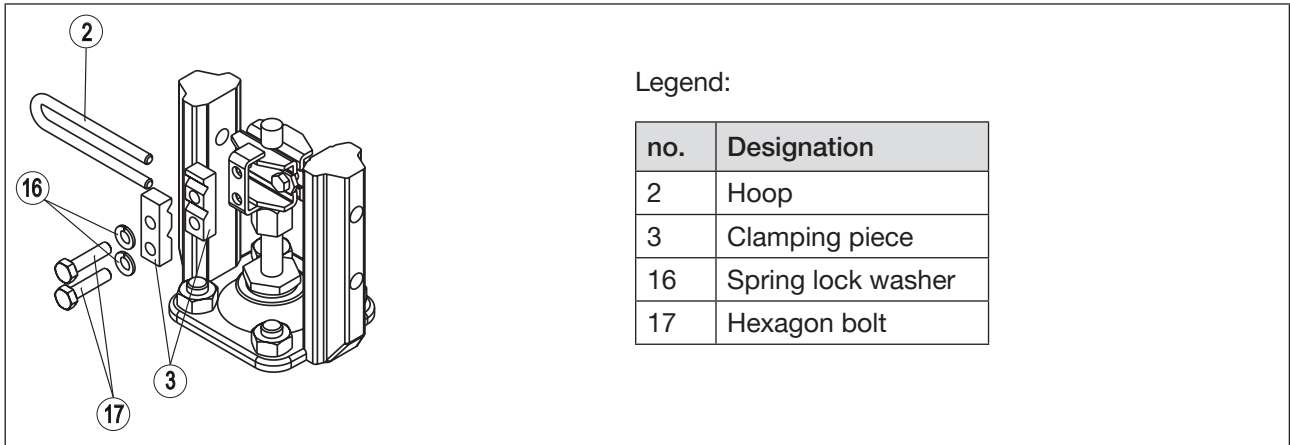

Figure 16: Mounting the hoop

- Mount the hoop ② on the actuator spindle using the clamping pieces ③, the hexagon bolts ⑰ and the spring lock washers ⑯.
- Select the short lever ⑥a or the long lever ⑥b according to the stroke of the actuator.
- Assemble the lever, if not pre-assembled (see “Figure 17”).

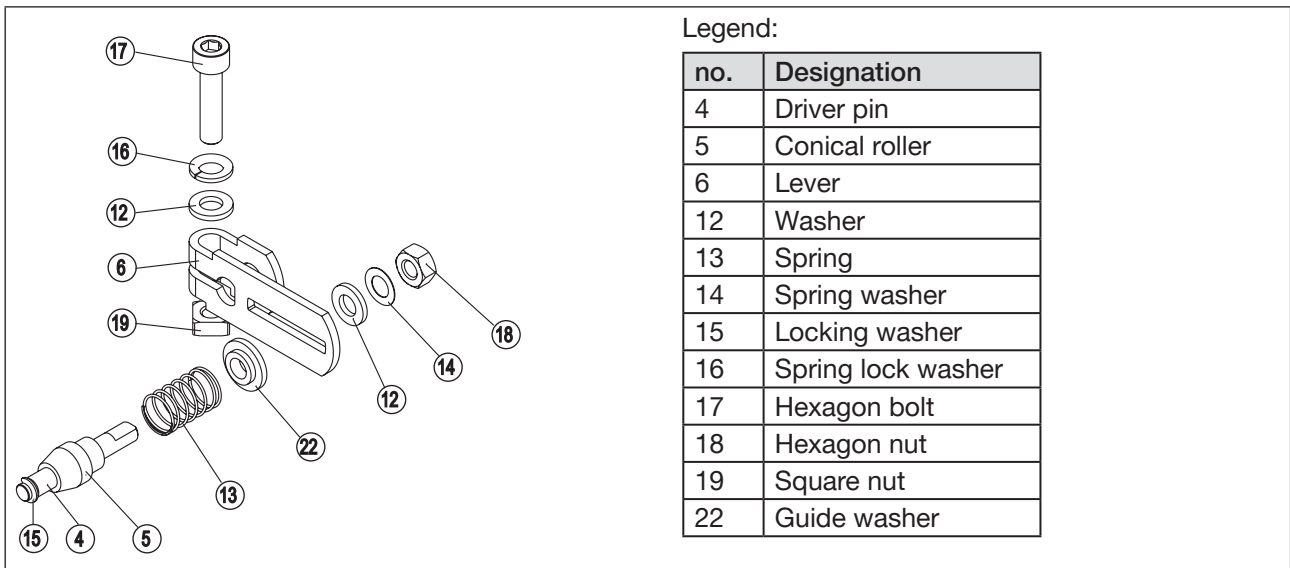

Figure 17: Mounting the lever



The gap between the driver pin and the shaft should be the same as the actuator stroke. As a result, the lever has an ideal rotational range of 60°. This ensures that the position sensor operates at a good resolution.

Angular range of the position sensor:

The maximum angular range of the position sensor is 120°.

Rotational range of the lever:

Minimum 30°

Ideal 60°

Maximum 120° (within the angular range of the position sensor)

The scale printed on the lever is not relevant.

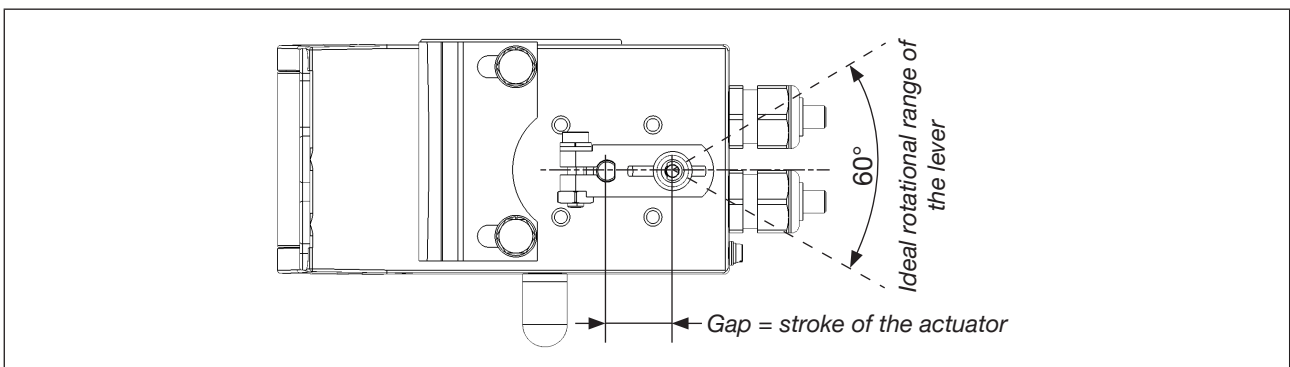

Figure 18: Rotational range of the lever

→ Push the lever onto the shaft of the SideControl Type 8635 and screw it tight.

9.3 Attaching the mounting bracket

→ Attach the mounting bracket ① to the rear of the SideControl Type 8635 using the hexagon bolts ⑨, the spring lock washers ⑩ and the washers ⑪ (see “Figure 19”).



Selection of the M8 thread used on the SideControl Type 8635 depends on the actuator size.

→ To determine the correct position, hold the SideControl Type 8635 with the mounting bracket on the actuator.

The conical roller on the lever of the position sensor must be able to move freely in the hoop along the entire stroke range of the actuator.

At 50% stroke, the lever position should be approximately horizontal (observe section “9.4!”).

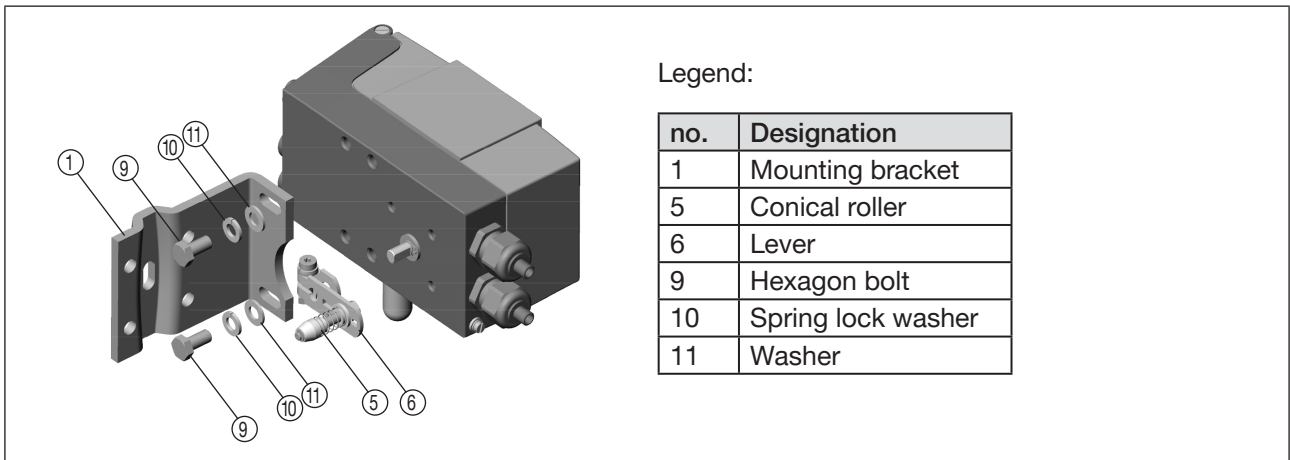

Figure 19: Attaching the mounting bracket to the SideControl Type 8635

For actuators with a cast frame:

→ Attach the mounting bracket to the cast frame using one or more hexagon bolts (8), the washers (11) and the spring lock washers (10) (see “Figure 20”).

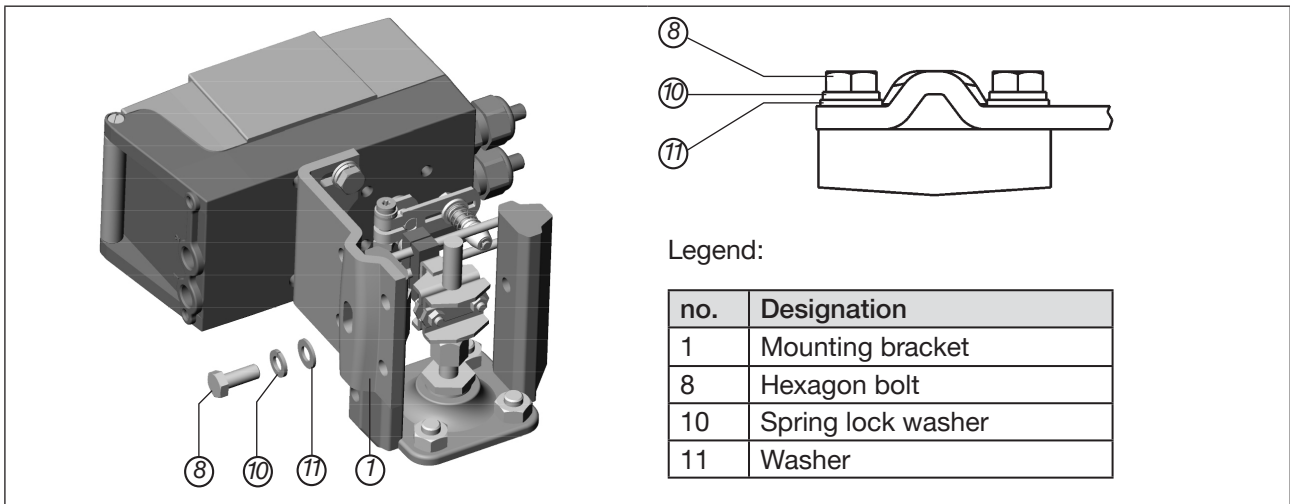

Figure 20: Attaching the positioner with the mounting bracket; for actuators with a cast frame

For actuators with a columnar yoke:

→ Attach the mounting bracket to the columnar yoke using the U-bolt (7), the washers (11), the spring lock washers (10) and the hexagon nuts (21) (see “Figure 21”).

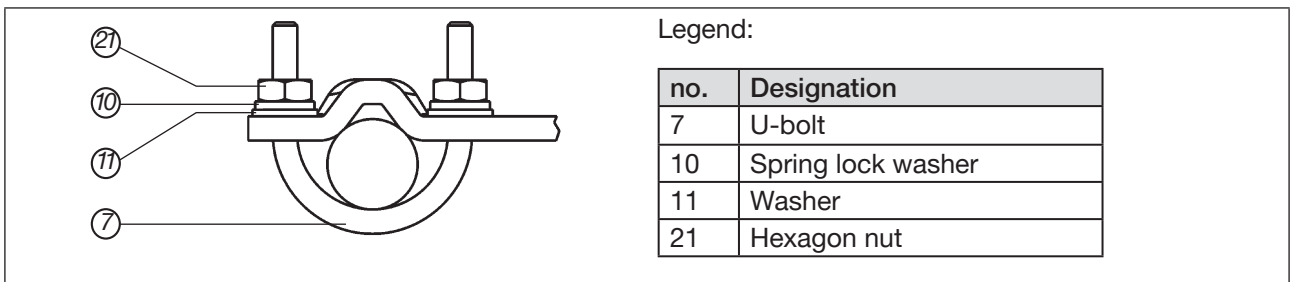

Figure 21: Attaching the positioner with the mounting bracket; for actuators with a columnar yoke

MAN 1000011213 EN Version: L Status: RL (released | freigegeben) printed: 08.05.2026

9.4 Aligning the lever mechanism



The lever mechanism cannot be correctly aligned until the device has been electrically and pneumatically connected.

- Move the actuator in MANUAL operating state to half stroke (according to the scale on the actuator).
- Adjust the height of the SideControl Type 8635 until the lever is horizontal.
- Fix the SideControl Type 8635 in this position on the actuator.

10 DIRECT ATTACHMENT TO THE ROTARY ACTUATOR

! DANGER

Risk of injury due to high pressure and escaping medium.

- ▶ Before working on the device or system, switch off the pressure. Exhaust or empty the lines.

Risk due to electric shock.

- ▶ Before working on the device or system, switch off the power supply. Secure against reactivation.

! WARNING

Risk of injury due to improper installation.

- ▶ Only trained technicians may perform installation work.
- ▶ Perform installation work using suitable tools only.

Risk of injury due to unintentional activation of the system and uncontrolled restart.

- ▶ Secure the system against unintentional activation.
- ▶ Ensure that the system starts up in a controlled manner only.

! CAUTION

Risk of injury due to heavy device.

During transportation or installation work, a heavy device may fall down and cause injuries.

- ▶ Transport, install and remove heavy device with the aid of a second person only.
- ▶ Use suitable tools.

10.1 Attachment kit for rotary actuators

The following accessories are required for mounting the SideControl on rotary actuators according to NAMUR:

- Attachment kit (order no. 787338)
- Assembly bridge (order no. 770294)

Both are available as an accessory from Bürkert (see also section “23 Accessories”).

Attachment kit for rotary actuators

Seq. no.	Quantity [pieces]	Designation
1	1	Adapter
2	2	Setscrew DIN 913 M4 x 10
3	4	Hexagon bolt DIN 933 M6 x 12
4	4	Spring lock washer B6
5	2	Hexagon nut M4

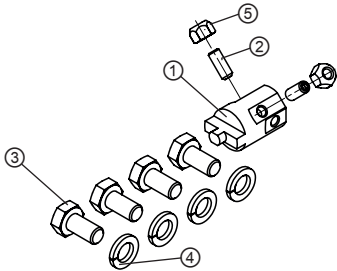

Table 3: Attachment kit for rotary actuators

MAN 1000011213 EN Version: L Status: RL (released | freigegeben) printed: 08.05.2026

10.2 Mounting the SideControl on the rotary actuator

The shaft of the position sensor integrated in the SideControl Type 8635 is connected to the shaft of the rotary actuator using the adapter.

Prior to mounting

- Specify the attachment position of the SideControl Type 8635:
 - parallel to the actuator or
 - rotated by 90° to the actuator
- Determine the home position and the direction of rotation of the actuator.
- Align the flat side of the shaft to the rotational range (see "Figure 22").

! The maximum rotational range is 120°.

Installation

- Connect the adapter ① to the shaft of the SideControl and attach it using the two setscrews ② and the hexagon nuts ⑤ .

! **Anti-twist safeguard:**
One of the setscrews must be situated on the flat side of the shaft.

- Assemble the assembly bridge suitable for the actuator. The assembly bridge consists of 4 parts, which can be adjusted to the actuator by varying the arrangement.
- Attach the assembly bridge to the SideControl using the 4 hexagon bolts ③ and the spring lock washers ④ (see "Figure 23").
- Place the SideControl with the assembly bridge on the rotary actuator and attach it using 4 hexagon bolts ⑥ (see "Figure 24").

! If the message **X.ERR 5** appears on the LC display after starting the X.TUNE function, the alignment of the SideControl shaft with the actuator shaft is incorrect.

- ▶ Check the alignment.
- ▶ Repeat the X.TUNE function.

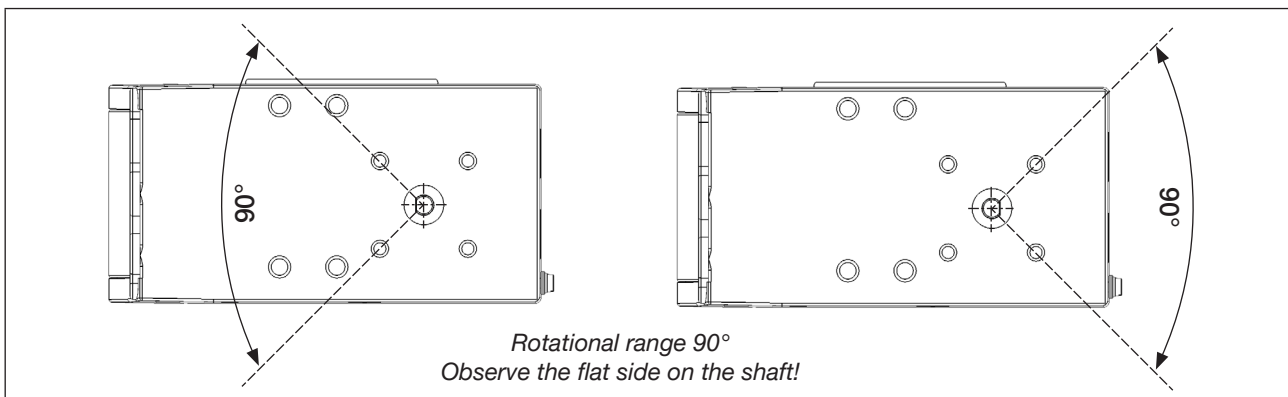

Figure 22: Rotational range

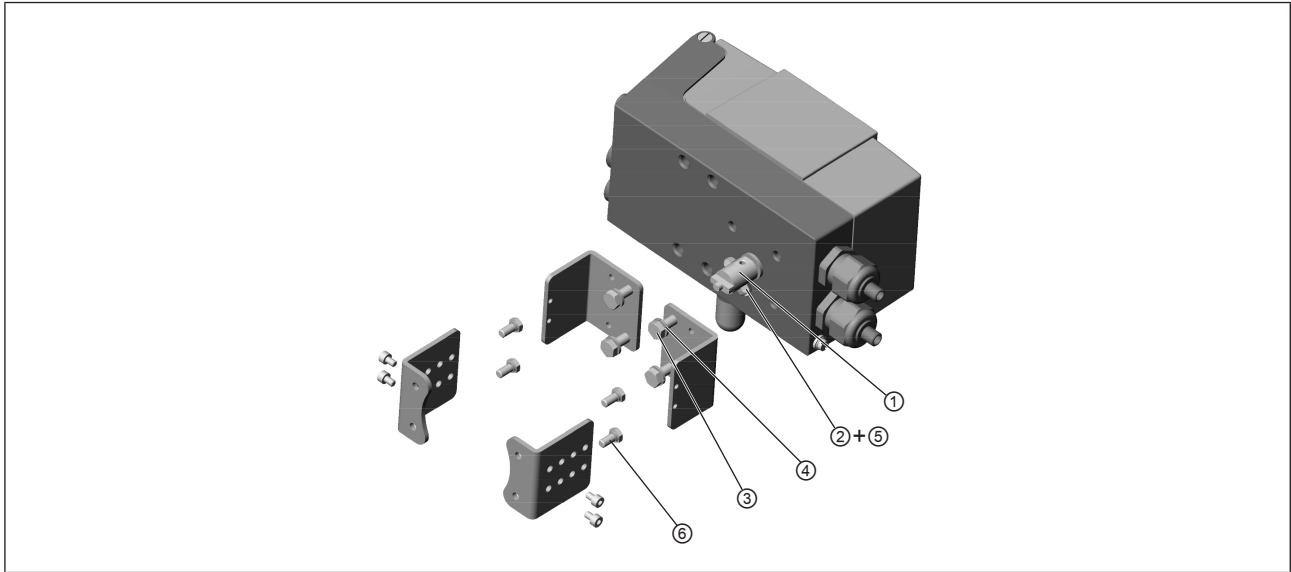

Figure 23: Attaching the assembly bridge

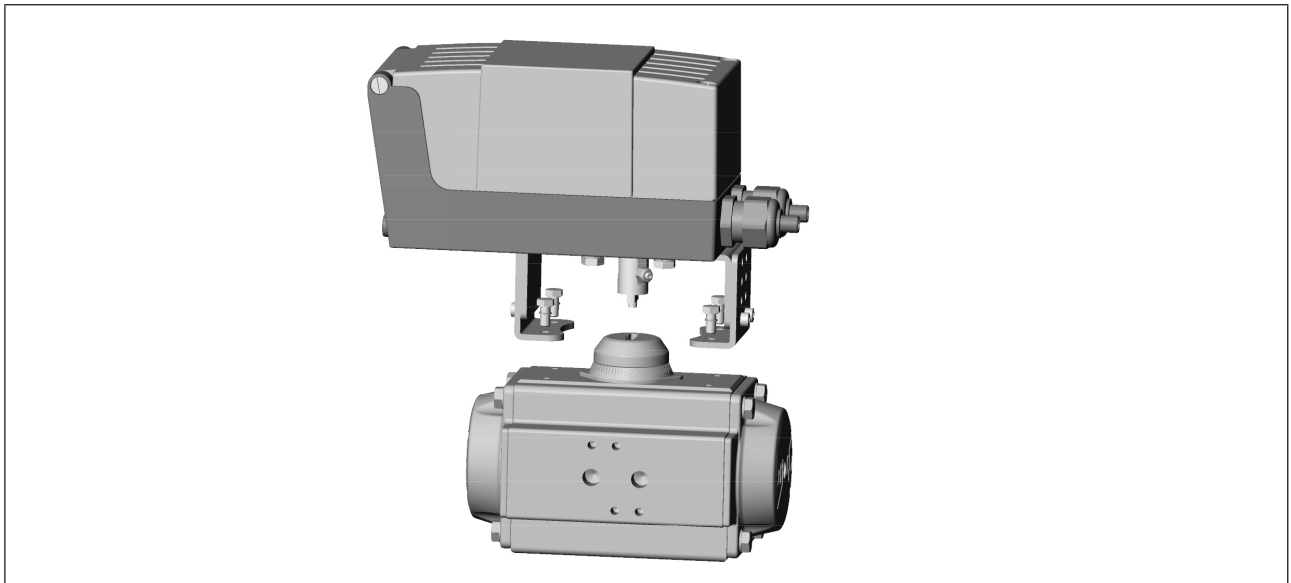

Figure 24: Mounting the SideControl on the rotary actuator

11 PNEUMATIC CONNECTION



DANGER

Risk of injury due to high pressure and escaping medium.

- ▶ Before working on the device or system, switch off the pressure. Exhaust or empty the lines.



WARNING

Risk of injury due to improper installation.

- ▶ Installation may be carried out by authorised technicians only and with the appropriate tools.

Risk of injury due to unintentional activation of the system and uncontrolled restart.

- ▶ Secure the system against unintentional activation.
- ▶ Following installation, ensure a controlled restart.

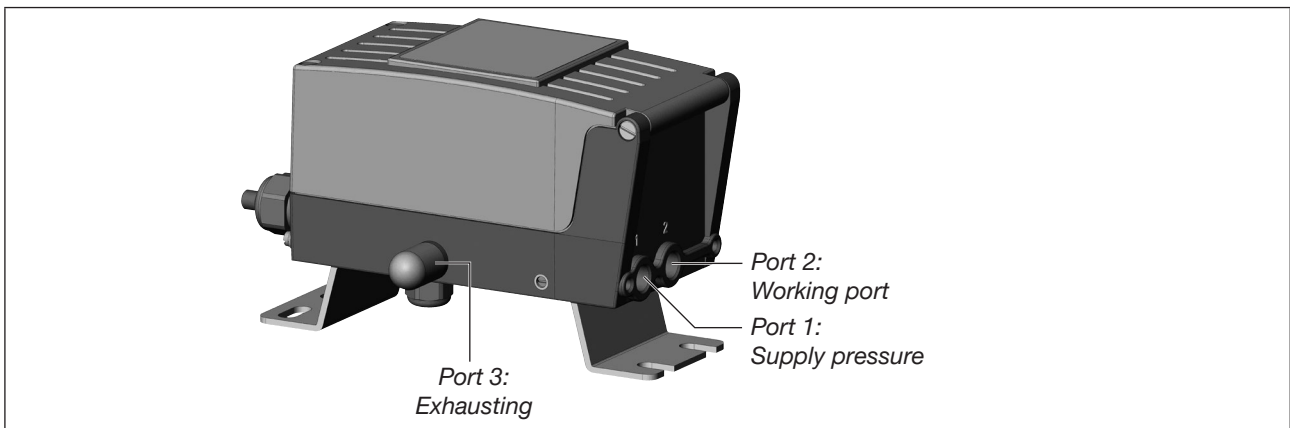

Figure 25: Position of the pneumatic ports

- Apply supply pressure (1.4...6 bar) to port 1.
- Connect port 2 to the single-acting actuator chamber.
- If possible, connect a silencer or similar to port 3. If the port is left open, there is a risk of splash water entering the device.



Important information for perfect control behaviour.

The applied supply pressure must be 0.5...1 bar higher than the minimum control pressure specified on the control valve. This prevents an excessively low pressure difference from having a strong negative impact on the control behaviour in the upper stroke range.

Keep supply pressure fluctuations low during operation (max. $\pm 10\%$). The control parameters calibrated with the X.TUNE function are not ideal for stronger fluctuations.

12 ELECTRICAL CONNECTION



DANGER

Risk of injury due to electric shock.

- ▶ Before working on the device or system, switch off the power supply. Secure against reactivation.
- ▶ Observe the applicable accident prevention and safety regulations for electrical devices.



WARNING

Risk of injury due to improper installation.

- ▶ Installation may be carried out by authorised technicians only and with the appropriate tools.

Risk of injury due to unintentional activation of the system and uncontrolled restart.

- ▶ Secure the system against unintentional activation.
- ▶ Following installation, ensure a controlled restart.



Using the 4...20 mA set-point value input

If several devices are connected in series and the power supply to a device in this series connection fails, the input of the failed device becomes highly resistive. As a result, the 4...20 mA standard signal fails. In this case, please contact Bürkert Service directly.

The connection terminals are located under the housing lid of the SideControl.

→ To open the housing lid, loosen the 2 screws and open the housing lid.

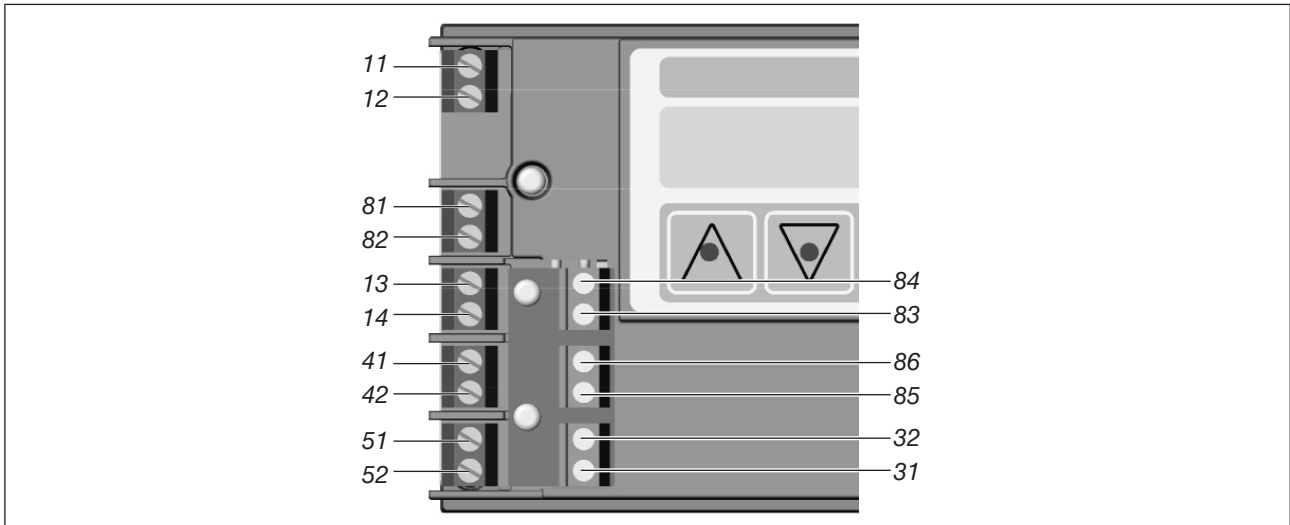

Figure 26: SideControl Type 8635 connection terminals

Description of terminal	Assignment	External circuit
11 + 12 -	Set-point value + Set-point value -	4...20 mA standard signal GND
13 + 14 -	Process actual value + (option) Process actual value - (option)	4...20 mA standard signal GND
31 32	Actual value output + (option) Actual value output - (option)	
41 + 42 -	Proximity switch 1 + (option) Proximity switch 1 - (option)	
51 + 52 -	Proximity switch 2 + (option) Proximity switch 2 - (option)	
81 + 82 -	Digital input + Digital input -	
83 + 84 -	Digital output 1 + (option) Digital output 1 - (option)	
85 + 86 -	Digital output 2 + (option) Digital output 2 - (option)	

Table 4: SideControl Type 8635 connection terminal assignment



! Terminals 31+32 and 83–86:
Passive outputs that must be supplied externally.
The digital outputs behave like a NAMUR sensor acc. to EN 60947-5-6.

13 OPERATING AND DISPLAY ELEMENTS

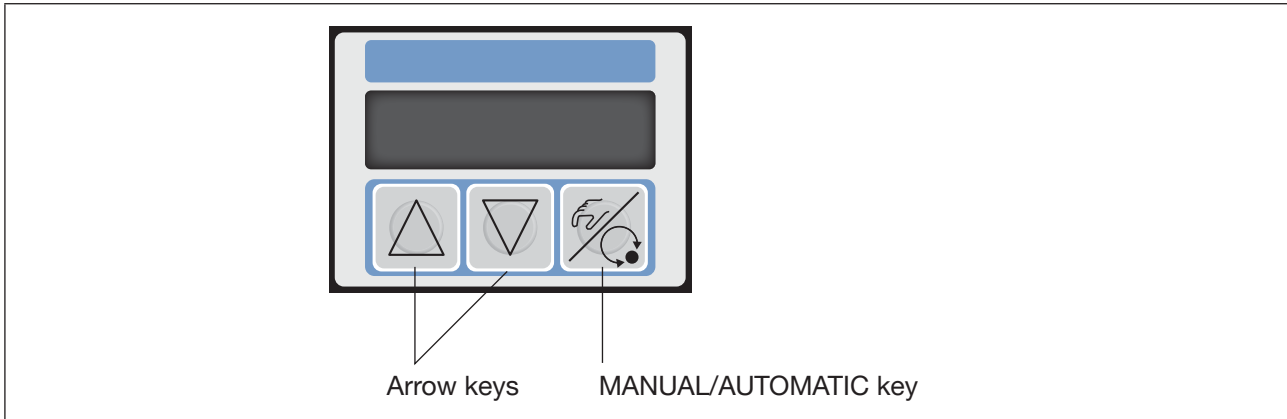
The positioner is parameterised and operated via a display with plain text display and 3 operation keys. The operating elements are located under the housing lid. Process values such as set-point value and actual value are also shown on the display.



13.1 Assignment of the keys

	MANUAL/AUTOMATIC key	<p>At process level: Toggling between the MANUAL and AUTOMATIC operating states</p> <p>At setting level: Toggling between the main menu and the additional menu</p>
	Arrow keys	Toggling between equal menu options, e.g. <i>ADDFUNCT</i> - <i>X.TUNE</i>

14 OPERATING LEVELS

Operating level	Description
Process level	The process level is active after switching on the device. At this level, it is toggled between the MANUAL and AUTOMATIC operating states.
Setting level	<p>This level contains the main menu with the basic functions. Auxiliary functions can be enabled via the <i>ADDFUNCT</i> basic function. If auxiliary functions are enabled, they appear in the main menu and can be configured there.</p> <p>A firmly established basic function is the X.TUNE function. When executing this basic function, the SideControl Type 8635 automatically determines the optimum settings for the valve used and the current operating conditions (supply pressure).</p> <div style="background-color: #f0f0f0; padding: 5px; border: 1px solid #ccc;"> <p> At setting level, the control valve remains in the last controlled position.</p> </div>

Table 5: Operating levels of the software

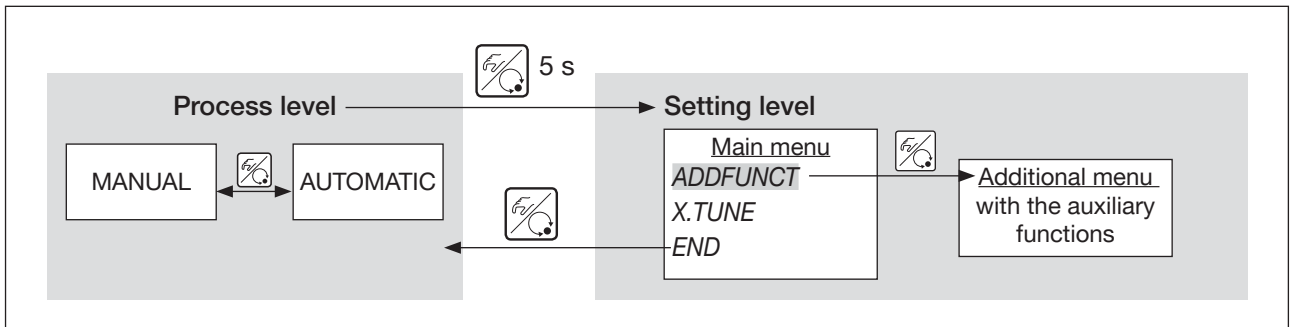



Figure 27: Toggling between the operating levels

15 OPERATING STATES

Operating state	Description
MANUAL	Manual opening or closing of the control valve.
AUTOMATIC	Executing and monitoring automatic position control (or process control with process controller option).

15.1 Changing the operating state

 press briefly	Changing between MANUAL and AUTOMATIC operating state. Only possible at process level.
 press for 5 s	In both MANUAL and AUTOMATIC operating state: Change to setting level.





15.2 Detecting the operating state

Operating state	Display
AUTOMATIC	An apostrophe (') runs continuously from left to right.
MANUAL	–

16 AUTOMATIC OPERATING STATE DURING POSITION CONTROL

Normal controlled operation is executed and monitored in AUTOMATIC operating state.

16.1 Meaning of the keys

 or 	Toggling the display
 or  > 3s	Changing the set-point position (with configured <i>P.CONTRL</i> / <i>P.CO SETP</i> / <i>SETP INT</i> auxiliary function and set display <i>SP</i>)

16.2 Displays in AUTOMATIC operating state:

By pressing the arrow keys you can toggle between 3 display variants.
The following 3 display variants are possible:

- Actual position of the valve actuator POS_XXX (0...100%)
- Set-point position of the valve actuator after
 rescaling by possibly enabled split-range
 function or correction characteristic CMD_XXX (0...100%)
- Input signal for set-point position INP_XXX (4...20 mA)

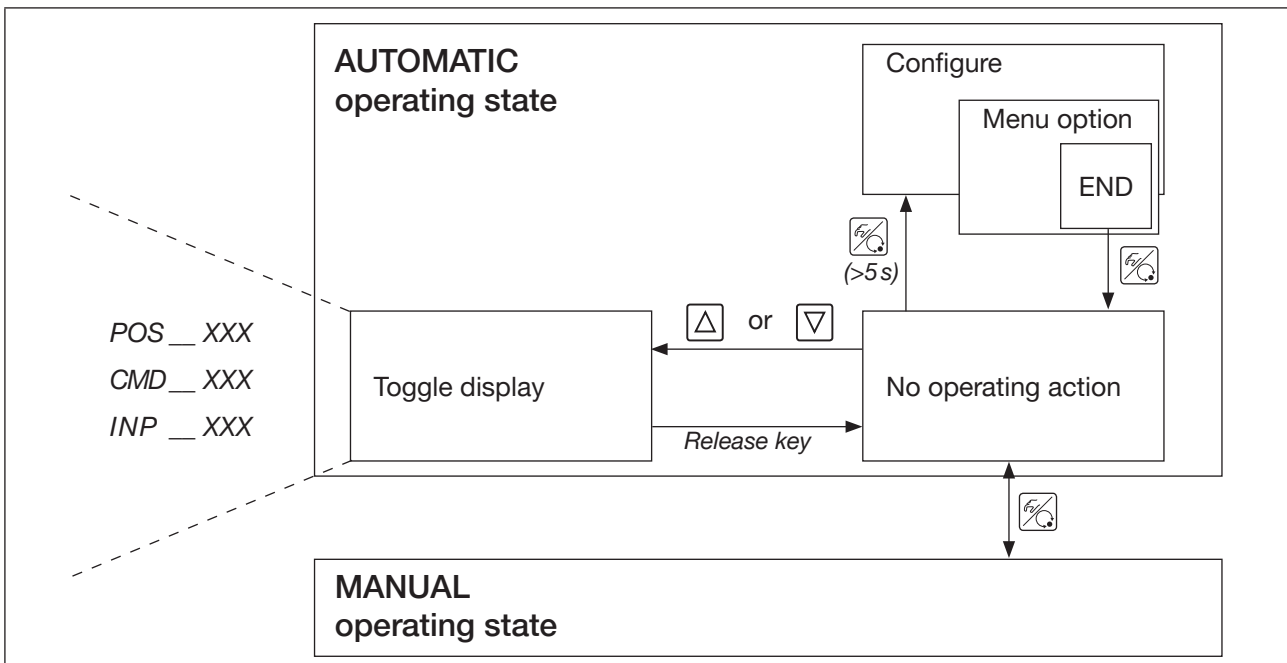

! If the device is in the safety position (for the corresponding configuration, see “19.14 BIN-IN: Setting the function of the digital input” on page 71), *SAFE XXX* appears on the display.
If the *CUTOFF* auxiliary function has been enabled and the process valve is in the sealing area, a flashing *MIN* or *MAX* symbol appears on the display.

17 AUTOMATIC OPERATING STATE DURING PROCESS CONTROL

Normal controlled operation is executed and monitored in AUTOMATIC operating state.

17.1 Meaning of the keys

or	Toggle the display
or > 3s	Changing the process set-point value (with configured <i>P.CONTRL / P.CO SETP / SETP INT</i> auxiliary function and set display <i>SP</i>)
and	making P.TUNE (process tune) ready to start (with PID self-optimisation enabled) <i>P.CONTRL / P.CO TUNE / P.TUN ACT</i>

17.2 Displays in AUTOMATIC operating state:

By pressing the arrow keys you can toggle between 4 display variants.
The following 4 display variants are possible:

- Process actual value *PV*____ (–999...9999)
- Process set-point value *SP*____ (–999...9999)
- Actual position of the valve actuator *POS*_XXX (0...100 %)
- Set-point position of the valve actuator after rescaling or correction characteristic *CMD*_XXX (0...100%)

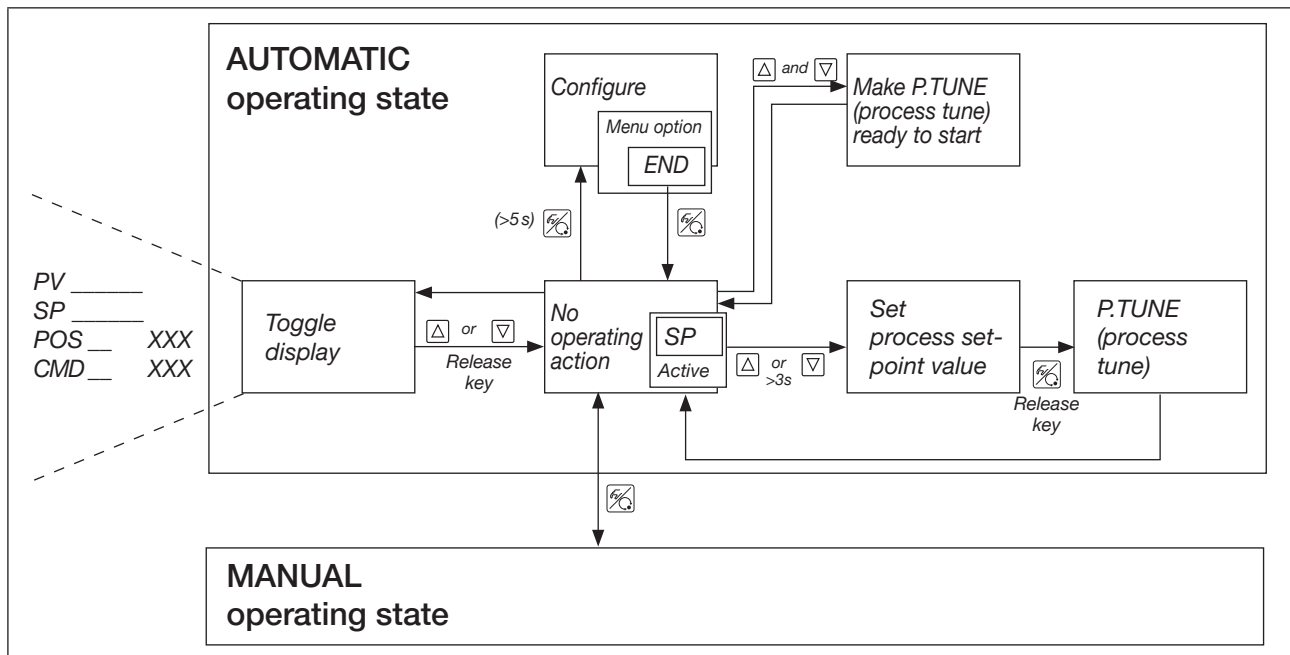



If the device is in the safety position (for the corresponding configuration, see [“19.13 SIG-ERR Configuring the signal error detection”](#) on page 70 or [“19.14 BIN-IN: Setting the function of the digital input”](#) on page 71), *SAFE XXX* appears on the display.

If the *CUTOFF* auxiliary function has been enabled and the process valve is in the sealing area, a flashing *MIN* or *MAX* symbol appears on the display.

If the measuring range of the process actual value is exceeded or undercut, a flashing bar appears on the display.

18 BASIC FUNCTIONS AND AUXILIARY FUNCTIONS

The operating concept for the SideControl Type 8635 is based on a strict separation between basic functions and auxiliary functions. Only the basic functions are enabled when the device is delivered. They are sufficient for normal operation.



Auxiliary functions can be enabled for more demanding control tasks. If auxiliary functions are enabled, they become part of the main menu and can be parameterised there.

18.1 Main menu with the basic functions

Function/Menu	Description
<i>ADDFUNCT</i>	Contains the auxiliary functions. The auxiliary functions are enabled or disabled in this menu. The auxiliary functions can be accessed by pressing the MANUAL/AUTOMATIC key.
<i>X.TUNE</i>	AUTOTUNE or manual TUNE This function adjusts the position control to the physical stroke of the control valve.
<i>END</i>	Completing the configuration, returning to process level.

Table 6: Basic functions of the SideControl Type 8635

18.2 Function of the keys in the main menu and ADDFUNCT

Key	in the menu	in a selected and confirmed menu option
	Scroll up (selection)	Incrementing (increasing) numerical values
	Scroll down (selection)	Decrementing (reducing) numerical values

Key	in the menu	in the <i>ADDFUNCT</i> menu
	Confirming the selected menu option	Confirming the additional menu option selected to include it in the main menu. The menu option is marked with an asterisk (*) in the additional menu. The menu option appears in the main menu and can be selected and edited there.
	Confirming the set values	Confirming the menu option marked with an asterisk in the additional menu to remove it from the main menu.

18.3 Auxiliary functions that can be enabled



The functions shown in grey are valid for the “Process controller” option (P.xxx) or for the “Analogue feedback” option (OUTPUT).

Function	Description
<i>CHARACT</i>	Selecting the characteristic type
<i>CUTOFF</i>	Enabling and configuring the sealing function
<i>DIR.CMD</i>	Setting the effective direction of the input signal for the set-point value to position the valve actuator
<i>DIR.ACT</i>	Setting the effective direction of the pressurisation state of the valve actuator to the actual position
<i>SPLTRNG</i>	Splitting the standard signal range between several devices Not available for process controller option!
<i>X.LIMIT</i>	Limiting the mechanical stroke range
<i>X.TIME</i>	Reducing the control speed
<i>X.CONTRL</i>	Parameterising the position control
<i>CODE</i>	Enabling and configuring the code protection
<i>SAFEPOS</i>	Setting the safety position
<i>SIG-ERR</i>	Configuring the signal error detection
<i>BIN-IN</i>	Setting the function of the digital input
<i>CAL.USER</i>	Changes to the factory calibration through the user
<i>SET.FACT</i>	Factory reset
<i>SER-I/O</i>	Serial service interface configuration (for internal use only)
<i>ENDFUNCT</i>	Return to the main menu <i>ADDFUNCT</i>
Process controller option:	
<i>P.CONTRL</i>	Parameterising the process control
<i>P.Q'LIN</i>	Starting the routine for linearising the process characteristic (only useful if flow control is to be carried out)
<i>P.CO TUNE</i>	Carrying out self-optimisation of the process controller
“Analogue feedback” option:	
<i>OUTPUT</i>	Configuring outputs

Table 7: Auxiliary functions of the SideControl Type 8635 that can be enabled

18.4 Factory settings of the auxiliary functions



The functions and factory settings shown in grey are valid for the “Process controller” option (P.xxx) or for the “Analogue feedback” option (OUTPUT).

Function	Factory setting
<i>CHARACT</i>	<i>CHA LIN</i>
<i>CUTOFF</i>	<i>CUT_⊥ = 0%; CUT_τ = 100%</i>
<i>DIR.CMD</i>	<i>DIR.CRISE</i>
<i>DIR.ACT</i>	<i>DIR.ARISE</i>
<i>SPLTRNG</i>	<i>SR_⊥ = 0 (%); SR_τ = 100 (%)</i>
<i>X.LIMIT</i>	<i>LIM_⊥ = 0%; LIM_τ = 100%</i>
<i>X.TIME</i>	
<i>T.OPN</i>	Values determined by <i>X.TUNE</i> ; after executing <i>SET.FACT</i> : 1s
<i>T.CLS</i>	
<i>X.CONTRL</i>	
<i>X.CO DBND</i>	1%
<i>P.CO PARA</i>	
<i>KX_τ</i>	Values determined by <i>X.TUNE</i> ; after executing <i>SET.FACT</i> : 1
<i>KX_⊥</i>	
<i>CODE</i>	<i>CODE 0000</i>
<i>SAFEPOS</i>	0
<i>BIN-IN</i>	<i>B.IN SPOS / NORM</i>
<i>P.CONTRL</i>	
<i>P.CO DBND</i>	1%
<i>P.CO PARA</i>	
<i>KP</i>	1.00
<i>TN</i>	999.9
<i>TV</i>	0.0
<i>X0</i>	0
<i>P.CO SETP</i>	<i>SETP INT</i>
<i>P.CO FILT</i>	0
<i>P.CO SCAL</i>	<i>PV_⊥000.0, PV_τ100.0</i>
<i>P.CO TUNE</i>	<i>D'ACT</i>
<i>OUTPUT</i>	
<i>OUT ANL:</i>	
<i>ANL POS</i>	<i>ANL 4'20A</i>
<i>OUT BIN1/BIN2:</i>	
<i>BIN1or2DEV</i>	<i>DEV.X 1.0% NORM OPN</i>

Table 8: Software factory settings

18.5 Enabling and disabling auxiliary functions

The configuration menu consists of the main menu and the additional menu.

The main menu initially contains the basic functions that are specified during initial start-up. The additional menu comprises supplementary functions and can be accessed via the menu option `ADDFUNCT` in the main menu.

Device functions and device parameters can be specified within the main menu. If required, the main menu can be extended by functions from the additional menu, which can then be specified.

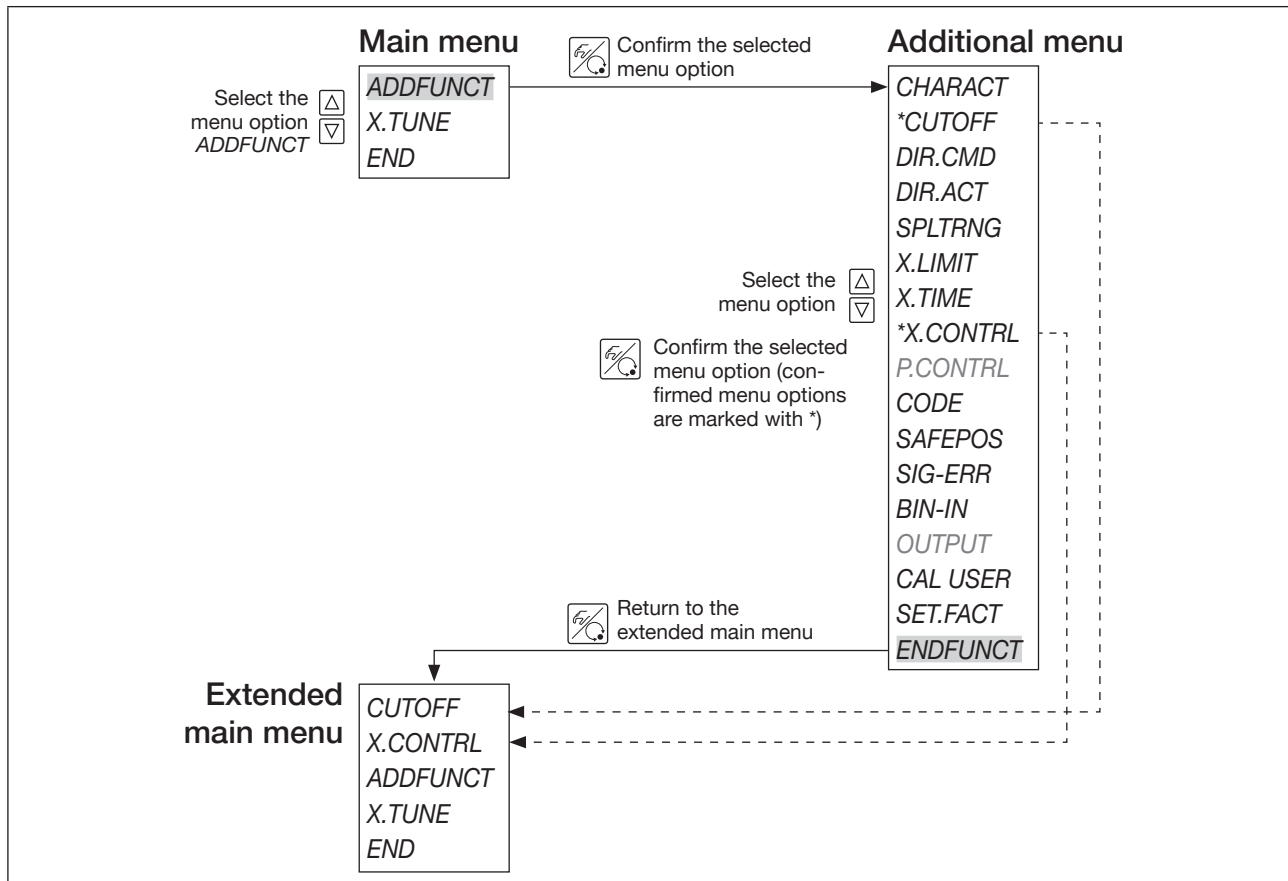

Figure 28: Principle of including auxiliary functions in the main menu

Enabling auxiliary functions:

→ Select and confirm the desired function in the additional menu.

- ✓ The function is marked with an asterisk.
After returning to the main menu, the function is part of the main menu.

Disabling auxiliary functions:



! Removing a function from the main menu invalidates the settings previously made under that function.

→ Select and confirm the function to be disabled in the additional menu.

- ✓ The marking (*) is removed.
After returning to the main menu, the function is no longer part of the main menu.

18.6 Setting numerical values

Numerical values are set in the menu options provided for this purpose by pressing the arrow keys once or several times. With four-digit numbers, only the flashing position can be set with the arrow keys. Pressing the MANUAL/AUTOMATIC key advances to the next position.

Key	Function
	Incrementing (increasing) numerical values
	Decrementing (reducing) numerical values
	With multi-digit numbers, advancing to the next position

18.7 Overview of the auxiliary functions



In order to be able to edit auxiliary functions, they must first be included in the main menu (see section “18.5” on page 50).

Removing a function from the main menu invalidates the settings previously made under that function.

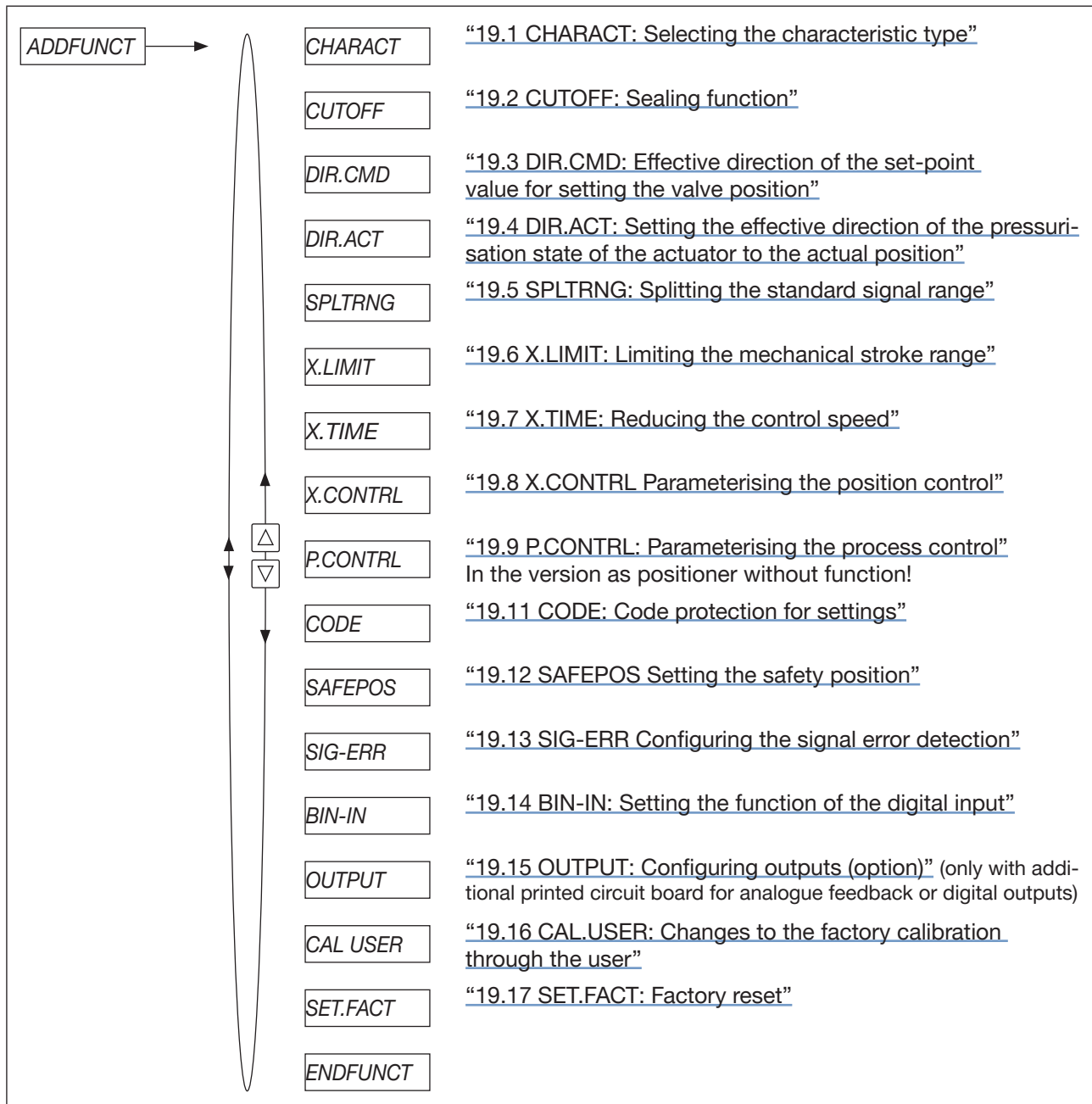

19 DESCRIPTION OF THE AUXILIARY FUNCTIONS



In order to be able to edit auxiliary functions, they must first be included in the main menu (see section “18.5” on page 50).

Removing a function from the main menu invalidates the settings previously made under that function.

19.1 CHARACT: Selecting the characteristic type

This function is used to select the correction characteristic which is used to correct the flow characteristic and the operating characteristic in relation to the set-point position (CMD) and the valve stroke (POS).

Factory setting: Characteristic correction disabled, linear characteristic (*CHA LIN*)

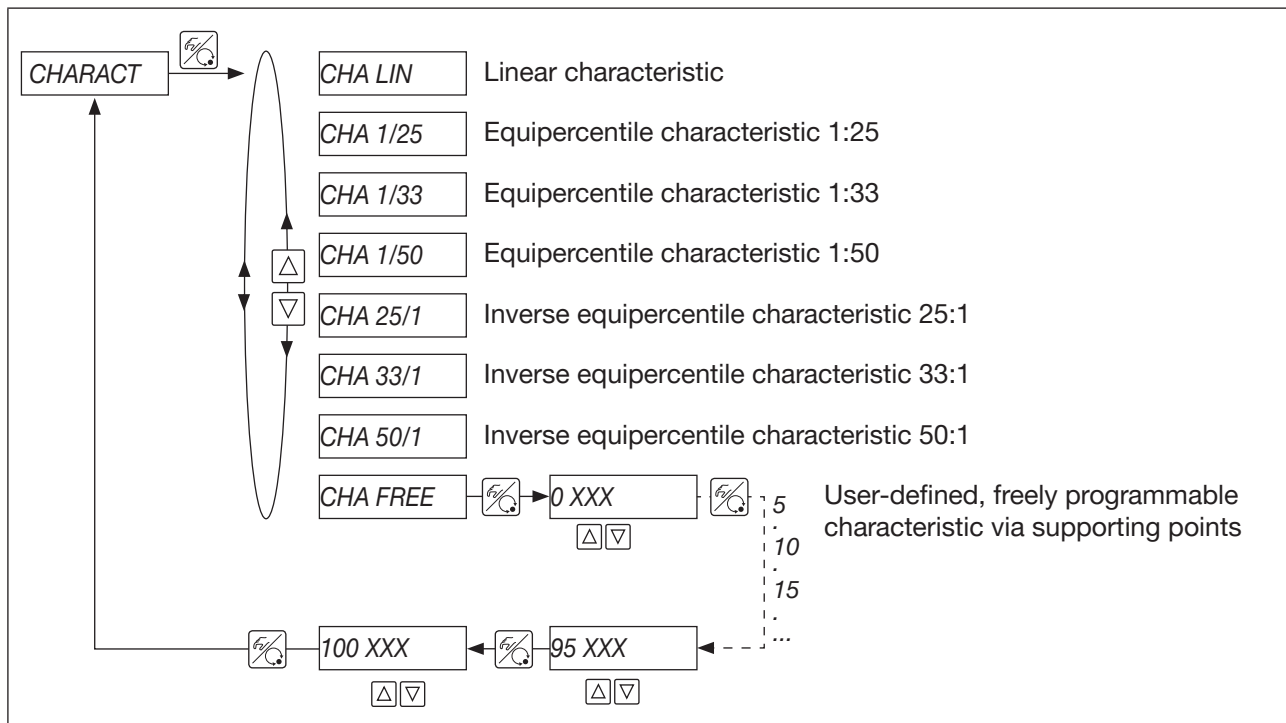

Figure 29: Operating structure CHARACT

Flow characteristic:

The flow characteristic $k_v = f(s)$ indicates the flow rate of a valve, expressed by the k_v value, as a function of the stroke s of the actuator spindle. The flow characteristic is determined by the shape of the valve seat and the valve seat seal. In general, 2 types of flow characteristics are implemented, the linear flow characteristic and the equipercentile flow characteristic.

With linear characteristics, the same k_v value changes dk_v are allocated to the same stroke changes ds :

$$dk_v = n_{lin} \cdot ds$$

With equipercentile characteristics, a change in stroke ds corresponds to an equipercentile change in the k_v value:

$$dk_v/k_v = n_{equiper} \cdot ds$$

Operating characteristic:

The operating characteristic $Q = f(s)$ shows the relationship between the volume flow Q in the installed valve and the stroke s . The properties of the pipelines, pumps and consumers are included in this characteristic. The operating characteristic therefore has a different shape than the flow characteristic.

For positioning applications of controllers, special requirements are often placed on the operating characteristic, e.g. linearity. For this reason, it is necessary to correct the operating characteristic in an appropriate manner. A transmission element is therefore provided in the device, which ensures various characteristics. These characteristics are used to correct the operating characteristic.

Equipercntile characteristics 1:25, 1:33, 1:50, 25:1, 33:1 and 50:1 as well as a linear characteristic can be set. In addition, it is possible to program a user-defined characteristic by entering supporting points.

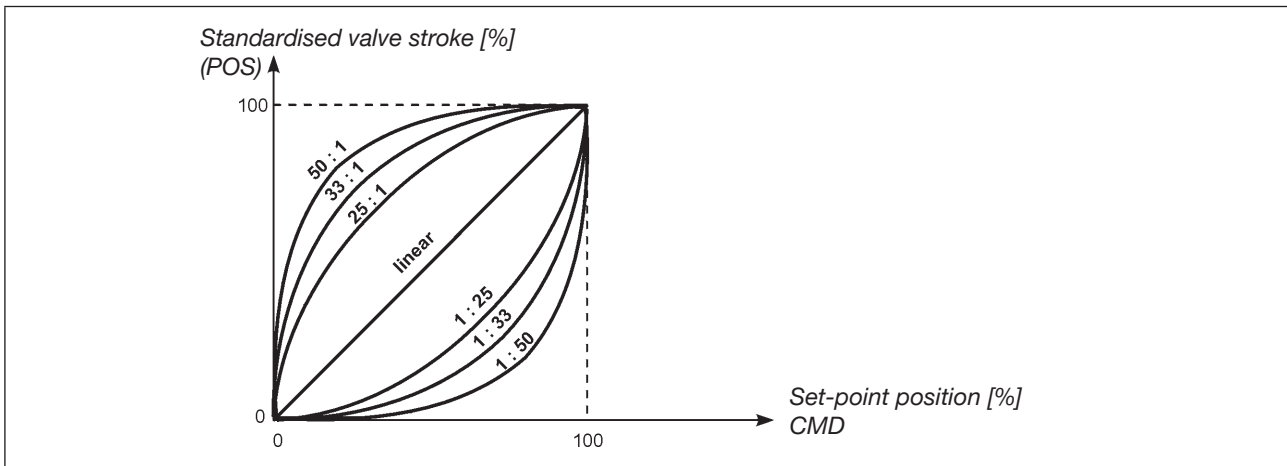

Figure 30: Characteristic correction (CHARACT)

MAN 1000011213 EN Version: L Status: RL (released | freigegeben) printed: 08.05.2026

19.1.1 Programming user-defined characteristics

The characteristic is defined via 21 supporting points in 5% increments, which are evenly distributed over the set-point range from 0...100%. A freely selectable stroke (setting range 0...100%) can be assigned to each supporting point.



The difference between the stroke values of two adjacent supporting points must not be greater than 20%.

Recommendation: Make a note of the entered supporting points in the table in the appendix.

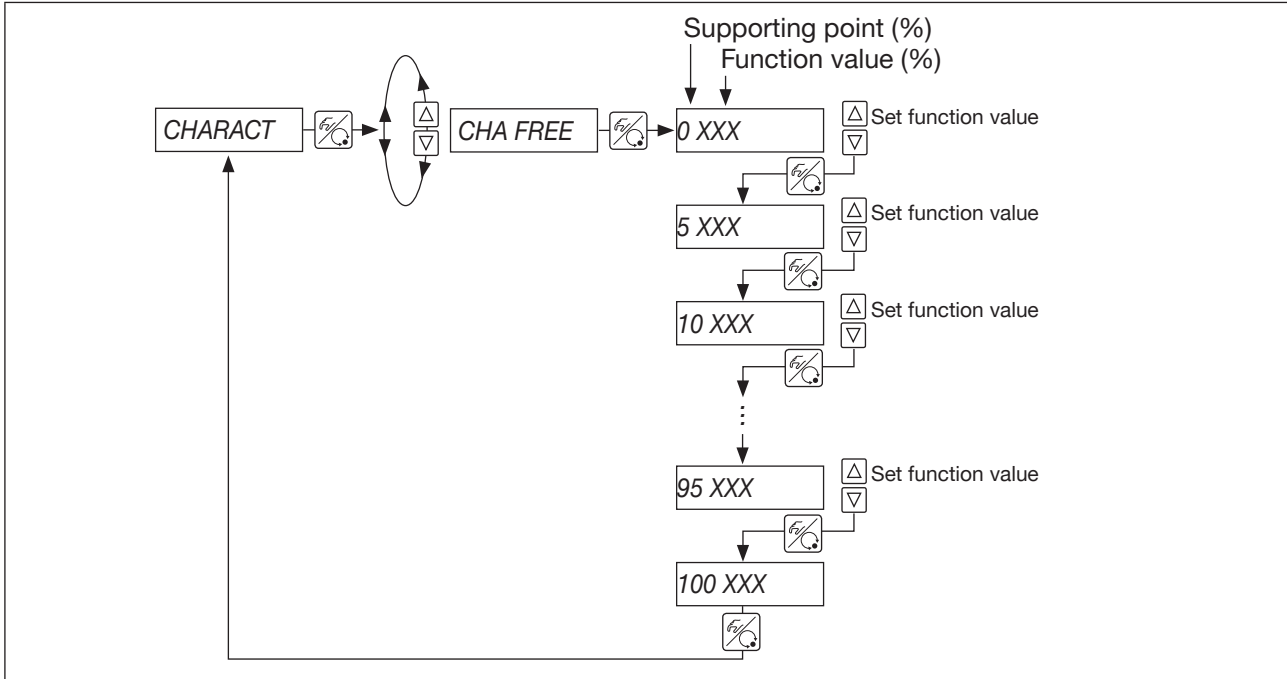

Figure 31: Operating structure CHA FREE

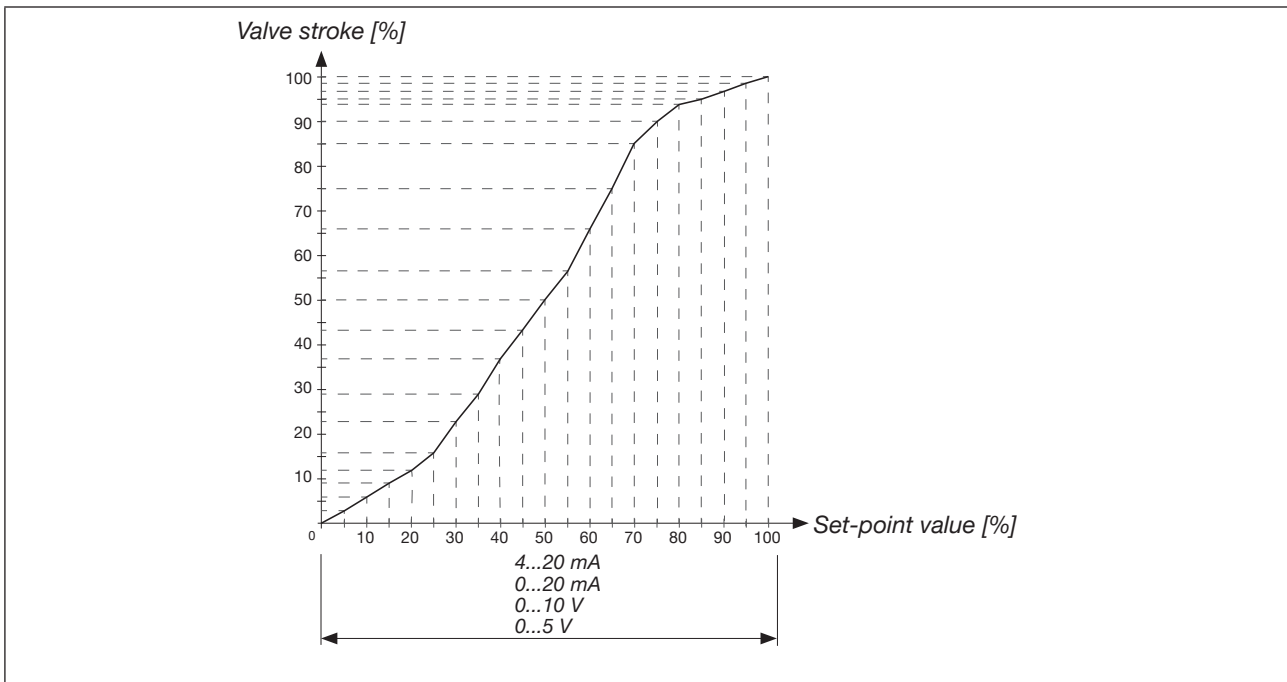

Figure 32: Example of a programmed characteristic (CHA FREE)

MAN 1000011213 EN Version: L Status: RL (released | freigegeben) printed: 08.05.2026

19.2 CUTOFF: Sealing function

This function causes the valve to seal tightly or to open fully within an adjustable range.

The limits for the set-point position (CMD) above which the actuator is fully exhausted or pressurised are set in percent. The transition from the set range to normal operation takes place with a hysteresis of 1%.

When the process valve is in the sealing area, a flashing MIN or MAX symbol appears on the display.

Factory setting: Sealing function disabled ($CUT_{\perp} = 0$; $CUT_{\top} = 100$)

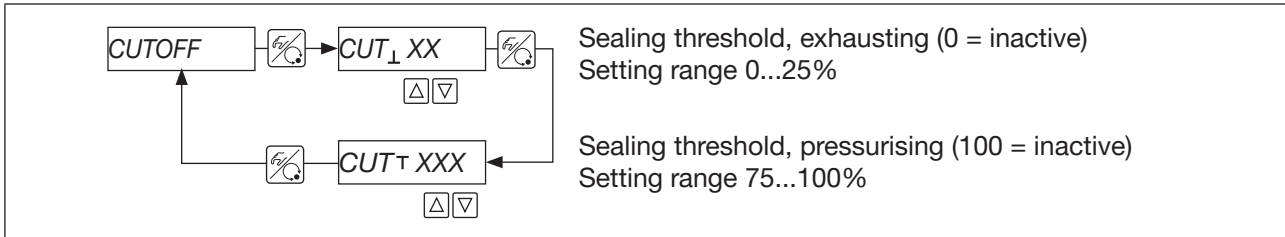

Figure 33: Operating structure CUTOFF

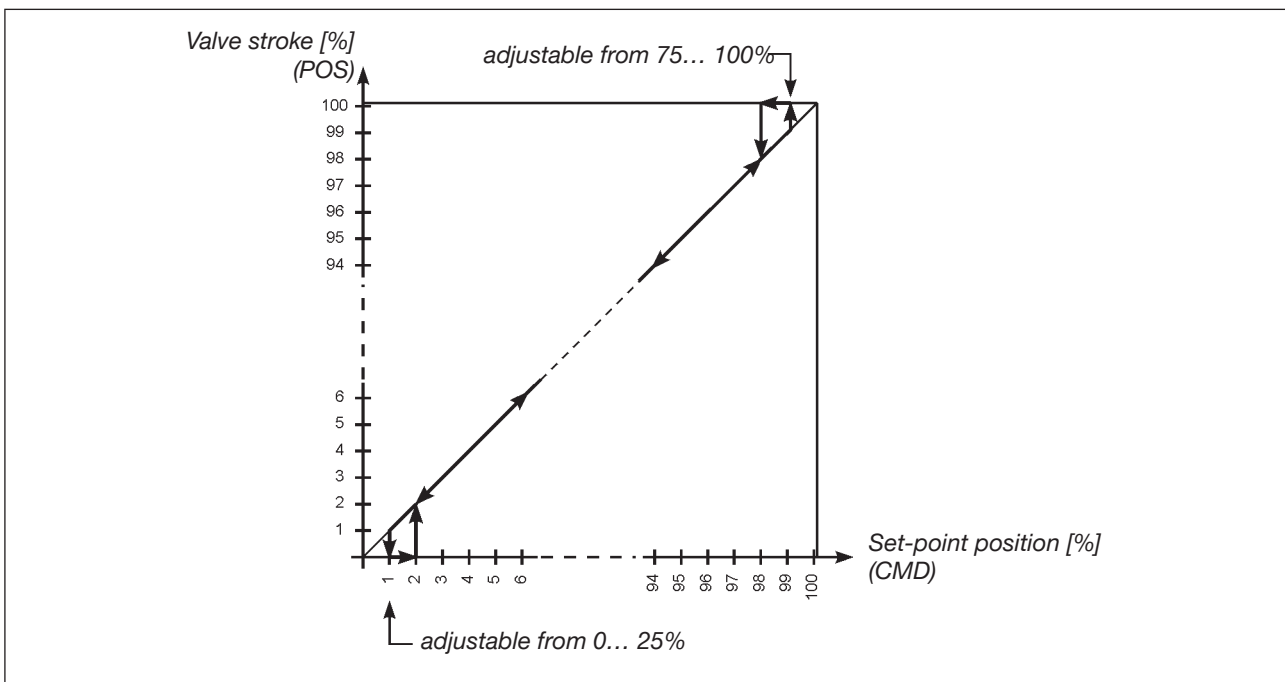

Figure 34: Sealing function (CUTOFF)

19.3 DIR.CMD: Effective direction of the set-point value for setting the valve position

This function impacts the relationship between the input signal for the set-point value (INPUT) and the position of the valve actuator. It is possible to toggle between direct effective direction and inverse effective direction.

Factory setting: rise (*DIR.CRISE*)

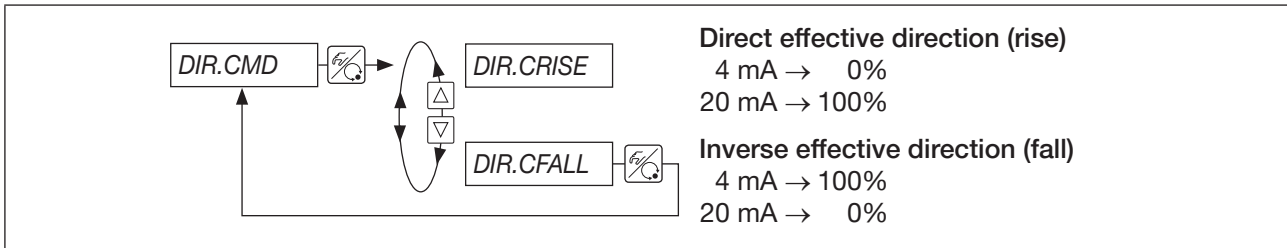

Figure 35: Operating structure *DIR.CMD*

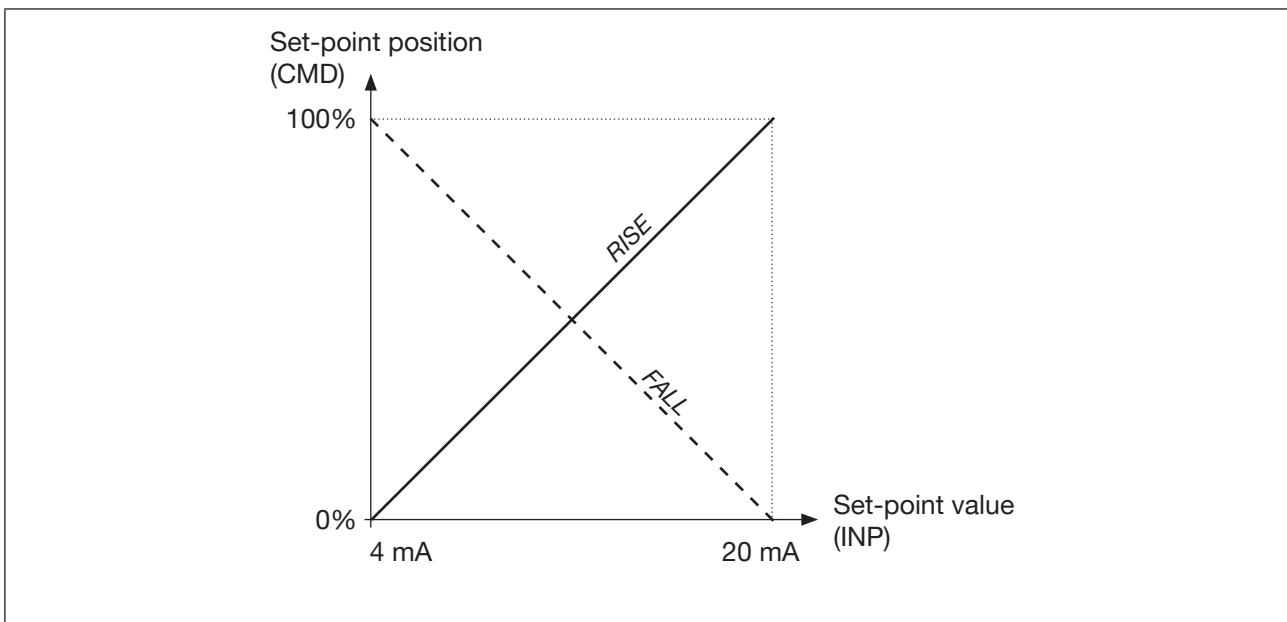

Figure 36: Effective direction of set-point value to valve position (set-point position *CMD*)

19.4 DIR.ACT: Setting the effective direction of the pressurisation state of the actuator to the actual position

This function influences the relationship between the state of pressurisation of the valve actuator and the actual position (POS). It is possible to toggle between direct effective direction (NC) and inverse effective direction (NO).

Factory setting: Direct effective direction (rise, *DIR.ARISE*)

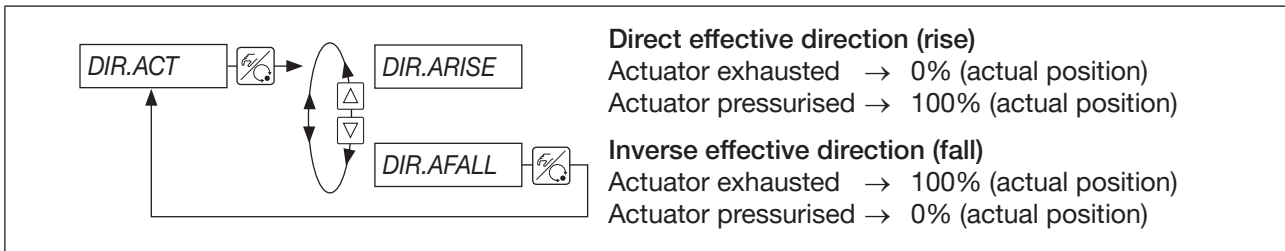

Figure 37: Operating structure DIR.ACT

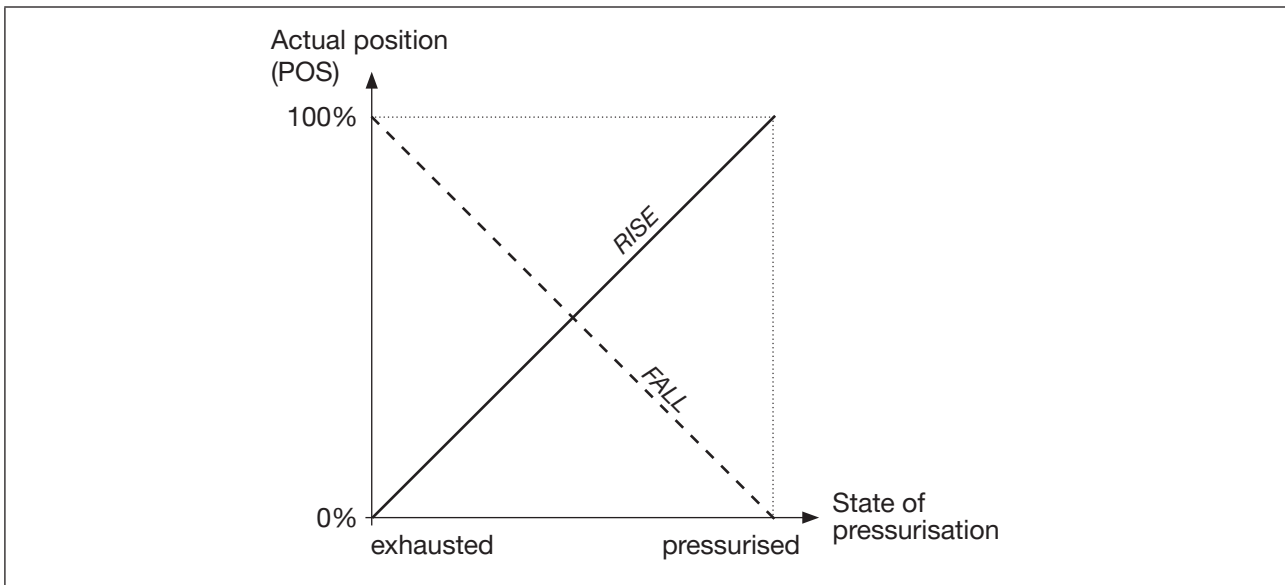

Figure 38: Effective direction of the state of pressurisation to the actual position (DIR.ACT)

Control function of the control valve	State of pressurisation of the actuator	Effective direction
A	NC (actuator pressurised = valve closed)	rise (<i>DIR.ARISE</i>)
B	NO (actuator exhausted = valve opened)	fall (<i>DIR.AFALL</i>)

19.5 SPLTRNG: Splitting the standard signal range

This function can be used to split the standard signal range between several devices. The standard signal for the set-point position is limited here by a minimum and a maximum value.

The limited standard signal range covers the entire stroke range of the valve.

The signal range can be split without or with overlapping.

Several valves can be used **alternately** as actuators without overlapping.

Overlapping allows multiple valves to be used **simultaneously** as actuators.



This function is only effective during operation as a positioner.

Factory setting: Minimum value = 0%,
 Maximum value = 100%
 ($SR_{\perp} = 0$; $SR_{\top} = 100$)

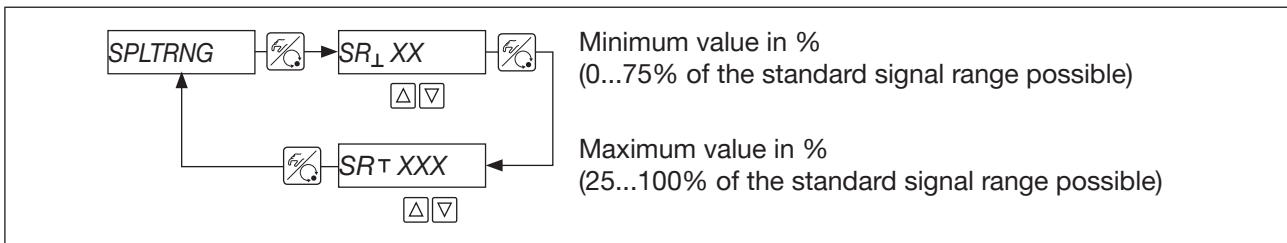

Figure 39: Operating structure SPLTRNG

Example: Splitting the standard signal into 2 set-point ranges

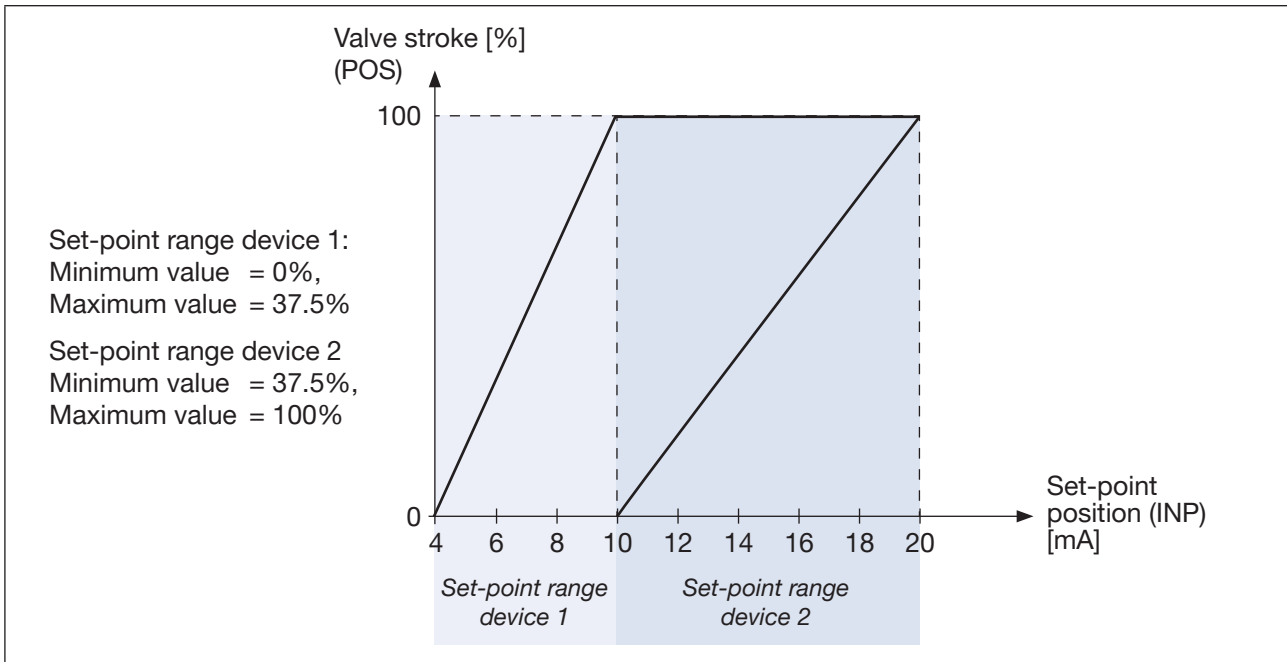

Figure 40: Splitting the standard signal 4...20 mA into 2 set-point ranges (SPLTRNG)

19.6 X.LIMIT: Limiting the mechanical stroke range

This function limits the (physical) stroke to preset percentage values (start value and end value). The stroke range of the limited stroke is thereby set to 100%. If the limited stroke range is exceeded during operation, negative actual positions or actual positions greater than 100% are displayed.



The minimum separation between the start value and the end value of the stroke range is 50%. When entering a value with a minimum separation of < 50%, the other value is automatically adjusted.

Factory setting: Bottom stroke limitation = 0%,
Top stroke limitation = 100%
($LIM_{\perp} = 0$; $LIM_{\top} = 100$)

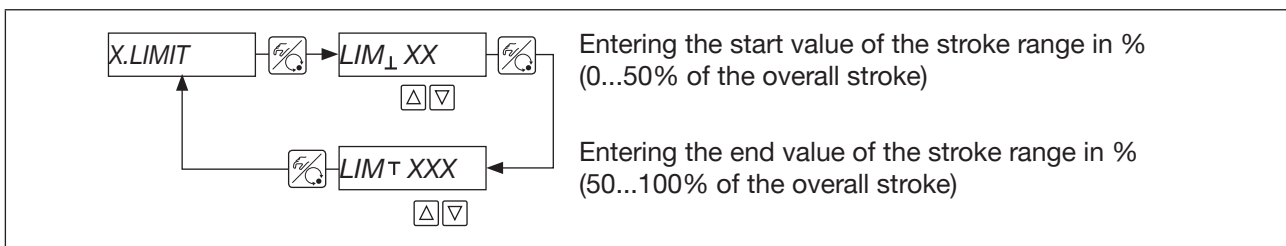

Figure 41: Operating structure X.LIMIT

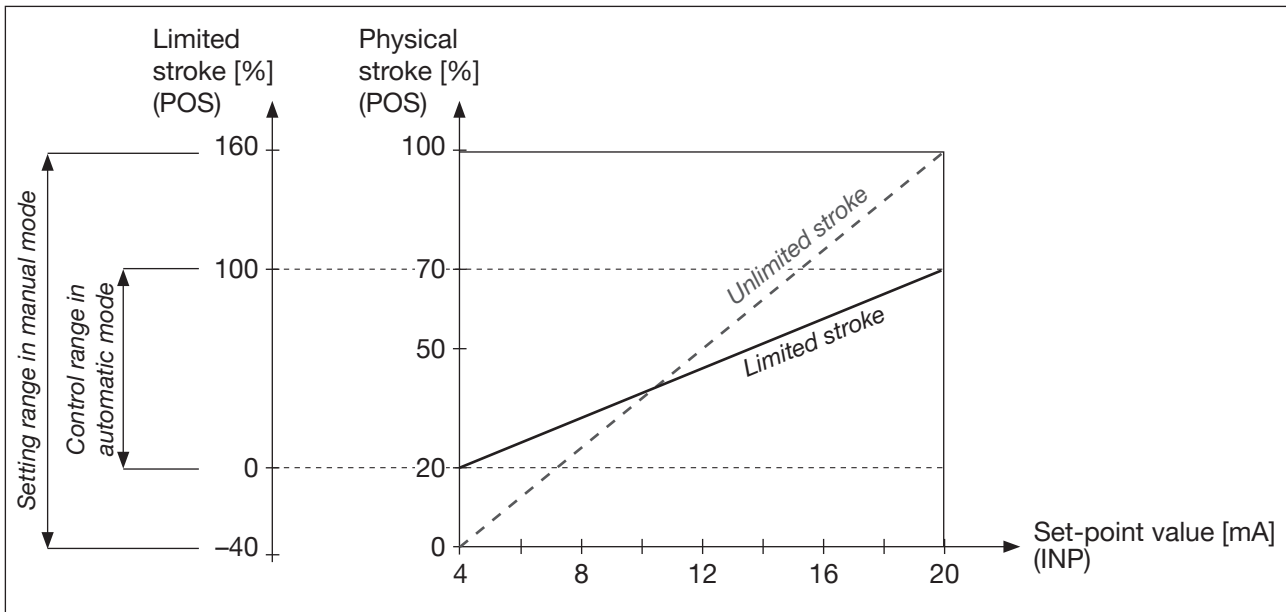

Figure 42: Limiting the mechanical stroke range (X.LIMIT)

19.7 X.TIME: Reducing the control speed

When executing the X.TUNE function, the minimum opening time for T.OPN and the minimum closing time for T.CLS are determined and stored for the overall stroke. It is thus moved at maximum control speed.

If the control speed is to be reduced, values can be entered for T.OPN and T.CLS which lie between the minimum values determined and 60 s.



If actuating times < 1 s are determined when executing the X.TUNE function, X.TIME is automatically included in the main menu. The affected value is automatically set to 1 s.

Factory setting: 1 s

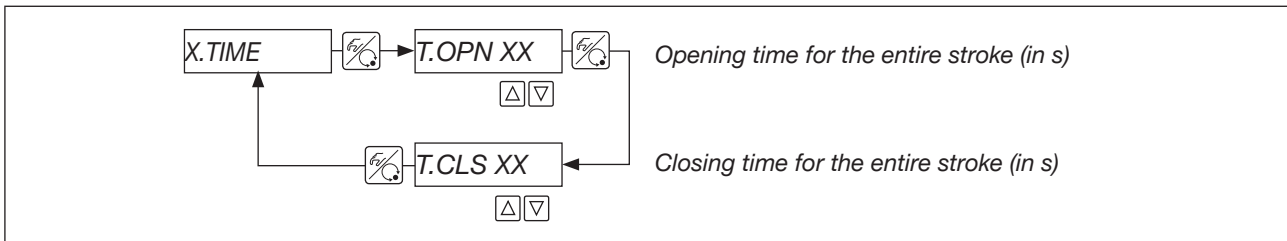
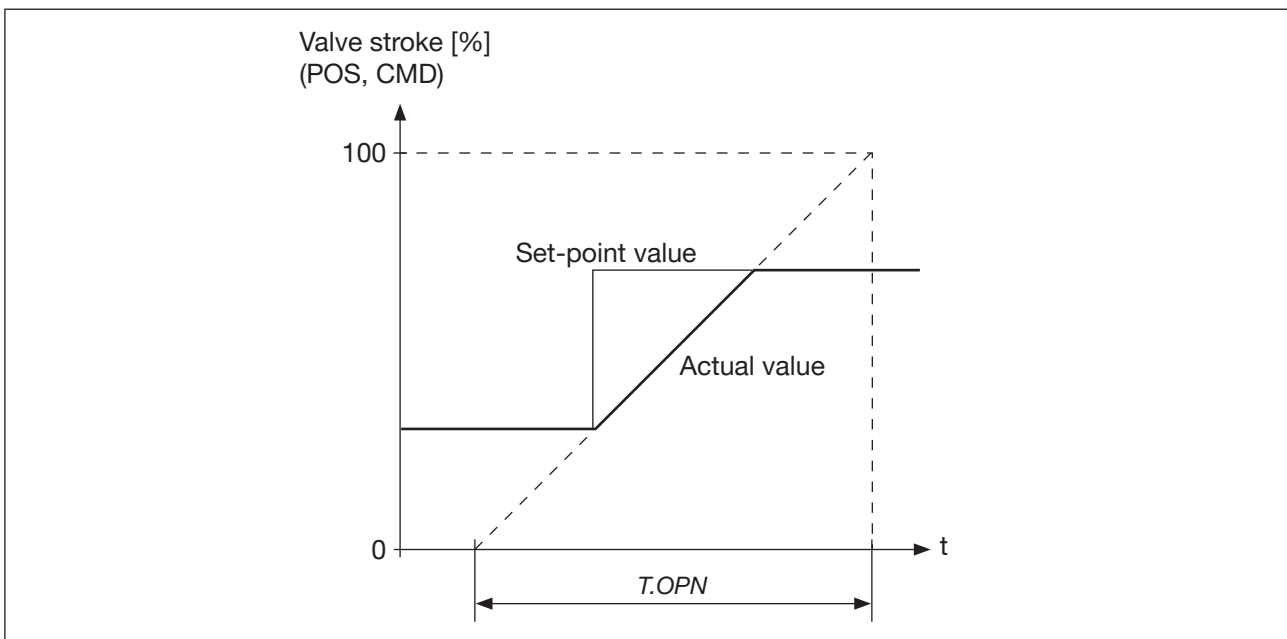

Figure 43: Operating structure X.TIME

Effect of the limited opening time after a set-point value step



19.8 X.CONTRL Parameterising the position control

This function is used to set (readjust) the position control parameters.



If the X.CONTRL function is enabled when carrying out X.TUNE, the insensitivity range X.CO DBND is automatically determined depending on the friction behaviour of the actuator. The value determined in this way is a guide value that can be readjusted manually.

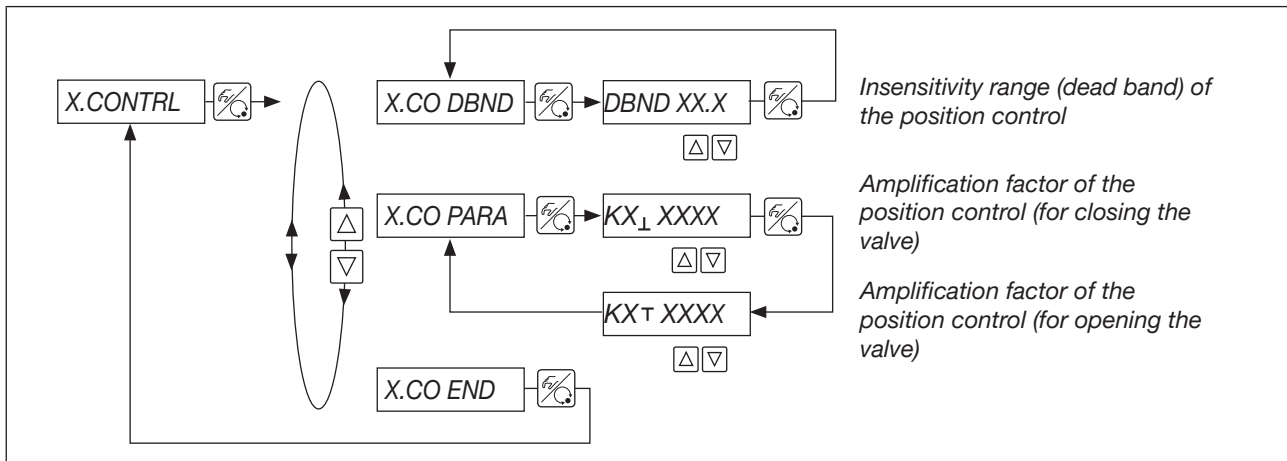

Figure 44: Operating structure X.CONTRL

X.CO DBND

Insensitivity range (dead band) of the position control

Factory setting: 1%

Entry of the insensitivity range in %, related to the stroke range limited in the X.LIMIT function.

This function is used to ensure that the position control only responds from a specific control difference onwards. This protects the solenoid valves of the SideControl and the pneumatic actuator of the control valve.

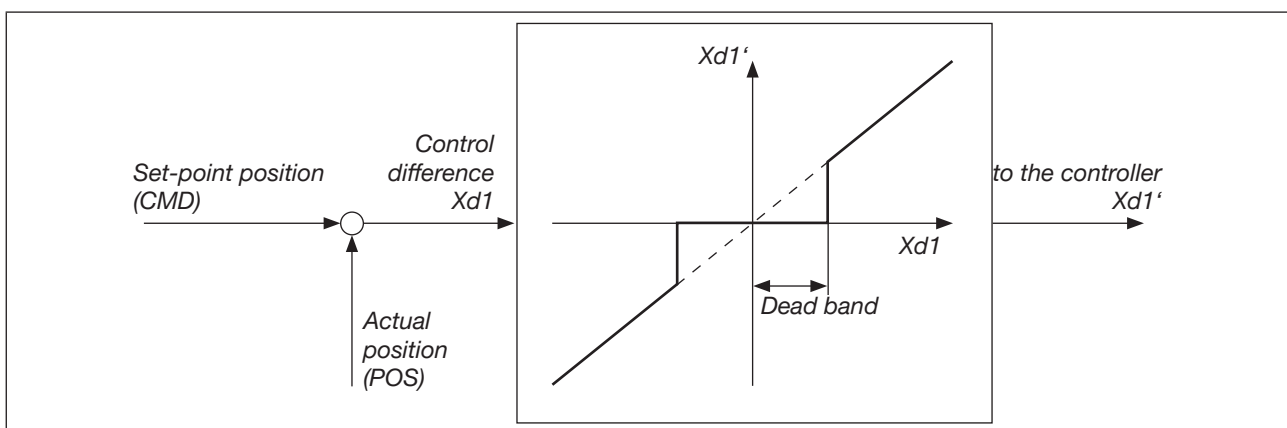

Figure 45: Insensitivity range of the position control

19.9 P.CONTRL: Parameterising the process control

This function is used to set (readjust) the process control parameters.

NOTE

► When setting up the process control, observe the sequence described in section “21 Start-up as process controller”.



When the *P.CONTRL* function is enabled, the *P.Q'LIN* function required for the process control is copied to the main menu.

P.Q'LIN automatically determines the supporting points for a correction characteristic (for further information, see “19.10 *P.Q'LIN*: Linearisation of the process characteristic”)

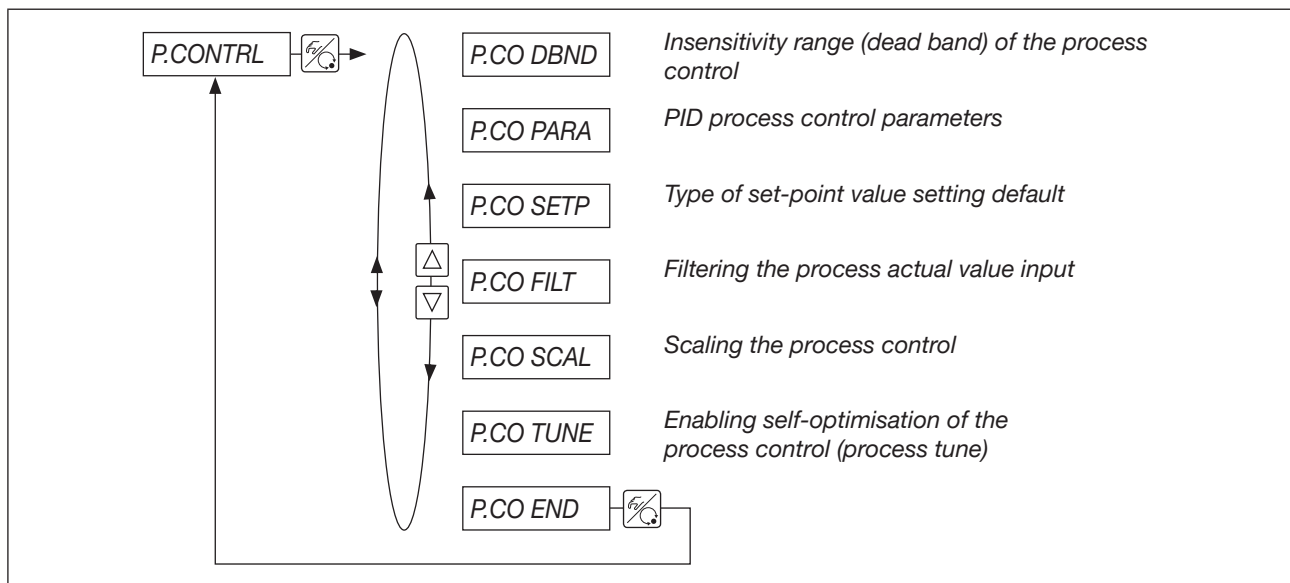

Figure 46: Operating structure of the *P.CONTRL* auxiliary function

19.9.1 P.CO DBND: Insensitivity range (dead band) of the process control

P.CO DBND

Factory setting: 1%

Entering the insensitivity range in %, related to the span of the process actual value scaled by SCAL PV₁ and PV_T.

This function is used to ensure that the process control only responds from a specific control difference onwards. This protects the actuating system of the SideControl and the pneumatic actuator of the control valve.

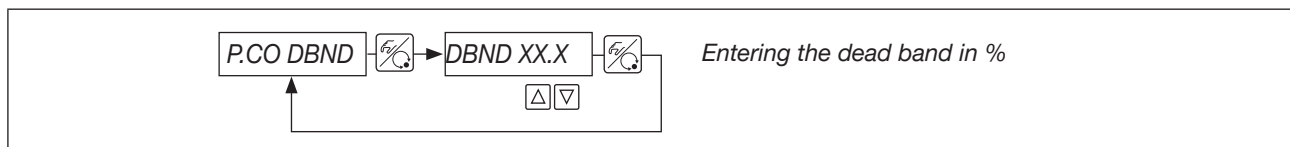

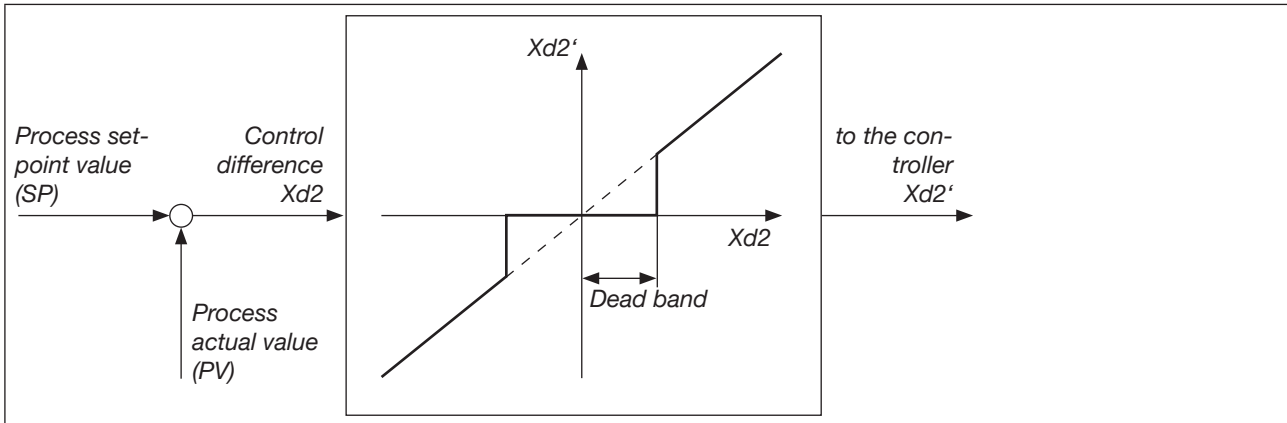

Figure 47: Insensitivity range of the process control

19.9.2 P.CO PARA: PID process control parameters



Make a note of the entered parameters in the table in the appendix from Page 104.

For the definition of the parameters of a PID controller, see section “27 Additional information” on page 92.

For self-optimisation of the PID parameters, see section “21.2 P.TUNE: Carrying out self-optimisation of the process controller” on page 83.

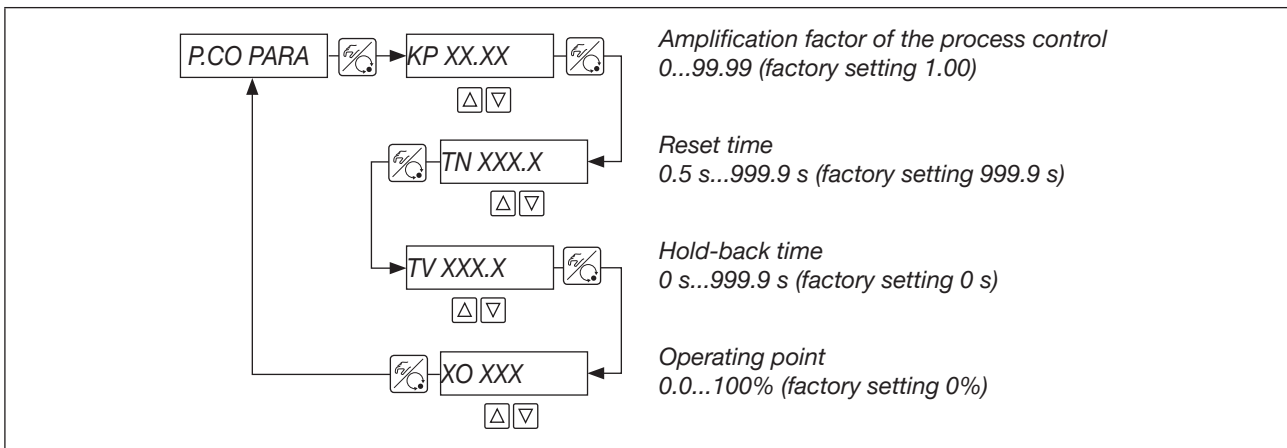

19.9.3 P.CO SETP: Type of set-point value setting default (internal/external)

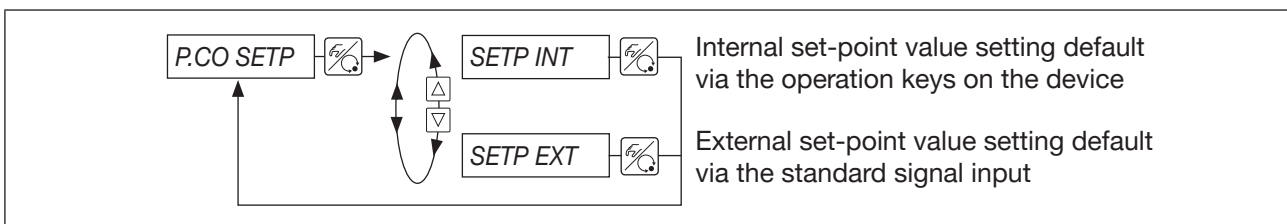

19.9.4 P.CO FILT: Filtering the process actual value input

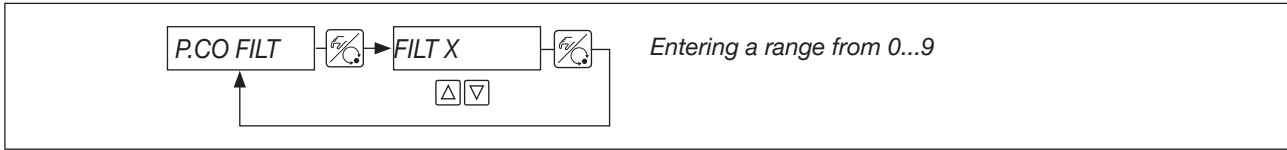

The filter has low-pass behaviour (PT1).

A range from 0...9 can be set, wherein the strength of the filter effect increases with the height of the range.

Factory setting: 0

Range	corresponds to a cut-off frequency (Hz) of	Effect
0	10	<div style="text-align: center;"> <p>minimum filter effect</p> <p>maximum filter effect</p> </div>
1	5	
2	2	
3	1	
4	0.5	
5	0.2	
6	0.1	
7	0.07	
8	0.05	
9	0.03	

19.9.5 P.CO SCAL: Scaling the process control

! The menu options SP_{\perp} and SP_{\top} are only active if *P.CO SETP / SETP EXT* has been selected.
 For *P.CO SETP / SETP INT*, it is possible to enter the set-point value directly according to the scaled measured variable (PV_{\perp} , PV_{\top}).

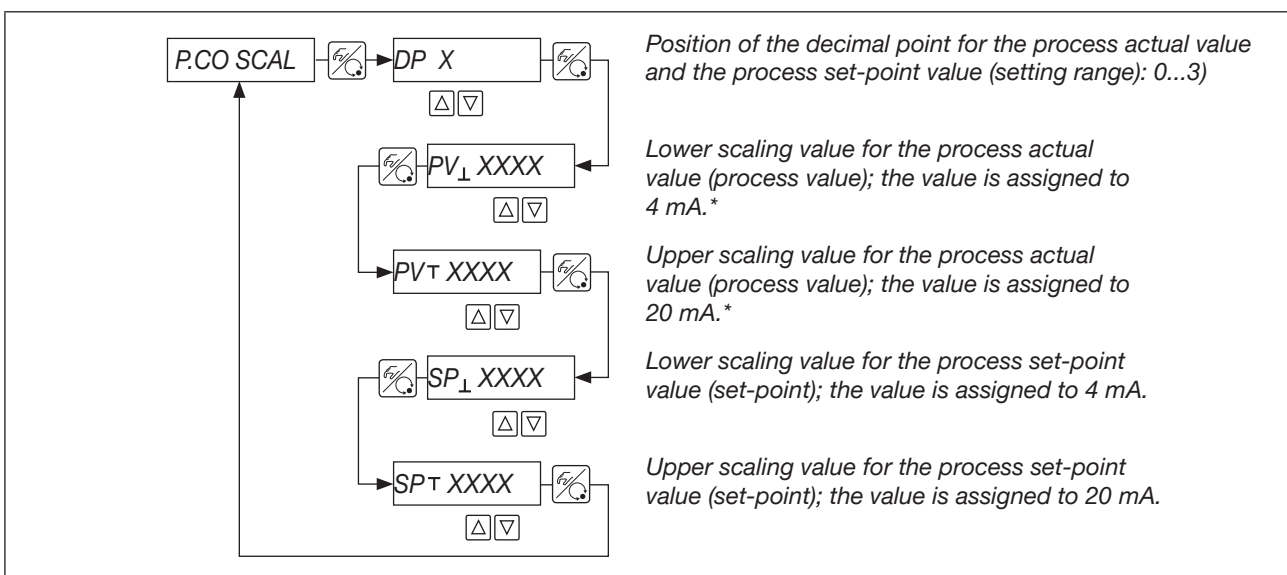

*) This setting defines the reference span for the dead band of the process controller and for the analogue feedback of the process actual value (option).

Example: Scaling the 4...20 mA input

Process actual value of the transmitter: 4...20 mA correspond to 0...10 l/min

Process set-point value of the PLC: 4...20 mA correspond to 0...8 l/min

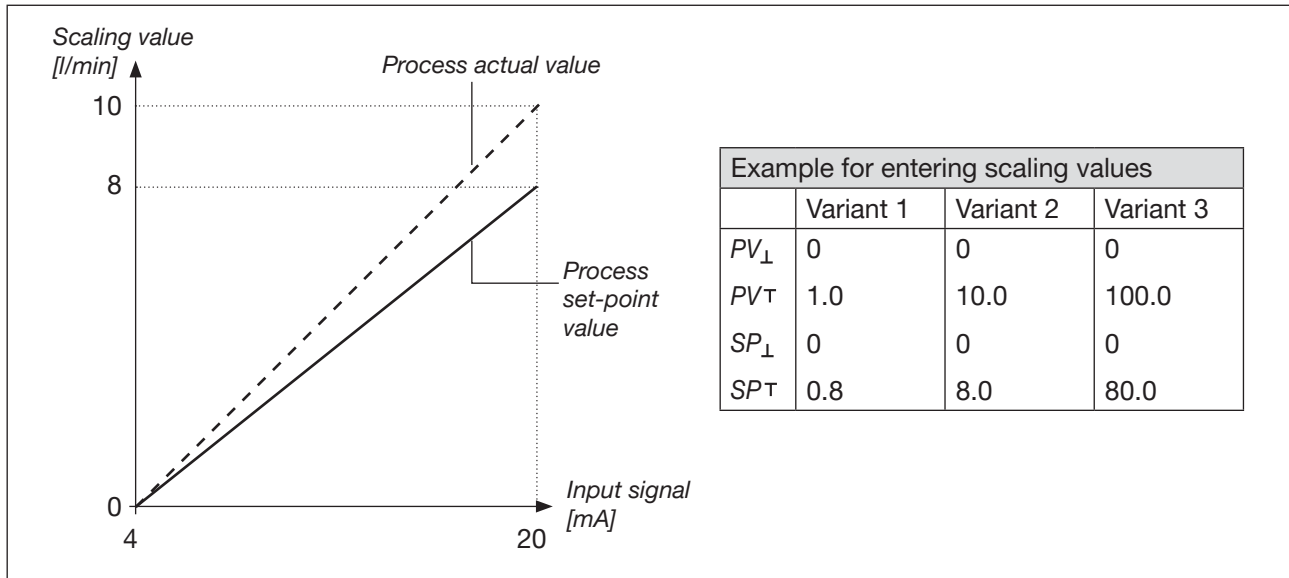

Select the number of decimal places as large as possible in order to achieve an optimum resolution. The amplification factor *KP* of the process controller refers to the scaling values set.

19.9.6 P.CO TUNE: Carrying out self-optimisation of the process controller

! This function is explained in detail in section “21.2 P.TUNE: Carrying out self-optimisation of the process controller” on page 83.

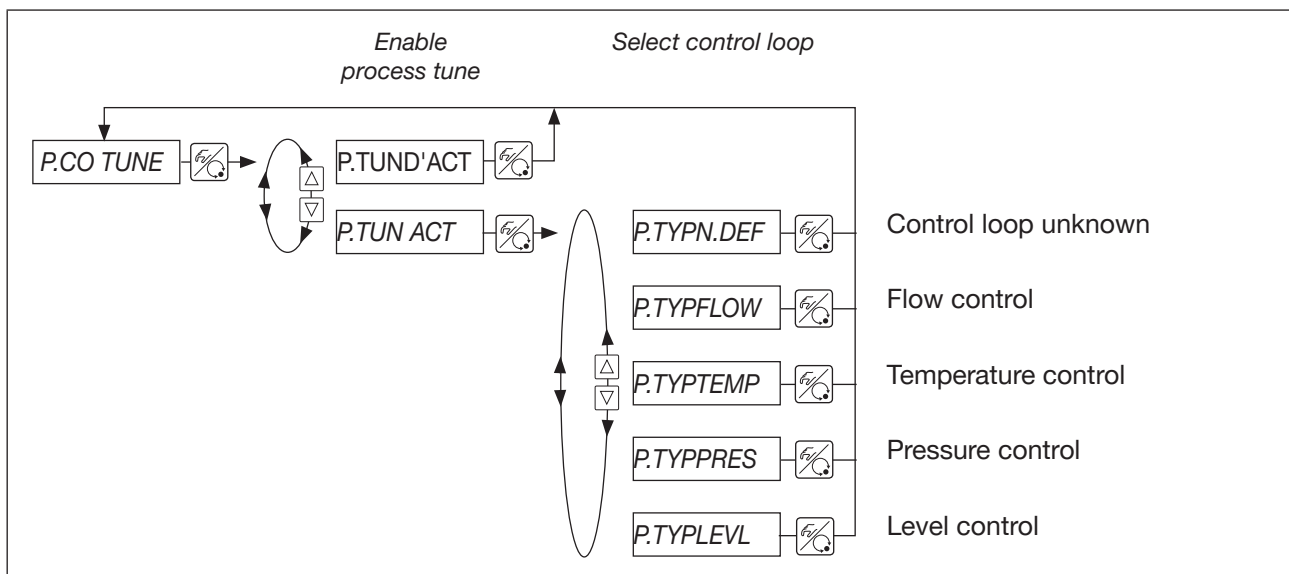

19.10 P.Q'LIN: Linearisation of the process characteristic

This function is used to automatically linearise the process characteristic by *P.Q'LIN* automatically determining the supporting points for a correction characteristic.



The *P.Q'LIN* function is automatically copied to the main menu when enabling the *P.CONTRL* function.

Executing P.Q'LIN:



Key	Action	Display shows	Result
	Select P.Q'LIN in the main menu	<i>P.Q'LIN</i>	P.Q'LIN can be started
	press for approx. 5 s	<i>P.Q'LIN 5...P.Q'LIN 0</i> ! <i>P.Q'LIN 0</i> ! <i>P.Q'LIN 1</i> ! <i>P.Q'LIN 2</i> ! <i>P.Q'LIN 3</i> : <i>P.Q'LIN.END</i> (flashing) or <i>Q.ERR X</i>	After the countdown has elapsed, the linearisation routine starts. Display of the supporting points that is currently being approached. The progress is indicated by a rotating bar at the left edge of the display. End of the routine Error message Digits to the right show the error number (for the error description, see section " Maintenance and troubleshooting " on page 87)
	press briefly	<i>P.Q'LIN</i>	The determined values are saved

Figure 48: Executing P.Q'LIN

The program increases the valve stroke from 0 to 100% in 20 increments and measures the corresponding measured variable. These value pairs are stored as a freely programmable characteristic under the menu option *CHARACT / CHA FREE* and can be viewed under this menu option.

If the menu option *CHARACT* has not been included in the main menu under the menu option *ADDFUNCT*, it is included automatically when executing the *P.Q'LIN* function. At the same time, the menu option *CHARACT / CHA FREE* is enabled.

19.11 CODE: Code protection for settings

The CODE function can be used to prevent unwanted access to the device settings. The code protection is enabled by entering a 4-digit numerical code into one of the sub-functions.



If the code protection is enabled, input of the set code is initially requested first for each locked operating action.

Factory setting: disabled (CODE 0000)

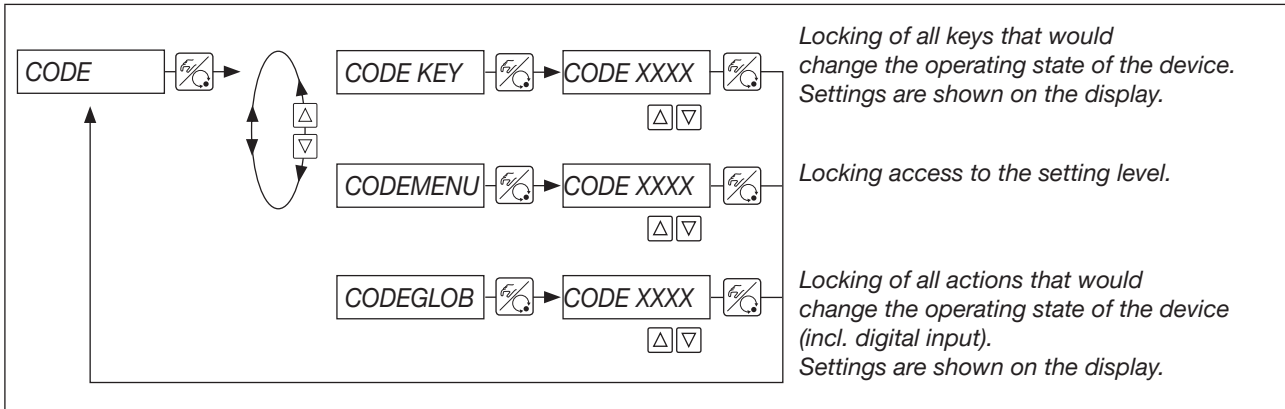

Figure 49: Operating structure of the CODE auxiliary function

Entering the numerical code:

- Changing the flashing position/digit
- Confirming the digit and toggling to the next position

19.12 SAFEPOS Setting the safety position

This function is used to set the safety position of the valve that is approached with defined signals (0% = closed, 100% = opened).



The safety position is only approached

- when a corresponding signal is present at the digital input (for configuration, see section “BIN-IN: Setting the function of the digital input” on page 71) or
- when a signal error occurs, if approaching the safety position is enabled in the SIG-ERR function (for configuration, see section “SIG-ERR Configuring the signal error detection” on page 70).

If the mechanical stroke range is limited with the *X.LIMIT* function, only safety positions within this limitation can be approached.

This function is only executed in AUTOMATIC operating state.

Factory setting: 0%

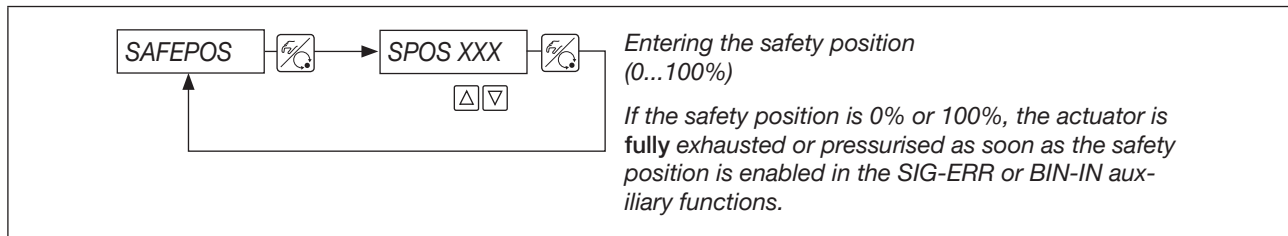

Figure 50: Operating structure SAFEPOS

With the fast pressurise / fast exhaust variant, two valves are controlled in each case to ensure faster pressurising and exhausting.

19.13 SIG-ERR Configuring the signal error detection

This function is used to determine whether a signal error is detected and which position the actuator assumes when a signal error is detected.



A 4...20-mA standard signal must be connected at the process actual value input. The device detects an error when the signal is $\leq 3.5\text{mA}$ ($\pm 0.5\%$ of the end value, hysteresis 0.5% of the end value).

If signal error detection has been configured and a signal error is detected, *PV FAULT* appears on the display at process level.

If the process controller is disabled, the *SIG-ERR* menu displays the message *NOT.AVAIL.*

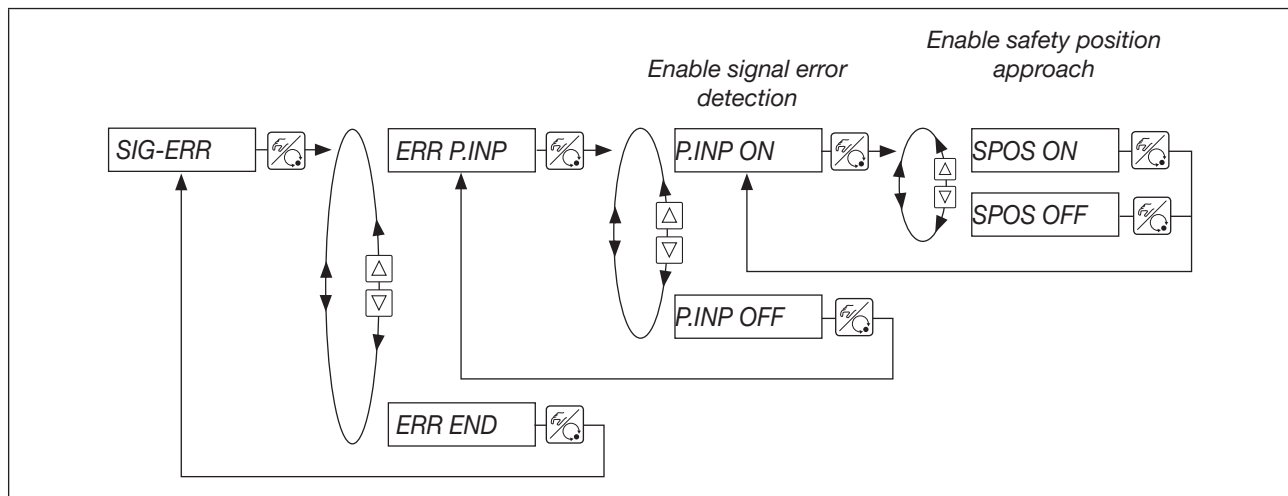

Figure 51: Operating structure of the SIG-ERR auxiliary function

Safety position SPOS ON enabled

The behaviour of the actuator in the event of a signal error and enabled menu option *SPOS ON* depends on the settings in the *SAFEPOS* auxiliary function.

SAFEPOS enabled:

In the event of a signal error, the actuator moves to the position set under *SAFEPOS*.

SAFEPOS disabled:

In the event of error detection, the actuator moves to the end position that it would assume in the zero-voltage state (see section "6.5" on page 21).

19.14 BIN-IN: Setting the function of the digital input

Use the *BIN-IN* auxiliary function to enable the digital input and to assign one of the two functions to it:

- Approach safety position or
- Toggle the operating state (MANUAL or AUTOMATIC)

Factory setting: disabled

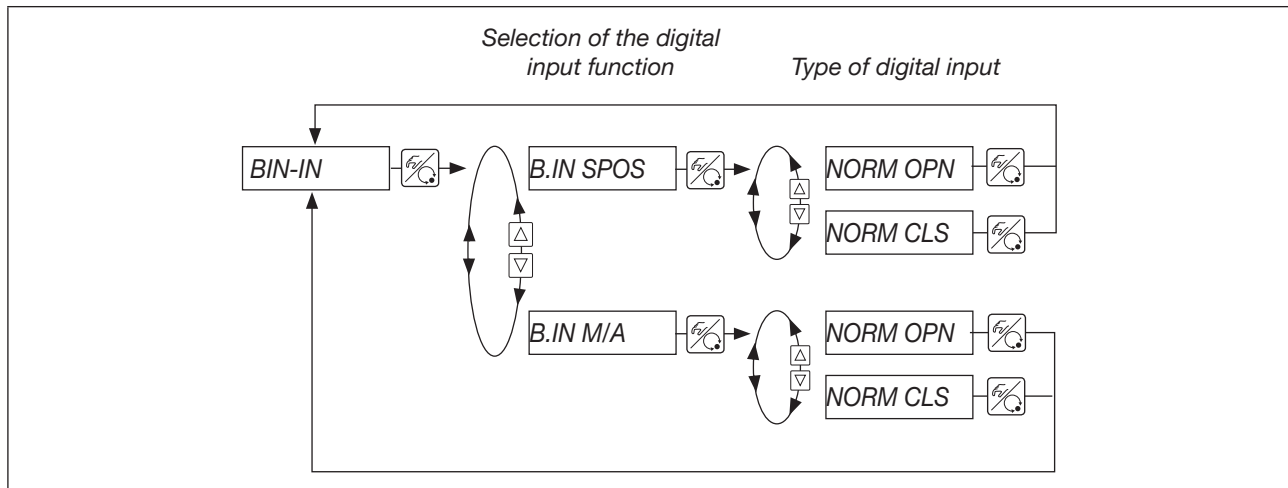

Figure 52: Operating structure of the BIN-IN auxiliary function

B.IN SPOS: Approach safety position

SAFEPOS enabled:

If the digital input is enabled, the actuator moves to the position defined in the SAFEPOS auxiliary function.

SAFEPOS disabled:

The actuator moves to the safety end position that it would assume in the event of electric and pneumatic auxiliary power failure (see section "6.5" on page 21).

B.IN M/A: Toggle the operating state

Toggle the operating state to MANUAL or AUTOMATIC

If the digital input has been activated, the device is set to MANUAL operating state.

If the digital input has not been activated, the device is set to AUTOMATIC operating state. Toggling via the HAND/AUTO key on the device is then no longer possible.

Type of digital input

Normally open → Mechanical normally open contact activated \triangleq Digital input activated

Normally closed → Mechanical normally closed contact activated \triangleq Digital input activated

19.15 OUTPUT: Configuring outputs (option)

This auxiliary function is used to determine which function is carried out by the analogue output and by the digital outputs.



This function is only available for the “Analogue feedback” and “2 digital outputs” options.

Factory setting:

Analogue output supplies actual position

Standard signal 4...20 mA

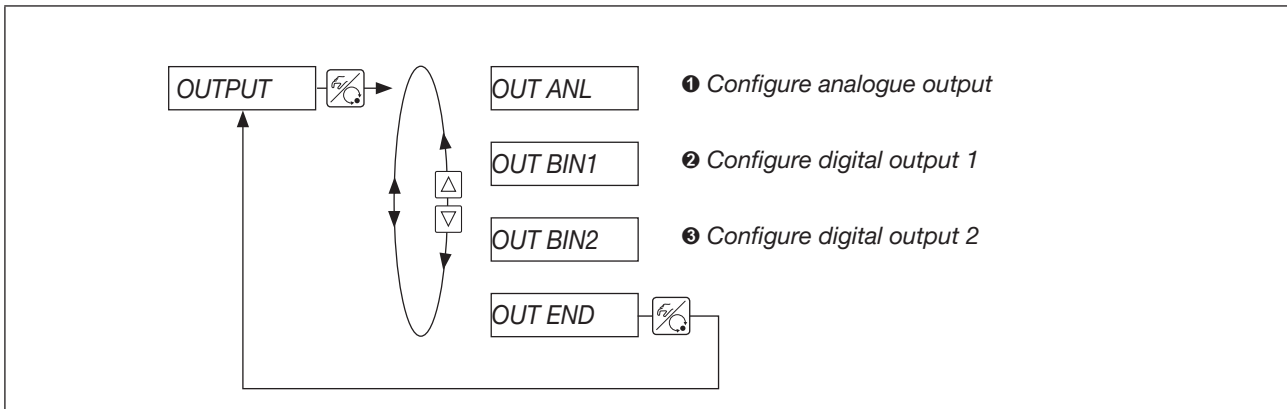

Figure 53: Operating structure of the auxiliary function OUTPUT – first sublevel

1 OUT ANL – Configuration of the analogue output

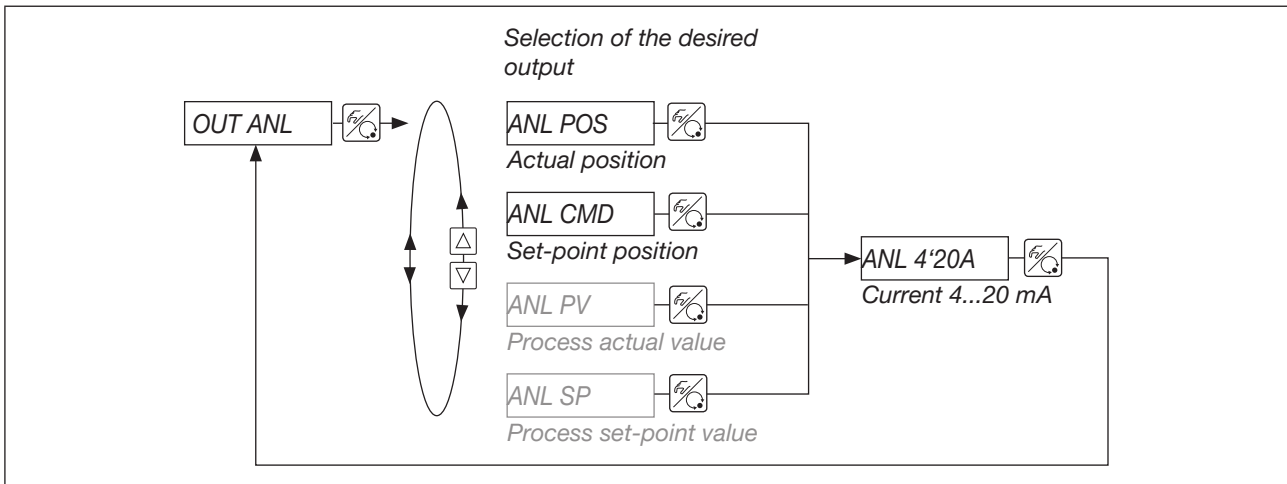
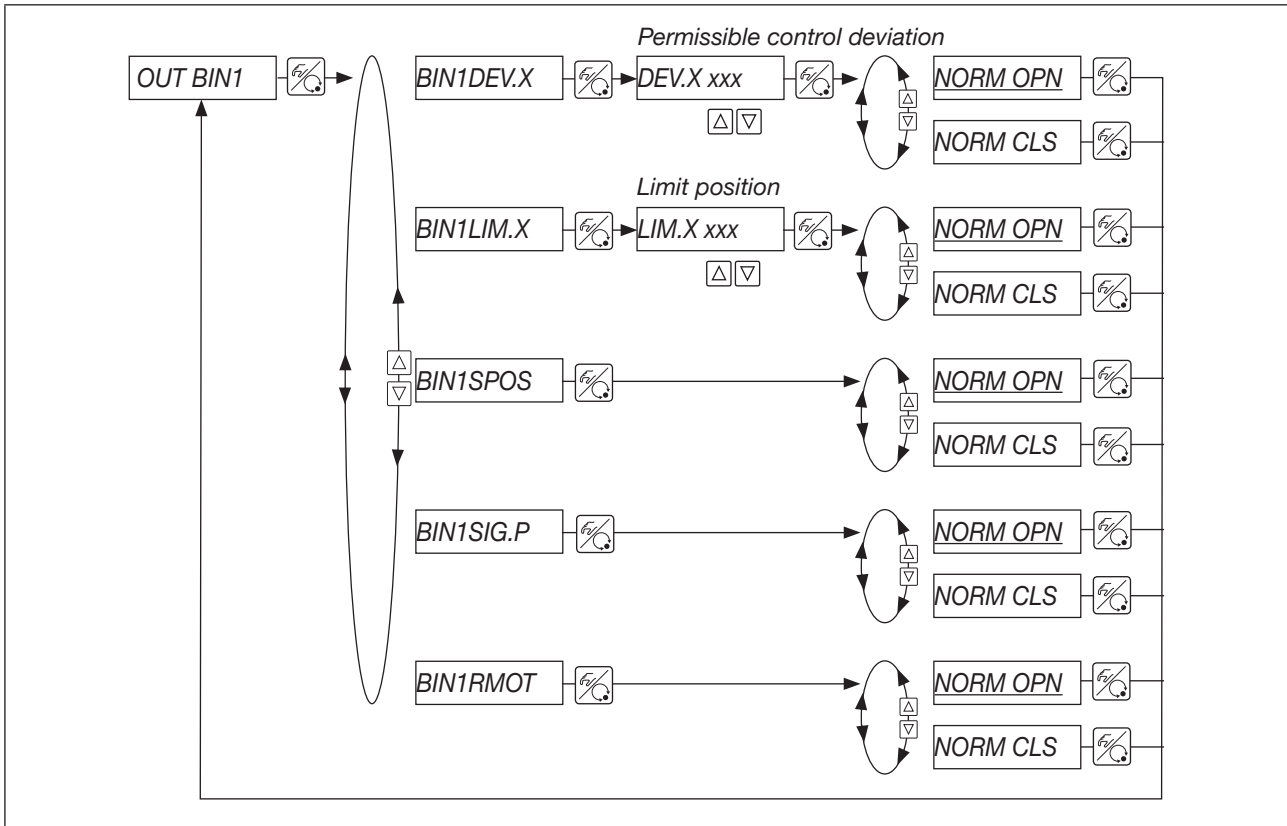

Figure 54: Operating structure of the menu option OUT ANL



The menu options shown in grey are only available for the “process controller” option.

OUT BIN1 – Configure digital output 1



! **NORM OPN:** “Normally Open” (NO) – output in switched state *high* (>2.1 mA)
NORM CLS: “Normally Closed” (NC) – output in switched state *low* (<1.2 mA)

Selection options:

BIN1DEV.X Alarm output for excessive control deviation of the positioner.
 The permissible control deviation *DEV.X xxx* must not be less than the dead band.

BIN1LIM.X Digital position output
LIM.X xxx = limit position

OUT BIN1	NORM OPN	NORM CLS
POS > LIM	<1.2 mA	>2.1 mA
POS < LIM	>2.1 mA	<1.2 mA

BIN1SPOS Actuator in safety position

BIN1SIG.P Error message, signal actual position

BIN1RMOT AUTOMATIC operating state and *external set-point value* active

③ OUT BIN2 – Configure digital output 2

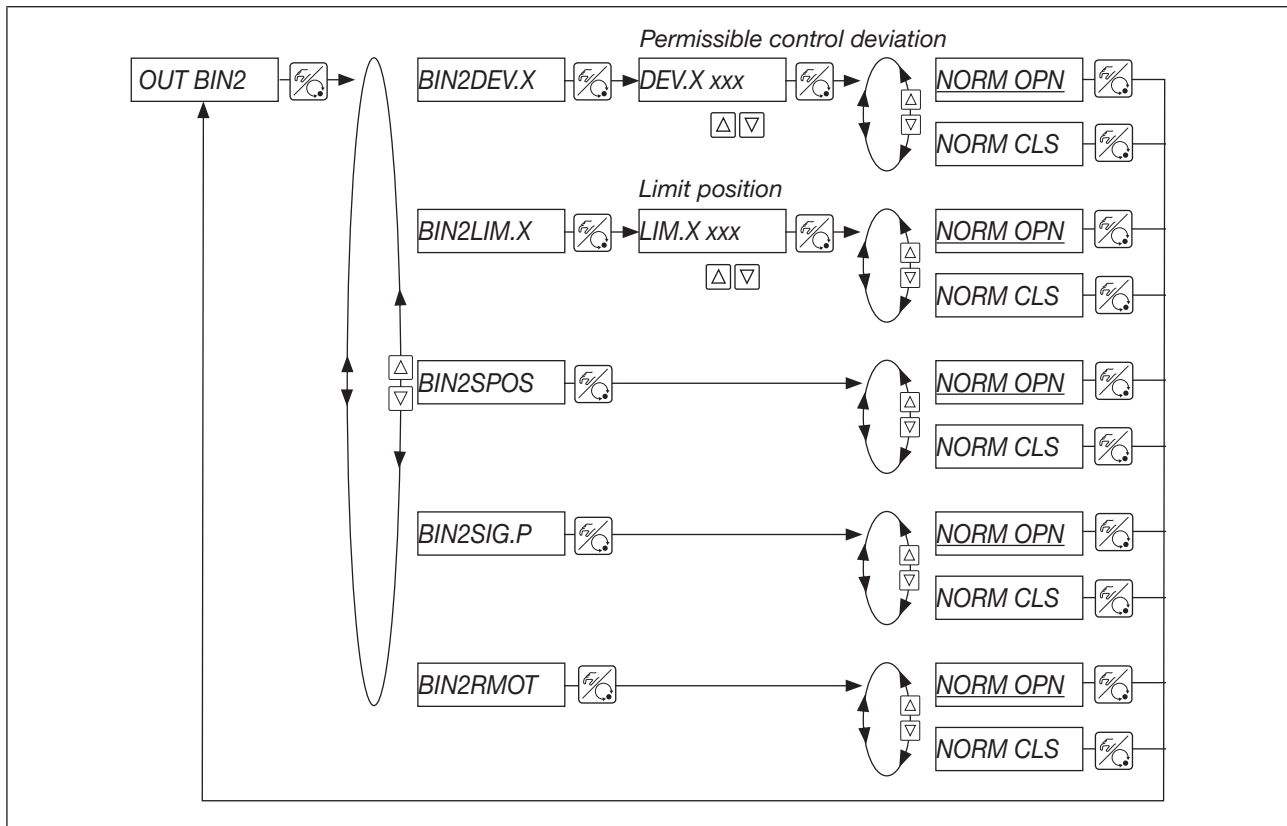

NORM OPN: “Normally Open” (NO) – output in switched state high (>2.1 mA)

NORM CLS: “Normally Closed” (NC) – output in switched state low (<1.2 mA)

Selection options:

BIN2DEV.X

Alarm output for excessive control deviation of the positioner.
The permissible control deviation *DEV.X xxx* must not be less than the dead band.

BIN2LIM.X

Digital position output
LIM.X xxx = limit position

OUT BIN1	NORM OPN	NORM CLS
POS > LIM	<1.2 mA	>2.1 mA
POS < LIM	>2.1 mA	<1.2 mA

BIN2SPOS

Actuator in safety position

BIN2SIG.P

Error message, signal actual position

BIN2RMOT

AUTOMATIC operating state and *external set-point value* active

19.16 CAL.USER: Changes to the factory calibration through the user

This function can be used by the user to change pre-calibrated factory settings of the valve position and of the standard signal values for actual value and set-point value.

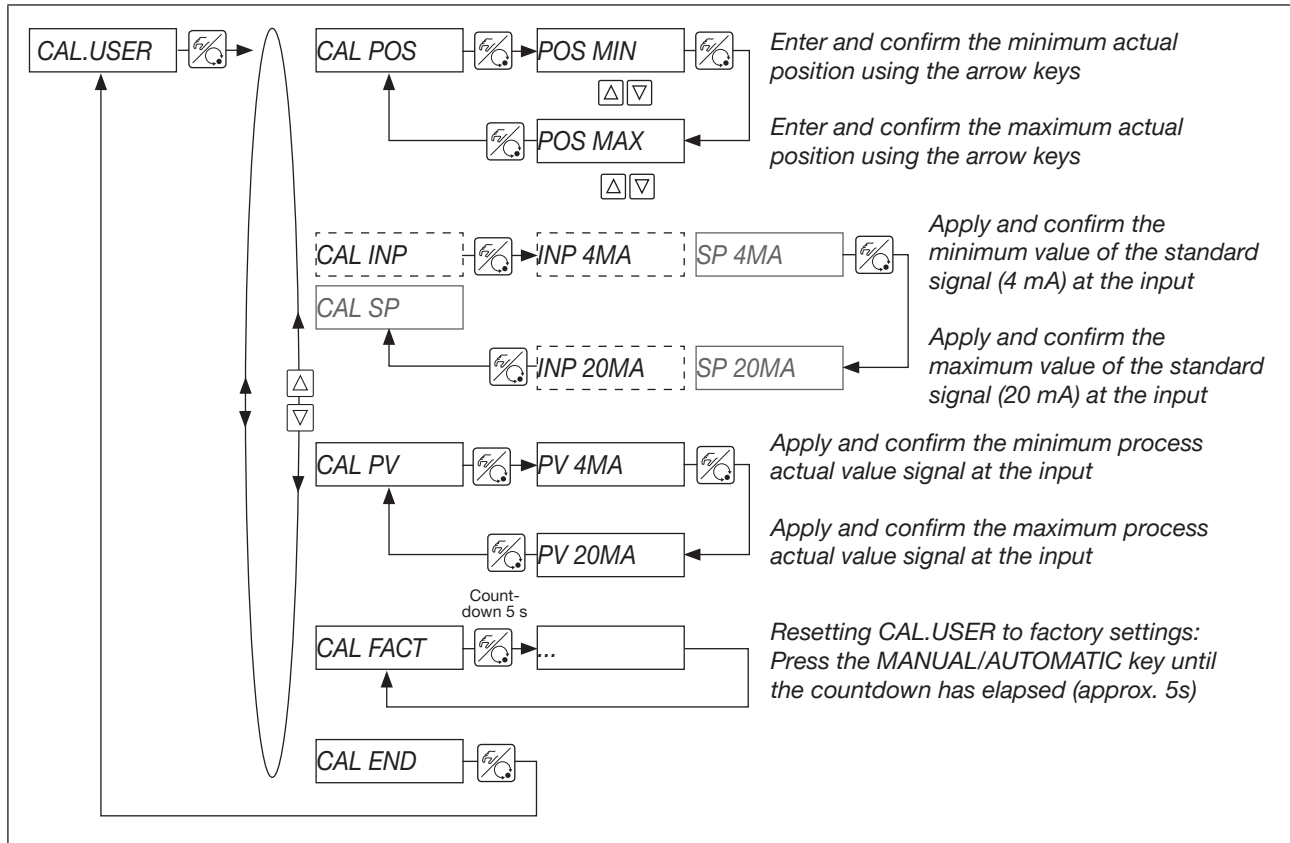

! Menu options shown in grey are only available for devices with the “process controller” option. Menu options shown with a dashed line are only available for devices without the “process controller” option.

Setting options:

- CAL.POS Calibrate actual position (0...100%)
- CAL.INP Calibrate set-point position (4...20 mA)
- CAL.SP Calibrate process set-point value (4...20 mA)
Menu option is not shown for internal set-point value!
- CAL.PV Calibrate process actual value (4...20 mA)
- CAL.FACT Resetting CAL.USER to factory settings

19.17 SET.FACT: Factory reset

With this auxiliary function, all settings made by the user are reset to the factory settings.

A device restart is then carried out automatically.



20 START-UP AS POSITIONER



DANGER

Risk of injury due to improper operation.

- ▶ Only authorised technicians may start up the device or system.



Establish the pneumatic connection ([Page 38](#)) and the electrical connection ([Page 39](#)) before start-up.

Carry out the following base settings during initial start-up:

- Setting the effective direction of the pressurisation state of the valve actuator to the actual position (see section “[19.4](#)” on [page 58](#))
- Carry out the X.TUNE function (AUTOTUNE) (see section “[20.1](#)” on [page 78](#))

When starting up the SideControl, the execution of *X.TUNE* is absolutely essential. In this case, the SideControl Type 8635 automatically determines the optimum settings for the valve used and the current operating conditions (supply pressure).

The following actions are initiated automatically by the *X.TUNE* function:

- Adaptation of the sensor signal to the (physical) stroke of the valve used.
- Determination of the parameters for controlling the integrated piezoelectric actuating system
- Adjustment of the control parameters of the SideControl
Optimisation is carried out according to the criteria of the shortest possible settling time and freedom from overshoot.

If, during the execution of *X.TUNE*, the *X.CONTRL* auxiliary function is in the main menu, the positioner dead band *X.CO DBND* is also determined automatically depending on the friction behaviour of the actuator (see section *X.CONTRL*).

NOTE

Faulty adjustments of the controller.

Pressure variations in the valve or changed supply pressure (= pneumatic auxiliary power) may cause faulty adjustment of the controller.

- ▶ Carry out the X.TUNE function with the valve unpressurised or shut off.
- ▶ Set the supply pressure (pneumatic auxiliary power) to the value that will exist in later operation.

20.1 Carry out the X.TUNE function (AUTOTUNE)

This function is used by the device automatically to determine the end positions (physical stroke) of the control valve.

! For armatures that do not have a physical end stop (e.g. continuously turning butterfly valves), the end positions must be manually preset by means of *TUNE-POS* before the AUTOTUNE (see section “20.2.1”).

! DANGER

Risk of injury due to uncontrolled movement of the control valve.

When carrying out the X.TUNE function, the controlled control valve automatically moves from its current position.

- ▶ Do not carry out the X.TUNE function when a process is running.
- ▶ Secure the device or system against unintentional activation.

! DANGER

Risk of injury due to uncontrolled process after carrying out the X.TUNE function.

Faulty adjustment of the controller may occur if the operating pressure is applied to the valve seat or if the pilot pressure is incorrect.

- ▶ Carry out the X.TUNE function at the pilot pressure that is available in later operation.
- ▶ Carry out the X.TUNE function without operating pressure to exclude disturbances resulting from flow forces.

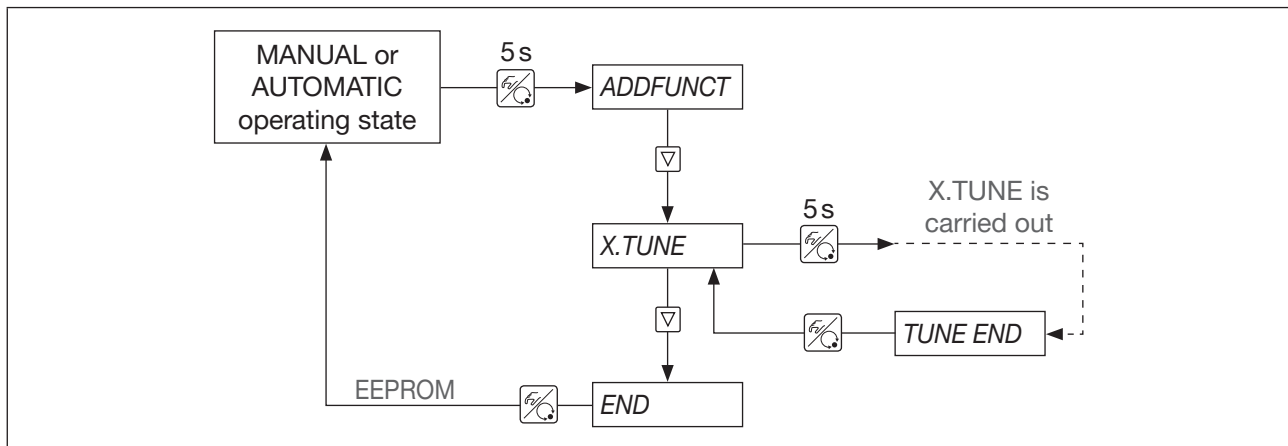

Figure 55: Operating structure of the “X.TUNE” basic function

Carrying out X.TUNE:







Key	Action	Display shows	Result
	press for approx. 5 s	<i>ADDFUNCT</i>	Toggling from process level to setting level
	press briefly	<i>X.TUNE</i>	X.TUNE function can be started
	press for approx. 5 s	<i>TUNE 5...TUNE 0</i> ! <i>X.T INIT</i> ! <i>X.T A1-P</i> ! <i>X.T TOPN</i> ! <i>X.T TCLS</i> <i>TUNE END</i> (flashes) or <i>X.ERR X</i>	Once the countdown has elapsed, automatic self-parameterisation starts Display of the currently running X.TUNE phases. The progress is indicated by a rotating bar at the left edge of the display. <i>X.TUNE</i> has been carried out Error message Last digit to the right shows the error number (for the error description, see section “22 Maintenance and troubleshooting” on page 87)
	press briefly	<i>X.TUNE</i>	The determined values are saved
	press briefly	<i>END XX</i>	Display changes to the menu option <i>END</i> . The software version is shown on the right of the display (<i>END XX</i>).
	press briefly	<i>EEPROM</i>	Saving the settings. When saving, the display shows <i>EEPROM</i> for approx. 3...5 s. Afterwards, the device returns to the operating state it was in before carrying out the X.TUNE function (MANUAL or AUTOMATIC).

Figure 56: Carry out the X.TUNE function (AUTOTUNE)

20.2 X.TUNE function - manual TUNE

The AUTOTUNE function automatically determines the end positions of the control valve on the basis of the physical stops. Certain armatures (e.g. continuously turning butterfly valves) do not have a physical end stop, so that the end positions must be manually preset by means of the menu option *TUNE-POS*. The menu option *TUNE-POS* is part of the manual TUNE.

! If manual presetting of the end positions using *TUNE-POS* is necessary, you must do this before carrying out AUTOTUNE.

You can access the manual TUNE functions by selecting *X.TUNE* in the main menu and briefly pressing the MANUAL/AUTOMATIC key or by releasing the MANUAL/AUTOMATIC key when aborting the countdown.

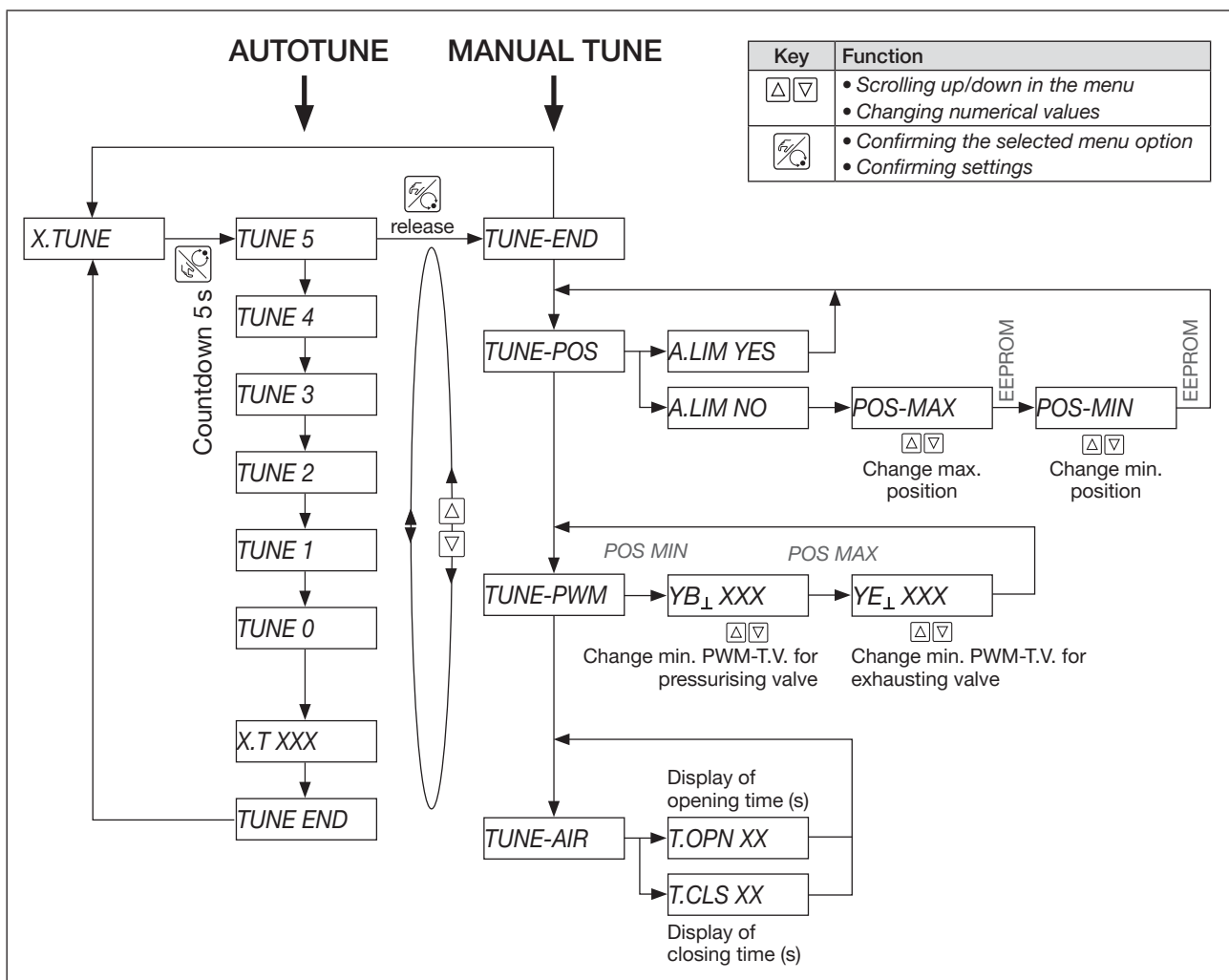

Figure 57: Operating structure of the "X.Tune - carry out manual TUNE" basic function

20.2.1 Description of the menus of the manual TUNE

TUNE-END

Return to the main menu

TUNE-POS

Presetting end positions

The end positions of the controlled control valve are manually preset by means of TUNE-POS. An immediately following AUTOTUNE assumes the manual end position settings and continues with setting the actuating system and optimisation of the positioner.



Carry out manual presetting of the end positions using *TUNE-POS* **before** AUTOTUNE.

TUNE-PWM

Optimising PWM pulse-duty factor

The AUTOTUNE function automatically determines the minimum required PWM pulse-duty factor for controlling the piezoelectric valves integrated in the SideControl. These values may deviate from the optimum because of unfavourable friction behaviour of the actuator. Using TUNE-PWM, it is possible to readjust it such that the lowest possible speed results for both directions of movement.



Carry out the *TUNE-PWM* **function after** AUTOTUNE.

TUNE-AIR

Adjusting opening and closing times

The required maximum air flow capacity of the internal actuating system depends on the volume of the actuator. Ideal control behaviour is obtained with an air flow capacity that leads to an opening or closing time of the armature of 1...2 s. For this reason, the SideControl is equipped with a throttle screw to vary the maximum air flow capacity of the internal actuating system.

The position of the throttle screw can be seen in "[Figure 1: Structure of the SideControl Type 8635](#)" on page 10. Adjustment of this throttle screw is carried out by means of TUNE-AIR, wherein the corresponding runtimes are determined by cyclic opening and closing of the valve and shown on the display.



Carry out the TUNE-AIR **function after** AUTOTUNE.

21 START-UP AS PROCESS CONTROLLER

 Only applies to devices with the “process controller” option.

Factory settings of the *P.CONTRL* function

<i>P.CO DBND</i>	1%
<i>P.CO PARA</i>	
<i>KP</i>	1.00
<i>TN</i>	000.9
<i>TV</i>	0.0
<i>X0</i>	0
<i>P.CO SETP</i>	<i>SETP INT</i>
<i>P.CO FILT</i>	0
<i>P.CO SCAL</i>	<i>PV</i> _↓ 000.0, <i>PV</i> _↑ 100.0
<i>P.CO TUNE</i>	<i>D'ACT</i>

21.1 Sequence of the work steps

The steps described below are necessary to operate the SideControl Type 8635 as a process controller.

 Always observe the sequence of the work steps during start-up.

1. Carry out the *X.TUNE* basic function (see “20.1” on page 78).
2. Enable the *P.CONTRL* auxiliary function (see “18.5” on page 50).
When enabling the *P.CONTRL* auxiliary function, the *P.Q'LIN* function is automatically copied to the main menu.
3. In *P.CONTRL*, carry out the base settings (see “19.9” on page 63):
Carry out the base settings for the process controller under *P.CONTRL* in the following submenus:
P.CO DBND
P.CO PARA
P.CO SETP
P.CO FILT
P.CO SCAL
4. Linearisation of the process characteristic (see “19.10” on page 67).
Initiate linearisation of the process characteristic with *P.Q'LIN*
5. Self-optimisation of the process controller (see “21.2” on page 83)
Now carry out self-optimisation of the process controller with *P.CO TUNE*.

21.2 P.TUNE: Carrying out self-optimisation of the process controller



When setting up the process control, be sure to follow the work steps as described in section [“21.1”](#) on page 82.

SideControl Type 8635 is a positioner which if required can be supplemented by a superimposed process controller (see section [“5.6”](#) on page 16).

The positioner controls the position of the control valve to the desired set-point position and is automatically parametrised and optimised by the X.TUNE basic function.

The superimposed process controller, which together with a sensor forms a process control loop, controls any measured variable. It has a PID structure whose components may be combined in various ways (P, PI, PD, PID), and freely parametrised (KP, TN, TV).

In order to obtain good control behaviour, the structure of the controller must be adapted to the characteristics of the process (control loop). The parameters must be selected to obtain a short setting time, a small overshoot width and good damping.

Parametrisation demands experience in control techniques, measuring equipment and is time consuming. For this reason, SideControl features the *P.TUNE* self-optimisation function. This function provides unique, direct determination of the parameters which can be read out as needed and modified in any way desired.

Mode of operating

During start-up of the control system, the process is excited by a set-point step in a closed control loop. This set-point step is carried out within the future working range of the process control system and serves to determine characteristic variables of the process.

Calculation of the PID parameters is carried out on the basis of these characteristic variables using a modified Ziegler-Nichols procedure.

21.2.1 Carrying out self-optimisation

! All the work steps for carrying out self-optimisation are executed on site via the operating elements of the SideControl Type 8635.

The following steps are necessary to carry out self-optimisation:

1. Activating the process tune
2. Making process tune ready to start
3. Adapting the start value for optimisation step (optional)
4. Initiating process tune

The 4 work steps are described below.

1. Activating the process tune

- Use the *P.TUN ACT* menu to activate self-optimisation of the process controller.
- Select the process type that corresponds to your control job.
With an unknown process, select *P.TYPN.DEF* (not defined).
- Change to the process level. To do so, exit the setting level via the menu option *END X.XX*.
- Switch the device to AUTOMATIC operating state (see section “15.1” on page 43).

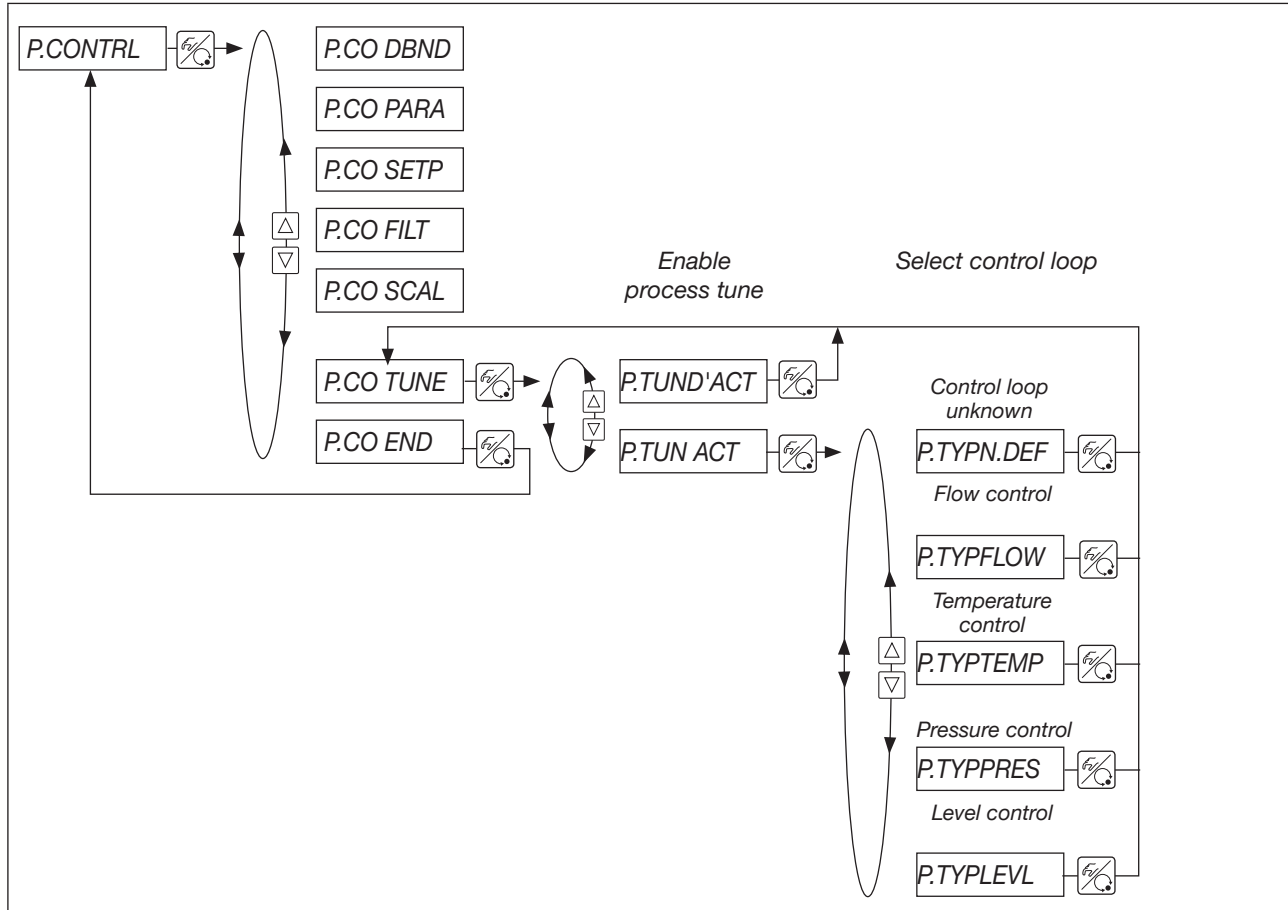

2. Making process tune ready to start

You are at process level, in AUTOMATIC operating state.

→ Make the process tune ready to start by means of the operating sequence shown in the following figure.

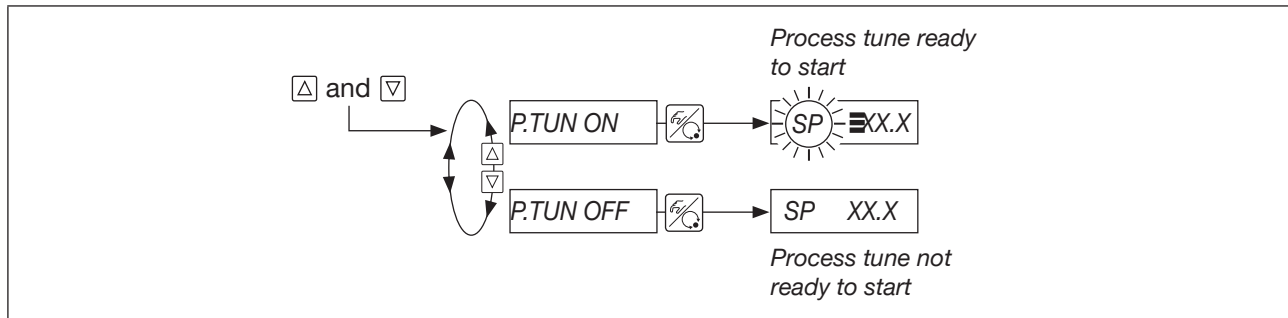

Figure 58: Operating sequence “Making process tune ready to start”, process level, AUTOMATIC operating state

The next set-point step entered via the keyboard (see work step 4) is now used for parameter optimisation. The process set-point value *SP* is set equal to the current sensor measured value *PV* and is the start value for the optimisation step.

Adaptation/Modification of this start value is described in step 3.

The readiness of process tune is symbolised in the display by three horizontal bars behind the flashing set-point symbol *SP*.

3. Adapting the start value for optimisation step (optional)

If required, the start value can be adapted for the optimisation step.

- Switch the device to MANUAL operating state.
- Open or close the process valve by pressing the arrow keys.
This causes a change in the process actual value *PV*.
- Press the arrow keys until the desired start value has been set.
- Switch the device to AUTOMATIC operating state.

4. Initiating process tune

You are at process level, in AUTOMATIC operating state.

While *P.TUNE* is running, it is possible to simultaneously press both arrow keys to stop the sequence. The selection *P.TUN RUN* or *P.TUN BRK* then appears. Use *RUN* and *BRK* to continue and abort the sequence respectively.

- Enter a set-point step via the keyboard. This step should take place in the future working range of the process control system.

The operating sequence in section “21.3” on page 86” describes the procedure.



The set-point step for parameter optimisation must always be entered via the operating keyboard. This also applies when the *P.CONTRL* / *P.CO SETP* / *SETP EXT* function (set-point value setting default via analogue input) has been specified during configuration. In this case, the external set-point value setting default is re-enabled only after completion of process tune.

Self-optimisation of the process controller is now performed automatically. The display shows a rotating bar and the message *P.TUNE*.

After completion of process tune, the device is in AUTOMATIC operating state. The process controller works from this point on with the optimised PID parameters and controls to the current internal or external set-point value SP.





To carry out a new optimisation cycle, repeat work steps 2...4.



Process tune in the operating menu of the device remains enabled, so that the process control is carried out with the set-point modulator (filter) in order to reduce unwanted, nonlinear effects.

If control is to be carried out without the set-point modulator, process tune must be disabled in the operating menu: *P.CONTRL / P.CO TUNE / P. TUN D'ACT*

21.3 Manual changing of the process set-point value

 or  > 3s	<p>With the display SP (set-point) set, press one of the two arrow keys for longer than 3 seconds to enable the mode for changing the process set-point value.</p> <p>After releasing the key, the first position of the process set-point value flashes</p>
 or 	<p>Use one of the two arrow keys to set the flashing position of the process set-point value.</p>
	<p>Confirm the value set and move to the next position.</p> <p>After confirmation of the fourth position, the process set-point value set is stored as the end value of the set-point step.</p>

22 MAINTENANCE AND TROUBLESHOOTING



WARNING

Risk of injury due to improper work on the device.

- ▶ Work on the device may be carried out only by trained specialist technicians using appropriate tools.
- ▶ Secure the system and actuators against unintentional activation.
- ▶ After working on the device, ensure a controlled restart.

22.1 Maintenance

If the instructions in this manual are followed during operation, the device is maintenance free.

22.2 Error messages, position control

Error messages when carrying out the X.TUNE function

Display	Causes of error	Remedy
X.ERR 1	No compressed air connected	Connect compressed air
X.ERR 2	Loss of compressed air when carrying out the X.TUNE function	Check compressed air supply
X.ERR 3	Actuator leaking or actuating system leaking on exhausting side	Remedy not possible, device defective
X.ERR 4	Control system, pressurising side leaking	Remedy not possible, device defective
X.ERR 5	The angular range of the position sensor is exceeded by 180°.	Correct attachment of the position sensor shaft on the actuator (see section "9" on page 29)
X.ERR 6	The end positions (POS-MIN and POS-MAX) are too close together	Check whether allocation of the end positions to POS-MIN and POS-MAX via the TUNE-POS function is correct If it is not correct: Carry out TUNE-POS again If it is correct: TUNE-POS not possible with this arrangement of the end positions as they are too close together
X.ERR 7	Incorrect allocation of POS-MIN and POS-MAX	To determine POS-MIN and POS-MAX, move the actuator in the direction shown on the display (see section "20.2" on page 80).

Table 9: Error messages when carrying out the X.TUNE function for position control

Other faults

Problem	Possible cause	Remedy
<i>POS = 0 (for CMD > 0%) or POS = 100% (for CMD < 100%)</i>	Sealing function (CUTOFF) has been unintentionally enabled	Disable sealing function

Table 10: *Other faults for position control*

22.3 Error messages, process control

General error messages

Display	Causes of error	Remedy
PV FAULT	Signal error, actual value, process controller	Check signal

Table 11: General error messages for process control

Error messages for P.Q'LIN function (linearisation of the process characteristic)

Display	Causes of error	Remedy
Q.ERR 1	No supply pressure connected	Connect supply pressure
	No change to measured variable	Check process, switch on pump if necessary or open shut-off valve
Q.ERR 2	Current supporting point of the valve stroke was not reached Possible causes: <ul style="list-style-type: none"> • Supply pressure failed during P.Q'LIN • X.TUNE function was not carried out 	Check supply pressure Carry out the X.TUNE function (see section "20.1" on page 78)

Table 12: Error messages for P.Q'LIN function (linearisation of the process characteristic)

Other faults

Problem	Possible cause	Remedy
$POS = 0$ (for $CMD > 0\%$) or $POS = 100\%$ (for $CMD < 100\%$) $PV = 0$ (for $SP > 0$) or $PV = PV_{\perp}$ (for $SP > SP_{\perp}$)	Sealing function (CUTOFF) has been unintentionally enabled	Disable sealing function (CUTOFF) (see section "18.5" on page 50)
Only for devices with process controller Device does not operate as positioner despite correct settings	The P.CONTRL auxiliary function has been enabled and is part of the main menu. The device thus operates as a process controller and expects a process actual value at the corresponding input	Disable the P.CONTRL auxiliary function (see section "18.5" on page 50)

Table 13: Other faults for process control

23 ACCESSORIES

Accessories	Order number
Attachment kit for linear actuators	787215
Attachment kit for rotary actuators	787338
Attachment kit for Remote position sensor (for control valves Type 23xx, actuator size Ø 70 mm, 90 mm + 130 mm)	584363
Assembly bridge for attachment to rotary actuators	770294
Mounting bracket (VA) for wall mounting (spare part)	675715

Table 14: Accessories

24 PACKAGING, TRANSPORT

NOTE

Transport damage.

Inadequately protected devices may be damaged during transport.

- ▶ Protect the device against moisture and dirt in shock-resistant packaging during transportation.
- ▶ Avoid exceeding or undercutting the permitted storage temperature.

25 STORAGE

NOTE

Incorrect storage may damage the device.

Permitted storage temperature: -20...+65 °C.

- ▶ Store the device in a dry and dust-free location.

26 DISPOSAL

→ Dispose of the device and the packaging in an environmentally friendly manner.

NOTE

Damage to the environment caused by device parts contaminated with media.

- ▶ Observe applicable disposal and environmental regulations.



Observe national waste disposal regulations.

27 ADDITIONAL INFORMATION

27.1 Selection criteria for control valves

The following criteria are decisive for optimum control behaviour and achieving the desired maximum flow rate:

- The correct choice of flow coefficient, which is essentially defined by the seat size of the valve;
- Good adjustment of the valve seat size to the pressure conditions, taking into account the other flow resistances in the system.

Dimensioning guidelines can be given on the basis of the flow coefficient (k_v value). The k_v value refers to the standardised conditions with respect to pressure, temperature and media properties.

The k_v value is defined as the flow rate of water through a component in m^3/h at a pressure difference of $\Delta p = 1$ bar and at $T = 20$ °C. The “ k_{vS} value” is additionally used with control valves. This specifies the k_v value when the control valve is fully open.

Depending on the specified data, the following 2 cases must be distinguished when selecting a valve:

Case 1

The pressure values p_1 and p_2 **upstream and downstream of the valve**, at which the desired maximum flow rate Q_{max} is to be achieved, are known.

The required k_{vS} value is obtained from:

$$k_{vS} = Q_{max} \cdot \sqrt{\frac{\Delta p_0}{\Delta p}} \cdot \sqrt{\frac{\rho}{\rho_0}} \quad (1)$$

Figure 59: Equation 1

Where:

- k_{vS} is the flow coefficient of the control valve when fully open [m^3/h]
- Q_{max} is the maximum volumetric flow rate [m^3/h]
- $\Delta p_0 = 1$ bar; pressure drop at the valve as in the definition of the k_v value
- $\rho_0 = 1000$ kg/m^3 ; density of water (as in the definition of the k_v value)
- Δp is the pressure drop at the valve [bar]
- ρ is the density of the medium [kg/m^3]

Case 2

The pressure values p_1 and p_2 **at the input and output of the overall system**, at which the desired maximum flow rate Q_{max} is to be achieved, are known.

1. step: Calculate the flow coefficient of the overall system k_{vtotal} according to equation 1.
2. step: Determine the flow rate through the system without the control valve (e.g. by short-circuiting the line at the valve installation site).
3. step: Calculate the flow coefficient of the system without the control valve (k_{vA}) according to equation 1.
4. step: Calculate the required k_{vS} value of the control valve according to equation 2:

$$k_{vS} = \sqrt{\frac{1}{\frac{1}{k_{vges}^2} - \frac{1}{k_{vA}^2}}} \quad (2)$$

Figure 60: Equation 2



The k_{VS} value of the control valve should have at least the value calculated from equation 1 or equation 2 relevant to the application, but under no circumstances should it be much greater.

The rule of thumb often used with switching valves, “somewhat larger never hurts”, can be very detrimental to the control behaviour of control valves.

Practice-oriented determination of the upper limit for the k_{VS} value is possible by means of the so-called valve authority Ψ :

$$\Psi = \frac{(\Delta p)_{v0}}{(\Delta p)_0} = \frac{k_{va}^2}{k_{va}^2 + k_{vs}^2}$$

Figure 61: Calculation of the valve authority Ψ

$(\Delta p)_{v0}$ pressure drop over the fully opened valve

$(\Delta p)_0$ pressure drop over the entire system



With a valve authority $\Psi < 0.3$, the control valve is over-dimensioned.

With the control valve fully open, the flow resistance is significantly smaller than that of the other fluidic components within the system. This means that only in the lower opening range does the valve position prevail in the operating characteristic. For this reason, the operating characteristic is strongly deformed.

By selecting a progressive (equipercetile) transfer characteristic between the set-point position and the valve stroke, this can be partially compensated and the operating characteristic linearised within certain limits. However, **the valve authority Ψ should be > 0.1 , even when using a correction characteristic.**

The control behaviour (control performance, setting time) when using a correction characteristic is strongly dependent on the operating point.

27.2 Properties of PID controllers

A PID controller has a proportional, an integral and a differential part (P, I and D parts).

27.2.1 P part

Function: $Y = K_p \cdot X_d$

K_p is the proportional action factor (amplification factor).

It is given by the ratio of the setting range ΔY to the proportional range ΔX_d .

Characteristic and step response of the P part of a PID controller

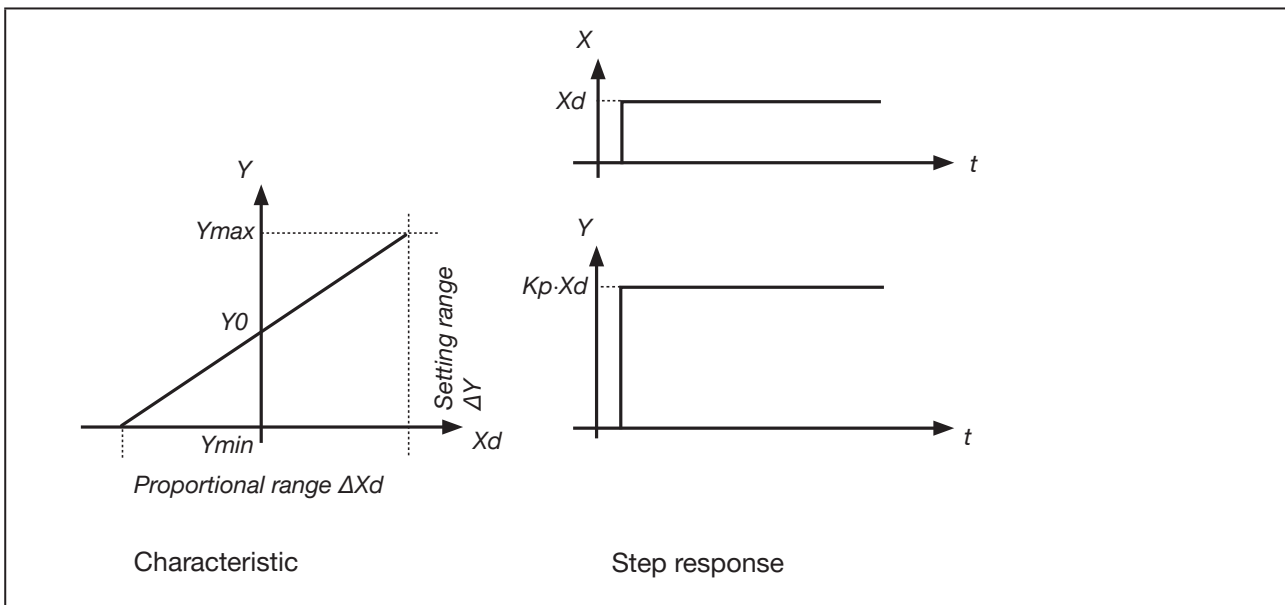

Figure 62: Characteristic and step response of the P part of a PID controller

Properties

A pure P controller works theoretically without delay. Meaning it is fast and dynamically favourable.

It has a residual control difference. This means it does not completely eliminate the effects of disturbances and is thus relatively unfavourable from a static viewpoint.

27.2.2 I part

$$\text{Function: } Y = \frac{1}{T_i} \int X_d dt$$

T_i is the integration or actuating time. T_i is the time that expires until the actuating variable has run through the entire setting range.

Characteristic and step response of the I part of a PID controller

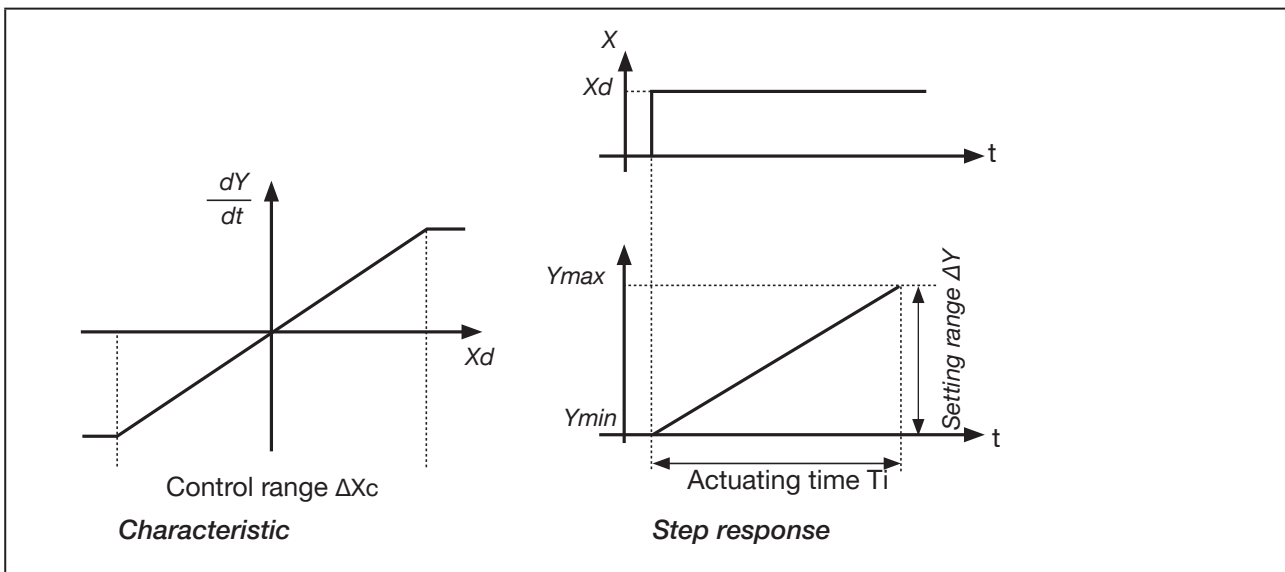

Figure 63: Characteristic and step response of the I part of a PID controller

Properties

A pure I controller completely eliminates the effects of disturbances. It thus has a favourable static behaviour.

Due to its finite control speed, it operates more slowly than a P controller and tends to oscillation. It is therefore dynamically relatively unfavourable.

27.2.3 D part

Function:

$$Y = K_d \cdot \frac{dX}{dt}$$

K_d is the differential action factor. The greater K_d , the stronger the D influence.

Characteristic and step response of the D part of a PID controller

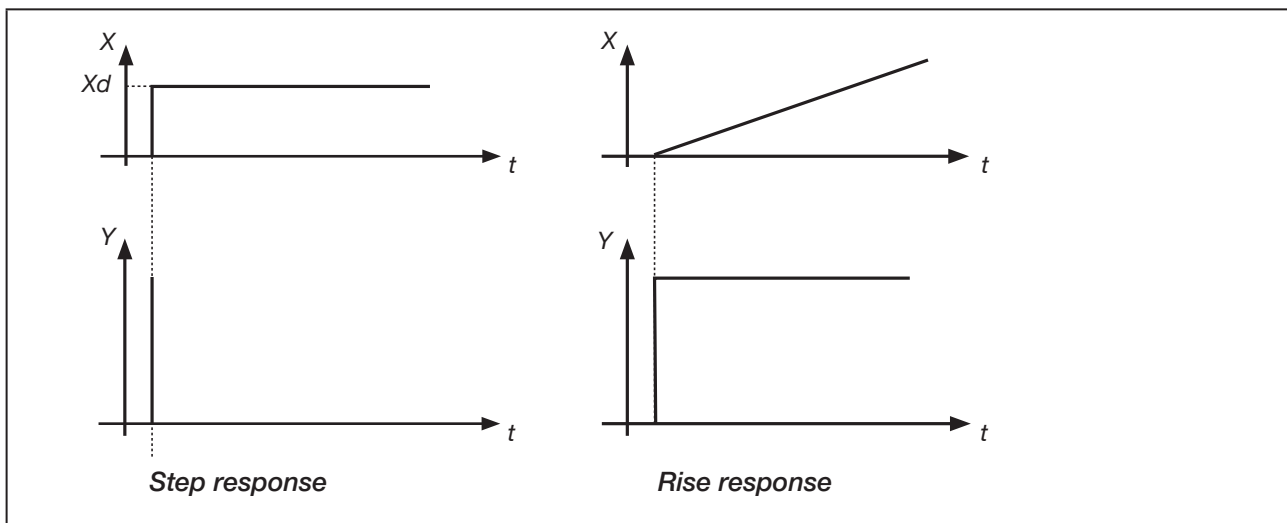

Figure 64: Characteristic and step response of the D part of a PID controller

Properties

A controller with a D part reacts to changes in the control variable and can thus reduce any control differences that occur more quickly.

27.2.4 Superimposing the P, I and D parts

Function:

$$Y = K_p \cdot X_d + \frac{1}{T_i} \int X_d dt + K_d \frac{dX_d}{dt}$$

With $K_p \cdot T_i = T_n$ and $K_d/K_p = T_v$, we obtain for the **function of the PID controller**:

$$Y = K_p \cdot \left(X_d + \frac{1}{T_n} \int X_d dt + T_v \frac{dX_d}{dt} \right)$$

K_p Proportional action factor / amplification factor

T_n Reset time
(the time required to obtain the same change in the actuating variable through the I part as was caused by the P part)

T_v Hold-back time
(the time by which a certain actuating variable is obtained earlier with the D part than with a pure P controller)

Step response and rise response of the PID controller

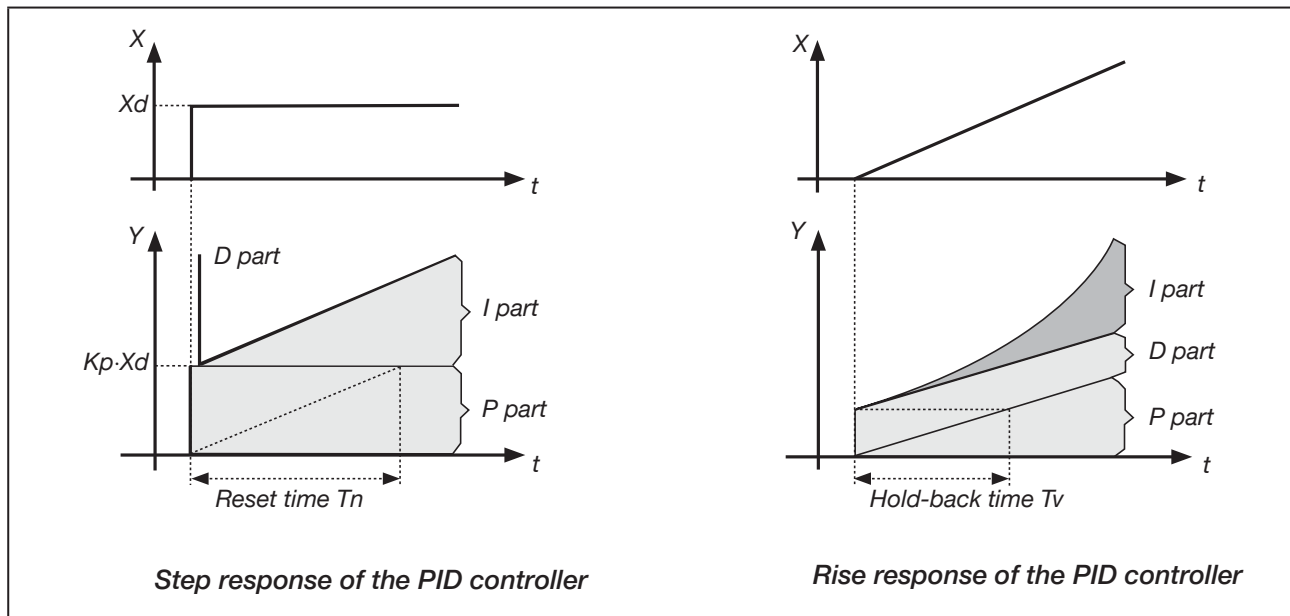

Figure 65: Characteristic, step response and rise response of the PID controller

MAN 1000011213 EN Version: L Status: RL (released | freigegeben) printed: 08.05.2026

27.2.5 Implemented PID controller

27.2.5.1 D part with delay

In the process controller of the SideControl Type 8635, the D part is implemented with a delay T.

Function:

$$T \cdot \frac{dY}{dt} + Y = K_d \cdot \frac{dX_d}{dt}$$

Superimposing the P, I and DT parts

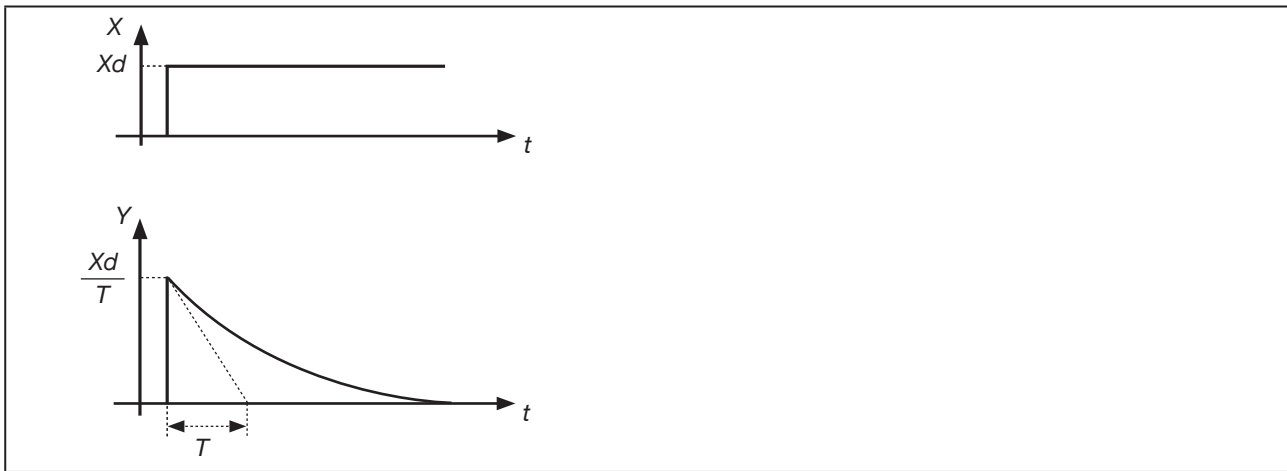

Figure 66: Superimposing the P, I and DT parts

27.2.5.2 Function of the real PID controller

$$T \cdot \frac{dY}{dt} + Y = K_p \left(X_d + \frac{1}{T_n} \int X_d dt + T_v \frac{dX_d}{dt} \right)$$

Step response of the real PID controller

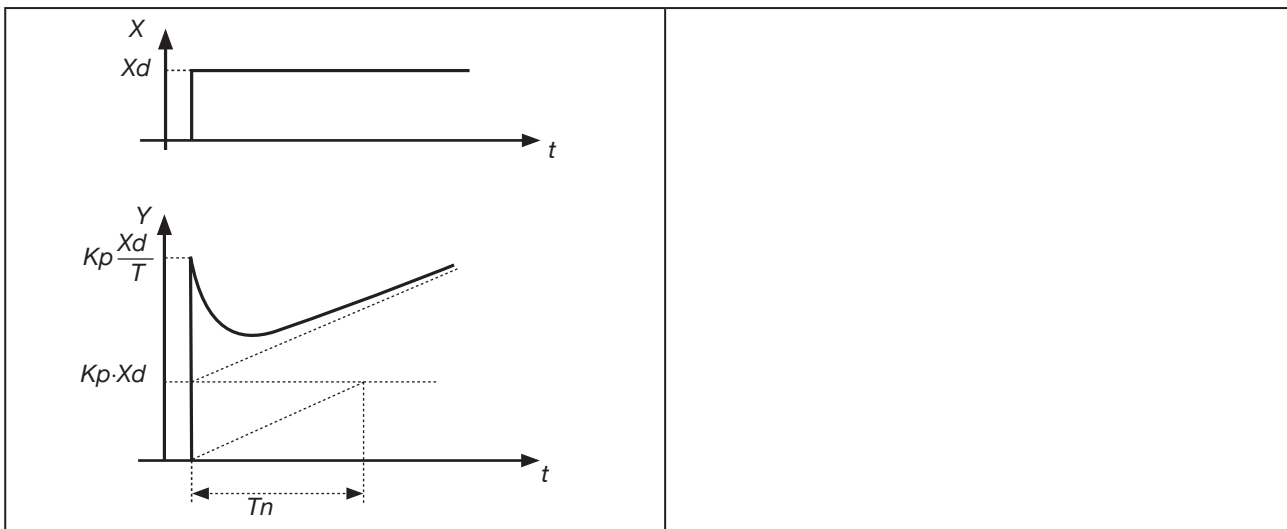

Figure 67: Characteristic, step response of the real PID controller

27.3 Rules for adjusting PID controllers

The control system Type 8635 is equipped with a self-optimisation function for the structure and parameters of the integrated process controller. The determined PID parameters can be viewed via the operating menu and empirically optimised as required.

The literature on control technology contains a number of rules which can be used to experimentally determine a favourable setting of the controller parameters. In order to avoid incorrect settings, the conditions under which the rules were set up in each case must be kept in mind. Apart from the properties of the control loop and the controller itself, it makes a difference whether a change in disturbance or a command variable is to be compensated.

27.3.1 Adjustment rules of Ziegler and Nichols (oscillation method)

With this method, the controller parameters are set on the basis of the behaviour of the control loop at the limit of stability. The control parameters are initially set such that the control loop begins to oscillate. Critical characteristic values occurring allow you to deduce a favourable setting of the control parameters. A prerequisite for using this method is naturally that the control loop is permitted to oscillate.

Procedure

- Set the controller to P controller ($T_n = 999$, $T_v = 0$), initially select a small K_p .
- Set the desired set-point value.
- Increase K_p until the control variable executes continuous undamped oscillation.

The proportional action factor (amplification factor) set at the limit of stability is designated K_{crit} . The resulting oscillation period is designated T_{crit} .

Curve of controller output at the limit of stability

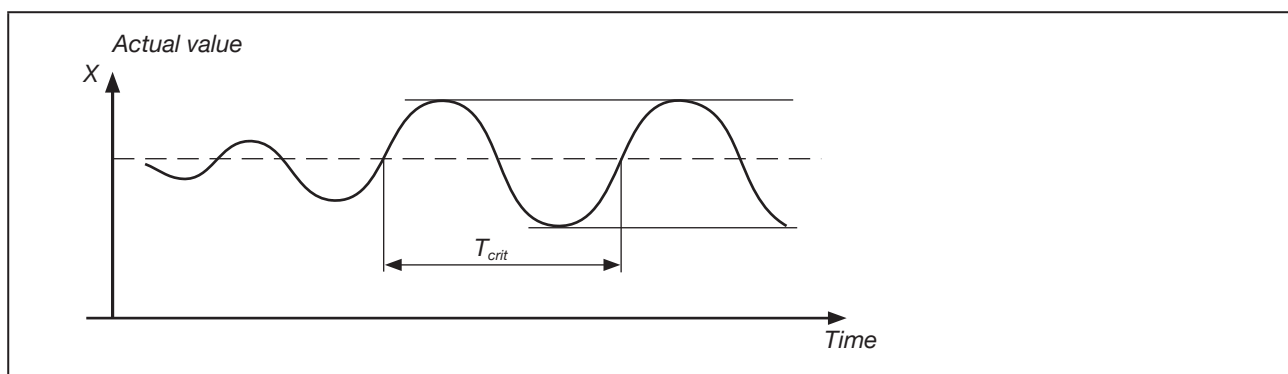

Figure 68: Course of the control variable PID

From K_{crit} and T_{crit} , the controller parameters can then be calculated using the following table.

Parameter setting according to Ziegler and Nichols

Controller type	Parameter setting		
P controller	$K_p = 0.5 K_{crit}$	-	-
PI controller	$K_p = 0.45 K_{crit}$	$T_n = 0.85 T_{crit}$	-
PID controller	$K_p = 0.6 K_{crit}$	$T_n = 0.5 T_{crit}$	$T_v = 0.12 T_{crit}$

Table 15: Parameter setting according to Ziegler and Nichols

The adjustment rules of Ziegler and Nichols have been determined for P loops with first order time delay and dead time. However, they apply only to controllers with disturbance behaviour and not for those with command behaviour.

27.3.2 Adjustment rules according to Chien, Hrones and Reswick (actuating variable step method)

With this method, the control parameters are set on the basis of the transient behaviour of the control loop. A step in the actuating variable of 100% is delivered. The times T_u and T_g are derived from the curve of the actual value of the control variable.

Curve of the control variable after a step in the actuating variable ΔY

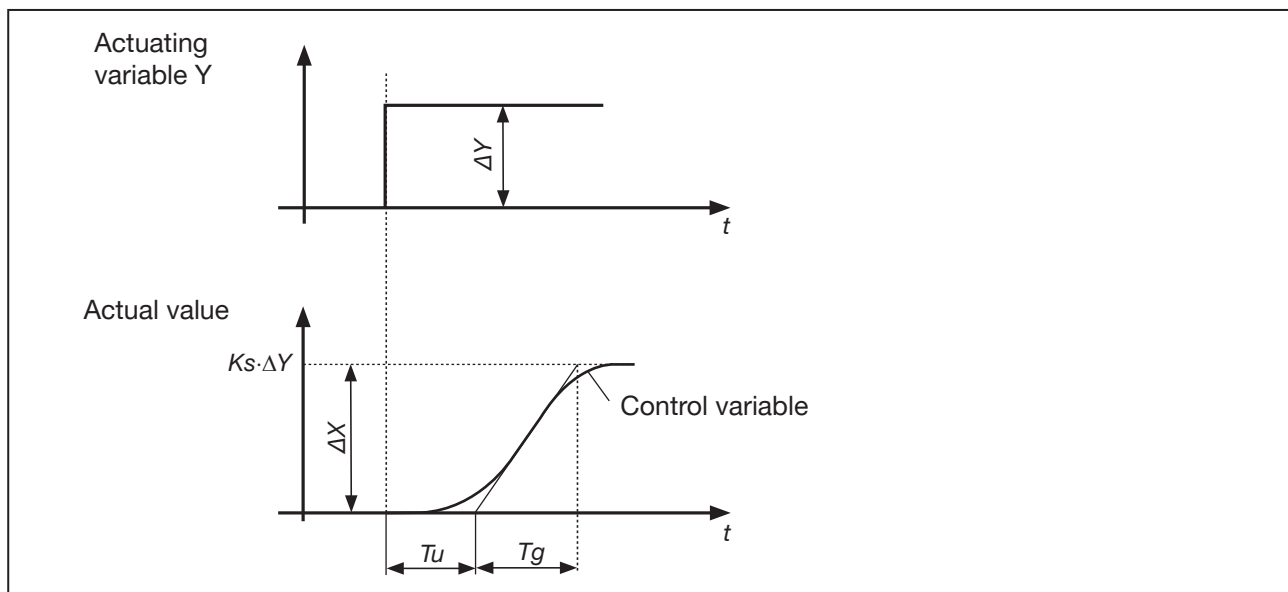

Figure 69: Curve of the control variable after a step in the actuating variable

Procedure

- Switch the controller to MANUAL operating state.
- Deliver a step in the actuating variable and record the control variable with a chart recorder.
- With critical curves (e.g. if there is a risk of overheating), switch off in good time.



Observe that with thermally sluggish systems the actual value of the control variable may continue to rise after switching off.

In the following table, the setting values are given for the control parameters as a function of T_u , T_g and K_s for command and disturbance behaviour, as well as for an aperiodic control event and a control event with 20% overshoot. They apply for loops with P behaviour, with dead time and with first order delay.

Parameter setting according to Chien, Hrones and Reswick

Controller type	Parameter setting			
	with aperiodic control event (0% overshoot)		with control event with 20% overshoot	
	Command	Disturbance	Command	Disturbance
P controller	$K_p = 0.3 \cdot \frac{T_g}{T_u \cdot K_s}$	$K_p = 0.3 \cdot \frac{T_g}{T_u \cdot K_s}$	$K_p = 0.7 \cdot \frac{T_g}{T_u \cdot K_s}$	$K_p = 0.7 \cdot \frac{T_g}{T_u \cdot K_s}$
PI controller	$K_p = 0.35 \cdot \frac{T_g}{T_u \cdot K_s}$ $T_n = 1.2 \cdot T_g$	$K_p = 0.6 \cdot \frac{T_g}{T_u \cdot K_s}$ $T_n = 4 \cdot T_u$	$K_p = 0.6 \cdot \frac{T_g}{T_u \cdot K_s}$ $T_n = T_g$	$K_p = 0.7 \cdot \frac{T_g}{T_u \cdot K_s}$ $T_n = 2.3 \cdot T_u$
PID controller	$K_p = 0.6 \cdot \frac{T_g}{T_u \cdot K_s}$ $T_n = T_g$ $T_v = 0.5 \cdot T_u$	$K_p = 0.95 \cdot \frac{T_g}{T_u \cdot K_s}$ $T_n = 2.4 \cdot T_u$ $T_v = 0.42 \cdot T_u$	$K_p = 0.95 \cdot \frac{T_g}{T_u \cdot K_s}$ $T_n = 1.35 \cdot T_g$ $T_v = 0.47 \cdot T_u$	$K_p = 1.2 \cdot \frac{T_g}{T_u \cdot K_s}$ $T_n = 2 \cdot T_u$ $T_v = 0.42 \cdot T_u$

Table 16: Parameter setting according to Chien, Hrones and Reswick

The proportional action factor K_s of the control loop is obtained from:

$$K_s = \frac{\Delta X}{\Delta Y}$$

28 MENU STRUCTURE OF THE SOFTWARE

ADDFUNCT	
*CHARACT	
CHA LIN	
CHA 1/25	
CHA 1/33	
CHA 1/50	
CHA 25/1	
CHA 33/1	
CHA 50/1	
CHA FREE	
0 xxx	
5 xxx	
100 xxx	
*CUTOFF	
CUT ₁ xx	
CUTT XXX	
*DIR.CMD	
DIR.CRISE	
DIR.CFALL	
*DIR.ACT	
DIR.ARISE	
DIR.AFALL	
*SPLTRNG	
SR ₁ xx	
SRT xxx	
*X.LIMIT	
LIM ₁ xx	
LIMIT xxx	
*X.TIME	
T.OPN xxx	
T.CLS xxx	
*X.CONTRL	
X.CO DBND	
DBND xx.x	
X.CO PARA	
KX ₁ xxx	
KXT xxx	
X.CO END	
*P.CONTRL	
P.CO DBND	
DBND xx.x	
P.CO PARA	
KP xx.xx	
TN xxx.x	
TV xxx.x	
X0 xxx	
P.CO SETP	
SETP INT	
SETP EXT	
P.CO FILT	
FILT xx.x	
P.CO SCAL	
DP x	
PV ₁ xx.xx	
PVT xx.xx	

					SP ₁ xx.xx
					SPT xx.xx
					P.CO TUNE
					P.TUN D'ACT
					P.TUN ACT
					P.TYPN.DEV
					P.TYPFLOW
					P.TYPTEMP
					P.TYPPRES
					P.TYPLEVL
					P.CO END
					*CODE
					CODE KEY
					CODExxx
					CODEMENU
					*SAFEPOS
					SPOS xxx (if SAFEPOS is inactive, then SPOS = 000)
					*SIG-ERR
					ERR.P INP
					P.INP OFF
					P.INP ON
					SPOS OFF
					SPOS ON
					ERR END
					*BIN-IN
					B.IN SPOS
					NORM OPN
					Norm CLS
					B.IN M/A
					NORM OPN
					NORM CLS
					*OUTPUT
					OUT ANL
					ANL POS
					ANL 4'20A
					ANL CMD
					ANL PV
					ANL SP
					OUT BIN1
					BIN1DEV.X
					DEV.X x.x
					NORM OPN
					NORM CLS
					BIN1LIM.X
					LIM.X xxx
					NORM OPN
					NORM CLS
					BIN1SPOS
					NORM OPN
					NORM CLS
					BIN1SIG.P
					NORM OPN
					NORM CLS
					BIN1RMOT

					NORM OPN
					NORM CLS
					OUT BIN2
					BIN2DEV.X
					DEV.X x.x
					NORM OPN
					NORM CLS
					BIN2LIM.X
					LIM.X xxx
					NORM OPN
					NORM CLS
					BIN2SPOS
					NORM OPN
					NORM CLS
					BIN2SIG.P
					NORM OPN
					NORM CLS
					BIN2RMOT
					NORM OPN
					NORM CLS
					OUT END
					*CAL.USER
					CAL.POS
					POS MIN
					POS MAX
					CAL INP (controller active)
					INP 4MA
					INP 20MA
					CAL SP (process controller active)
					SP 4MA
					SP 20MA
					CAL PV (process controller active)
					PV 4MA
					PV 20MA
					CAL FACT
					Countdown
					CAL END
					*SET.FACT
					Countdown
					ENDFUNCT
					X.TUNE
					X.TUNE x
					X.TUNEEND
					P.Q'LIN
					P.Q'LIN x
					P.Q'LINEND
					P.TUNE
					END xxx

29 APPENDIX

29.1 Settings of the freely programmable characteristic

Supporting point set-point value [%]	Valve stroke [%]			
	Date:	Date:	Date:	Date:
0				
5				
10				
15				
20				
25				
30				
35				
40				
45				
50				
55				
60				
65				
70				
75				
80				
85				
90				
95				
100				

MAN 1000011213 EN Version: L Status: RL (released | freigegeben) printed: 08.05.2026

29.2 Set process control parameters

	Date:	Date:	Date:	Date:
KP				
TN				
TV				
X0				
DBND				
DP				
PV ₁				
PV ^T				
SP ₁				
SPT				
UNIT				
KFAC				
FILT				
INP				