

* AT FULL DIFFERENTIAL PRESSURE FOR CLEAN FLUIDS WITH TFM1600 NON-CAVITY FILLED SEATS

SIZE	A	øB	C	øD	E1	E2	F	G	J1	J2	K	øL1	øL2	W	ISO 5211	WEIGHT (lbs)	Cv	TORQUE* (in-lbf)	BODY BOLT SIZE	BODY NUT SIZE
1/2"	0.21 (5)	1.0 (25)	0.64 (16)	0.37 (9)	5.50 (140)	3.50 (89)	5 (127)	2.22 (56)	0.22 (6)	0.37 (9)	M5-0.8	1.42 (36)	N/A	0.065 (1.7)	F03	2	8	60	M6 - 1.0 X 45	M6-1.0P
3/4"	0.21 (5)	1.0 (25)	0.64 (16)	0.62 (16)	6.00 (152)	4.00 (102)	5 (127)	2.28 (58)	0.22 (6)	0.37 (9)	M5-0.8	1.42 (36)	N/A	0.065 (1.7)	F03	2	29	60	M6-1.0 X 53	M6-1.0P
1"	0.33 (8)	1.2 (30)	0.72 (18)	0.87 (22)	6.50 (165)	4.50 (114)	6 (152)	2.56 (65)	0.30 (8)	0.43 (11)	M5-0.8	1.65 (42)	N/A	0.065 (1.7)	F04	4	66	100	M8 - 1.25 X 72	M8-1.25P
1-1/2"	0.43 (11)	1.4 (36)	1.16 (29)	1.37 (35)	7.50 (191)	5.50 (140)	7 (178)	3.09 (78)	0.34 (9)	0.56 (14)	M6-1.0	1.75 (44)	1.97 (50)	0.065 (1.7)	F05	8	192	200	M10-1.5 X 89	M10-1.5P
2"	0.43 (11)	1.4 (36)	1.16 (29)	1.87 (47)	8.00 (203)	6.25 (159)	7 (178)	3.45 (88)	0.34 (9)	0.56 (14)	M6-1.0	1.75 (44)	1.97 (50)	0.065 (1.7)	F05	13	434	250	M12-1.75 X 107	M12-1.75P

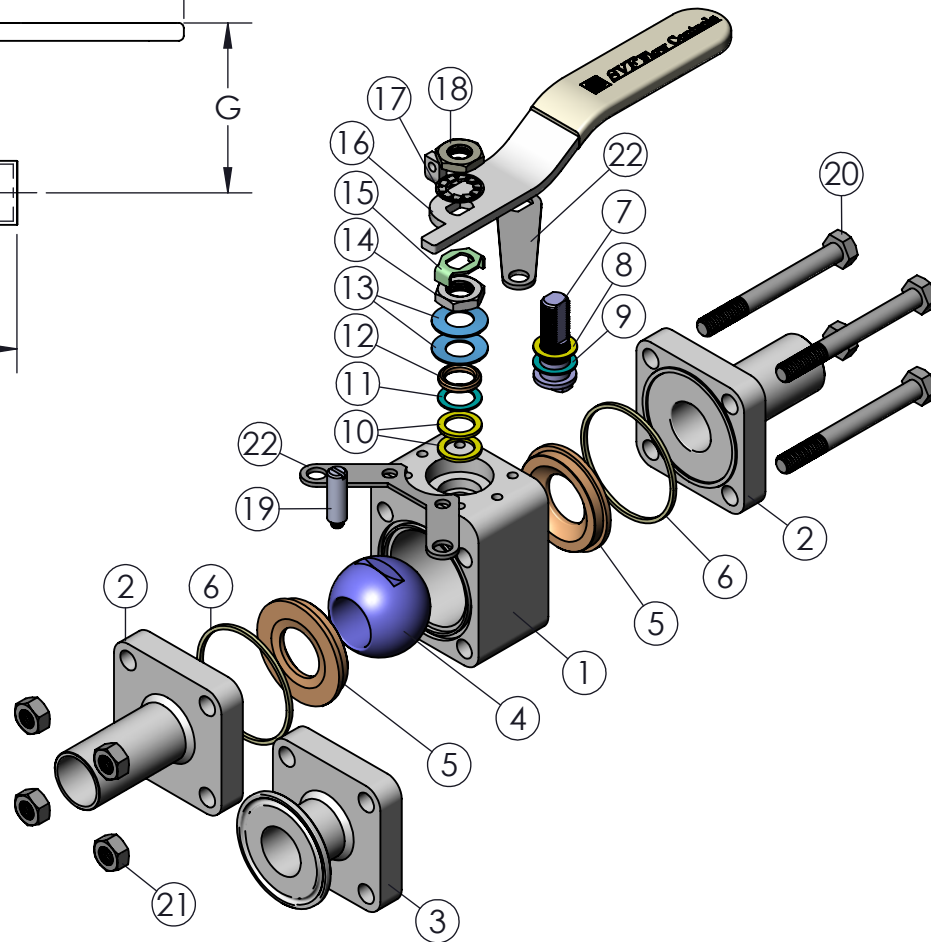
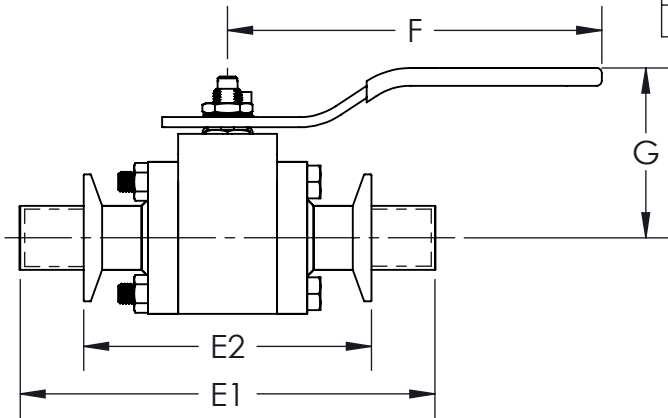

PRODUCT INFORMATION:

1. END CONNECTIONS AVAILABLE IN: TRI-CLAMP, EXTENDED TUBE-OD, TRI-CLAMP X EXTENDED TUBE-OD AND EXTENDED TUBE-OD X TRI-CLAMP
2. SERVICES INCLUDE: OXYGEN CLEANING, ELECTROPOLISH, HIGH CYCLE STEM KIT, AND VACUUM & SEARCHING GAS STEM KIT
3. SULFUR CONTENT OF 0.005-0.017% FOR WELD ENDS
4. CONTROLLED DELTA FERRITE CHEMISTRY
5. INTERNAL SURFACE FINISH OF 15 Ra OR BETTER
6. ALL STAINLESS STEEL PASSIVATED
7. COMPLETE VALVE AUTOMATION

OPTIONS:

1. OVAL HANDLE
2. LOCKING DEVICE
3. ISO STEM EXTENSION
4. ANTI-STATIC DEVICE

APPLICABLE STANDARDS:

1. ASME BPE: HYGIENIC
2. ASME B16.34: DESIGN
3. API 598: INSPECTION AND TESTING
4. ISO 5211: MOUNTING
5. CGA G-4.1: CLEANING FOR OXYGEN SERVICE
6. USP CLASS VI, SECTIONS 87 & 88: CONFIRMATION OF COMPLIANCE (TFM1600/PTFE MATERIAL)

ITEM NO.	DESCRIPTION	MATERIALS	QTY.
1	BODY	A182-F316L	1
2	ETO END	A182-F316L	2
3	TRI-CLAMP END	A182-F316L	2
4	BALL	A182-F316L	1
5	SEAT	TFM1600 CAVITY-FILLED TFM1600	2
6	BODY SEAL	TFM1600	2
7	STEM	A479-316L	1
8	STEM THRUST WASHER	TFM1600	1
9	STEM THRUST WASHER	VIRGIN PEEK	1
10	STEM SEAL	TFM1600	2
11	STEM SEAL	VIRGIN PEEK	1
12	GLAND FOLLOWER	304 STAINLESS STEEL	1
13	BELLEVILLE WASHER	301 STAINLESS STEEL	2
14	JAM NUT	304 STAINLESS STEEL	1
15	LOCK TAB	304 STAINLESS STEEL	1
16	LEVER HANDLE	304 STAINLESS STEEL	1
17	SERRATED LOCK WASHER	304 STAINLESS STEEL	1
18	HANDLE NUT	304 STAINLESS STEEL	1
19	STOP PIN	304 STAINLESS STEEL	1
20	BODY BOLT	304 STAINLESS STEEL	4
21	BODY NUT	304 STAINLESS STEEL	4
22	LOCKING DEVICE (OPTIONAL)	304 STAINLESS STEEL	2

END CONFIGURATIONS:

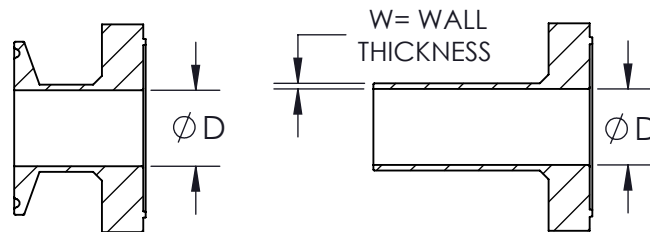

TRI-CLAMP END

EXTENDED TUBE-OD END

TOPWORKS

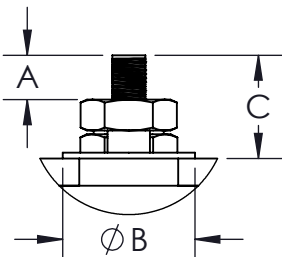

SIZES 1/2" - 1":

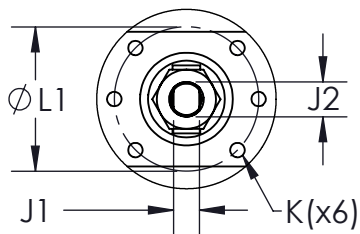

SIZES 1-1/2" - 2":

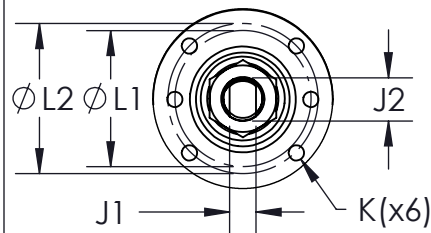

DRAWN BY E.P. DATE 04/05/2017
 CHECKED BY C.L. DATE 03/17/2021
 APPROVED BY J.S. DATE 03/17/2021

(FOR REF. ONLY IF NOT APPROVED)
 THE INFORMATION CONTAINED IN THIS DRAWING IS THE SOLE PROPERTY OF SVF FLOW CONTROLS, INC. ANY REPRODUCTION IN PART OR IN WHOLE WITHOUT THE WRITTEN CONSENT OF SVF FLOW CONTROLS, INC. IS PROHIBITED.

PROJECTION THIRD ANGLE



DESCRIPTION: 1/2" - 2" SB7F 3-PIECE CLEANFLOW HIGH PURITY FORGED BALL VALVE

UNITS: INCH (MILLIMETERS) DATE: 03/17/2021 REV: C

* AT FULL DIFFERENTIAL PRESSURE FOR CLEAN FLUIDS WITH TFM1600 NON-CAVITY FILLED SEATS

SIZE	A	øB	C	øD	E1	E2	F	G	J1	J2	K	L1	L2	øL3	W	ISO 5211	WEIGHT (lbs)	Cv	TORQUE* (in-lbf)	BODY BOLT SIZE	BODY NUT SIZE
2-1/2"	0.68 (17)	1.60 (41)	1.69 (43)	2.37 (60)	9.50 (241)	6.75 (171)	10 (254)	5.35 (136)	0.55 (14)	0.75 (19)	M8-1.25	2.76 (70)	1.26 (32)	2.76 (70)	0.065 (1.7)	F07	20	723	450	M10 - 1.5 X 30	N/A
3"	0.78 (20)	1.90 (48)	1.85 (47)	2.87 (73)	10.50 (267)	7.00 (178)	16 (406)	6.55 (166)	0.75 (19)	0.75 (19)	M10-1.5	3.37 (86)	1.75 (44)	4.02 (102)	0.065 (1.7)	F10	37	1124	1300	M10 - 1.5 X 30	N/A
4"	0.78 (20)	1.90 (48)	1.85 (47)	3.83 (97)	12.50 (318)	8.50 (216)	16 (406)	7.14 (181)	0.75 (19)	0.75 (19)	M10-1.5	3.37 (86)	1.75 (44)	4.02 (102)	0.083 (2.1)	F10	53	2100	1400	M12 - 1.75 X 30	N/A

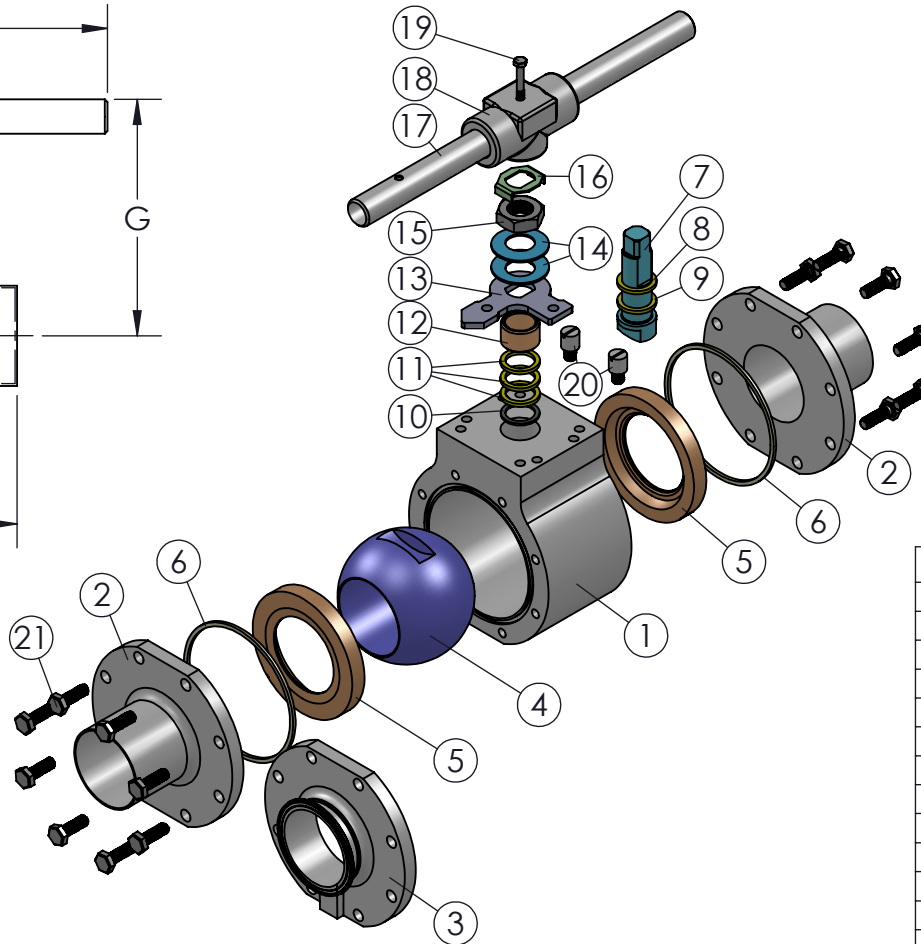
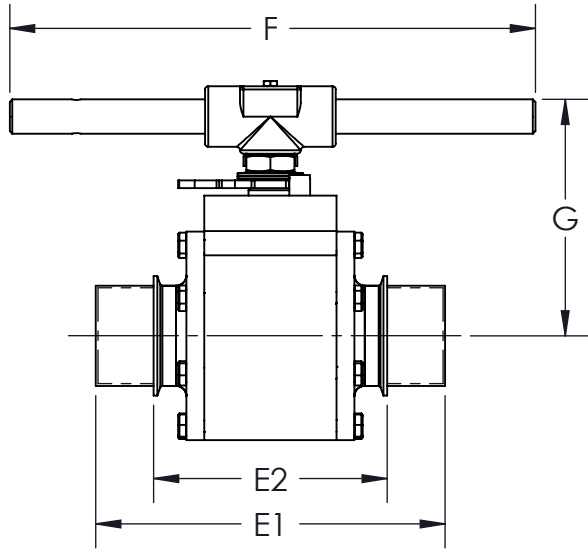

PRODUCT INFORMATION:
 1. END CONNECTIONS AVAILABLE IN: TRI-CLAMP, EXTENDED TUBE-OD, TRI-CLAMP X EXTENDED TUBE-OD AND EXTENDED TUBE-OD X TRI-CLAMP
 2. SERVICES INCLUDE: OXYGEN CLEANING, ELECTROPOLISH, HIGH CYCLE STEM KIT, AND VACUUM & SEARCHING GAS STEM KIT
 3. SULFUR CONTENT OF 0.005-0.017% FOR WELD ENDS
 4. CONTROLLED DELTA FERRITE CHEMISTRY
 5. INTERNAL SURFACE FINISH OF 15 Ra OR BETTER
 6. ALL STAINLESS STEEL PASSIVATED
 7. COMPLETE VALVE AUTOMATION

OPTIONS:
 1. LOCKING DEVICE
 2. ISO STEM EXTENSION
 3. ANTI-STATIC DEVICE

APPLICABLE STANDARDS:
 1. ASME BPE: HYGIENIC
 2. ASME B16.34: DESIGN
 3. API 598: INSPECTION AND TESTING
 4. ISO 5211: MOUNTING
 5. CGA G-4.1: CLEANING FOR OXYGEN SERVICE
 6. USP CLASS VI, SECTIONS 87 & 88: CONFIRMATION OF COMPLIANCE (TFM1600/PTEF MATERIAL)

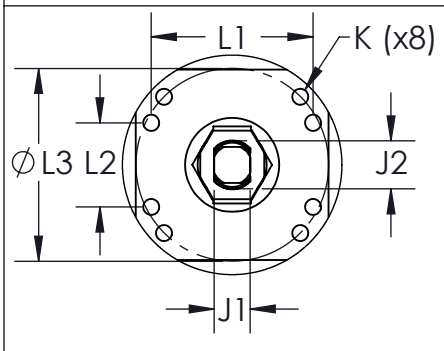
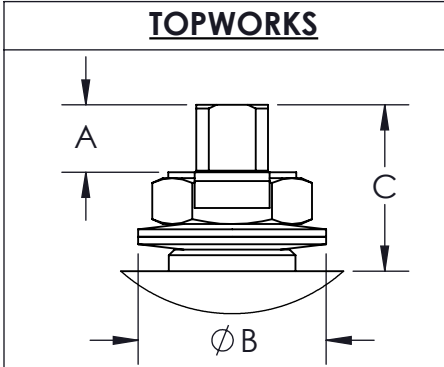

END CONFIGURATIONS:

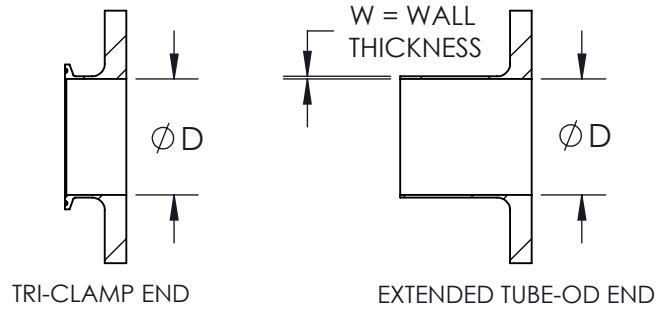

ITEM NO.	DESCRIPTION	MATERIALS	QTY.
1	BODY	A182-F316L	1
2	ETO END	A182-F316L	2
3	TRI-CLAMP END	A182-F316L	2
4	BALL	A182-F316L	1
5	SEAT	TFM1600 CAVITY-FILLED TFM1600	2
6	BODY SEAL	TFM1600	2
7	STEM	A479-316L	1
8	STEM THRUST WASHER	TFM1600	1
9	STEM THRUST WASHER	VIRGIN PEEK	1
10	STEM LOCATION RING	316 STAINLESS STEEL	1
11	STEM SEAL	TFM1600	3
12	GLAND FOLLOWER	304 STAINLESS STEEL	1
13	STOP PLATE	304 STAINLESS STEEL	1
14	BELLEVILLE WASHER	301 STAINLESS STEEL	2
15	JAM NUT	304 STAINLESS STEEL	1
16	LOCK TAB	304 STAINLESS STEEL	1
17	WRENCH	304 STAINLESS STEEL	1
18	WRENCH BLOCK	304 STAINLESS STEEL	1
19	HANDLE BOLT	304 STAINLESS STEEL	1
20	STOP PIN	304 STAINLESS STEEL	2
21	BODY BOLT	304 STAINLESS STEEL	16

DRAWN BY C.L.
 CHECKED BY C.L.
 APPROVED BY J.S.
(FOR REF. ONLY IF NOT APPROVED)

DATE 06/21/2017
 DATE 03/17/2021
 DATE 03/17/2021

PROJECTION THIRD ANGLE



DESCRIPTION:
 2-1/2" - 4" SB7F 3-PIECE CLEANFLOW HIGH PURITY FORGED BALL VALVE

UNITS: INCH (MILLIMETERS) DATE: 03/17/2021 REV: C