

MARSIC300

Ship Emission Measuring Device

Operation, Maintenance, Troubleshooting

SICK
Sensor Intelligence.



Described product

MARSIC300

Manufacturer

SICK AG
Erwin-Sick-Str. 1
79183 Waldkirch
Germany

Legal information

This work is protected by copyright. Any rights derived from the copyright shall be reserved for SICK AG. Reproduction of this document or parts of this document is only permissible within the limits of the legal determination of Copyright Law. Any modification, abridgment or translation of this document is prohibited without the express written permission of SICK AG.

The trademarks stated in this document are the property of their respective owner.

© SICK AG. All rights reserved.

Original document

This document is an original document of SICK AG.



Contents

1	About this document.....	7
1.1	Function of this document.....	7
1.2	Scope of application.....	7
1.3	Target group.....	7
1.4	Further information.....	8
1.5	Symbols and document conventions.....	8
1.5.1	Warning symbols.....	8
1.5.2	Warning levels / Signal words.....	8
1.5.3	Information symbols.....	9
2	Safety information.....	10
2.1	Principal safety information.....	10
2.2	Warning information on device.....	11
2.3	Intended use.....	11
2.3.1	Installation location.....	12
3	Product description.....	13
3.1	Product identification.....	13
3.2	Gas supply terminology.....	13
3.3	Layout and function.....	13
3.3.1	Gas sampling system.....	15
3.3.2	Sample gas line, heated.....	16
3.3.3	Tube bundle cable.....	16
3.3.4	Analyzer.....	17
3.3.5	Instrument air conditioning (option).....	17
3.4	Sampling point switchover.....	18
3.5	Remote maintenance (optional).....	18
3.6	Extended interfaces (optional).....	18
4	Commissioning.....	19
4.1	Before switching on.....	19
4.2	Switching on.....	19
4.3	Recognizing the safe operating state.....	19
5	Operation.....	20
5.1	Operating and display elements	20
5.1.1	Function buttons.....	20
5.2	Measuring screen.....	21
5.3	Status and classifications.....	22
5.4	Display lighting.....	22
5.5	Buffer time of internal clock.....	22
6	Adjusting with internal references / span gas.....	23
6.1	Span gas requirements.....	23
6.2	Performing a zero point adjustment.....	23

6.3	Performing a reference point adjustment.....	24
6.3.1	With internal filters.....	24
6.3.2	With span gas.....	25
6.4	Settings.....	27
6.4.1	Span gas concentrations.....	27
6.4.2	Factors.....	27
7	Menus.....	29
7.1	Password.....	29
7.2	Main menu.....	29
7.3	Menu tree.....	29
7.4	Maintenance functions.....	31
7.4.1	Maintenance signals on/off.....	31
7.4.2	Restart.....	31
7.4.3	Replacing the analyzer.....	31
7.4.4	Replacing the electronics.....	32
7.4.5	Loading factory settings.....	33
7.4.6	Save parameters on SD card.....	33
7.4.7	System maintenance.....	34
7.4.8	Confirm messages.....	35
7.5	Adjustment.....	35
7.5.1	Span gas.....	35
7.5.2	Zero point.....	36
7.5.3	Internal adjustment.....	37
7.5.4	Results.....	38
7.5.5	Settings.....	38
	7.5.5.1 Span gas concentrations.....	38
	7.5.5.2 Factors.....	39
7.6	Diagnosis.....	39
7.6.1	System info.....	39
7.6.2	Error messages.....	40
7.6.3	Device state data.....	40
	7.6.3.1 Operating hours counter.....	41
7.7	Configuring.....	42
7.7.1	Sprache / Language.....	42
7.7.2	Date and time.....	42
7.7.3	Display.....	43
	7.7.3.1 Measured values.....	43
	7.7.3.2 Scaling 1/2.....	43
	7.7.3.3 Time axis.....	44
7.7.4	I/O configuration.....	44
7.7.5	Sampling point switchover.....	45
	7.7.5.1 Activate/deactivate sampling points.....	45
	7.7.5.2 Cycle type.....	46
	7.7.5.3 Times for sampling points.....	46
	7.7.5.4 Sampling point sequence.....	47

7.7.6	Sampling point name.....	47
8	Maintenance.....	49
8.1	Important Information.....	49
8.1.1	Information on span gases.....	50
8.1.2	Tube screw fittings.....	50
8.2	Maintenance plan.....	51
8.3	Check system.....	52
8.4	Instrument air conditioning maintenance.....	53
8.5	Replacing the filter pads.....	54
8.6	Gas sampling system maintenance.....	54
8.7	Replacing the drying agent.....	59
8.8	Setting the pressure reducer module.....	59
8.9	Cell inlet filter maintenance.....	60
8.10	Replacing the cell filter non-return valve	62
8.11	Replace IR source.....	63
8.12	Performing a leak tightness check.....	66
8.13	Performing an H ₂ O check.....	67
9	Troubleshooting.....	68
9.1	Important Information.....	68
9.1.1	Information on span gases.....	69
9.1.2	Tube screw fittings.....	69
9.2	Measured values erroneous.....	70
9.3	Replace gas sampling system.....	70
9.4	Replacing the sample gas line.....	71
9.4.1	Swapping the temperature sensor Pt100 (heated sample gas line).....	73
9.5	Replacing the housing fan.....	73
9.6	Replacing the O ₂ sensor.....	74
9.7	Replacing the span gas valve.....	75
9.8	Replacing the needle valve.....	77
9.8.1	MARSIC300 with on sampling point.....	77
9.8.2	MARSIC300 with two sampling points.....	77
9.9	Replacing the cell.....	78
9.10	Replacing the pressure reducer unit.....	81
9.10.1	Setting the pressure reducer module.....	82
9.11	Replacing the pressure control module.....	83
9.12	Replacing the valve block.....	85
9.12.1	Connecting the valve block.....	86
9.13	Replacing the display.....	87
9.14	Replacing the electronics unit.....	88
9.15	Replace Analyzer module.....	93
10	Decommissioning.....	98
10.1	Switch-off states.....	98

10.2	Protective measures for long-term storage.....	98
10.3	Shipping for repair.....	99
10.4	Transport.....	99
10.5	Disposal.....	99
11	Technical data.....	101
11.1	Dimensional drawings.....	101
11.2	Design.....	102
11.3	Measuring parameters.....	102
11.4	Ambient conditions.....	103
11.5	Sample gas conditions.....	103
11.6	Heated sample gas lines.....	104
11.7	Tube bundle cable.....	104
11.8	Interfaces and protocols.....	105
11.9	Power supply.....	105
11.10	Connections in analyzer.....	106
11.11	Circuit breakers.....	109
11.12	Supply gases.....	110
11.13	Tube connections.....	110
11.14	Torques.....	110
12	Annex.....	112
12.1	Error messages and possible causes.....	112
12.2	Consumable parts, wearing parts and spare parts.....	119
12.3	Compliances.....	123
12.4	Licences.....	124

1 About this document

1.1 Function of this document

These Operating Instructions describe:

- System components
- Start-up
- Operation
- Maintenance work required for reliable operation
- Troubleshooting

1.2 Scope of application

These Operating Instructions are only applicable for the measuring device described in the product identification.

They are not applicable for other SICK measuring devices.

The standards referred to in these Operating Instructions are to be observed in the respective valid version.

1.3 Target group

This document is addressed to technicians (persons with technical understanding) operating and maintaining the measuring system.

Responsibility of the operator

- Use the device only as described in these Operating Instructions; the manufacturer assumes no responsibility for any other use.
- Perform the specified maintenance work.
- Do not remove, add or change any components in or on the device unless such changes are officially allowed and specified by the manufacturer.
 - Otherwise the manufacturer's warranty becomes void.
 - Otherwise the device could become dangerous.
- Observe special local conditions.
 - Follow all local laws, regulations and company-internal operating directives applicable at the respective installation location.
- Retain documents. These Operating Instructions:
 - Must be kept available for reference.
 - Must be conveyed to new owners.

Requirements for the maintenance personnel

- The technician must be familiar with the exhaust gas technology of the operator's plant (overpressure, toxic and hot sample gases) and be able to avoid hazards when working on gas ducts.
- The technician must be familiar with handling compressed gas cylinders (test gases).
- The technician must be able to avoid hazards caused by noxious test gases.
- The technician must be familiar with gas lines (PTFE lines) and their screw fittings (be able to ensure gas-tight connections).
- Only allow an authorized electrician to work on the electrical system or electrical subassemblies.







1.4 Further information

- Technical Information MARSIC300
- Gas Sampling System SFU Operating Instructions
- Sample Gas Line Operating Instructions
- System documentation
- Short instructions for MARSIC300
- Safety information (for SICK analyzer devices)
- Optional: MPR (Meeting Point Router) Operating Instructions
- Optional: Instrument Air Conditioning Operating Instructions
- Optional: Pressure Test Tool Operating Instructions
- Optional: Operating Instructions Profibus/Profinet converter
- Optional: Operating Instructions HOTSAMPLER (sampling point extension)

1.5 Symbols and document conventions

1.5.1 Warning symbols

Table 1: Warning symbols

Symbol	Significance
	Hazard (general)
	Hazard by voltage
	Risk of explosion
	Hazard by acidic substances
	Hazards by noxious substances
	Hazard by high temperature
	Hazard for the environment/nature/organic life

1.5.2 Warning levels / Signal words

DANGER

Risk or hazardous situation which will result in severe personal injury or death.

WARNING

Risk or hazardous situation which could result in severe personal injury or death.

CAUTION

Hazard or unsafe practice which could result in less severe or minor injuries.

Notice



Hazard which could result in property damage.

Note

Hints

1.5.3 Information symbols

Table 2: Information symbols

Symbol	Significance
	Important technical information for this product
	Important information on electric or electronic functions

2 Safety information

2.1 Principal safety information

- ▶ Read and observe these Operating Instructions.
- ▶ Observe all safety instructions.
- ▶ If anything is not clear: Please contact SICK Customer Service.

- Basis of this Manual is the delivery of the device according to the preceding project planning (e.g., based on the SICK application questionnaire) and the relevant delivery state of the device (see delivered System Documentation).
 - ▶ If you are not sure whether the device corresponds to the state defined during project planning or to the delivered system documentation: Please contact SICK Customer Service.

- ▶ Use the device only as described in “Intended use”.
The manufacturer assumes no responsibility for any other use.
- ▶ Perform the prescribed maintenance work.
- ▶ Do not carry out any work or repairs on the device that are not described in this Manual.
Do not remove, add or change any components in or on the device unless such changes are officially allowed and specified by the manufacturer.
If you do not observe this:
 - The manufacturer's warranty becomes void.
 - The device could become dangerous.
 - The approval for use in potentially explosive atmospheres becomes void.

Electrical compliance



WARNING

Endangerment of electrical safety during installation and maintenance work when the power supply is not switched off

An electrical accident can occur during installation and maintenance work when the power supply to the device and/or lines is not switched off using a power isolating switch/circuit breaker.

- ▶ Before starting the work, ensure the power supply can be switched off using a power isolating switch/circuit breaker in accordance with DIN EN 61010.
- ▶ Make sure the power isolating switch is easily accessible.
- ▶ An additional separation device is mandatory when the power isolating switch cannot be accessed or only with difficulty after installation of the device connection.
- ▶ The power supply may only be switched on again after work completion or for test purposes by the persons carrying out the work under consideration of the valid safety regulations.



WARNING

Endangerment of electrical safety through power cables with incorrect rating

Electrical accidents can occur when the specifications for replacement of a removable power cable have not been adequately observed.

- ▶ Always observe the exact specifications in the Operating Instructions (Technical Data Chapter) when replacing a removable power line.
-

Device grounding



NOTICE

Device damage through incorrect or missing grounding

During installation and maintenance work, it must be ensured that the protective grounding to the devices and/or lines involved is effective in accordance with EN 61010-1.

Responsibility for system safety



NOTICE

Responsibility for system safety

The person setting the system up is responsible for the safety of the system in which the device is integrated.

Dangerous substances



WARNING

Mortal/health danger as a result of gas path leakage.



When the device measures noxious gases: A leak in the gas path can be an acute danger for persons.

- ▶ Take suitable safety measures. For example:
 - Attach warning signs to the device.
 - Attach warning signs in the operating area.
 - Safety-oriented instruction of persons that could be in this area.

2.2 Warning information on device

The following safety symbols are on the device:

Table 3: Warning symbols

Symbol	Significance
	Warning for general hazard
	Warning for hazard by electric voltage, possibly also by residual electric voltage
	Warning for hazard through hot surfaces

If you need to work on a subassembly marked with such a symbol:

- ▶ Read the relevant Section in these Operating Instructions
- ▶ Observe all the safety information in the relevant Section

2.3 Intended use

MARSIC serves emission monitoring on maritime combustion engines.

2.3.1 Installation location

- Observe the regulations and Operating Instructions valid on board.
- Operate MARSIC only below deck in well ventilated rooms.



WARNING

Risk of explosion in potentially explosive atmospheres

- ▶ Do not operate the device and its subassemblies in potentially explosive atmospheres.
-

3 Product description

3.1 Product identification

Table 4: Product identification

Product name	MARSIC300
Manufacturer	SICK AG Erwin-Sick-Str. 1 · 79183 Waldkirch · Germany
Type plate	Type plates are located outside on the right of the housing and inside the housing

3.2 Gas supply terminology

Definition of utility gases:

- Zero gas: Gas to adjust the zero point. Instrument air or nitrogen (N₂)
- Span gas: Gas to adjust the upper measuring range value
- Test gas: Generic term for zero and span gas
- Instrument air: Clean compressed air

Gas quality: [see "Supply gases", page 110.](#)

3.3 Layout and function

System overview

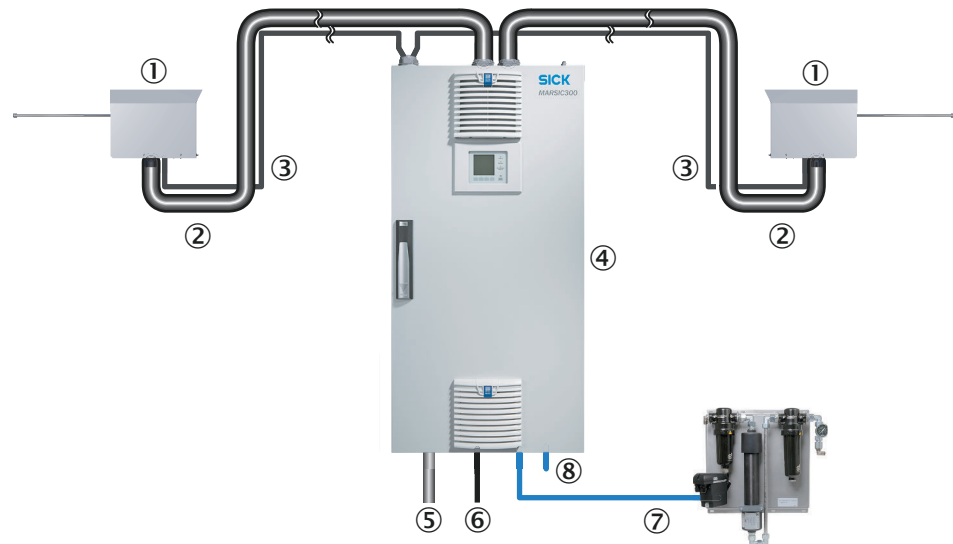

Figure 1: System overview (schematic)

①	Gas sampling system (Option: 2 gas sampling systems)	see "Gas sampling system", page 15
②	Heated sample gas line (Option: 2 sample gas lines)	see "Sample gas line, heated", page 16
③	Tube bundle cable (with 2 sampling points: 2 tube bundle cables) with: <ul style="list-style-type: none"> • Instrument air line • Power supply 	see "Tube bundle cable", page 16
④	Analyzer cabinet	see "Analyzer", page 17

⑤	Power supply	see "Power supply", page 105
⑥	Interfaces	1 x Ethernet: Connections see "Connections in analyzer", page 106
⑦	Instrument air inlet Option: Instrument air conditioning	Observe quality of operator's instrument air: see "Supply gases", page 110 A separate instrument air supply can also be connected as zero gas (IR components) or span gas (O ₂ sensor).
⑧	Sample gas outlet	



CAUTION

Risk of contamination of analyzer

The gas sampling system and analyzer are flushed with instrument air when the system is not in measuring operation.

The analyzer can be contaminated when instrument air is switched off.

- ▶ Take the gas sampling system out of the exhaust duct when instrument air is not available for a longer period of time (see "Replace gas sampling system", page 70)

Measuring principle

- IR components: Single-beam infrared photometer with dual frequency and gas filter correlation method
- Oxygen: Zirconium dioxide sensor

Measuring components

Measured values are output as volume concentration (ppm/% by volume) relative to dry flue gas.

See the system documentation provided for the configuration of your system.

Function

The system operates independently.

Operation is performed via the control unit in the analyzer door.

Operating states are signaled by status signals and shown on the display.

- Extraction of flue gas at the sampling point (option: 2 sampling points per device or up to 8 sampling points with external sampling point switchover HOTSAMPLER) with a heated gas sampling system
- Sample gas feed to the analyzer in a heated sample gas line
- Heating temperature of all parts with sample gas contact: 200 °C
- Pump: Ejector pump in cell (driven with instrument air)
- The analyzer uses status indicators to signal the current operating state: see "Status and classifications", page 22
- The analyzer switches to operating state "System Stop" automatically when a malfunction occurs
"System Stop" corresponds to classification "Failure": see "Status and classifications", page 22
 - In this state, the sample gas line and sample gas path in the analyzer are flushed automatically with instrument air
 - Measured values are updated further

Check (validation) and adjustment

- Adjustment with zero gas
 - Automatic (default setting: daily, duration approx. 15 minutes)
 - Manual: [see "Performing a zero point adjustment", page 23](#)
- Adjustment with span gases:
 - Manual: [see "Adjustment", page 35](#)
- Adjustment without span gases (internal adjustment):
 - Automatic (default setting: monthly, duration approx. 10 minutes)
 - Manual: [see "With internal filters", page 24](#)
- Sampling point switchover: [see "Sampling point switchover", page 18](#)
- Backflushing the gas sampling system
 - Automatic (configuration with SOPAS ET, duration, e.g., 2 minutes every 4 hours)
 - Manual: [see "System maintenance", page 34](#)

Operation via control unit**Operation via external PC (optional)**

Operator menus and measured value displays are also available for easy use on an external PC via the Ethernet connection (with the SOPAS ET engineering tool).

You can download SOPAS ET free of charge from the SICK homepage.

Further information, see “MARSIC300 Technical Information”.

3.3.1 Gas sampling system

Figure 2: Gas sampling system (example with heated probe tube)

- The gas sampling system extracts the sample gas from the exhaust duct
- The probe tube is:
 - Not heated
 - Or heated
- The gas sampling system is thermostatic-controlled
- The analyzer regulates the heaters:

Only the heated sample gas line leading to the HOTSAMPLER is regulated by the MARSIC300 when the heated sample gas extension HOTSAMPLER is used. The HOTSAMPLER regulates all sample gas sampling as well as sample gas lines connected to the HOTSAMPLER.
- When no voltage is applied, the “heated sample gas line” and the analyzer are flushed with instrument air

**NOTE**

- ▶ For further information on the gas sampling system: See the provided “Gas Sampling System SFU Operating Instructions”

3.3.2 Sample gas line, heated

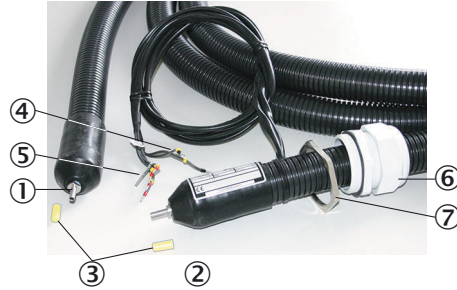

Figure 3: Sample gas line, heated

- ① Connection side without electric connection on gas sampling system
- ② Connection side with electric connections on analyzer
- ③ Protective cap
- ④ 2 x Pt100 connections (1 as reserve)
- ⑤ Power supply
- ⑥ Cable gland
- ⑦ Counter nut

- The heated sample gas line leads the flue gas from the gas sampling system to the analyzer
- The sample gas line is thermostatic-controlled to prevent condensation of the flue gas
 - The analyzer regulates the heating (see "Device state data", page 40)

3.3.3 Tube bundle cable

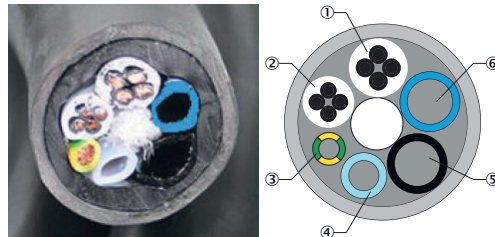

Figure 4: Tube bundle cable

- ① Power supply
- ② Pt100 lines
- ③ Grounding conductor
- ④ PTFE tube DN4/6
- ⑤ PA tube, white, DN6/8; Imprint "1"
- ⑥ PA tube black DN6/8; Imprint "2"



NOTE

Connections on analyzer and gas sampling probe must match.

The tube bundle cable comprises:

- Gas line for instrument air feed of the gas sampling system
- Power supply of the gas sampling system
- Control lines

3.3.4 Analyzer

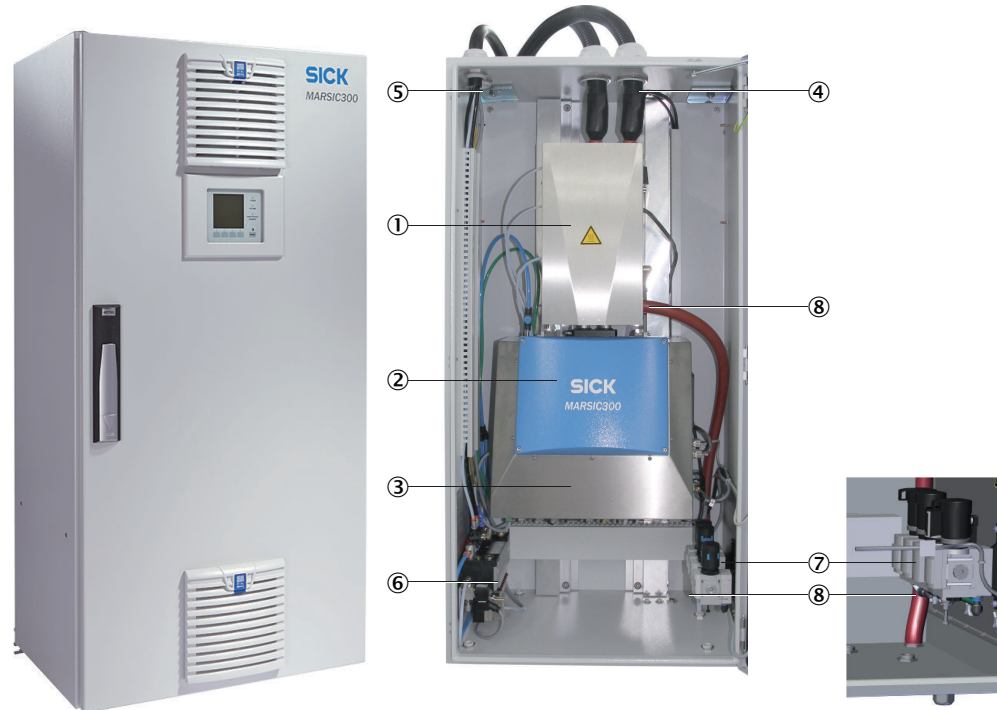

Figure 5: Exterior view and analyzer module

Analyzer module

- ① Measuring cell (cell) with:
 - Ejector pump
 - Inlet filter
- ② Photometer
- ③ Electronics

Analyzer - subassemblies

- ④ Sample gas inlet (heated sample gas line)
(With 2 sampling points: Sample gas inlet "1" on the right side)
- ⑤ Tube bundle cable
(With 2 sampling points: 2 tube bundle cables)
- ⑥ Valve block
- ⑦ Pressure reducer unit
Important: Observe quality of operator's instrument air: [see "Supply gases", page 110](#)
- ⑧ Sample gas outlet

3.3.5 Instrument air conditioning (option)



NOTICE

Only feed conditioned instrument air to the analyzer. The instrument air quality is specified in Annex [chapter 11.12](#). Operation with air not satisfying these specifications voids the warranty and does not ensure proper functioning of the device.

Instrument air conditioning serves to condition the compressed air provided by the operator.

- ▶ Refer to the Instrument Air Conditioning Operating Instructions delivered with the system for further information

3.4 Sampling point switchover

Up to 2 sampling points can be activated using the internal sampling point switchover (optional) and up to 8 with the external sampling point switchover HOTSAMPLER (optional).



NOTE

For measurement in accordance with MEPC.259(68), “Scheme B”, all sampling points are to be measured with a frequency of 0.0035 Hz, i.e. each sampling point must be measured at least once within 4:45 minutes. The MARSIC300 measures maximum 2 sampling points within 4:45 minutes.

Programmable for each sampling point:

- Sampling point name (freely selectable)
- Hold time (wait time before measured value output after switchover)
- Active (valid measurement after hold time)

For configuring: See “MARSIC300 Technical Information”.

When several sampling points are active, the measured values held for inactive sampling points are also output in addition to the measured value of the active sampling point.

Holding the measured value: The measured value for an active sampling point is the current measured value for this sampling point (after the hold time).

When other sampling points are active, the measured value for this sampling point remains constant as the last measured value measured by this sampling point (sample-and-hold amplifier function).

3.5 Remote maintenance (optional)

The SICK Meeting Point Router (MPR) is available for remote diagnostics via the internet.

The MPR links a plant-side machine network with the SICK remote architecture.

A firewall which decouples the machine network from the internet or the operating company network is integrated in the MPR.



NOTE

An internet connection must be available.

Further information, see optional “MPR Operating Instructions”.

3.6 Extended interfaces (optional)

The MODBUS TCP protocol is used as standard for MARSIC300 communication with customer peripherals. MODBUS registers for measured values and functions, see MARSIC300 Technical Information.

SICK also offers various optional converter modules that can be installed by the customer for communication with the MARSIC300 via MODBUS TCP. Available options

- Profibus / Profinet
- Analog outputs
- Digital inputs/outputs

4 Commissioning

4.1 Before switching on



NOTICE

For installation and initial commissioning, see “MARSIC300 Technical Information”

Before switching on ...

- ▶ Check the system: [see "Check system", page 52](#)
- ▶ Instrument air must be connected and open
 - If the instrument air supply has changed: Check the instrument air quality. Specified quality: [see "Supply gases", page 110](#)

4.2 Switching on

Switching on

1. Switch on the external power disconnection unit:
 - The **green** “Power” LED on the control panel goes on: Energy supply is available.
 - The yellow and red LEDs go on sporadically.
 - “**Booting**” appears several times on the screen.
 - The Measuring screen opens.
 - The system heats up:
 - ▶ **Only the green LED is on.**
 - ▶ Display: **Init/Heating up.**
 - ▶ A downwards counter displays the maximum duration of the process.
 - Display: **Conditioning.**
 - Only the **green** LED is on and **Measuring** is shown in the status line. The system is ready for operation.
 - ▶ If a measured values blinks: The measured value is outside the calibration range.
 - ▶ When the yellow or red LED is on: Press the Diag button and clear the error: Error list [see "Error messages and possible causes", page 112.](#)
 - If the measuring system has not been in operation for an extended period of time or work on the sample gas path has been performed:
 - ▶ Perform a leak tightness check: [see "Performing a leak tightness check", page 66.](#)
- The system is in operation.

4.3 Recognizing the safe operating state

The system is in proper operation when:

- A system check has been carried out according to the Maintenance plan before commissioning and in running operation ([see "Check system", page 52](#))
- A leak tightness check has been carried out according to the Maintenance plan before commissioning and in running operation ([see "Performing a leak tightness check", page 66](#))
- Only the **green** LED is on and the status bar shows **Measuring**
 - ▶ When the yellow or red LED is on: Press the Diag button and clear the error: Error list, [see "Error messages and possible causes", page 112](#)

5 Operation

5.1 Operating and display elements

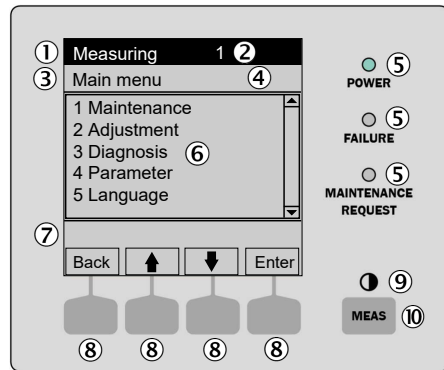

Figure 6: Display - overview

- ① Status bar
- ② With sampling point switchover: Active sampling point
- ③ Current menu
- ④ Menu number
- ⑤ LEDs
- ⑥ Menu contents
- ⑦ Current menu branch in short form
- ⑧ Function button (function is displayed)
ENTER
MENU, etc.
- ⑨ Contrast: Press the **MEAS** button for several seconds
- ⑩ **MEAS** button: Measuring screen

5.1.1 Function buttons

Table 5: Function button - MEAS

Button	Function
MEAS	Return to the Measuring screen from any menu (see "Measuring screen", page 21)
	<ul style="list-style-type: none"> • If you have made changes in a menu: Press the <Save> button before leaving the menu. Otherwise the changes are lost • If the device is switched to "Maintenance": Pressing the MEAS button does not affect the "Maintenance" state
	In the Measuring screen: Toggle between list, bar graph and line format.
●	To set the contrast: Press the MEAS button for longer than 2 seconds.

The current function of the function buttons is shown on the display.

Table 6: Function buttons

Display	Function
Back	Return to the higher level menu. Press <Save> to store any changes made. Otherwise the changes are lost.
Diag	Diag is shown only when there is a message pending. To display the message: Press this button. Further information on Diagnosis : see "Error messages", page 40. List of error messages: see "Error messages and possible causes", page 112.
Enter	Call up/start selected menu function
Menu	Call up the menu overview: see "Menu tree", page 29. If the <Menu> button is not shown: Press MEAS first.
Save	Save input/exit
Set	Start setting
Select	Select function/character
Start	Start procedure
↑	In a selection list: Move cursor upwards
	During input: Next character

Display	Function
↓	Move cursor downwards
←	Move cursor to the left
→	Move cursor to the right

5.2 Measuring screen

“List” (default)

Measuring	
SO2	xx.x ppm
CO2	xx.x % by vol.
SO2/CO2	xxxx
O2	xx.x % by vol.
Flow	xx l/h
Pressure	xxxx hPa
<div style="display: flex; justify-content: space-between; align-items: center;"> ↑ ↓ Menu </div>	

Bar graph diagram

Measuring	
Comp.1	701
<div style="display: flex; justify-content: space-between;"> <div style="width: 70%; height: 15px; background-color: black;"></div> </div>	
0 ppm 1000	
Comp.2	241
<div style="display: flex; justify-content: space-between;"> <div style="width: 30%; height: 15px; background-color: black;"></div> </div>	
0 ppm 750	
<div style="display: flex; justify-content: space-between; align-items: center;"> ↑ ↓ Menu </div>	

Line diagram

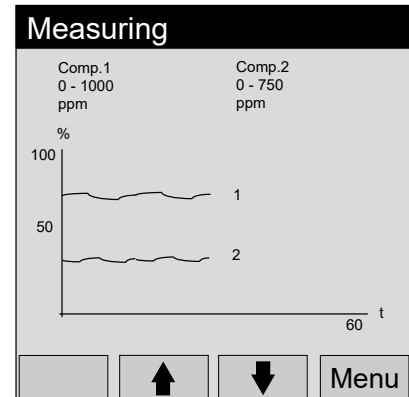

Measured value “Pressure” in menu “Measuring screen” is rounded up to 10 hPa.

- Toggling between Measuring screens: **MEAS** button
- Main menu: **MENU** button

Measuring screen “List”

Displays measured values in tabular format.

Measuring screen “List” is displayed:

- Automatically after system start
- By pressing the **MEAS** button

Update interval: 1 second (default setting)

Measuring screen “Bar graph diagram”

Displays 2 measured values in bar graph format.

Update interval: 1 second

- ▶ Display contents configuration: [see "Display", page 43](#)

Measuring screen “Line diagram”

Displays 2 measured values in time diagram.

The y-axis is always scaled to 0 - 100% of the display range.

(The respective display range is shown underneath the components)

Line 1 = left component. Line 2 = right component.

Update interval:

Table 7: Updating the intervals

Time axis [min]	Update interval [sec.]
6	4
15	10

Time axis [min]	Update interval [sec.]
30	20
60	40

- Display ranges configuration: [see "Display", page 43](#)

5.3 Status and classifications

Device status (operating state)

The respective operating state (e.g.: measuring, heating) is shown in the top line of the display.

Classification, LEDs

The classification (error status) is indicated by LEDs on the control panel and recorded in the logbook (SOPAS ET).

Table 8: LEDs - classification

Classification	LED	Significance	Measuring screen
Maintenance Wartung Function control	Green	The analyzer is switched to Maintenance per menu or program. The status bar shows: Status: Maintenance.	Current
Uncertain Unsicher	Green	Measured value outside the calibration range.	Current
Maintenance request Wartungsbedarf	Green, yellow	Sporadic errors (e.g. deviation too high during control cycle) make a check for the cause necessary. View cause: Press the Diag button.	Current
Failure Ausfall	Green, red	Device failure, "System Stop" View cause: Press the Diag button.	Current
Extended Erweitert	Green	Extended message	Current

Table with malfunction messages and possible causes: [see "Error messages and possible causes", page 112](#)

5.4 Display lighting

The display lighting can switch off automatically

- If the display is dark: Press the left or right function button.
- If this does not work: Check that the device is switched on (POWER on) and/or the power voltage is present.

5.5 Buffer time of internal clock

If process flow sequences that are to be started by the internal clock (e.g., automatic adjustments) are defined:

- If the device has been out of operation longer than 3 ... 5 days: Reset the internal clock after commissioning, [see "Date and time", page 42.](#)

6 Adjusting with internal references / span gas

Information on adjustment

- “Zero gas” and “Internal reference” adjustments run cyclically (preset) but can also be started manually
- Span gas adjustment can only be performed manually
- The following menus describe “manual” adjustments

Validation

Checks the measured value of a measuring component using span gas without correcting the measured value.

Adjustment

Checks the measured value of a measuring component using span gas and corrects the current measured value to the configured (see ["Span gas concentrations"](#), page 27) span gas concentration.

Internal adjustment / Internal validation

“Internal adjustment” or “internal validation” checks are performed using an internal standard instead of span gas.

O₂ is adjusted to the oxygen content of the instrument air (standard 20.95 % by volume, configuration see ["Measuring parameters"](#), page 102).

6.1 Span gas requirements



NOTICE

Observe the span gas conditions: see ["Supply gases"](#), page 110

The concentration of the span gas used should correspond to 80 % ... 100% of the measuring range value. Span gas accuracy should be at least $\pm 2\%$. Further span gas requirements: see ["Sample gas conditions"](#), page 103.

Check that the required quality and amount of instrument air is available before adjustment.

6.2 Performing a zero point adjustment

Menu: Adjustment/Zero point

This menu serves to validate or adjust the zero points of the measured values when feeding instrument air.

When starting a program:

- The maintenance signal on the analyzer switches to “on” and the yellow LED on the display goes on
- The Measuring screen appears with the message: “Program started”
- The program name appears in the status bar and, for self-terminating programs, a counter with the maximum program duration
- The program terminates with the message (temporary): “Program terminated”
- Then the status bar shows “Measuring” again and the device is in regular measuring operation again

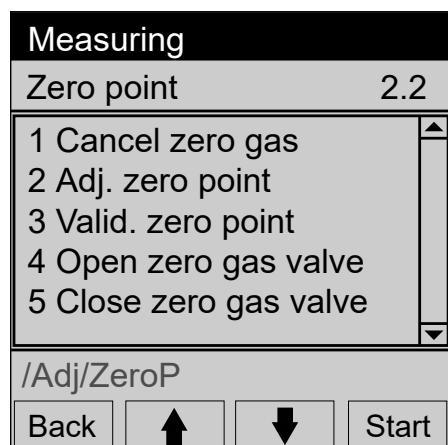

Figure 7: Zero point menu

- 1 **Cancel zero gas**
Cancels a check started in this menu.
The system returns to measuring operation.
- 2 **Adj. zero point**
Starts zero point adjustment
Instrument air is fed automatically to the system.
An automatic zero point adjustment of all components then follows.
 - Switch the maintenance signal on: [see "Maintenance signals on/off", page 31](#)
 - Start adjustment with "Start".
 - The Measuring screen opens (with a downwards counter to the end of the adjustment).
 - The system switches back to operating state "Measuring" automatically when the adjustment has completed (when "Maintenance" was set manually beforehand: Back in "Maintenance").
 - Adjustment result: [see "Results", page 38](#).
 - The components are set to "Zero" when the adjustment was successful.
 - If the deviation is higher than a specified limit value, the system switches to classification "Maintenance request" and the zero point is however corrected.
 - Switch the maintenance signal off again: [see "Maintenance signals on/off", page 31](#)
- 3 **Valid. zero point**
Start zero point validation
Procedure as above but the measured values are only displayed and not corrected.
- 4 **Open zero gas valve**
Open the zero gas valve: The display (Measuring screen) shows the measured value of the zero gas.
- 5 **Close zero gas valve**
Close the zero gas valve again.

6.3 Performing a reference point adjustment

6.3.1 With internal filters

Menu: Adjustment/Internal adj.

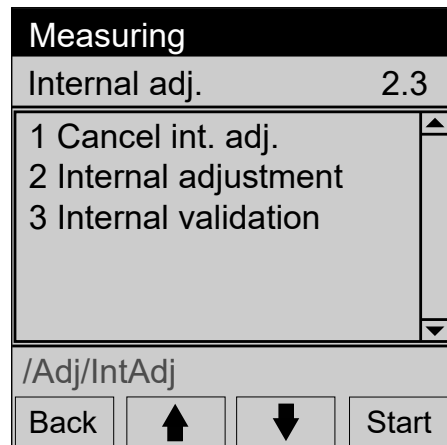

Figure 8: Internal adjustment menu

- 1 **Cancel int. adj.**
Cancels a check started in this menu.
The system returns to measuring operation.
- 2 **Internal adjustment**
Start an internal adjustment.
 - Switch the maintenance signal on: [see "Maintenance signals on/off", page 31](#)
 - Start adjustment with “Start”
 - The Measuring screen appears (with a downwards counter to the end of the adjustment).
 - The system switches back to operating state “Measuring” automatically when the adjustment has completed (when “Maintenance” was set manually beforehand: The system switches back to “Maintenance”)
 - Adjustment result: [see "Results", page 38](#).
 - If the deviation is higher than a specified limit value, the system switches to classification “Maintenance request”. The drift value is saved but the measured value is not corrected
 - Switch the maintenance signal off again: [see "Maintenance signals on/off", page 31](#)
- 3 **Internal validation**
Start an internal validation.
Procedure as above but the measured values are not corrected.
Adjustment result: [see "Results", page 38](#).

6.3.2 With span gas

Menu: **Adjustment/Span gas**

This menu serves to switch span gas feed on and off and, as necessary, to adjust the respective measuring component.



NOTICE

Observe the span gas conditions: [see "Supply gases", page 110](#)

When starting a program:

- The maintenance signal on the analyzer switches to “on” and the yellow LED on the display goes on
- The Measuring screen appears with the message: “Program started”
- The program name appears in the status bar and, for self-terminating programs, a counter with the maximum program duration

- The program terminates with the message (temporary): “Program terminated”
- Then the status bar shows “Measuring” again and the device is in regular measuring operation again

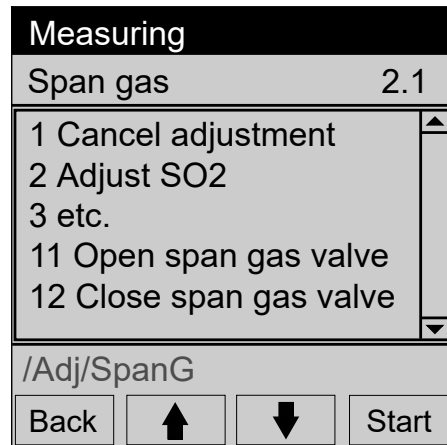

Figure 9: Span gas menu

1 Cancel adjustment

Cancel a running adjustment started in this menu.
The system returns to measuring operation.

2 Adjust SO₂ (example)

- Compare the set span gas concentration with the certificate of the span gas cylinder and, when necessary, change this in the device: [see "Span gas concentrations", page 27](#)
- Switch the maintenance signal on when necessary: [see "Maintenance signals on/off", page 31](#)
- Connect the desired span gas to the span gas valve: [see "Connecting the valve block", page 86](#)
- Turn the span gas on and set the pressure to approx. 3.5 bar
- Start adjustment with “Start”
- The span gas flow rate is shown on the display (Measuring screen).
As long as the span gas flow rate is not correct: An appropriate message is shown
- Adjust the pressure on the cylinder pressure reducer so that the flow shown is 200 ... 400 l/h
- The Measuring screen appears (with a downwards counter to the end of the adjustment)
- The system switches back to operating state “Measuring” automatically when the adjustment has completed (when “Maintenance” was set manually beforehand: The system switches back to “Maintenance”)
- Adjustment result: [see "Results", page 38](#)
- If the deviation is higher than a specified limit value, the system switches to classification “Maintenance request” and the measured value is not corrected
- Shut off the span gas cylinder
- Switch the maintenance signal off again when necessary: [see "Maintenance signals on/off", page 31](#)

3 Adjustment of further components corresponding to measured components in the device.

See above for procedure.

10 **Adjust O₂**

O₂ is adjusted using instrument air.

The device flushes automatically with instrument air and the oxygen content of the instrument air is used for measurement.

This sets the zero and reference points.

11 **Open span gas valve**

Open the span gas valve: The display (Measuring screen) shows the measured value of the span gas.

12 **Close span gas valve**

Close the span gas valve again.

6.4 **Settings**

Menu: Adjustment/Settings

6.4.1 **Span gas concentrations**

Menu: Adjustment/Settings/Span gas

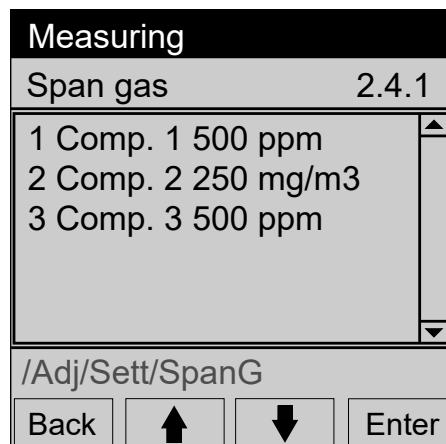

This menu serves to enter the concentrations of the span gases.

Figure 10: Span gas concentration menu

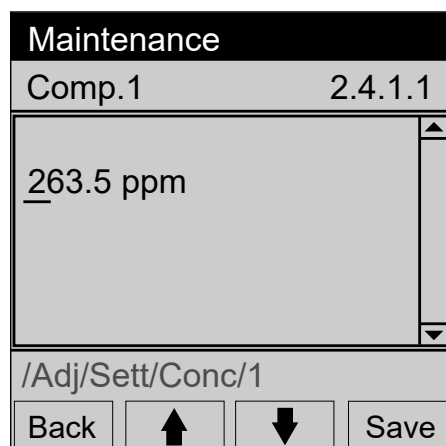

Figure 11: Concentration menu

6.4.2 **Factors**

Menu: Adjustment/Settings/Factors

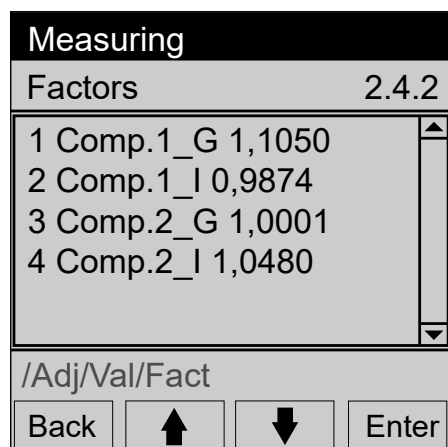

Figure 12: Main menu

This menu shows the current correction factors of the measuring components.

There are 2 correction factors per component:

- **_G**: Correction factor for span gas.
- **_I**: Correction factor for internal adjustment standard (option).

7 Menus

7.1 Password

A password prompt is displayed when configuration changes are only possible at user level “Authorized operator”.

Password for “Authorized operator”: **1234** (preset).

If you do not make any entry for several minutes (preset to 30 minutes), user level “Operator” is switched to automatically again.

To change the password: See “MARSIC300 Technical Information”.

7.2 Main menu

Main menu

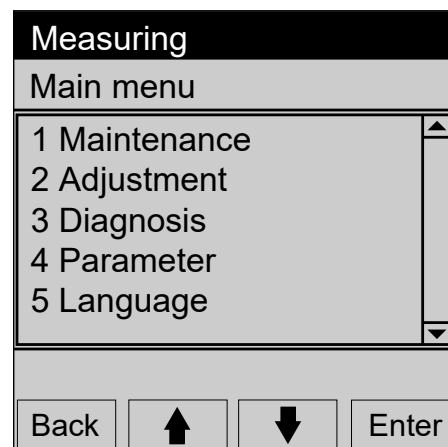

Figure 13: Main menu



NOTE

- Measuring screen: see "Measuring screen", page 21
- Use function button **MENU** in the measuring screen to go to the main menu.

7.3 Menu tree

Password: see "Password", page 29

Menu level	Explanation
Maintenance	chapter 7.4
Maintenance signal	see chapter 7.4.1
On	
Off	
Restart	chapter 7.4.2
Replacing the analyzer	chapter 7.4.3
Replacing the electronics	chapter 7.4.4
Save parameters	chapter 7.4.6
Save SD1	
Save SD2	
Load SD1	
Load SD2	
Load default set.	
System maintenance	chapter 7.4.7
Standby	

Abort Standby	
Cancel system Mainte	
Flushback sensor	
Leakage test	
Test pressure sensor	
Adjust pressure sens	
Confirm messages	chapter 7.4.8
Adjustment	chapter 7.5
Span gas	chapter 6.3.2
Cancel adjustment	Abort adjustment with span gas
Adjust "Component"	Start adjustment of a component with span gas
etc.	
Open span gas valve	Open span gas valve
Close span gas valve	Close span gas valve
Zero point	chapter 6.2
Cancel zero gas	Cancel zero point adjustment
Adjust zero	Start zero point adjustment
Check zero gas	Start zero point validation
Open zero gas valve	Open zero gas valve
Close zero gas valve	Close zero gas valve
Internal adjustment	chapter 6.3.1
Cancel int, adj.	Cancel internal adjustment
Adjust internal	Start adjustment with internal standard
Internal validation	Start validation with internal standard
Settings	chapter 6.4
Span gas	
Factors	
Diagnosis	chapter 7.6
Error messages	chapter 7.6.2
Device state data	chapter 7.6.3
Counter op. hours	
Temperatures	
Voltages	
Currents	
Chopper	
Cell	
Reference energy	
I/O config.	chapter 7.7.4
Digital outputs	
Digital inputs	
Ethernet	
System info	chapter 7.6.1
Results	chapter 7.5.4
Adj. span gas	
Adj. internal	
Parameter	chapter 7.7
Device display	chapter 7.7.3
Measured values	
Scaling 1	
Scaling 2	
Time axis	
Date/Time	chapter 7.7.2
Location	chapter 7.7.6
Sampling points	chapter 7.7.5
Active/Deactive	
Cycle type	
Times	
Order	
Language	see chapter 7.7.1
German	
English	

7.4 Maintenance functions



NOTE

- Menu representation is optimized for the description and does not always correspond exactly to the actual representation on the display.
- All numeric values in the menu described here are examples without metrological significance
Realistic values depend on the individual device

7.4.1 Maintenance signals on/off

Menu: Maintenance/Maintenance signal

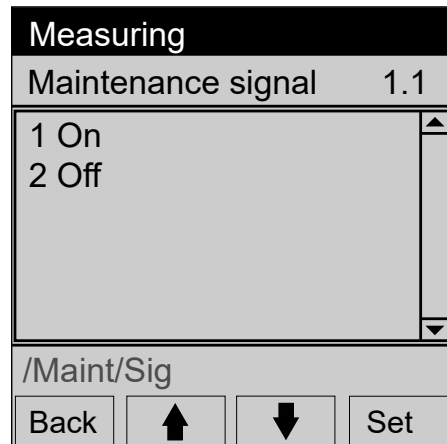

- 1 The maintenance signal is set. Then:
 - Classification "Maintenance".
 - Status bar: "Status: Maintenance".
- 2 The maintenance signal is reset.

Figure 14: Maintenance signal menu

7.4.2 Restart

Menu: Maintenance/Reset

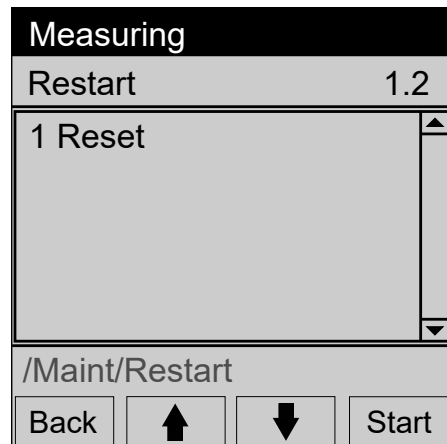

- 1 Trigger restart.
 - A hardware reset (same significance as: Main supply voltage off/on) is performed.

Figure 15: Restart menu

7.4.3 Replacing the analyzer

This function serves to load device-specific parameters after exchanging the analyzer. A data backup is required for this function (see ["Save parameters on SD card", page 33](#)).

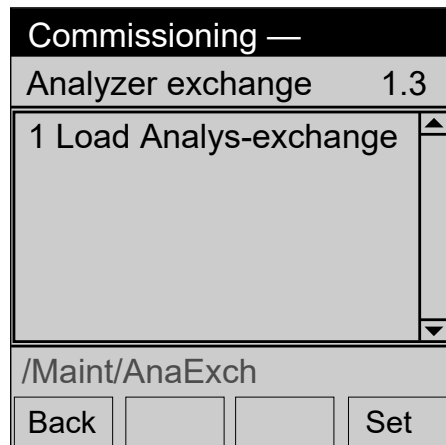

Figure 16: Measuring/Parameter backup

1. Backup data on SD card.
The SD card is located on the right side of the electronic housing (see ["Connections in analyzer", page 106](#)).
2. Exchange the analyzer ([chapter 7.4.3](#)).
3. Insert the SD card of the previous electronics in the new electronics.
4. Switch device on.
5. Select menu **Maintenance**.
6. Select menu **Analyser exchange**.
7. Select menu **load Analys-exchang**.
8. Enter password.
9. Wait until the device restarts.

7.4.4 Replacing the electronics

This function serves to load device-specific parameters after exchanging the electronics unit. A data backup is required for this function (see ["Save parameters on SD card", page 33](#)).

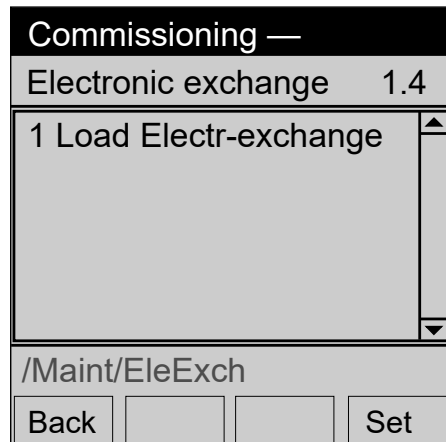

Figure 17: Measuring/Parameter backup

1. Backup data on SD card.
The SD card is located on the right side of the electronic housing (see ["Connections in analyzer", page 106](#)).
2. Exchange the electronics unit ([chapter 7.4.4](#)).
3. Insert the SD card of the previous electronics in the new electronics.
4. Switch device on.
5. Select menu **Maintenance**.

6. Select menu **Electronic exchange**.
7. Select menu **load Electr-exchang**.
8. Enter password.
9. Wait until the device restarts.

7.4.5 Loading factory settings

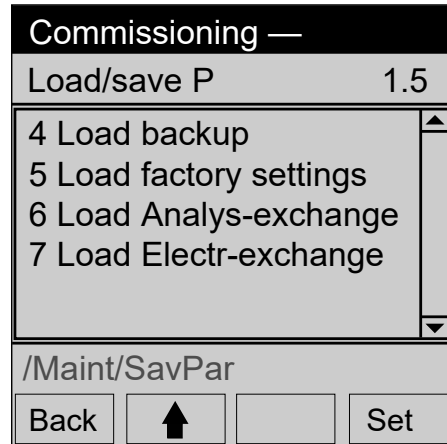

Figure 18: Commissioning/Load factory settings menu

This function serves to reset to the factory settings.



NOTICE

All individual settings / parameter settings are reset. Contact SICK Customer service when you are unsure.

7.4.6 Save parameters on SD card

Device-specific settings can be saved and reloaded. Either the factory settings or just the parameters required after exchanging the analyzer or electronics unit can be reloaded.

Menu: **Maintenance/Save Parameters**

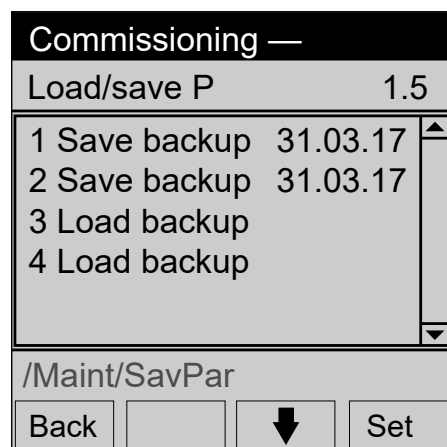

- 1 The current parameters are saved as "SD1" with the current date on the SD card.
- 2 The current parameters are saved as "SD2" with the current date on the SD card.
- 3 The parameters are loaded from SD1 storage.
- 4 The parameters are loaded from SD2 storage.
- 5 Load factory setting.

Figure 19: Measuring/Parameter backup

The SD card is located on the right side of the electronic housing (see ["Connections in analyzer"](#), page 106).

7.4.7 System maintenance

Menu: **Maintenance/Maint sys.**

This menu serves to start various maintenance procedures.

When starting a program:

- The maintenance signal on the analyzer switches to “on” and the yellow LED on the display goes on
- The Measuring screen appears with the message: “Program started”
- The program name appears in the status bar and, for self-terminating programs, a counter with the maximum program duration
- The program terminates with the message (temporary): “Program terminated”
- Then the status bar shows “Measuring” again and the device is in regular measuring operation again

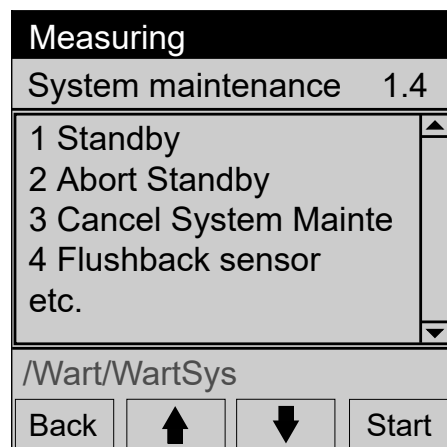

Figure 20: System maintenance menu

- 1 Standby**
Switches the system to Stand-by to put it out of operation for some time.
State: [see "Switch-off states", page 98](#)
- 2 Abort Standby**
Switches the system back to regular measuring operation.
(After it was switched to Standby using item “1” of this menu).
- 3 Cancel system maintenance**
Cancels a program started in this menu.
- 4 Flushback sensor**
Triggers a backflush of the probe tube (as well as the inlet filter when fitted on the probe tube) with instrument air.
 - Press “Start” to start the backflush.
 - Operating state: “Maintenance”.
 - The measuring screen appears with a downwards counter to the end of the adjustment.
 - The system switches back to operating state “Maintenance” when the adjustment has completed (when “Maintenance” was set manually beforehand: Back in “Maintenance”).
- 5 Leakage test**
Starts a leak tightness check: [see "Performing a leak tightness check", page 66](#)

6 **Test pressure sensors**

Checks the pressure sensors.

Perform a check when you have the impression that a pressure sensor is defective.

- “Test ok” means: The pressure sensors are OK
- “Test failed” means: One of the pressure sensors is defective. Replace the pressure control module: see "Replacing the pressure control module", page 83

7 **Adjust pressure sensors**

After replacing the pressure control module: Perform this menu item.

7.4.8 **Confirm messages**

This menu serves to confirm pending messages (menu: Diagnosis/Error Mess.).

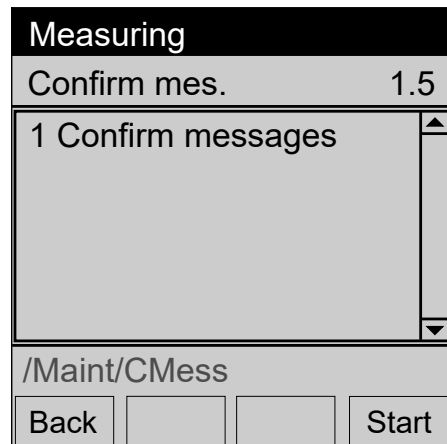

- 1 Confirm all pending messages

Figure 21: Confirm messages menu

7.5 **Adjustment**



NOTE

- Menu representation is optimized for the description and does not always correspond exactly to the actual representation on the display.
- All numeric values in the menus described here are examples without metrological significance
Realistic values depend on the individual device

7.5.1 **Span gas**

Menu: Adjustment/Span gas

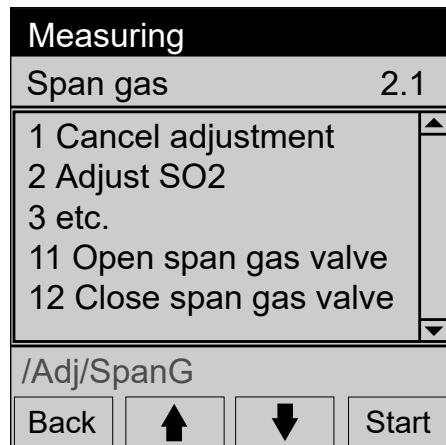

Figure 22: Span gas menu

- 1 **Cancel adjustment**
Cancel a running adjustment started in this menu.
The system returns to measuring operation.
- 2 **Adjust SO₂** (example)
 - Compare the set span gas concentration with the certificate of the span gas cylinder and, when necessary, change this in the device: see ["Span gas concentrations", page 27](#)
 - Switch the maintenance signal on when necessary: see ["Maintenance signals on/off", page 31](#)
- 3 Adjustment of further components corresponding to measured components in the device.
See above for procedure.
- 10 **Adjust O₂**
O₂ is adjusted using instrument air.
The device flushes automatically with instrument air and the oxygen content of the instrument air is used for measurement.
This sets the zero and reference points.
- 11 **Open span gas valve**
Open the span gas valve: The display (Measuring screen) shows the measured value of the span gas.
- 12 **Close span gas valve**
Close the span gas valve again.

7.5.2 Zero point

Menu: **Adjustment/Zero point**

This menu serves to validate or adjust the zero points of the measured values when feeding instrument air.

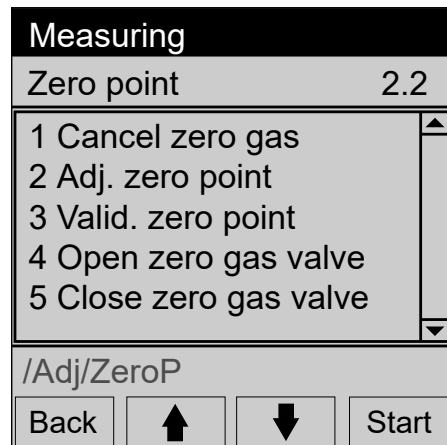

Figure 23: Zero point menu

- 1 **Cancel zero gas**
Cancels a check started in this menu.
The system returns to measuring operation.
- 2 **Adjust zero**
Starts zero point adjustment
Instrument air is fed automatically to the system.
An automatic zero point adjustment of all components then follows.
- 3 **Check zero gas**
Start zero point validation
Procedure as above but the measured values are only displayed and not corrected.
- 4 **Open zero gas valve**
Open the zero gas valve: The display (Measuring screen) shows the measured value of the zero gas.
- 5 **Close zero gas valve**
Close the zero gas valve again.

7.5.3 Internal adjustment

Menu: Adj./Internal adj.

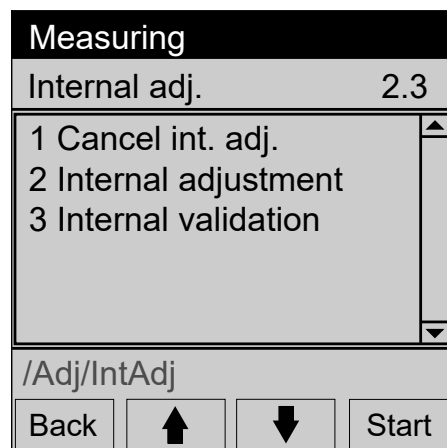

Figure 24: Internal adjustment menu

- 1 **Cancel internal adjustment**
Cancels a check started in this menu.
The system returns to measuring operation.

- 2 **Adjust internal**
Start an internal adjustment.
- 3 **Internal validation**
Start an internal validation.
Procedure as above but the measured values are not corrected.
Adjustment result: [see "Results", page 38](#).

7.5.4 Results

Menu: **Diagnosis/Results**

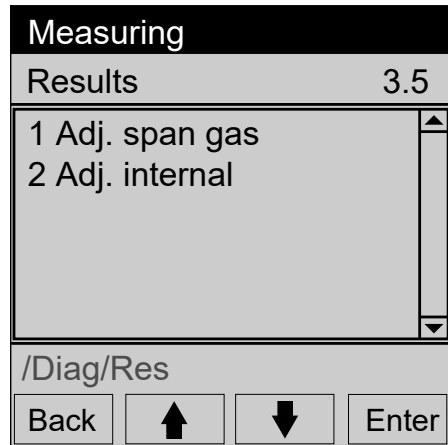

This menu serves to view the results of the adjustment procedure.

- 1 Span gas adjustment result
- 2 Adjustment with internal standard result

Figure 25: Results menu

7.5.5 Settings

Menu: **Adjustment/Settings**

7.5.5.1 Span gas concentrations

Menu: **Adjustment/Settings/Span gas**

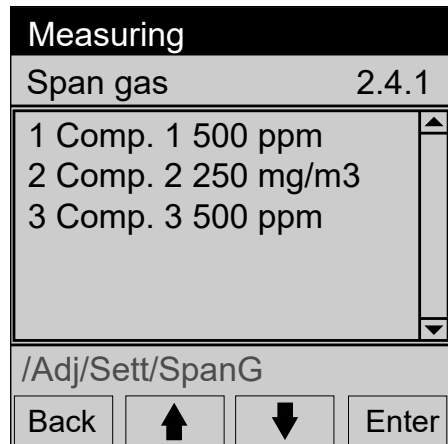

This menu serves to enter the concentrations of the span gases.

Figure 26: Span gas concentration menu

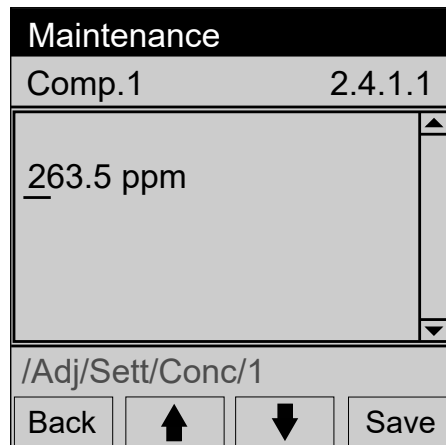

Figure 27: Concentration menu

7.5.5.2 Factors

Menu: Adjustment/Settings/Factors

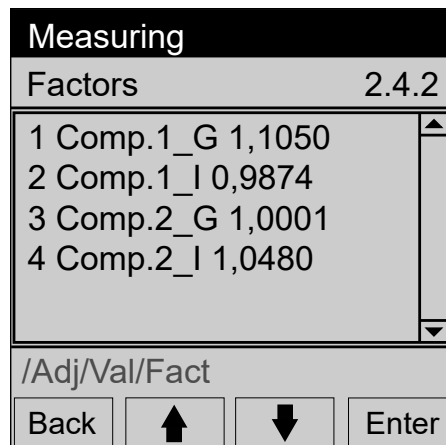

Figure 28: Main menu

This menu shows the current correction factors of the measuring components. There are 2 correction factors per component:

- _G: Correction factor for span gas.
- _I: Correction factor for internal adjustment standard (option).

7.6 Diagnosis



NOTE

- Menu representation is optimized for the description and does not always correspond exactly to the actual representation on the display.
- All numeric values in the menus described here are examples without metrological significance
Realistic values depend on the individual device

7.6.1 System info

Menu: Diagnosis/System info

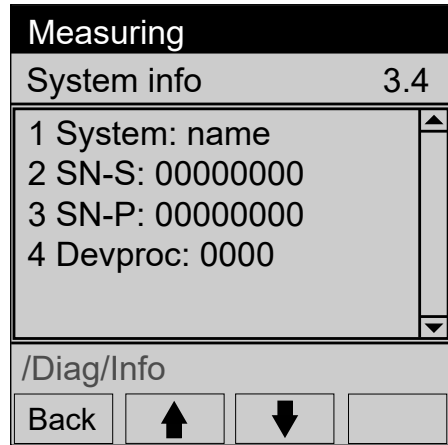

Figure 29: System info menu

This menu shows the device numbers and software versions.

- 1 System name
- 2 Serial number device
- 3 Serial number cell
- 4 Version device software
- 5 Etc.

7.6.2 Error messages

Menu: **Diagnosis/Error Mess.**

This menu shows the current pending messages.

Error messages: [see "Error messages and possible causes", page 112](#)

The messages can be reset, as required, after error clearance, in menu Maintenance/Confirm messages.

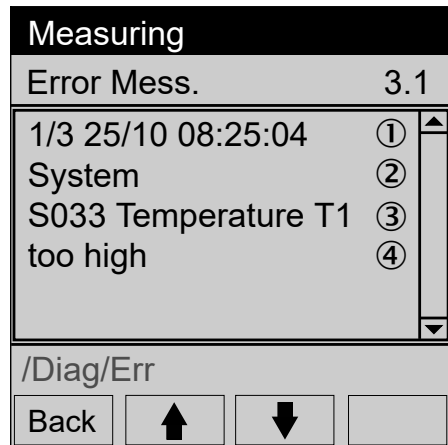
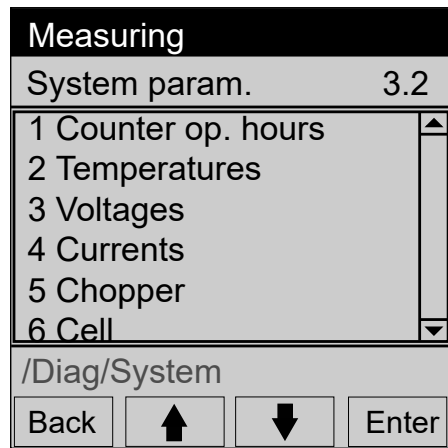

Figure 30: Error messages menu

- 1
 - Message number / number of pending messages
 - Date of occurrence (dd/mm)
 - Time of occurrence (hh:mm:ss)
- 2 Trigger (e.g.: System, measuring components, receiver)
- 3 Error number
Message list: [see "Error messages and possible causes", page 112](#)
- 4 Error message in plain-text

7.6.3 Device state data

Menu: **Diagnosis/System Param.**



This menu serves to view various system parameters.

- 1 Operating hours counter
- 2 Temperatures
- 3 Voltages
- 4 Currents
- 5 Chopper (internal component)
- 6 Cell
- 7 Reference energy

Figure 31: System parameters menu

7.6.3.1 Operating hours counter

This menu serves to view and reset, as required, diverse operating hours counters.

- ▶ Press the **Set** button to reset the counter
A safety prompt does not appear



CAUTION

Some operating hours counters output a message when the corresponding operating time elapses.

This concerns the operating hours counters for:

- “Light source”
- “Filter sampling unit”
- “Filter cell”
- ▶ Only reset these operating hours counters when the subassembly involved has been replaced.
Otherwise no message is output at the actual expiry time

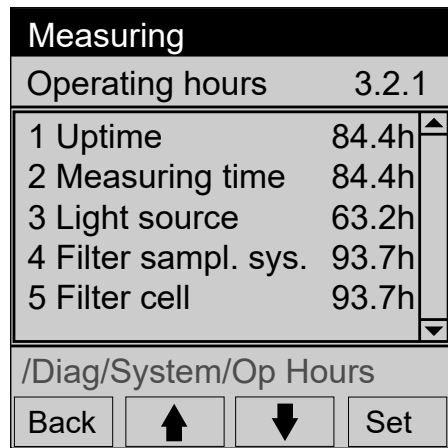

Figure 32: Operating hours counter menu

- 1 Operating hours
This counter shows the total operating time (“Power on”) of the Analyzer module.
Let SICK Customer Service reset this counter.
- 2 Measuring time
This counter shows the total time sample gas was fed.
- 3 Operating time of the IR source
Only reset this operating hours counter when the subassembly involved has been replaced.
- 4 Operating time of the filter of the gas sampling system
Only reset this operating hours counter when the subassembly involved has been replaced.
- 5 Operating time of the cell inlet filter
Only reset this operating hours counter when the subassembly involved has been replaced.

7.7 Configuring



NOTE

- Menu representation is optimized for the description and does not always correspond exactly to the actual representation on the display.
- All numeric values in the menus described here are examples without metrological significance
Realistic values depend on the individual device

7.7.1 Sprache / Language

Menu: Language

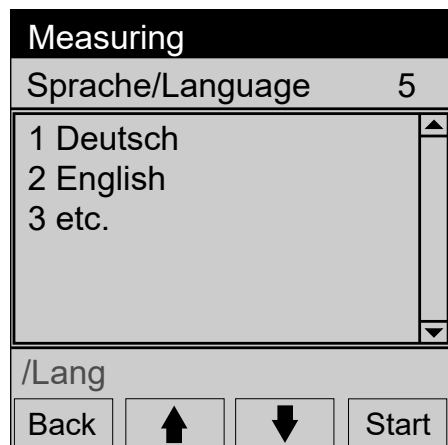

Figure 33: Language menu

This menu serves to select the menu language.

7.7.2 Date and time

Menu: Parameter/Date/Time

This menu serves to view the date and time.

Setting the date and time: See “MARSIC300 Technical Information”.

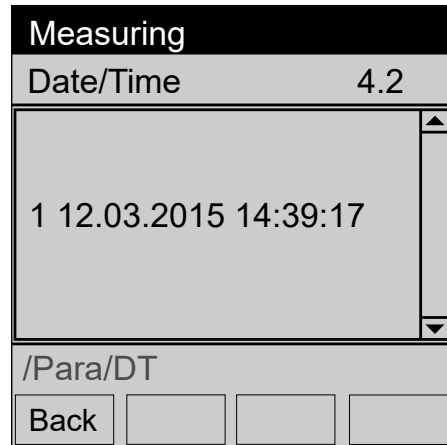

- 1 Display date in format dd.mm.yyyy
Display time in format hh:mm:ss
The format depends on the country.

Figure 34: Date menu

7.7.3 Display

7.7.3.1 Measured values

This menu serves to select measuring components from a system-specific list to be shown on the device display.

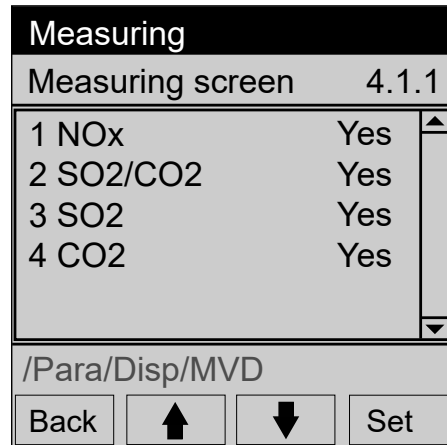

- Yes: Display component
- No: Do not display component

Figure 35: Menu Measuring Screens

7.7.3.2 Scaling 1/2

Menu: Parameter/Display/Scaling 1 - 8

Menu: Parameter/Display/Scaling 9 - 16

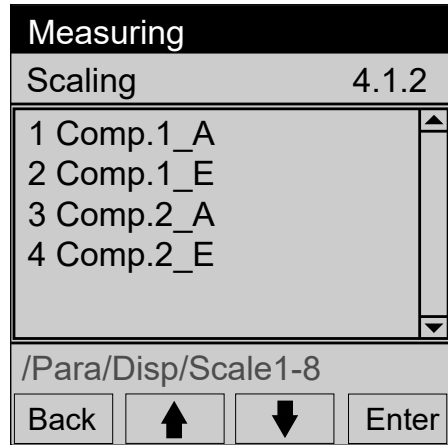

Figure 36: Menu Scaling

This menu serves to scale bar graph and line diagrams. The specified scaling is valid for both diagrams. Update interval for graphic: 1 second

- 1 _A: Scaling start value for component 1
- 2 _E: Scaling end value for component 1
- 3 _A: Scaling start value for component 2
- 4 _E: Scaling end value for component 2

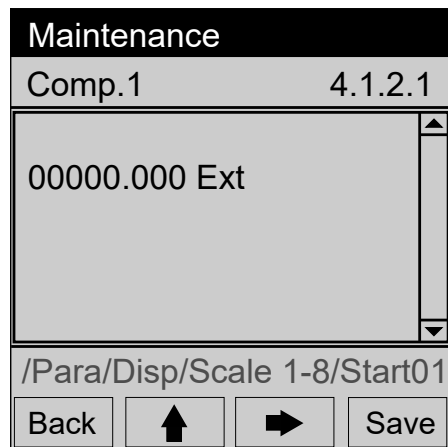

Figure 37: Maintenance menu

Enter numeric value.

For minus character: As first digit: Press ↑ 10 times.

Invalid entries are not accepted (start value > end value).

7.7.3.3 Time axis

Menu: Parameter/Display/Timeline

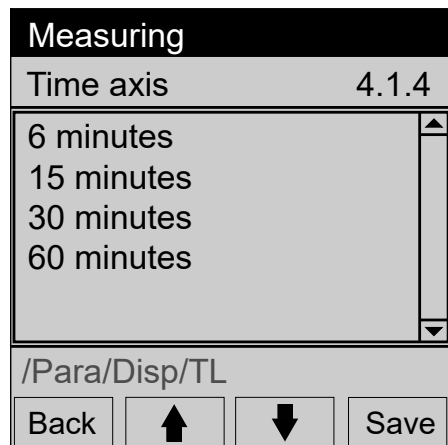

Figure 38: Time axis menu

This menu serves to scale the time axis of the line diagram.

Update interval for graphic: Depending on the scaling: see "Scaling 1/2", page 43

Enter: Time axis end value

7.7.4 I/O configuration

Menu: Diagnosis/I/O configuration

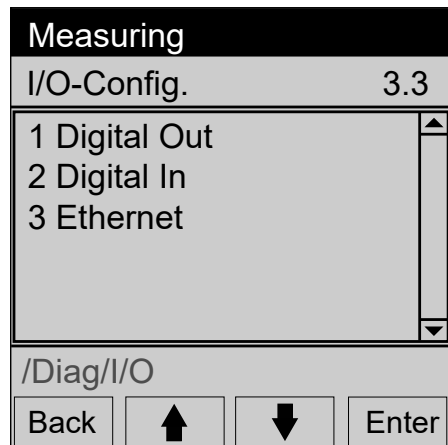

This menu serves to view the configuration of the data interfaces.

- 1 Digital outputs
- 2 Digital inputs
- 3 Ethernet

Figure 39: I/O configuration menu

7.7.5 Sampling point switchover

Menu: Parameter/Meas. points

For systems with sampling point switchover:

This menu serves to configure sampling point switchover.

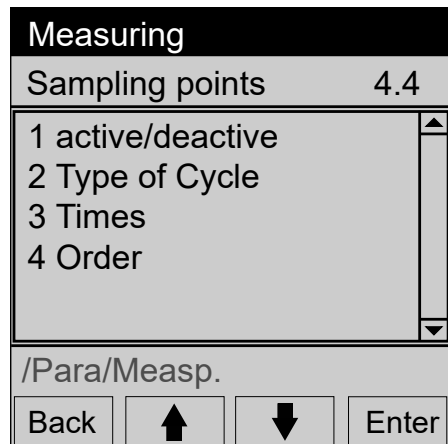

- 1 Activate/deactivate the desired sampling point.
- 2 Set the cycle type.
- 3 Configure the cycle times.
- 4 Configure the sampling points sequence.

Figure 40: Sampling points menu

7.7.5.1 Activate/deactivate sampling points

Menu: Parameter/Meas. points/active/inactive

This menu serves to activate/deactivate sampling points.

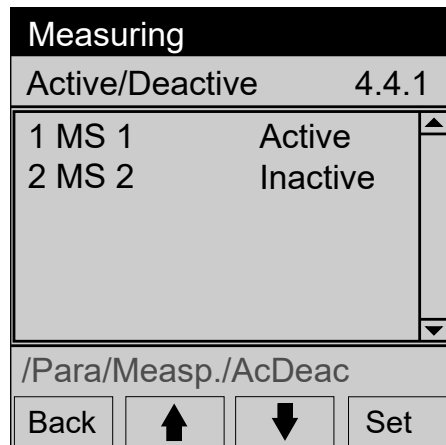

- 1 Activate/deactivate sampling point 1
- 2 Activate/deactivate sampling point 2
- 3 etc.

Figure 41: Activating/deactivating sampling points menu

7.7.5.2 Cycle type

Menu: Parameter/Meas. points/Type of Cycle

This menu serves to configure the cycle type of the sampling points.

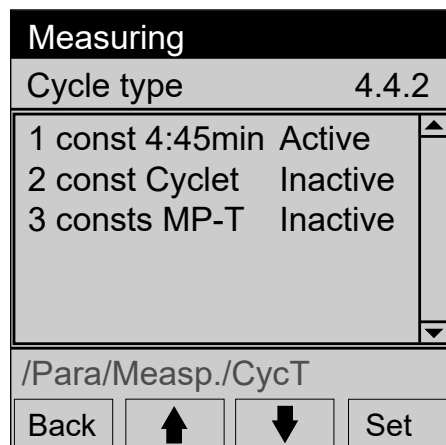

- 1 Measures all active sampling points with the cycle time specified here. This cycle time can not be changed. The cycle time is valid for all sampling points together.
const = constant
- 2 Measures all active sampling points with the cycle time set in menu **Parameter/Meas. points/Times** under ①. The cycle time is valid for all sampling points together.
- 3 Measures with an individual time for each sampling point. The respective time is set in menu **Parameter/Meas. points/Times** under ② etc.

Figure 42: Cycle type menu



NOTE

Max. 2 sampling points within 4:45 minutes (Scheme B) for MEPC.259(68)

7.7.5.3 Times for sampling points

Menu: Parameter/Meas. points/Times

This menu serves to configure the times for one measurement.

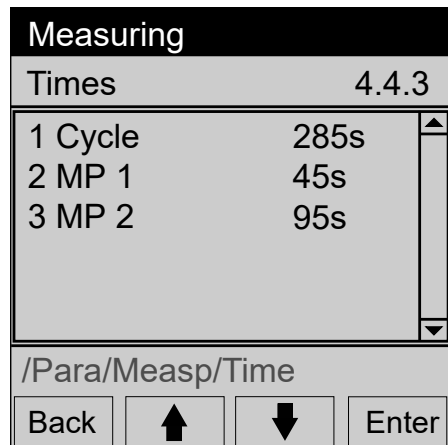

- 1 Enter the cycle time for a complete measurement (all active sampling points).
- 2 Enter the measuring time for sampling point 1.
- 3 Enter the measuring time for sampling point 2.

Figure 43: Times menu



NOTE

Max. 2 sampling points within 4:45 minutes (Scheme B) for MEPC.259(68)

7.7.5.4 Sampling point sequence

Menu: **Parameter/Meas. points/Order**

This menu serves to configure the sequence of the sampling points.

Example:

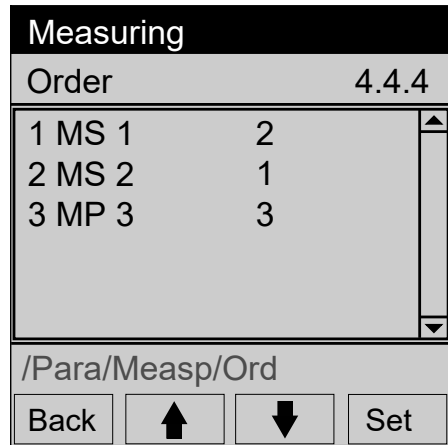

- 1 Configure: Sampling point 1 is measured second
- 2 Configure: Sample point 2 is measured first
- 3 Configure: Sampling point 3 is measured third

Figure 44: Sequence menu

7.7.6 Sampling point name

Menu: **Parameter/Sampling point name**

This menu shows the system installation location (e.g. "Stack 1").

Configuration: See "MARSIC300 Technical Information".

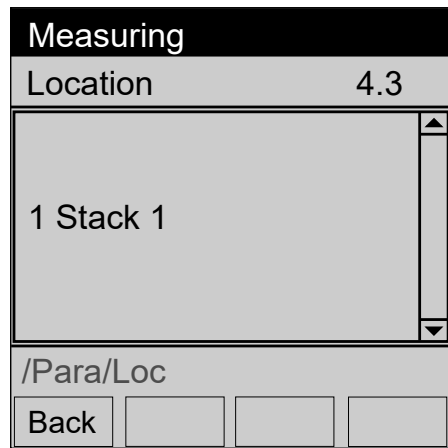

Figure 45: Location menu

8 Maintenance

8.1 Important Information

Requirements on the maintenance personnel

- The technician must be familiar with the exhaust gas technology of the operator's plant (hazard by overpressure and toxic and hot flue gases) and be able to avoid hazards when working on gas ducts
- The technician must be familiar with handling compressed gas cylinders (span gases)
- The technician must be able to avoid hazards caused by noxious span gases
- The technician must be familiar with gas lines and their screw fittings (be able to ensure gas-tight connections)
- Only electricians are permitted to work on the electrical system or electrical sub-assemblies



NOTICE

Pay attention to voltage variants

Some spare parts are available in different voltage variants, 115 V or 230 V.

- ▶ Check spare parts for voltage dependency before fitting: [see "Power supply", page 105](#).

The power voltage of your system is shown on the type plates.



CAUTION

Hazard of severe damage to electronic subassemblies through electrostatic discharge (ESD)

When touching electronic subassemblies, there is a hazard of severe damage to the subassembly by electric potential equalization.

- ▶ Make sure you have the same electric potential as the subassembly (e.g. by grounding) before touching the subassembly.



CAUTION

Risk of chemical burns by acid gas

- ▶ Acid condensate can escape when working on the sample gas lines and the associated subassemblies
- ▶ Take appropriate protective measures for work (for example, by wearing a safety mask, protective gloves and acid resistant clothes)
- ▶ In case of contact with the eyes, rinse immediately with clear water and consult a doctor



CAUTION

Risk of contamination of analyzer

The gas sampling system and analyzer are flushed with instrument air when the system is not in measuring operation.

The analyzer can be contaminated when instrument air is switched off.

- ▶ Take the gas sampling system out of the exhaust duct when instrument air is not available for a longer period of time ([see "Replace gas sampling system", page 70](#))

Observe the following:

- ▶ After working on the gas path: Perform a leak tightness check: see "Performing a leak tightness check", page 66
- ▶ After exchanging subassemblies: Switch the system on according to the switch-on procedure: see "Switching on", page 19
- ▶ After exchanging a span gas cylinder: Check the compliance with the span gas concentration set in the menu: see "Span gas concentrations", page 27



NOTE

Consumable parts, wearing parts and spare parts: see "Consumable parts, wearing parts and spare parts", page 119

8.1.1 Information on span gases



NOTICE

Before working on span gas cylinders or span gas lines: Relieve the span gas pressure.

- ▶ Shut off the span gas cylinder.
- ▶ Open the span gas valve: Menu: **Adjustment/span gas**.
- ▶ Wait for about 1 minute until the pressure in the lines has been relieved.
- ▶ Close the span gas valve: Menu: **Adjustment/span gas**.

8.1.2 Tube screw fittings

Clamping ring screw connection

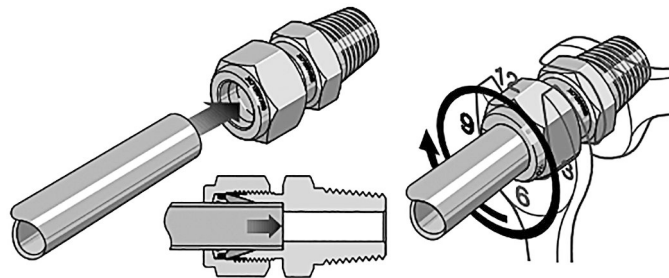

Figure 46: Clamping ring screw connection

- ▶ Push the tube up to the stop in the tube screw fitting. Turn the cap nut finger-tight.
- ▶ During initial assembly: Hold the fitting bolt steady and tighten the cap nut with 1 1/4 revolutions.
- ▶ During refitting: Tighten the cap nut to the previous position (the resistance increases noticeably) and then slightly tighten.

Push-in fitting (pneumatic)

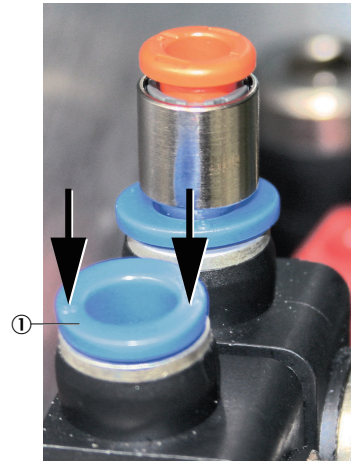

Figure 47: Push-in fitting with retaining ring

① Retaining ring

- ▶ Inserting the tube: Push tube in.
- ▶ Removing the tube: Press the retaining ring in and pull the tube out.

It is easier to press the retaining ring in using the pressure tool provided.



Figure 48: Pressure tool usage

Pressure tool

8.2 Maintenance plan



NOTICE

This Maintenance plan describes the maintenance work specified by the manufacturer. Inspections according to the Guidelines to be implemented by the operating company (e.g., MARPOL Annex VI) must be performed in accordance with the intervals described therein.



NOTE

Spare parts list: [see "Consumable parts, wearing parts and spare parts", page 119](#)

Table 9: Maintenance intervals

Interval ¹	Maintenance work	Remark
1W	Check pending messages (control unit).	see "Error messages and possible causes", page 112
	Check external instrument air conditioning (optional)	Refer to the Instrument Air Conditioning Operating Instructions
1M	Check system	see "Check system", page 52
	Gas sampling system: <ul style="list-style-type: none"> ● Check glass fiber filter and seals. ● Clean or replace as necessary. 	see "Gas sampling system maintenance", page 54
	One filter pad each in the fan and air outlet <ul style="list-style-type: none"> ● Check ● Clean or replace as necessary 	see "Replacing the filter pads", page 54
6M	Perform a leak tightness check	see "Performing a leak tightness check", page 66

Interval ¹	Maintenance work	Remark
1Y	Gas sampling system: <ul style="list-style-type: none"> • Replace the glass fiber filter and seals. • Replace the non-return valve • Remove soiling inside and outside 	see "Gas sampling system maintenance", page 54
	Check the H ₂ O correction	see "Performing an H₂O check", page 67
2Y	Replace on the cell: <ul style="list-style-type: none"> - non-return valve - sample gas inlet filter 	see "Replacing the cell filter non-return valve", page 62 see "Cell inlet filter maintenance", page 60
3Y	Replace IR source	see "Replace IR source", page 63
	Replace drying agent	see "Replacing the drying agent", page 59

¹ 1D = Daily, 1W = Weekly, 1M = Monthly, 3M = Every 3 months, 6M = Every 6 months, 1Y = Yearly, 2Y = Every 2 years, 3Y = Every 3 years

After exchanging the IR source, perform an adjustment with span gas (see the entry in the corresponding Maintenance plan).

Recommendation

We recommend sending the Analyzer module to SICK Customer Service every 2 years for maintenance.

The Analyzer module is then cleaned, overhauled and adjusted at the factory.

Alternatively, you can have the maintenance done as a customer service on board.

This then replaces the 2 and 3 year maintenance work.

Call the hotline number on the analyzer in this case.

8.3 Check system

Check subassemblies

- Check all fastening screws of the housing for tight seat
- Check sample gas line for outside damage
- Check sample gas outlet for continuity
- Check all tube fittings for tight seat
- Check system cabinet for cleanness, dryness and freedom from corrosion
- Check all electric connections for freedom from corrosion and firm seat
- Check grounding conductors are free from corrosion
- Check valve block and pressure reducer unit for leak tightness:
 - No hissing noise should be noticeable
 - Check no air is escaping from the connections, e.g., with leakage spray
- Check pressure settings on the pressure reducer unit: [see "Setting the pressure reducer module", page 59](#)

Check external instrument air conditioning

- Check pressure, oil, particle and water content according to the specification ([see "Supply gases", page 110](#))
- If external instrument air conditioning is fitted:
 - Check condition of filters: Refer to the Instrument Air Conditioning Operating Instructions provided

Check the span gas

- Check span gas (when used)
 - Use-by date
 - Fill level
 - Condition of cylinders

Check environment

- Check room ventilation
- Check ambient conditions of analyzer and gas sampling system: Temperature, humidity, vibrations

Check the gas sampling system

- Visually check state from the outside and clean as necessary
- Check sample gas line for outside damage

Check measured values (when system in operation)

- Check display of the control unit for pending error messages
- Check measured values for plausibility
- Check external instrument air conditioning

8.4 Instrument air conditioning maintenance

Perform maintenance on instrument air conditioning (external, optional).

1. Switch analyzer to “Stand-by”: [see "System maintenance", page 34](#)
2. Flush system for 10 minutes in this state
3. Close off operator's instrument air supply

**NOTICE**

Probe tube is not flushed without instrument air

- ▶ Only close off instrument air supply for a short time (several minutes)

4. Perform maintenance on the instrument air conditioning according to the provided manufacturer's instructions
5. Open instrument air supply again
6. Switch standby off again

External instrument air conditioning (optional)

1. Check the external instrument air conditioning for condensate.

**NOTICE**

- ▶ The condensate level must not exceed the “Maximum” mark.
-

8.5 Replacing the filter pads



Figure 49: Fan grill position

- ① Fan grill, top and bottom



Figure 50: Fan grill

The top and bottom filter pads are identical.
The analyzer does not have to be switched off.

1. Take fan grill off.
2. Take filter pad out.
3. Lay a new filter pad in immediately.
4. Press air fan back on.

8.6 Gas sampling system maintenance

8.6.1 Important Information



WARNING

Health risk through dangerous sample gas.

If dangerous sample gas is applied to the SFU: The operator is responsible for safe handling of sample gas.

- ▶ In addition to these Operating Instructions, observe all local laws, technical rules, and company-internal instructions valid at the site where the SFU is installed.
- ▶ Operate the SFU only in rooms with adequate installation OR install suitable gas monitoring equipment.
- ▶ Channel sample gas off safely.



WARNING

Hazard due to sample gas pressure.

The stacks can have underpressure or overpressure.

- ▶ Observe information from the plant operator.

**WARNING**

Risk of burns on hot surfaces.

Filter housing, flanges and sample gas lines can be hot.

- ▶ Before starting any work on the device parts, allow the surfaces to cool down to body temperature or wear appropriate protective gloves.

**WARNING**

Danger to life by electric voltage

- ▶ Only allow an authorized electrician to work on the electric system

**WARNING**

Hot surfaces

Risk of burns when touching the surfaces

- ▶ Switch analyzer off and allow to cool down

or

- ▶ Wear suitable protective clothes, for example, heat-resistant gloves.

1. Switch analyzer to "Maintenance": [see "Maintenance signals on/off", page 31.](#)
2. Switch analyzer to "Stand-by": [see "System maintenance", page 34.](#)
3. Flush system for 10 minutes in this state.
4. Perform maintenance work on the gas sampling system: See the provided "Gas Sampling System SFU Operating Instructions"
When the gas sampling system needs to be removed: Switch external instrument air off.
5. Reset operating hours counter (menu: Diagnosis/System param./Counter Op. Hrs./Filter sampling system)
6. Reset stand-by and maintenance signal again.

Exchanging the glass fiber fine filter

You can perform the work while the filter element is hot.

Pay attention to the warning about hot surfaces.

The filter can have an internal temperature of 185 °C.

Replacing fine filter cartridge

1. Loosen the rotary handle counterclockwise.

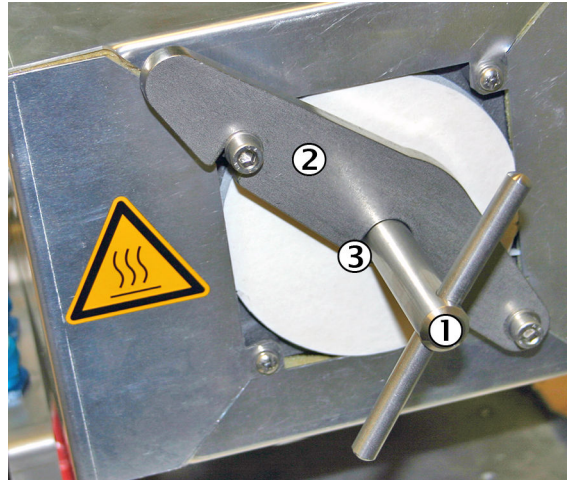

- ① Rotary handle
- ② Mounting bracket
- ③ Pressure disk (covered)

2. Swing the mounting bracket to the right.



WARNING

Risk of burns on hot surfaces

The filter element can reach high temperatures in operation.

- ▶ Wear suitable gloves.
- ▶ Provide a heat-resistant support.



CAUTION

Risk of injury due to high weight

- ▶ Do not drop the filter cover.

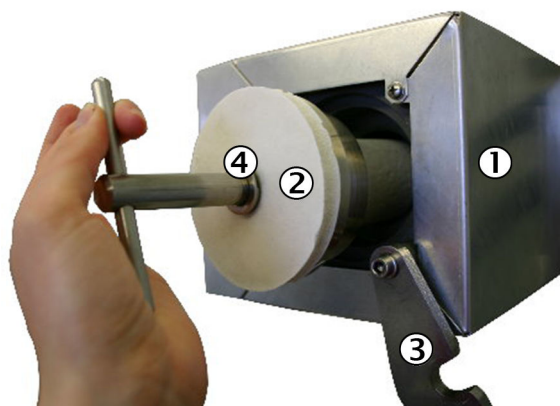

- ① Filter housing
- ② Filter cover
- ③ Mounting bracket
- ④ Pressure disk

- 3. Pull out the filter cover with glass fiber filter element using the rotary handle.
- 4. If the filter cover is hot: Place the filter cover on a heat-resistant mat.
- 5. Pull out the bottom flat seal with a hook.

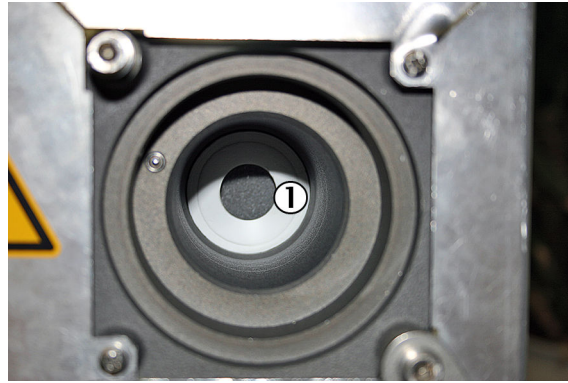

① Bottom flat seal

6. Loosen the glass fiber filter element from the filter handle by opening the spiral thread.

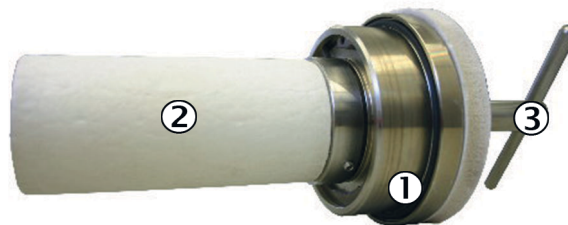

① O-ring
 ② Glass fiber filter element
 ③ Rotary handle

7. Insert new bottom flat seal.
8. Renew the O-ring in the filter cover.
9. Fit new or cleaned glass fiber filter element on the filter cover. Tighten the spiral thread.
 If one side of the filter element has a groove: The groove must point in the direction of the filter cover.
10. Replace the filter cover.

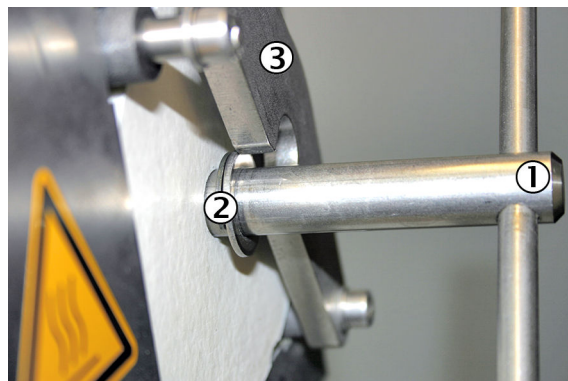

① Rotary handle
 ② Pressure disk
 ③ Mounting bracket

11. Swing back the mounting bracket. Make sure that the pressure disk is behind the mounting bracket.
12. Tighten the rotary handle clockwise.

Exchanging the non-return valves

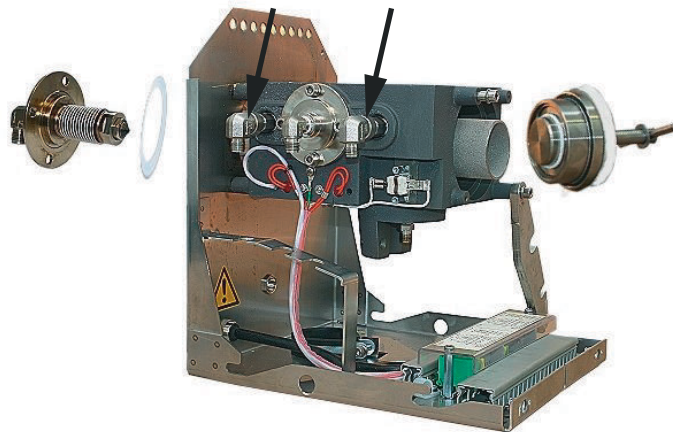

Figure 51: Gas sampling unit

Two non-return valves are fitted underneath the sheet cover in the valve block:

1. Remove the 90° screw fittings and the insulation.
2. Fit new valves with Teflon tape.



NOTICE

Observe the alignment of the non-return valves

- Arrow must point towards the housing

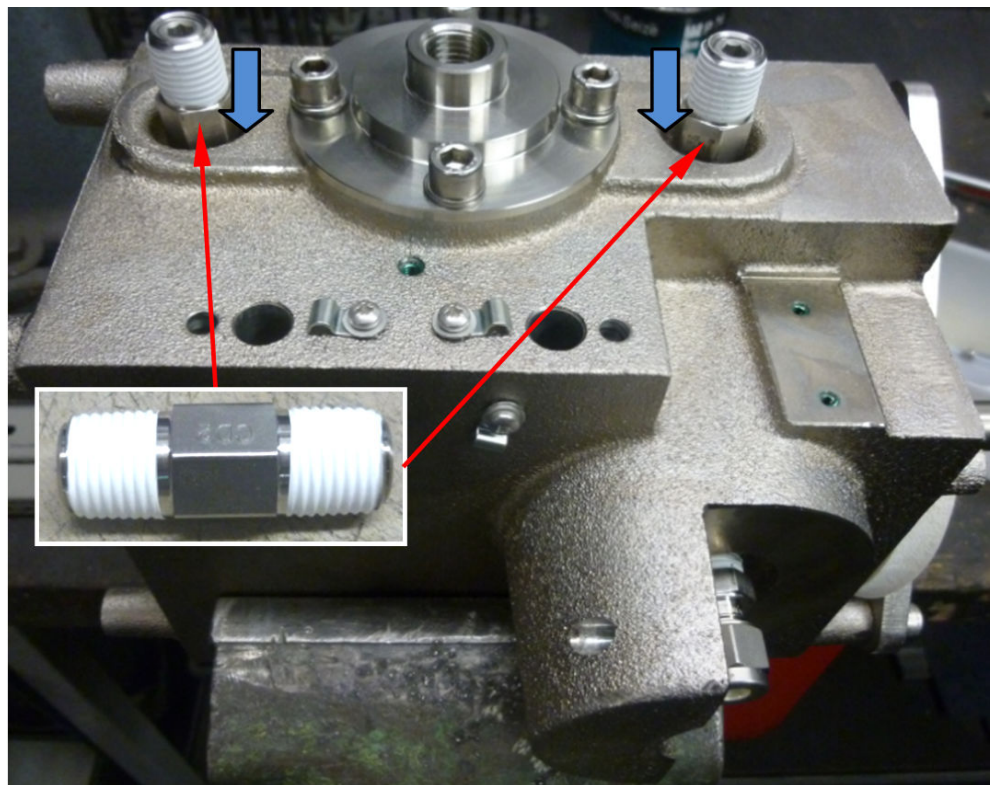

Figure 52: Position of non-return valves

3. Perform a leak tightness test after completing the work.

8.7 Replacing the drying agent

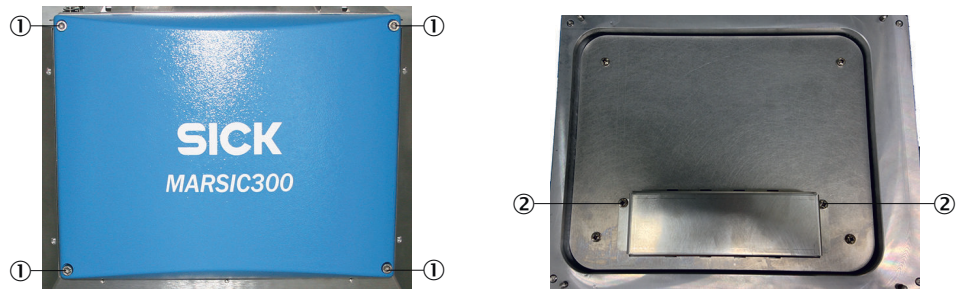

Figure 53: Replacing the drying agent

- ① Screws on blue analyzer cover
- ② Screws on drying agent container



WARNING

Hot surfaces

Risk of burns when touching the surfaces

- ▶ Switch analyzer off and allow to cool down

or

- ▶ Wear suitable protective clothes, for example, heat-resistant gloves.

You can perform the work while the filter element is hot.

1. Unscrew 4 screws on blue analyzer cover
2. Take cover off
3. On cover rear side: Unscrew 2 screws of drying agent container
4. Replace drying agent
5. Screw drying agent container back on
6. Screw cover back on

8.8 Setting the pressure reducer module

The external air supply is fitted on the pressure reducer module.

- ▶ Set the controllers to the pressures shown in the Figure.



Figure 54: Pressure reducer unit

- ① Instrument air inlet with zero gas quality
- ② Instrument air inlet for induction air ejector only
- ③ Manual valve for instrument air selection

- ④ 3 pressure reducers (adjustable)
- ⑤ Manual valve - closed position
- ⑥ Manual valve - open position

The instrument air is used as both induction air for the ejector (cell) and zero/control air.

There are two possibilities of connecting instrument air:

- ▶ One (1) common instrument air supply for ejector air and zero/control air (inlet 1)
- ▶ Separate instrument air supply for:
 - Ejector air (inlet 2)
 - and zero/control air (inlet 1)

Instrument air quality

The quality requirement for instrument air used exclusively as ejector air is lower than for usage as zero/control air (zero gas quality) (see "Supply gases", page 110).

- ▶ When connected just as instrument air supply with zero gas quality to be used as common air for both ejector air and zero/control air (on inlet 1):
 - ▶ Set manual valve to position "open".
- ▶ When connected as (1) instrument air supply for the ejector (on inlet 2) and as instrument air supply with zero gas quality (on inlet 1):
 - ▶ Set manual valve to position "closed".

8.9 Cell inlet filter maintenance

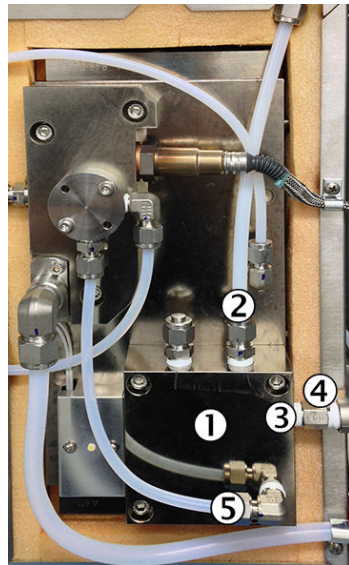

Figure 55: Cell open

- ① Cell inlet filter
- ② Sample gas inlet
- ③ Span gas inlet
- ④ Non-return valve
- ⑤ Connecting tube

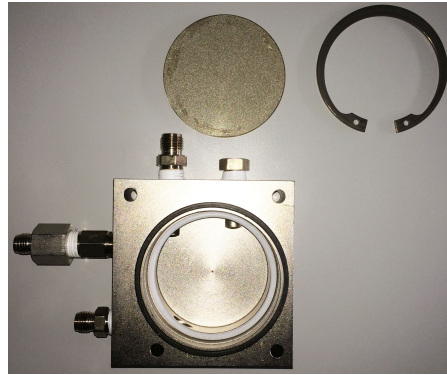

Figure 56: Filter with seal

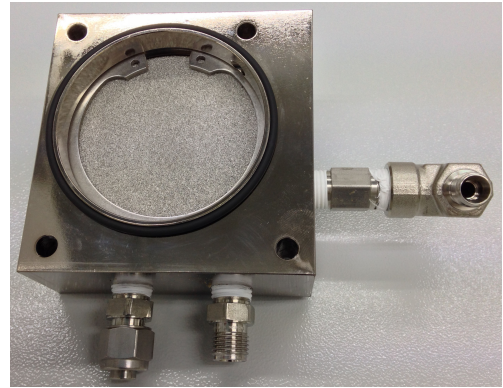

Figure 57: Filter

- ▶ Switch analyzer to “Stand-by”: see "System maintenance", page 34
- ▶ Flush system for 10 minutes in this state
- ▶ Switch system off at the external power disconnection unit



WARNING

Hot surfaces

Risk of burns when touching the surfaces

- ▶ Allow cell to cool down

Removing

1. Open cell cover (loosen 4 screws on the side)
2. Unscrew 3 tube connections on cell inlet filter:
 - Sample gas line (and second sample gas line as necessary)
 - Span gas line
 - Connecting tube
3. Unscrew cell inlet filter (4 screws) and remove, lever off carefully when necessary
4. Take O-ring off (seal)
Clean sealing surface carefully with a suitable scraper
5. Take retaining ring off with circlip pliers
6. Remove sintered metal filter and dispose of in a suitable manner
7. Remove seal (white) under the sintered metal filter and dispose of in a suitable manner
8. Clean filter housing

Fitting

1. Lay new seal (white) in the filter housing
2. Lay new sintered metal filter in
3. Fit new retaining ring
 - Check for correct seating of the filter and retaining ring as well as the seals
4. Lay O-ring (seal) in again
5. Refit filter housing



NOTICE

Screws can seize.

- ▶ Use high temperature grease
For example, BARRIERTA @L55 (SICK Part No.: 5602979)

6. Fit 3 tubes back on
7. Close cell cover

- ▶ Switch system on again at the external power disconnection unit: [see "Switching on", page 19](#)
- ▶ When the system is ready for operation: Perform a leak tightness check: [see "Performing a leak tightness check", page 66](#)
- ▶ Reset operating hours counter (menu: Diagnosis/System param./Counter Op. Hrs./Filter cell)

8.10 Replacing the cell filter non-return valve

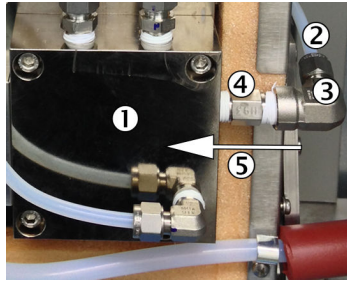

Figure 58: Cell open

- ① Cell inlet filter
- ② Span gas line
- ③ Bracket piece
- ④ Non-return valve with flow direction (arrow)
- ⑤ Flow direction



Figure 59: Non-return valve with flow direction symbol

Return valve with flow direction symbol

- ▶ Switch analyzer to “Stand-by”: [see "System maintenance", page 34](#)
- ▶ Flush system for 10 minutes in this state
- ▶ Switch system off at the external power disconnection unit



WARNING

Hot surfaces

Risk of burns when touching the surfaces

- ▶ Allow cell to cool down

Removing

1. Open cell cover
2. Unscrew tube connection of span gas line on the bracket piece
3. Loosen bracket piece on non-return valve and remove
4. Unscrew non-return valve on cell inlet filter
5. Clean Teflon residues on threads in bracket piece and cell inlet filter

Fitting

1. Wrap Teflon tape on both threads of the new non-return valve
2. Screw non-return valve back into the cell inlet filter

**NOTICE**

- ▶ Observe flow direction of valve and installation (see Figure above)
-
3. Screw bracket piece back onto the non-return valve
 4. Reconnect span gas line
 5. Close cell cover
 6. Perform a leak tightness check: [see "Performing a leak tightness check", page 66](#)
 7. Reset stand-by and maintenance signal
- ▶ Switch system on again at the external power disconnection unit: [see "Switching on", page 19](#)
 - ▶ When the system is ready for operation: Perform a leak tightness check: [see "Performing a leak tightness check", page 66](#)
 - ▶ Reset operating hours counter (menu: Diagnosis/System param./Counter Op. Hrs./Filter cell)

8.11 Replace IR source**WARNING**

Health risk through dangerous sample gas

If dangerous sample gas is applied to the SFU: The operator is responsible for safe handling of sample gas.

- ▶ In addition to these Operating Instructions, observe all local laws, technical rules, and company-internal instructions valid at the site where the SFU is installed.
- ▶ Operate the SFU only in rooms with adequate installation OR install suitable gas monitoring equipment.
- ▶ Channel sample gas off safely.

**WARNING**

Hazard through sample gas pressure

The stacks can have underpressure or overpressure.

- ▶ Observe information from the plant operator.

**WARNING**

Risk of burns on hot surfaces

Filter housing, flanges and sample gas line can be hot.

- ▶ Allow the surface of the device parts to cool down to body temperature or wear suitable protective gloves.

**WARNING**

Danger to life by electric voltage

- ▶ Only allow an authorized electrician to work on the electric system.



WARNING

Risk of burns on hot surfaces

The filter element can reach high temperatures in operation.

- ▶ Wear suitable gloves.
- ▶ Provide a heat-resistant support.



WARNING

Hazard by toxic substances

Filter elements can contain toxic substances depending on the sample gas composition.

- ▶ Observe the relevant safety regulations.
- ▶ Dispose of the filter elements in an environmentally compatible manner.

- ▶ Switch analyzer to “Stand-by”: [see "System maintenance", page 34](#)
- ▶ Flush system for 10 minutes in this state
- ▶ Switch system off at the external power disconnection unit

Removing



Figure 60: Blue cover

- ① Screws on blue cover

1. Unscrew the 4 screws on the blue cover just enough until they are loose
2. Take blue cover off

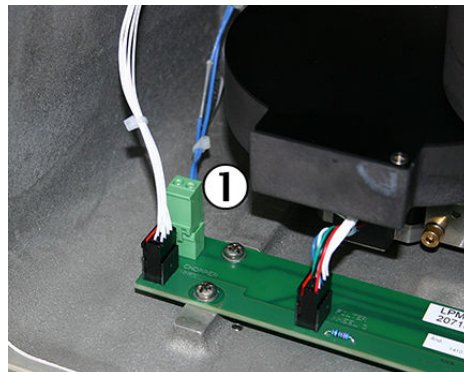

Figure 61: Plug on IR source circuit board

- ① IR source plug

3. Disconnect green plug with blue lead (IR source plug) on the circuit board

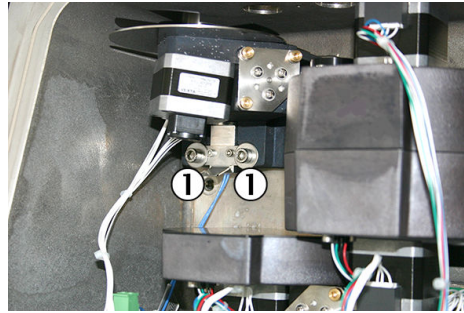

Figure 62: IR source screws

- ① 2 screws, IR source socket

4. Loosen 2 screws on IR source socket about 1 turn
At the same time, hold the IR source on the metal handle

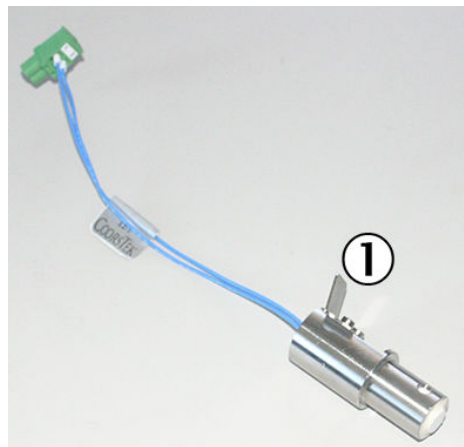

Figure 63: IR source

- ① Metal handle on IR source

5. Take IR source out downwards

Fitting

1. Insert IR source upwards into the IR source socket
Push IR source right up to the top and make sure the IR source is at the stop
2. Push IR source tight upwards and screw 2 screws on IR source socket tight
3. Insert blue lead again
4. Replace drying agent: [see "Replacing the drying agent", page 59](#)
5. Fit blue cover (observe guide pins)
6. Screw blue cover tight
7. Switch system on again at the external power disconnection unit: [see "Switching on", page 19](#)
8. Perform adjustment with span gas: Menu "Adjustment/Span gas"
9. Reset operating hours counter (menu: Diagnosis/System param./Counter Op. Hrs./Light source)

8.12 Performing a leak tightness check



WARNING

Risk of burns on hot cell

The cell is very hot (approx. 200 °C).

For the leak tightness check, the line on the sample gas outlet must be unscrewed when the cell is hot.

- ▶ Use heat-resistant gloves.
- ▶ Use heat-resistant tool.



NOTICE

Only perform the leakage test when the device is running.

1. Start program **Maintenance/Maintenance Sys./Leakage Test**.
2. Wait until message “Close outlet - discon. purge” appears.

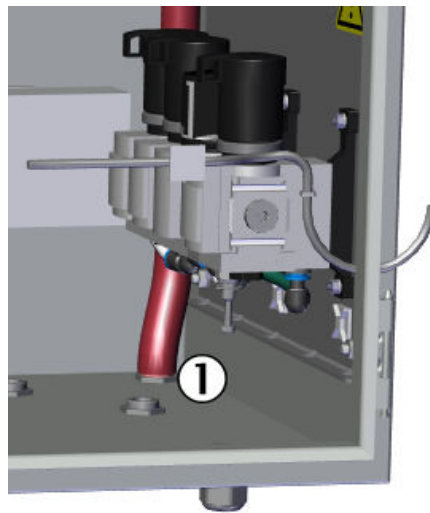

Figure 64: Sample gas outlet (inside view)

- ① Sample gas outlet

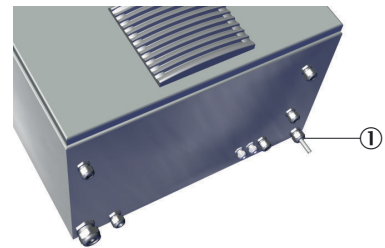

Figure 65: Measuring outlet (exterior view)

- ① Sample gas outlet at bottom rear of the housing

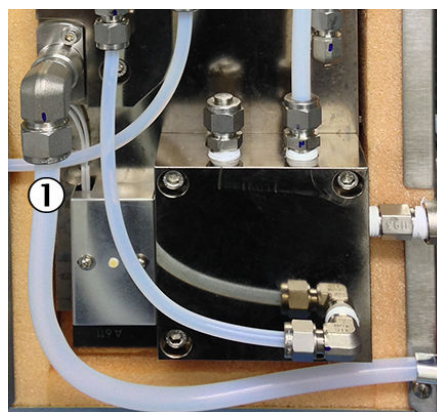

Figure 66: Measuring outlet - cell

- ① Sample gas outlet on cell

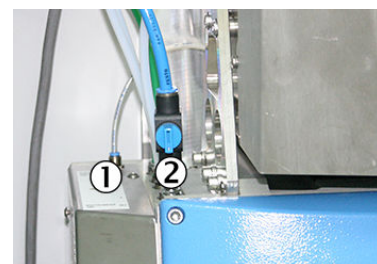

Figure 67: Analyzer module - connections

- ① Rear (thin) flush air line
- ② Instrument air valve (shown "open")

3. On Analyzer module: Disconnect rear purge air line (press ring to do so).
4. Close off sample gas outlet gas-tight:

- Either at the end of the sample gas outlet line (the line does not end at the housing duct but runs through to the cell in the housing).
The leak tightness check set has a suitable plug to close off the sample gas outlet line.
 - Or on the cell at the sample gas outlet (10 mm clamping ring sealing plug, the plug is also in the leak tightness test set).
To do this, open the cell: Loosen 4 side screws and remove cover.
5. The pressure in the system slowly rises.
Message “close air valve” appears when the pressure is ≥ 1200 hPa (after about 30 seconds) (the current pressure is shown in the “Measured value display”).
 6. Close instrument air valve.
 - The pressure no longer rises and measurement starts automatically after about 20 seconds: Measurement duration approx. 5 minutes.
 - Pressure loss during this time must not exceed 20 hPa. A message is shown:
 - “Test OK - open air valve”: Test successful.
 - “Test failed - open air valve”: Test unsuccessful: Analyzer switches to “Maintenance request” state.
 7. Open instrument air valve again.
 8. Wait until message “Reopen outlet - connect purge” appears.
 9. Reconnect rear purge air line.
 10. Restore sample gas outlet to its original state.

8.13 Performing an H₂O check



NOTICE

Carry out the check of the H₂O correction once a year. Please contact SICK Service or a certified partner.

9 Troubleshooting

9.1 Important Information

Requirements on the maintenance personnel

- The technician must be familiar with the exhaust gas technology of the operator's plant (hazard by overpressure and toxic and hot flue gases) and be able to avoid hazards when working on gas ducts
- The technician must be familiar with handling compressed gas cylinders (span gases)
- The technician must be able to avoid hazards caused by noxious span gases
- The technician must be familiar with gas lines and their screw fittings (be able to ensure gas-tight connections)
- Only electricians are permitted to work on the electrical system or electrical sub-assemblies



NOTICE

Pay attention to voltage variants

Some spare parts are available in different voltage variants, 115 V or 230 V.

- ▶ Check spare parts for voltage dependency before fitting: [see "Power supply", page 105](#).

The power voltage of your system is shown on the type plates.



CAUTION

Hazard of severe damage to electronic subassemblies through electrostatic discharge (ESD)

When touching electronic subassemblies, there is a hazard of severe damage to the subassembly by electric potential equalization.

- ▶ Make sure you have the same electric potential as the subassembly (e.g. by grounding) before touching the subassembly.



CAUTION

Risk of chemical burns by acid gas

- ▶ Acid condensate can escape when working on the sample gas lines and the associated subassemblies
- ▶ Take appropriate protective measures for work (for example, by wearing a safety mask, protective gloves and acid resistant clothes)
- ▶ In case of contact with the eyes, rinse immediately with clear water and consult a doctor



CAUTION

Risk of contamination of analyzer

The gas sampling system and analyzer are flushed with instrument air when the system is not in measuring operation.

The analyzer can be contaminated when instrument air is switched off.

- ▶ Take the gas sampling system out of the exhaust duct when instrument air is not available for a longer period of time ([see "Replace gas sampling system", page 70](#))

Observe the following:

- ▶ After working on the gas path: Perform a leak tightness check: see "Performing a leak tightness check", page 66
- ▶ After exchanging subassemblies: Switch the system on according to the switch-on procedure: see "Switching on", page 19
- ▶ After exchanging a span gas cylinder: Check the compliance with the span gas concentration set in the menu: see "Span gas concentrations", page 27

**NOTE**

Consumable parts, wearing parts and spare parts: see "Consumable parts, wearing parts and spare parts", page 119

9.1.1 Information on span gases

**NOTICE**

Before working on span gas cylinders or span gas lines: Relieve the span gas pressure.

- ▶ Shut off the span gas cylinder.
- ▶ Open the span gas valve: Menu: **Adjustment/span gas**.
- ▶ Wait for about 1 minute until the pressure in the lines has been relieved.
- ▶ Close the span gas valve: Menu: **Adjustment/span gas**.

9.1.2 Tube screw fittings

Clamping ring screw connection

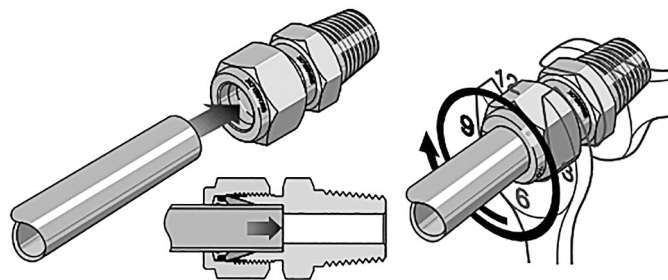

Figure 68: Clamping ring screw connection

- ▶ Push the tube up to the stop in the tube screw fitting.
Turn the cap nut finger-tight.
- ▶ During initial assembly: Hold the fitting bolt steady and tighten the cap nut with 1 1/4 revolutions.
- ▶ During refitting: Tighten the cap nut to the previous position (the resistance increases noticeably) and then slightly tighten.

Push-in fitting (pneumatic)

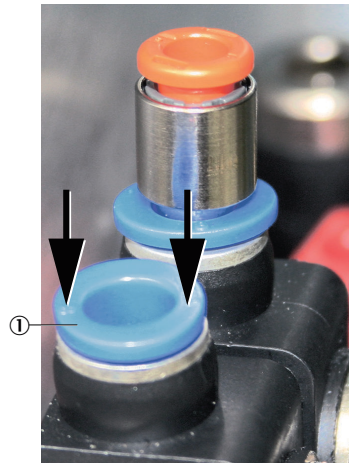

Figure 69: Push-in fitting with retaining ring

① Retaining ring

- ▶ Connecting the tube: Push tube in.
- ▶ Disconnecting the tube: Press the retaining ring in and pull the tube out.

It is easier to press the retaining ring in using the pressure tool provided.

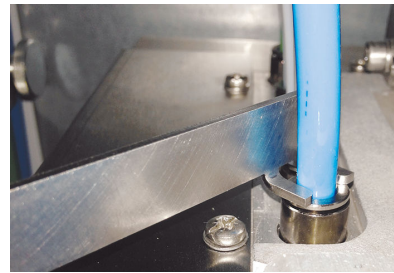

Figure 70: Pressure tool usage

Pressure tool

9.2 Measured values erroneous

Possible cause	Information
Device does not measure the sample gas	Check sample gas path and all valves (e.g. switch from span to sample gas)
Sample gas path leaky/clogged	Check installations: Leak tightness, corrosion, blockages
Device not adjusted correctly	Perform an adjustment (see "Adjustment", page 35). Check span gas beforehand (nominal value, service life, flow rate, configuration in menu (see "Span gas concentrations", page 27)
Check ambient conditions	<ul style="list-style-type: none"> • Check temperature, humidity, vibrations • Check instrument air quality



NOTE

If a message is shown on the display: see "Error messages and possible causes", page 112

9.3 Replace gas sampling system

- ▶ Switch analyzer to "Stand-by": see "System maintenance", page 34
- ▶ Flush system for 10 minutes in this state
- ▶ Switch system off at the external power disconnection unit



CAUTION

Caution: Hot surfaces!

- ▶ Before working on the gas sampling system: Allow gas sampling system to cool down.

**WARNING**

Health risk through dangerous sample gas.

If dangerous sample gas is applied to the SFU: The operator is responsible for safe handling of sample gas.

- ▶ In addition to these Operating Instructions, observe all local laws, technical rules, and company-internal instructions valid at the site where the SFU is installed.
- ▶ Operate the SFU only in rooms with adequate installation OR install suitable gas monitoring equipment.
- ▶ Channel sample gas off safely.

**WARNING**

Risk of burns on hot surfaces.

The filter can reach high temperatures in operation.

- ▶ Wear suitable gloves as necessary.
- ▶ Provide a heat-resistant storage surface as necessary.

**WARNING**

Hazards by noxious substances.

Filter cartridges can contain noxious substance depending on the sample gas composition.

- ▶ Observe relevant safety regulations.
- ▶ Dispose of filter cartridges in an environmentally responsible manner.

When the gas sampling system needs to be removed:

- ▶ Switch external instrument air off

Assembling the gas sampling system is described in the MARSIC300 Technical Information.

- ▶ Switch system on again at the external power disconnection unit: [see "Switching on", page 19](#)
- ▶ When the system is ready for operation: Perform a leak tightness check: [see "Performing a leak tightness check", page 66](#)
- ▶ Reset operating hours counter (menu: Diagnosis/System param./Counter Op. Hrs./Filter cell)

9.4 Replacing the sample gas line

Removing the sample gas line

- ▶ Switch analyzer to "Stand-by": [see "System maintenance", page 34](#)
- ▶ Flush system for 10 minutes in this state
- ▶ Switch system off at the external power disconnection unit

**WARNING**

Hazard through sample gas pressure.

Smoke extractors can be subject to overpressure or underpressure.

- ▶ Observe the information provided by the plant operator.

**WARNING**

Risk of burns on hot surfaces.

Filter housing, flanges and sample gas line can be hot.

- ▶ Let surfaces cool down to body temperature before working on device parts or wear suitable protective gloves.
-

**WARNING**

Danger to life by electric voltage

- ▶ Only allow an authorized electrician to work on the electric system
-

**WARNING**

Hot surfaces

Risk of burns when touching the surfaces

- ▶ Switch analyzer off and allow to cool down

or

- ▶ Wear suitable protective clothes, for example, heat-resistant gloves.
-

Removing

1. Unscrew the sample gas line on the gas sampling system: See the provided “Gas Sampling System SFU Operating Instructions”
2. Unscrew the sample gas line in the analyzer: Described in the MARSIC300 Technical Information.
3. Disconnect electric connections in analyzer.
4. Pull sample gas line out of analyzer.

Laying the sample gas line

Described in the MARSIC300 Technical Information.

Fitting the sample gas line

5. Assembly on gas sampling system: See the provided “Gas Sampling System SFU Operating Instructions”
 6. Assembly on analyzer: Described in the MARSIC300 Technical Information.
- ▶ Switch system on again at the external power disconnection unit: [see "Switching on", page 19](#)
 - ▶ When the system is ready for operation: Perform a leak tightness check: [see "Performing a leak tightness check", page 66](#)

9.4.1 Swapping the temperature sensor Pt100 (heated sample gas line)



Figure 71: Pt100 line

- ① 2 x Pt100 connections (1 as reserve)

The heated sample gas line has 2 Pt100s.
One Pt100 serves as reserve.

Swap Pt100

1. Disconnect defective Pt100
2. Connect replacement Pt100

Terminal assignment: [see "Connections in analyzer", page 106](#)

9.5 Replacing the housing fan

- ▶ Switch analyzer to “Stand-by”: [see "System maintenance", page 34](#)
- ▶ Flush system for 10 minutes in this state
- ▶ Switch system off at the external power disconnection unit

Removing

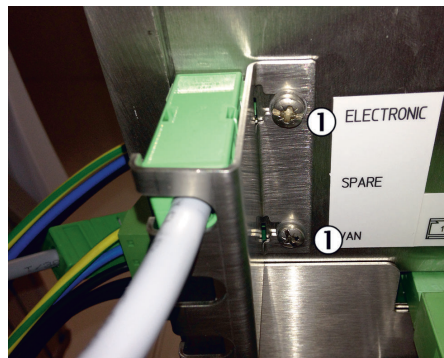

Figure 72: Safety plate

- ① 2 screws on safety plate on underside of electronics unit

1. On the underside of the electronics unit: Loosen 2 screws of safety plate and remove safety plate
2. Loosen screws of safety plate and remove safety plate

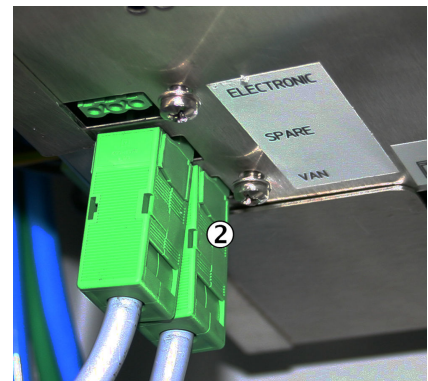

Figure 73: Housing fan plug

- ② Housing fan plug (Van)



Figure 74: Power supply cover
① Fan power supply cover



Figure 75: Fan power supply
② Fan power supply



WARNING

Only have work done on the electric system by a qualified electrician.

3. Remove red cover from connection terminals
4. Disconnect electric line by pressing on the connection terminals
5. Turn fan counter-clockwise and take off

Fitting

- ▶ Position fan and turn clockwise to latch
- ▶ Connect electric lines
 - 1 = L
 - PE
 - 2 = N
- ▶ Fit red cover

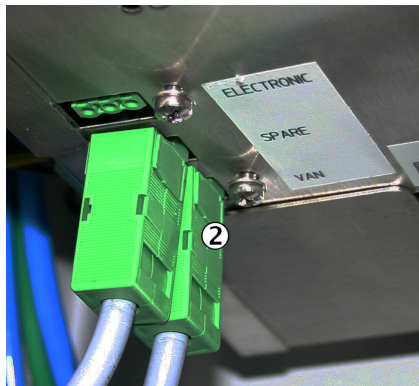

Figure 76: Housing fan plug
② Housing fan plug (Van)

- ▶ Reconnect plug on underside of analyzer
- ▶ Refit safety plate correctly and screw tight
- ▶ Switch system on again at the external power disconnection unit: [see "Switching on", page 19](#)

9.6 Replacing the O₂ sensor

- ▶ Switch analyzer to “Stand-by”: [see "System maintenance", page 34](#)
- ▶ Flush system for 10 minutes in this state
- ▶ Switch system off at the external power disconnection unit

Removing

1. Switch system off at the external power disconnection unit.

**CAUTION**

Caution: Hot surfaces!

- ▶ Before working on the cell: Allow cell to cool down.

2. Unscrew plug-in connector of the O₂ sensor from the electronics: [see "Connections in analyzer", page 106](#)
3. Open cell cover (loosen 4 screws on the side)

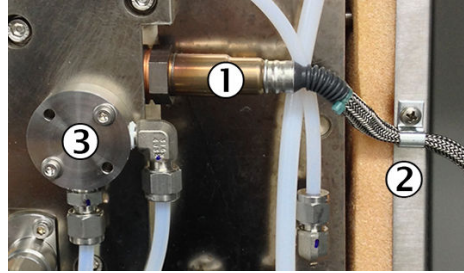

Figure 77: O₂ sensor

- ① O₂ sensor
- ② O₂ sensor cable fixing
- ③ Distributor unit

4. Loosen fixing of O₂ sensor line
5. Unscrew distributor unit
6. Screw O₂ sensor out (key width 22-0.3 mm)
Important: Observe correct key width otherwise the hexagon of the O₂ sensor will be damaged

Fitting

1. Fit new copper seal (delivered with the new O₂ sensor) to thread of the O₂ sensor
 2. Screw O₂ sensor in
 3. Fix the O₂ sensor line again
 4. Screw distributor unit on again (a new O-ring is delivered with the new O₂ sensor)
 5. Refit cell cover and screw tight
 6. Screw the O₂ sensor plug-in connector tight to the electronics again
- ▶ Switch system on again at the external power disconnection unit: [see "Switching on", page 19](#)
 - ▶ When the system is ready for operation: Perform a leak tightness check: [see "Performing a leak tightness check", page 66](#)
 - ▶ Perform an O₂ sensor adjustment: [see "With span gas", page 25](#)

9.7 Replacing the span gas valve

- ▶ Switch analyzer to "Stand-by": [see "System maintenance", page 34](#)
- ▶ Flush system for 10 minutes in this state
- ▶ Switch system off at the external power disconnection unit



WARNING

Hazard when pressure is too high
Hoses can burst when the pressure is too high.

- ▶ Observe the maximum pressures of the gases provided by the operator: [see "Supply gases", page 110](#).

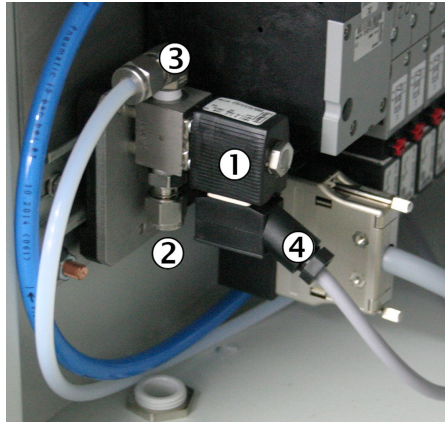

Figure 78: Span gas valve

- ① Span gas valve
- ② Span gas inlet
- ③ Span gas to cell
- ④ Power supply



NOTICE

Before starting work:

- ▶ Close the span gas cylinder.
- ▶ Relieve remaining pressure from tube. To do this, open a line screw fitting slowly for a short time and then close it again.

Removing

1. Unscrew span gas feed line on span gas valve.
2. Unscrew line to cell on span gas valve.
3. Push span gas valve upwards and unlatch from top hat rail.
4. Unscrew power supply on span gas valve.

Fitting

1. Screw power supply on span gas valve.
 2. Latch span gas valve on top hat rail.
 3. Screw line to cell on span gas valve.
 4. Screw gas feed line on span gas valve.
- ▶ Switch system on again at the external power disconnection unit: [see "Switching on", page 19](#)
 - ▶ When the system is ready for operation: Perform a leak tightness check: [see "Performing a leak tightness check", page 66](#)
 - ▶ Reset operating hours counter (menu: Diagnosis/System param./Counter Op. Hrs./Filter cell)

9.8 Replacing the needle valve

9.8.1 MARSIC300 with on sampling point

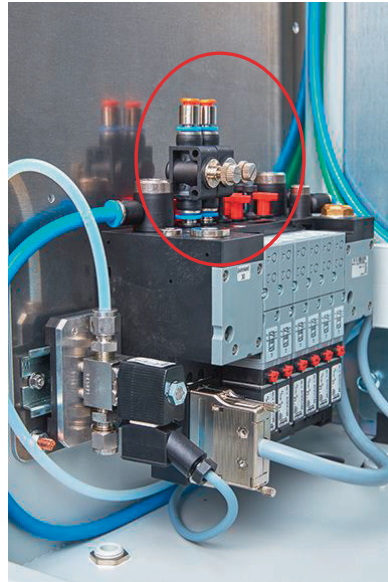

Figure 79: Needle valve on valve block

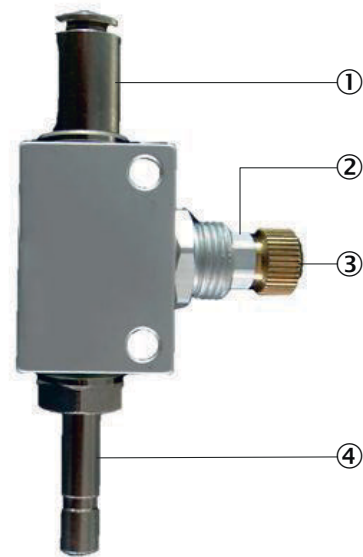

Figure 80: Needle valve

- ① Insert white Teflon tube
- ② Knurled lock nut (hexagonal ring)
- ③ Brass color screw
- ④ Fit on valve block

1. Close the needle valve to be replaced off completely before fitting. To do this, open the knurled lock nut (hexagonal ring) completely (counter-clockwise) and close the brass color screw completely (clockwise).
2. Disconnect the white Teflon tube from the defective needle valve, to do this, press the orange ring down and pull the tube off. Instrument air may flow out of the needle valve.
3. Take the defective needle valve off the valve block (to do this, possibly use the tool for fitting/removing tubes). Instrument air may flow out of the needle valve.
4. Fit new needle valve on valve block.
5. Connect the white Teflon tube on the new needle valve.
6. Switch the MARSIC300 to standby:
 - Zero gas solenoid valve opens automatically
 - ▶ Check flow rate on display
 - Flow rate should be 0 l/h
7. Open the new needle valve until the flow rate on the display is approx. 300 l/h. Lock the needle valve screw position with the knurled nut.
8. Switch MARSIC300 to "Measure".

9.8.2 MARSIC300 with two sampling points

Exchanging one defective needle valve

1. Close the needle valve to be replaced off completely before fitting. To do this, open the knurled lock nut (hexagonal ring) completely (counter-clockwise) and close the brass color screw completely (clockwise).
2. Disconnect the white Teflon tube from the defective needle valve, to do this, press the orange ring down and pull the tube off. Instrument air may flow out of the needle valve.

3. Take the defective needle valve off the valve block (to do this, possibly use the tool for fitting/removing tubes). Instrument air may flow out of the needle valve.
4. Fit new needle valve on valve block.
5. Connect the white Teflon tube on the new needle valve.
6. Switch the MARSIC300 to standby:
 - Zero gas solenoid valve opens automatically
 - ▶ Check flow rate on display
 - Flow rate on the display should be approx. 150 l/h, if not, correct the flow rate with the existing needle valve
7. Open the new needle valve until the flow rate on the display is approx. 300 l/h. Lock the needle valve screw position with the knurled nut.
8. Switch MARSIC300 to "Measure".

Exchanging two defective needle valves

1. Close off one of the needle valves to be replaced completely before fitting. To do this, open the knurled lock nut (hexagonal ring) completely (counter-clockwise) and close the brass color screw completely (clockwise).
2. Disconnect the white Teflon tube from this needle valve, to do this, press the orange ring down and pull the tube off. Instrument air may flow out of the needle valve.
3. Take the defective needle valve off the valve block. To do this, possibly use the tool for fitting/removing tubes. Instrument air may flow out of the valve block.
4. Fit new needle valve on valve block.
5. Connect the white Teflon tube on the new needle valve.
6. Repeat steps 1 - 5 for second needle valve.
7. Switch the MARSIC300 to standby:
 - Zero gas solenoid valve opens automatically
 - ▶ Check flow rate on display
 - Flow rate should be approx. 0 l/h
8. Open one of the new needle valves until the flow rate on the display is approx. 150 l/h.
9. Open the second needle valve until the flow rate on the display is approx. 300 l/h.
10. Lock both needle valve screw positions with the knurled nut.
11. Switch MARSIC300 to "Measure".

9.9 Replacing the cell

- ▶ Switch analyzer to "Stand-by": [see "System maintenance", page 34](#)
- ▶ Flush system for 10 minutes in this state
- ▶ Switch system off at the external power disconnection unit



WARNING

Hot surfaces

Risk of burns when touching the surfaces

- ▶ Allow cell to cool down
-

Removing

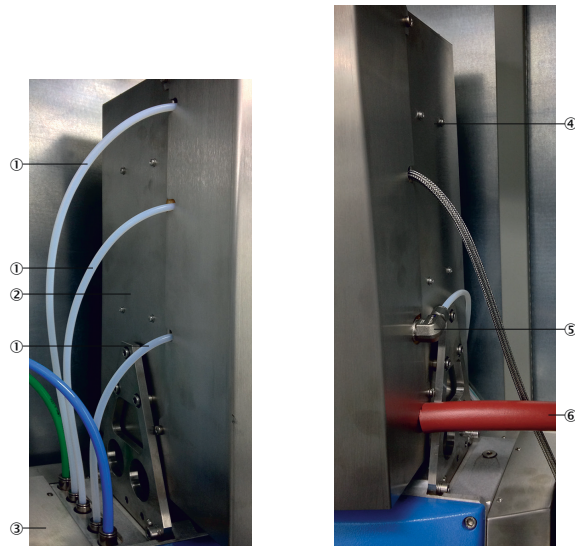

Figure 81: Cell

- ① Tubes to cell
- ② Cell
- ③ Pressure control module
- ④ O₂ sensor line
- ⑤ Span gas inlet
- ⑥ Sample gas outlet

1. Mark the 3 tube connections on the left side of the cell
2. Disconnect the 3 marked tube connections from the pressure control module. To do this, press the retaining rings of the tube screw fittings down
3. Unscrew plug-in connector of the O₂ sensor from the electronics: [see "Connections in analyzer", page 106](#)
4. Unscrew heated sample gas line (for two sampling points: Both sample gas lines)
5. Unscrew span gas connection on cell
6. Unscrew plug-in connector of cell heating at the bottom on the electronics.
7. Open cell cover (loosen 4 screws on the side)

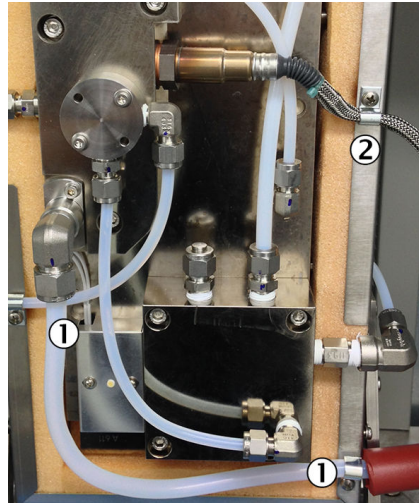

Figure 82: Cell, inside

- ① Sample gas outlet line
- ② O₂ sensor line

8. Unscrew sample gas outlet on sample gas outlet
9. Loosen fixing of sample gas outlet line
10. Loosen fixing of O₂ sensor line
11. Unscrew 4 screws of cell holder (2 screws each left and right)

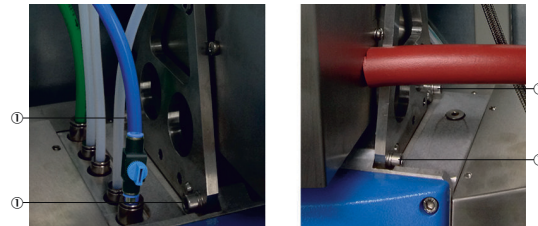

Figure 83: Cell holder

- ① Cell holder screws

12. Lift cell upwards and take it out of the wall housing

Fitting

1. Insert cell in wall housing and screw tight
Cell must sit flush at the bottom on the bolts provided
If the cell does not sit flush on the bolts:
 - o The cell has a guide at the top end
 - o Loosen this guide temporarily. This adapts the cell seat and guide to each other

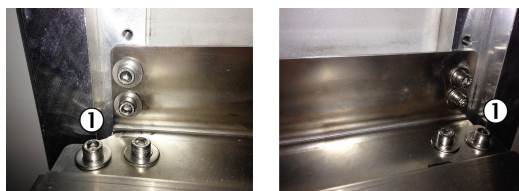

Figure 84: Guide screws

- ① Guide screws

- o After fitting the cell holder screws: Fix the guide again

2. Fix the O₂ sensor line again
 3. Reconnect and fix the sample gas outlet line
 4. Refit cell cover and screw tight
 5. Screw plug-in connector of cell heating on at the bottom on the electronics
 6. Screw gas connection on cell
 7. Screw heated sample gas line on (for two sampling points: Both sample gas lines)
 8. Screw the O₂ sensor plug-in connector tight to the electronics again
 9. Reconnect the 3 marked tube connections according to the marking
- ▶ Switch system on again at the external power disconnection unit: [see "Switching on", page 19](#)
 - ▶ When the system is ready for operation: Perform a leak tightness check: [see "Performing a leak tightness check", page 66](#)
 - ▶ Perform zero point adjustment: See menu "Adjustment/Zero point"
 - ▶ Perform adjustment with zero gas: See menu "Adjustment/Span gas"
 - ▶ Perform O₂ sensor adjustment: Menu "Adjustment/Span gas/Adjust O2"

**NOTICE**

After changing the cell, check the H₂O correction at the next possible point of time: [see "Performing an H₂O check", page 67.](#)

9.10 Replacing the pressure reducer unit

- ▶ Switch analyzer to "Stand-by": [see "System maintenance", page 34](#)

**WARNING**

Hazard when pressure is too high
Hoses can burst when the pressure is too high.

- ▶ Observe the maximum pressures of the gases provided by the operator: [see "Supply gases", page 110.](#)

**NOTICE**

Before starting work:

- ▶ Hosing is device-specific: Note the existing connections
- ▶ Note the pressures set

Removing

1. When the pressure reducer unit is still functioning: Flush system for 10 minutes in this state
2. Close off operator's instrument air supply
3. Disconnect tubes on pressure reducer unit

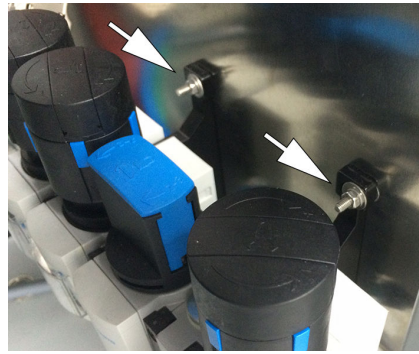

2 top nuts on pressure reducer unit

Figure 85: Pressure reducer unit

4. Unscrew 4 fastening nuts from housing side and remove the pressure reducer unit.

Fitting

1. Fit the pressure reducer unit
2. Fit tubes as before
3. Ensure all controllers for working pressures are relieved (turn controllers counter-clockwise to stop)
4. Open operator's instrument air supply again
5. Reset the respective working pressures on the pressure gauges with the controllers
6. Switch standby off again

9.10.1 Setting the pressure reducer module

The external air supply is fitted on the pressure reducer module.

- ▶ Set the controllers to the pressures shown in the Figure.

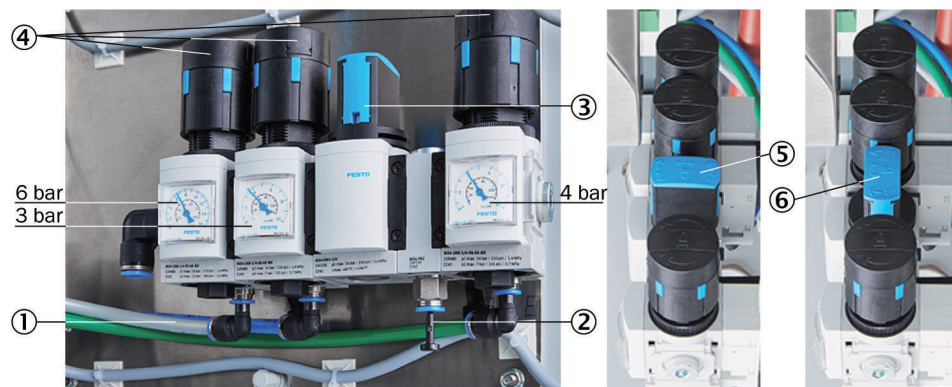

Figure 86: Pressure reducer unit

- ① Instrument air inlet with zero gas quality
- ② Instrument air inlet for induction air ejector only
- ③ Manual valve for instrument air selection
- ④ 3 pressure reducers (adjustable)
- ⑤ Manual valve - closed position
- ⑥ Manual valve - open position

The instrument air is used as both induction air for the ejector (cell) and zero/control air.

There are two possibilities of connecting instrument air:

- ▶ One (1) common instrument air supply for ejector air and zero/control air (inlet 1)
- ▶ Separate instrument air supply for:
 - Ejector air (inlet 2)
 - and zero/control air (inlet 1)

Instrument air quality

The quality requirement for instrument air used exclusively as ejector air is lower than for usage as zero/control air (zero gas quality) (see "Supply gases", page 110).

- ▶ When connected just as instrument air supply with zero gas quality to be used as common air for both ejector air and zero/control air (on inlet 1):
 - ▶ Set manual valve to position "open".
- ▶ When connected as (1) instrument air supply for the ejector (on inlet 2) and as instrument air supply with zero gas quality (on inlet 1):
 - ▶ Set manual valve to position "closed".

9.11 Replacing the pressure control module

- ▶ Switch analyzer to "Stand-by": see "System maintenance", page 34
- ▶ Flush system for 10 minutes in this state
- ▶ Switch system off at the external power disconnection unit

Removing

1. Close off operator's instrument air supply

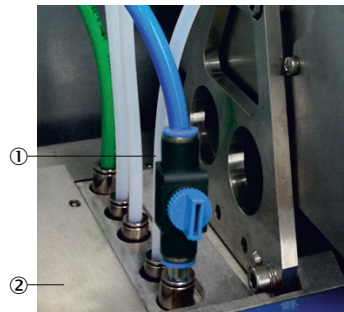

Figure 87: Pressure control module tubes

- ① Pressure control module tubes
- ② Pressure control module



Figure 88: Electronic housing

- ③ 11 screws

2. Mark all tube connections to pressure control module.
3. Disconnect marked tube connections from the pressure control module; To do this, press the retaining rings of the tube screw fittings down (If necessary, use the pressure tool provided with the device to press the retaining rings down)
4. Unscrew fastening screws of the electronic housing (9 screws)
 - 7 screws on the front side
 - 1 screw each left and right
5. Loosen side fastening screws (do not unscrew) (2 x 3 screws)

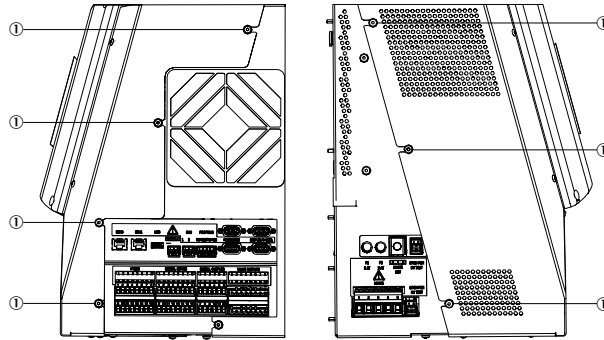

Figure 89: Fastening screws

- ① 1 x 3, 1 x 4 screws

6. Take housing cover off forwards

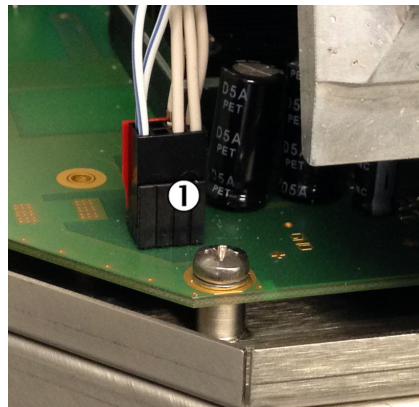

Figure 90: Pressure control module line

- ① Pressure control module line

7. Disconnect line to pressure control module

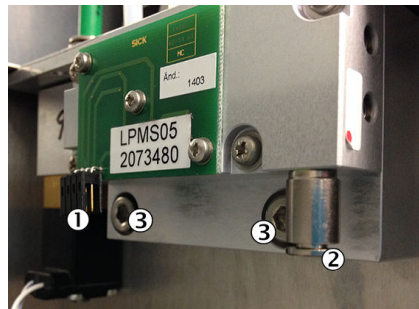

Figure 91: Pressure control module

- ① Electrical connection line
- ② Purge air tube
- ③ 2 screws

- 8. Disconnect electrical connection line
- 9. Disconnect purge air tube. To do this, push the retaining ring down
- 10. Unscrew pressure control module (2 screws)

Fitting

1. Screw new pressure control module tight
 2. Reconnect purge air tube
 3. Reconnect electrical connection line
 4. Refit housing cover and screw tight with all screws
Here, screw the front side screws tight first
 5. Connect tubes to pressure control module
 6. Turn instrument air supply on again
 7. Switch the system on again: [see "Switching on", page 19.](#)
 8. Perform pressure sensor adjustment: [see "System maintenance", page 34](#)
 9. Reconnect all tubes on pressure control module
 10. Turn instrument air supply on again
- ▶ Switch system on again at the external power disconnection unit: [see "Switching on", page 19](#)
 - ▶ Perform pressure sensor adjustment: [see "System maintenance", page 34](#)

9.12 Replacing the valve block

- ▶ Switch analyzer to "Stand-by": [see "System maintenance", page 34](#)
- ▶ Flush system for 10 minutes in this state
- ▶ Switch system off at the external power disconnection unit

Removing

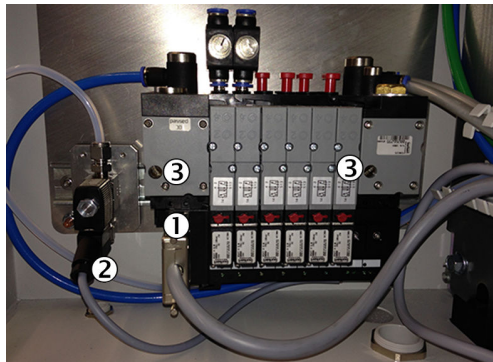

Figure 92: Valve block

- ① Multipole plug
 - ② Span gas valve power supply
 - ③ 2 screws
1. Note position of tubes leading to valve block
 2. Close off operator's instrument air supply
 3. Unscrew and remove multipole plug
 4. Take span gas valve out of top hat rail (to do this, push span gas valve upwards and tilt forwards)
 5. Unscrew and remove power supply plug on span gas valve
 6. Loosen 2 screws 2-3 turns with a screwdriver
 7. Take valve block off top hat rail
 8. Disconnect tubes. To do this, push the retaining ring down
 9. Take valve block out

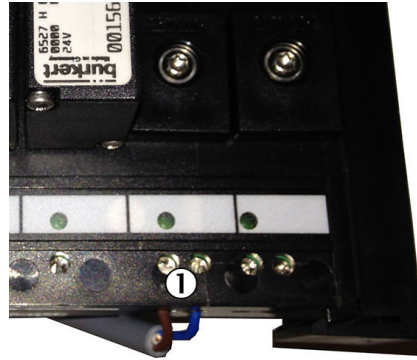

Figure 93: Line on valve block

- ① Electric line



WARNING

Only have work done on the electric system by a qualified electrician.

10. Unscrew electric line.

Fitting

1. Screw electric line on
 2. Latch span gas valve on top hat rail
 3. Connect tubes according to markings made
 4. Latch valve block on top hat rail
 5. Screw 2 screws tight
 6. Connect power supply on span gas valve and screw on.
 7. Connect multipole plug and screw tight by hand
 8. Turn instrument air supply on again
- ▶ Switch system on again at the external power disconnection unit: [see "Switching on", page 19](#)
 - ▶ When the system is ready for operation: Perform a leak tightness check: [see "Performing a leak tightness check", page 66](#)
 - ▶ Reset operating hours counter (menu: Diagnosis/System param./Counter Op. Hrs./Filter cell)

9.12.1 Connecting the valve block



WARNING

Hazard when pressure is too high
Hoses can burst when the pressure is too high.

- ▶ Observe the maximum pressures of the gases provided by the operator: [see "Supply gases", page 110](#).

The following are located on the valve block:

- Gas connections of the gas sampling unit hose bundle line
- Span gas inlet (front, below)

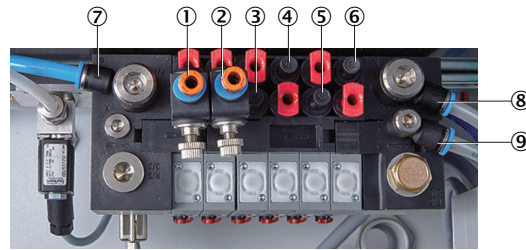

Figure 94: Valve block connections

- ① Outlet: Zero gas measuring point 1
- ② Outlet: Zero gas measuring point 2 (option)
- ③ Outlet: Control air measuring point 1
- ④ Outlet: Backflush air measuring point 1
- ⑤ Outlet: Control air measuring point 2 (option)
- ⑥ Outlet: Backflush air measuring point 2 (option)
- ⑦ Inlet: Zero gas
- ⑧ Inlet: Control/backflush air
- ⑨ Inlet: Auxiliary control air
- Red plug = dummy plug

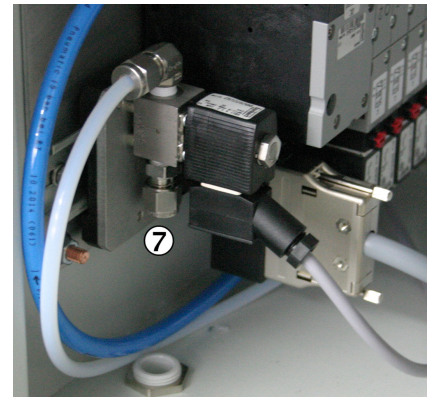

Figure 95: Span gas inlet

- ⑦ Span gas inlet

If necessary, use the pressure tool provided with the device to press the retaining rings of the tube connections down.

9.13 Replacing the display

- ▶ Switch analyzer to “Stand-by”: [see "System maintenance", page 34](#)
- ▶ Flush system for 10 minutes in this state
- ▶ Switch system off at the external power disconnection unit

Removing

1. Unscrew display cover (4 screws) and take display off

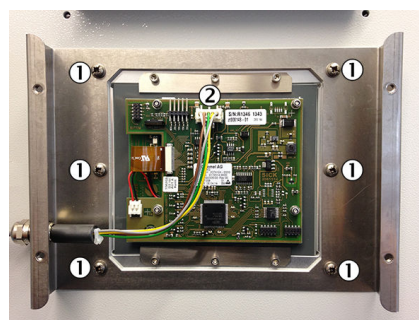

Figure 96: Display fastening

- ① Display screws
 - ② Plug
2. Disconnect plug from circuit board
 3. Unscrew display (6 screws)
This loosens both the display and metal frame
Be careful not to let the display or metal frame drop down



CAUTION

Be careful not to let the display or metal frame drop down

Fitting

1. Insert metal frame and display (plug at top) and screw tight
 2. Reconnect electric connections to circuit board
 3. Fit cover and screw tight
- ▶ Switch system on again at the external power disconnection unit: [see "Switching on", page 19](#)

9.14 Replacing the electronics unit

When possible: Backup parameters on internal SD card: Menu Maintenance/Backup parameters

- ▶ Switch analyzer to "Stand-by": [see "System maintenance", page 34](#)
 - ▶ Flush system for 10 minutes in this state
 - ▶ Switch system off at the external power disconnection unit
-



WARNING

Hot surfaces

Risk of burns when touching the surfaces

- ▶ Allow electronics unit to cool down
-

Removing



Figure 97: Fastening screws

- ③ 11 screws

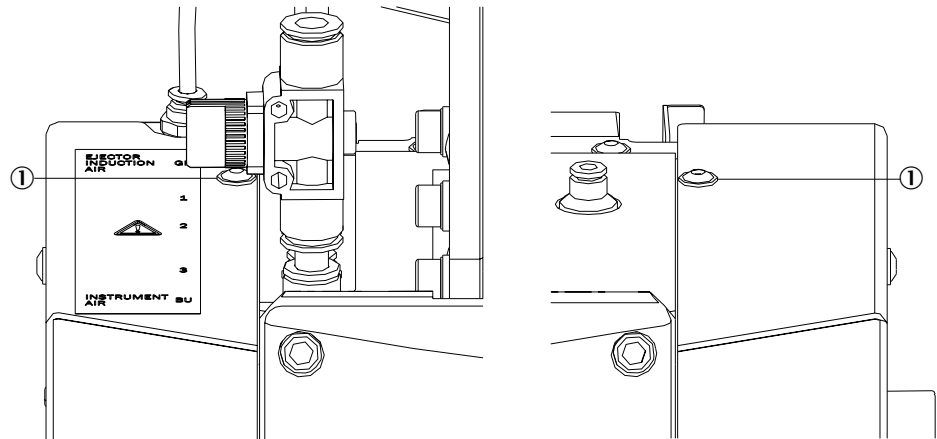

Figure 98: Top fastening screws

① Fastening screws

1. Unscrew fastening screws of the electronic housing (9 screws)
 - 7 screws on the front side
 - 1 screw each left and right
2. Loosen side fastening screws (do not screw out) ((1x 3 screws (right), 1x 4 screws, left))

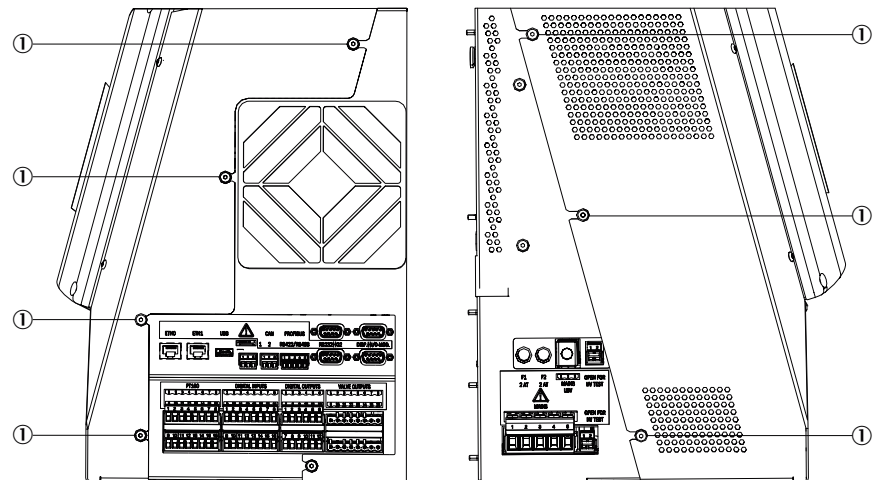

Figure 99: Side fastening screws

① 1 x 3, 1 x 4 screws

3. Take housing cover off forwards

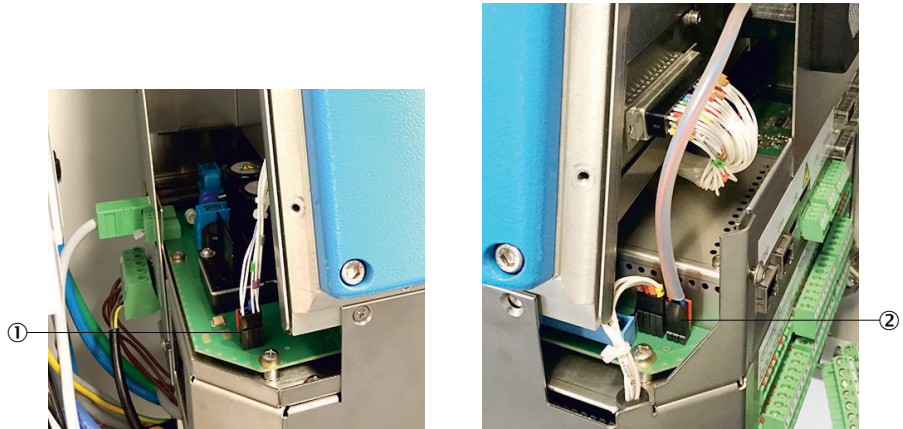

Figure 100: Pressure control module and fan lines

- ① Pressure control module line
- ② Fan line

4. Disconnect line to pressure control module
5. Disconnect line to fan

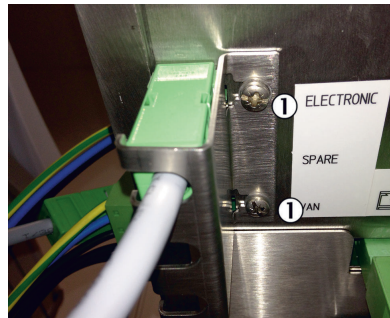

Figure 101: Safety plate

- ① 2 screws on safety plate on underside of electronics unit

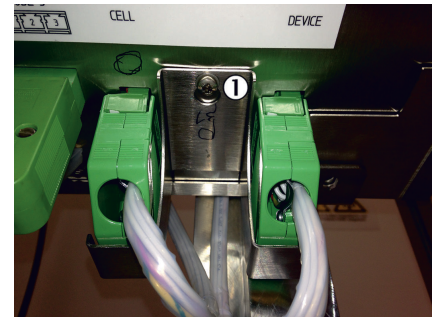

Figure 102: Safety plate

- ① Screw

6. Loosen screws of 2 safety plates (underside of electronics unit) and remove safety plates.

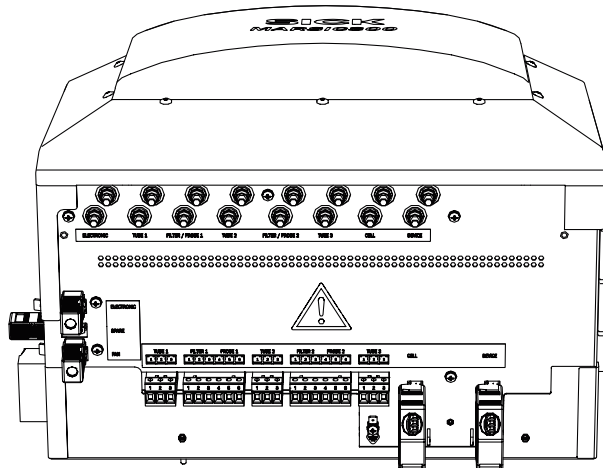

Figure 103: Connections, underside

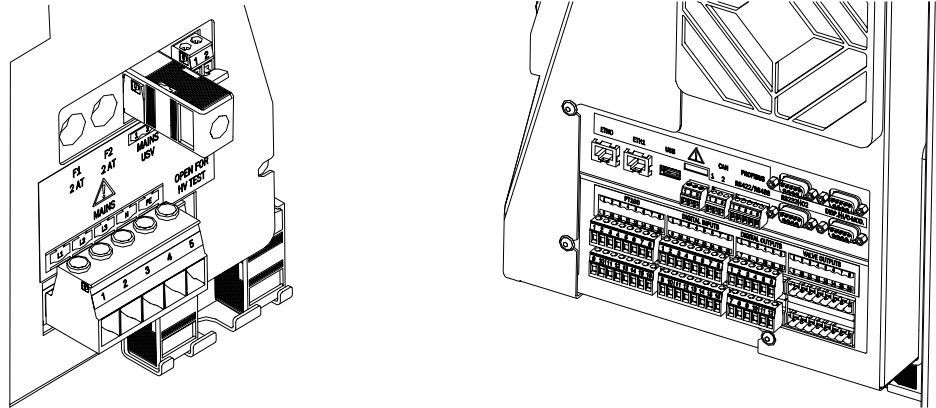

Figure 104: Connections, left/right sides

7. Disconnect all plug-in connectors: (see "Connections in analyzer", page 106)



NOTE

The plugs are all coded and can only be reconnected to the correct socket
Exception: 2 power supply plugs are identical. Swapping is not critical

- All plugs on the underside:
 - Power supply, electronics
 - Power supply, housing fan
 - Power supply, measuring cell
 - Power supply, optic head (device)
 - Power supply, heating tubes
 - Power supply, sampling probe
- All plugs on the left side:
 - Power supply, system
 - Power supply, electronics
 - HF test bridges
- All plugs on the right side:
 - I/O
 - Pt100
 - Connecting plug, optic head

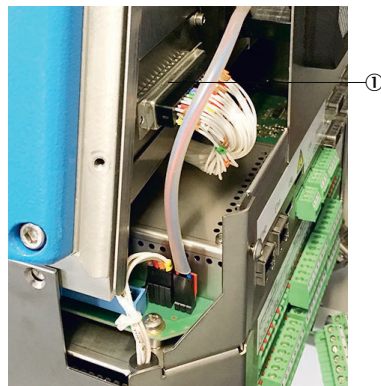

Figure 105: 50-pole plug

- ① 50-pole plug

8. Unscrew and remove 50-pole plug



Figure 106: Electronics housing screws

- ① 3 screws



NOTICE

Protect the electronics unit from dropping down when loosening the screws

9. Unscrew electronics unit (3 screws)
10. Pull electronics unit out forwards
11. Press SD card (on right side) in with a small screwdriver and pull out with a pair of tweezers (see "Connections in analyzer", page 106)
12. Adapt the power system:
 - ▶ Unscrew top electronic board LPMS01: 2 screws on metal part at bottom (not on the board), 2 screws on metal part at the rear
 - ▶ Take top electronic board off
 - ▶ Disconnect ribbon cable and multipole line on bottom circuit board
 - ▶ On bottom board (LPMS02): Note or photograph plugged positions of lines (the current positions are also described in the system documentation provided with your system)

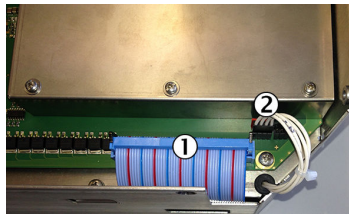

Figure 107: Ribbon cable

- ① Ribbon cable
- ② Multipole line

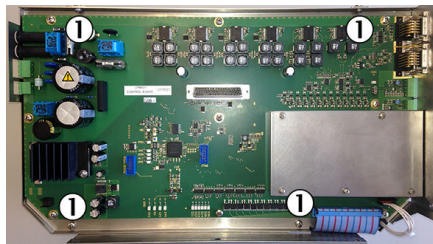

Figure 108: Electronics circuit board

- ① 4 screws

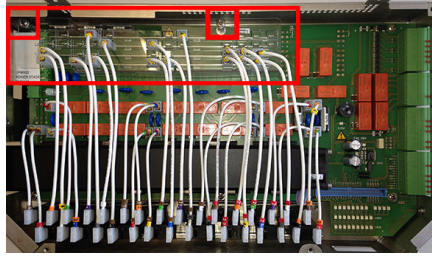

Figure 109: Connection layout

- ▶ Disconnect lines on the board to be replaced from the power rails (area marked in Figure)
You can pull the lines carefully. Do not use tools.
- ▶ Unscrew plastic template on the electronic board to be replaced (2 screws) and fit it on the new electronic board. (To do this, remove the dummy template first).
- ▶ Connect lines in the new electronic board in the template according to the noted positions (or as described in the system documentation of your system).
Make sure the plugs have complete contact
- ▶ Reconnect ribbon cable as well as multipole line. Refit electronic board LPMS01 and screw tight.

Fitting

1. Insert old SD card in new electronics unit
2. Push electronics unit in the analyzer and screw tight with 3 screws
3. Connect 50-pole plug
4. Reconnect all plugs (see "Connections in analyzer", page 106)

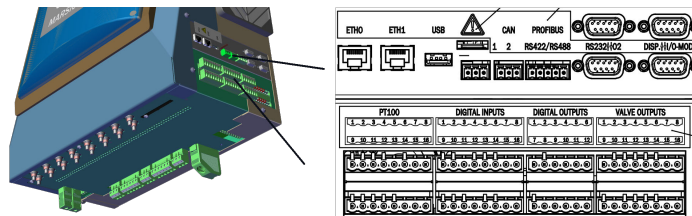

Figure 110: Connection overview, right side



NOTE

The plugs are all coded and can only be reconnected to the correct socket.
Exception: 2 power supply plugs are identical. Swapping is not critical.

5. Refit both safety plates correctly and screw tight
 6. Reconnect fan line
 7. Reconnect pressure control module line
 8. Refit housing cover and screw tight with all screws
Here, screw the front side screws tight first
- ▶ Switch system on again at the external power disconnection unit: see "Switching on", page 19

9.15 Replace Analyzer module

Backup parameters on internal SD card: Menu **Maintenance/Save parameters**.

- ▶ Switch analyzer to “Stand-by”: see "System maintenance", page 34
- ▶ Flush system for 10 minutes in this state
- ▶ Switch system off at the external power disconnection unit

Removing



CAUTION

Caution: Hot surfaces!

- ▶ Before working on the cell: Allow cell to cool down

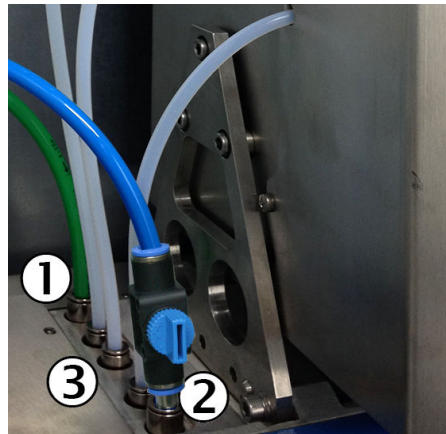

Figure 111: Tubes

- ① Green tube: Ejector induction air
- ② Blue tube: Pressure control air
- ③ Pressure control module

1. Mark position of 2 tubes (green and blue) to be disconnected on the left side of the cell
2. Close ball valve of blue tube
3. Note pressure setting of the green tube on the pressure reducer and set to 0 bar (front connection)
4. Disconnect the 2 marked tube connections from the pressure control module; To do this, press the retaining rings of the tube screw fittings down (If necessary, use the pressure tool provided with the device to press the retaining rings down)

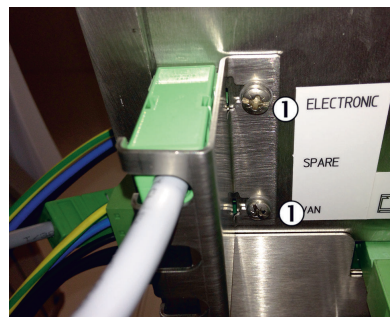

Figure 112: Safety plate

- ① 2 screws on safety plate on underside of electronics unit

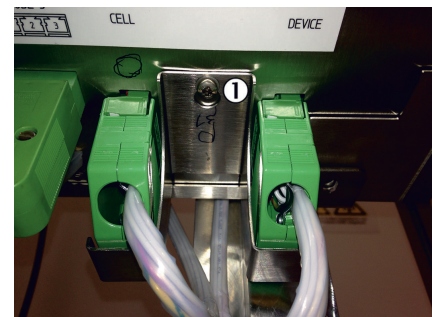

Figure 113: Safety plate

- ① Screw

5. Loosen screws of 2 safety plates (underside of electronics unit) and remove safety plates

6. Disconnect all plugs left, right and below from electronics unit (see "Connections in analyzer", page 106)
7. Open cell cover (loosen 4 screws on the side)

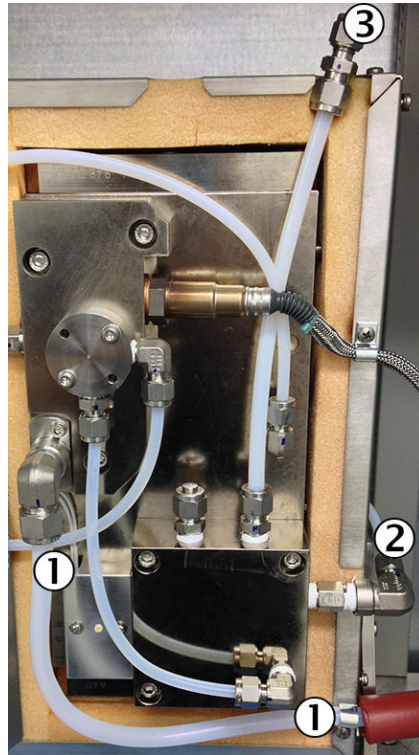

Figure 114: Cell, inside

- ① Sample gas outlet line
- ② Span gas connection
- ③ Sample gas inlet

8. Unscrew sample gas outlet on sample gas outlet (bracket piece)
9. Loosen fixing of sample gas outlet line
10. Unscrew test gas line on span gas connection on bracket piece
11. Unscrew sample gas inlet
12. Close cell cover again



Figure 115: Cover

- ① Screws on blue cover

13. Loosen 4 screws on blue cover
14. Take blue cover off

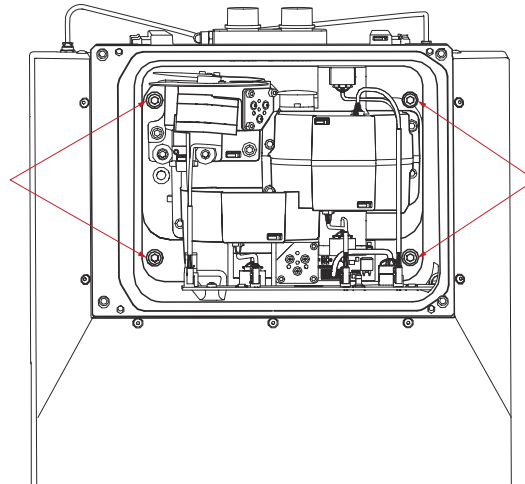

Figure 116: Screws inside

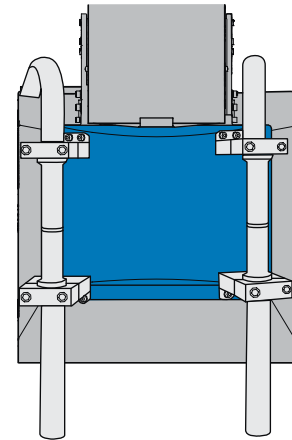

Figure 117: Transport cover

15. Unscrew 4 screws of Analyzer module fastening and take the 4 screws out
16. Unscrew transport cover (blue cover with 2 transport handles) from new Analyzer module
17. Screw transport cover tight on Analyzer module to be removed (4 screws)
 - o The top handles can be adapted to the best personal position before assembly (two persons removing/fitting Analyzer module).
 - o The bottom handles serve as feet as shown to put the removed Analyzer module down
18. Make sure no lines are still fixed or can be clamped



WARNING

Health risk when lifting a heavy load
 The Analyzer module is heavy: Approx. 50 kg

- ▶ Use 2 persons to lift the Analyzer module out of the housing

19. Lift Analyzer module carefully on the transport cover out of the housing and put down safely

Adapting the power system

If the power system of the new Analyzer module differs from the old Analyzer module (see provided system documentation):

- ▶ Adapt the power system of the new Analyzer module to that of the old Analyzer module: [see "Replacing the electronics unit", page 88](#)

Fitting

1. Unscrew transport cover from removed Analyzer module and screw it on the new Analyzer module
2. Slide Analyzer module carefully into the housing
3. Unscrew transport cover
4. Screw 4 screws of Analyzer module fastening tight
5. Screw blue cover on new Analyzer module
6. Reconnect all lines to the cell (as described under "Removing" above) and close the cell
7. Turn external instrument air supply on again
8. Screw transport cover on removed Analyzer module
9. Reconnect all electrical lines on the electronics unit ([see "Connections in analyzer", page 106](#))

10. Refit 2 safety plates correctly
11. Reconnect green tube (ejector induction air) and blue tube (pressure control air)
 - ▶ Switch system on again at the external power disconnection unit: [see "Switching on", page 19](#)
 - ▶ When the system is ready for operation: Perform a leak tightness check: [see "Performing a leak tightness check", page 66](#)
 - ▶ Perform zero point adjustment for all components (optional also for O₂): Menu Adjustment/Zero point

Possible error causes

Table 10: Error causes

Errors	Possible cause
No O ₂ sensor signal	O2 sensor and display plugs swapped
Display does not display anything	O2 sensor and display plugs swapped
No Ethernet connection	ETH0 and ETH1 plugs swapped

10 Decommissioning

10.1 Switch-off states

Stand-by

Switch system to stand-by to put it out of operation for some time: See menu Maintenance/Maint sys.

- The maintenance signal on the analyzer switches to “on” and the yellow LED on the display goes on
- Measured values are updated further
- The ejector pump switches off
- The heaters remain switched on
- The probe tube of the gas sampling system is flushed with instrument air

Switch-off

Switch system off to perform maintenance work for example

- ▶ Switch analyzer to “Stand-by”: [see "System maintenance", page 34](#)
- ▶ Flush system for 10 minutes in this state
- ▶ Switch system off at the external power disconnection unit



NOTICE

Do not switch instrument air off.

The gas sampling system is still flushed with instrument air.

Thermostatic control of the gas sampling system is switched off.

Shutdown

- ▶ Switch system off: See above
- ▶ Make sure the gas sampling system can not become soiled (for example, by pulling the probe tube)
- ▶ Switch external instrument air off
- ▶ Close off gas inlets and outlets gas-tight



NOTICE

Replace drying agent yearly even when shutdown: [see "Replacing the drying agent", page 59](#)

10.2 Protective measures for long-term storage

- When gas lines were unscrewed: Close all gas connections (with sealing plugs) to protect internal gas paths against moisture, dust or dirt penetrating
- Close off open electrical connections dust-tight
- Protect the control unit against sharp-edged objects. Possibly attach a suitable protective cover (e.g. made of cardboard or hard foam)
- Select a dry, well-ventilated room for storage
- Pack the device (e.g., in a plastic sack).
- If high air humidity can be expected: Enclose a drying agent (e.g., silica gel) in the packing

10.3 Shipping for repair

Before shipping:

- ▶ Contact your local SICK representative. The addresses are on the back cover of the Operating Instructions.
- ▶ Your SICK representative can advise you whether the defective device can be repaired locally or whether it would more advantageous for you to return the device for repair.
- ▶ Observe the following when returning the device to SICK:
 - Flat rates for repairs (concerning duration and costs)
 - Safety protection for the transport
 - Replacement devices or putting the device back into operation by SICK Service



NOTICE

Correct device preparation for return delivery

- ▶ Clean all device components.
- ▶ Use the original packaging for the transport.
- ▶ Complete the Non-Risk Declaration (NRD) and lay these clearly visible in the packaging.

Without the Non-Risk Declaration, the device will either be cleaned by a third-party company at the customer's expense or the package will not be accepted.

Clean the device before returning

Prerequisite: Switch device free from voltage

Clean surfaces and parts with media contact:

- ▶ Remove loose contamination with compressed air
- ▶ Remove adhering contamination with a mild soap solution and a soft cloth



NOTICE

Close the enclosure before cleaning so that no fluid can penetrate.

10.4 Transport

- Protect the housing before transport.
- Use the original packaging for transport whenever possible alternatively a suitable padded stable packaging.
- A transport container with adequate stability can also be used. Protect the device with padding from shocks and vibrations, and thoroughly secure the device in place inside the transport container. Ensure adequate clearance from the walls of the transport container.



NOTE

Accompanying documents when shipping for repairs: [see "Shipping for repair", page 99](#).

10.5 Disposal

The device can easily be disassembled into its components which can then be sent to the respective raw material recycling facilities.

**NOTE**

The following subassemblies contain substances that may have to be disposed of separately:

- Electronics: Capacitors, rechargeable batteries, batteries.
 - Display: Liquid of LC display.
 - Sample gas filter: Sample gas filters could be contaminated by pollutants.
 - All lines with sample gas contact could be contaminated with pollutants.
-

11 Technical data



NOTE

The Technical data depend to some extent on the individual equipment of your analyzer.

- ▶ See the system documentation provided for the configuration of your analyzer.

11.1 Dimensional drawings

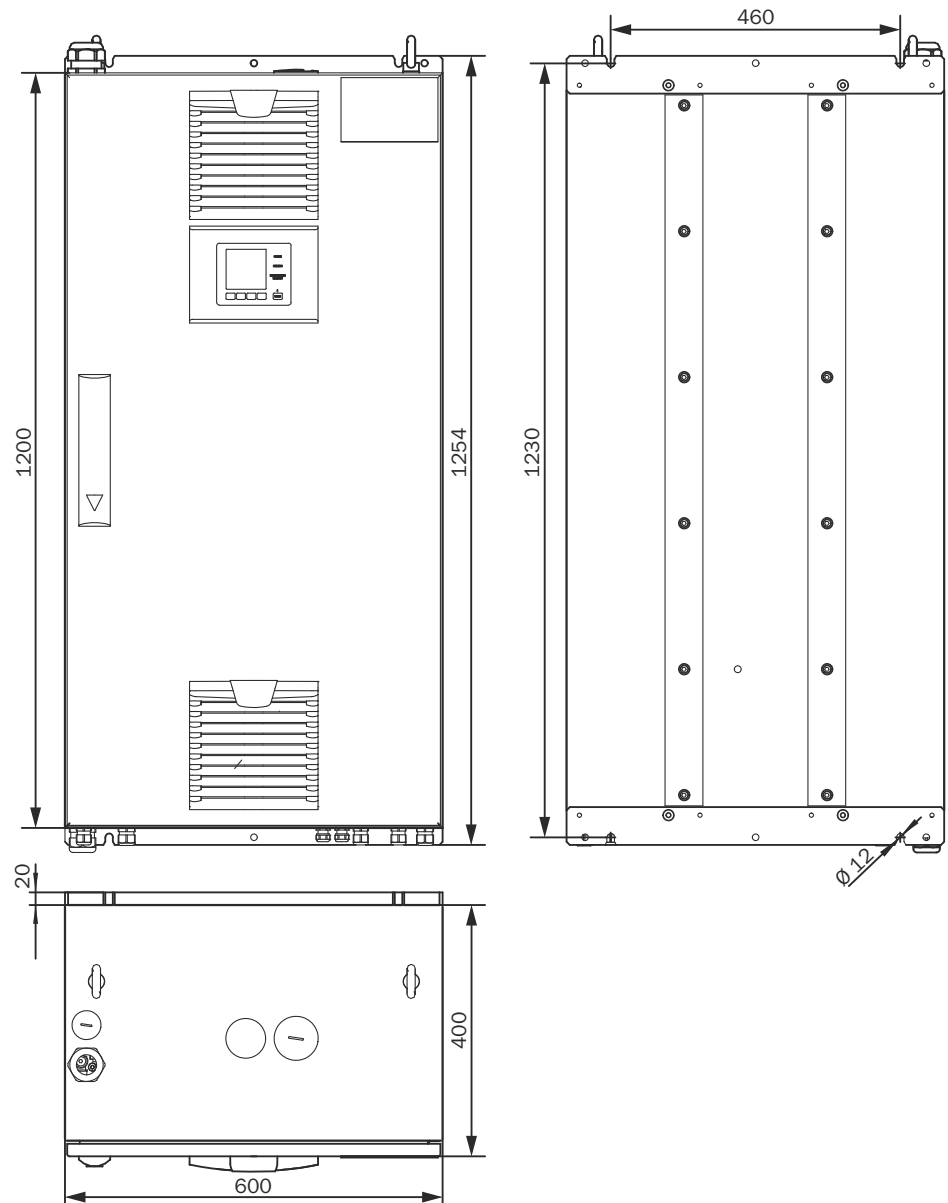

Figure 118: Analyzer cabinet - dimensional drawing



NOTICE

Observe clearances:

- Top: 30 cm
- Bottom: 20 cm

11.2 Design

Table 11: Design

Design	
Design	1 x wall housing
Material, general	Steel plate, aluminium cast
Dimensions	see "Dimensional drawings", page 101
Installation	Wall fitting
Weight	Approx. 120 kg
Materials with media contact	<ul style="list-style-type: none"> Stainless steel 1.4571 PTFE Aluminium (coated)
Degree of protection	IP 54

11.3 Measuring parameters

Table 12: Sample gases

Variants	Components
DeSO _x	SO ₂ , CO ₂ , H ₂ O, optional O ₂
DeNO _x	NO, NO ₂ , H ₂ O, optional O ₂
Emission	SO ₂ , CO ₂ , NO, NO ₂ , CO, CH ₄ , NH ₃ , H ₂ O, optional O ₂

Table 13: Measured variables

Number of measured variables	
Number of measured variables	Max. 9

Table 14: Measuring method

Measuring method	
Measuring method	Hot extractive

Table 15: Spectral range

Spectral range	
Spectral range	2000 ... 11000 nm

Table 16: Sample volume

Sample volume	
Sample volume	200 ... 300 l/h

Table 17: Sample gas - measuring range

Component	Measuring range
SO ₂	0 ... 30 ppm; 0 ... 2000 ppm
CO ₂	0 ... 25% by vol.
O ₂	0 ... 21% by vol.
NO	0 ... 300 ppm; 0 ... 2000 ppm
NO ₂	0 ... 200 ppm; 0 ... 500 ppm
CO	0 ... 200 ppm; 0 ... 2000 ppm
NH ₃	0 ... 50 ppm; 0 ... 500 ppm
CH ₄	0 ... 500 ppm; 0 ... 10000 ppm

Component	Measuring range
H ₂ O	0 ... 40% by vol.

Table 18: Measuring point switchover

Measuring point switchover	
Measuring point switchover	Max. 2 measuring points (optional 8 measuring points)

Table 19: Measured value characteristics

Measured value characteristics	
Measuring principle	Photometric
Measuring precision	< 2% of the respective full scale value
Detection limit	< 2% of the respective full scale value
Sensitivity drift	< 2% of the respective full scale value per week
Zero drift	< 2% of the respective full scale value per week
Span drift	< 2% of the respective full scale value per week
Setting time t ₉₀	< 140 s, total measuring path as from probe extraction

11.4 Ambient conditions

Table 20: Ambient conditions - in operation

Ambient conditions in operation	
Installation location	Below deck
Ambient temperature	+0 ... +45 °C
Relative humidity	< 90% (without condensate)
Air pressure	900 ... 1100 hPa
Degree of protection	IP 54

Table 21: Ambient conditions - in storage

Ambient conditions in storage	
Ambient temperature	-20 ... +70 °C
Relative humidity	< 90% (without condensate)

11.5 Sample gas conditions

Table 22: Sample gas characteristics

Sample gas at the measuring point	Characteristic
Process temperature	10 ... 550 °C
Sample gas temperature subassembly: <ul style="list-style-type: none"> • Sample gas probe • Sample gas line • Cell 	Temperature: <ul style="list-style-type: none"> • Approx. 200 °C • Approx. 200 °C • Approx. 200 °C
Process pressure	-20 ... +200 hPa relative
Dust load	< 200 mg/m ³

11.6 Heated sample gas lines

Table 23: Sample gas line - characteristics

Sample gas line	
Length	Max. 35 m
Ambient temperature	-20 ... 80 °C
Working temperature	Max. 200 °C
Temperature control	1 x Pt100 1 x additional Pt100 as reserve
Power supply	115 V or 230 V
Power consumption	90 VA/m
Degree of protection	IP 54

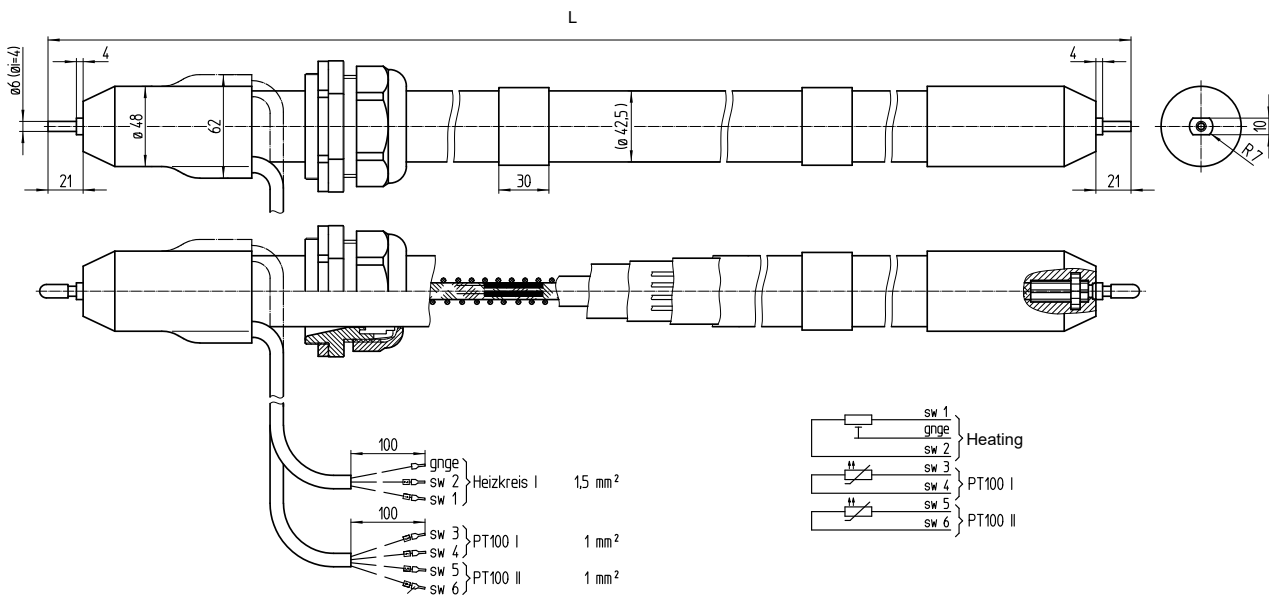

Figure 119: Heated sample gas line

11.7 Tube bundle cable

No.	Designation	Function	Dimension
①	Power supplies	Lines 1 and 2: Gas sampling filter Lines 3 and 4: Probe tube (optional)	4 x 1.5 mm ²
②	Signal lines (Pt100)	Lines 1 and 2: Gas sampling filter Lines 3 and 4: Probe tube (optional)	4 x 1.0 mm ²
③	Grounding conductor (gnge)	Ground	1 x 4.0 mm ²
④	PTFE hose (white)	Zero gas	DN 4/6
⑤	PA hose (black)	Control air main valve	DN 6/8
⑥	PA hose (blue)	Backflush air	DN 6/8

11.8 Interfaces and protocols

Table 24: Interfaces and protocols

Operation and interfaces	
Operation	Via LC-Display or SOPAS ET software, several operating levels, password-protected
Display and input	Black-and-white foiled screen with function buttons Status LEDs <ul style="list-style-type: none"> • "Power" • "Malfunction" • "Maintenance request"
Analog outputs	Optional
Digital inputs/outputs	Optional
Data interface	1 x Ethernet (Modbus TCP/IP)
Profibus	Optional
Profinet	Optional
Remote maintenance	SICK MPR (optional)
PC operation	SOPAS ET via Ethernet

11.9 Power supply

Table 25: Power supply

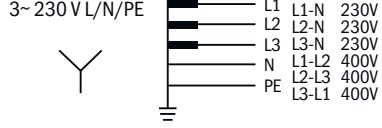
Power supply	
Supply voltage (preset)	<p>IT network (without neutral conductor, not grounded)</p> <ul style="list-style-type: none"> • 3~230 V, PE • 3~208 V, PE <p>3~ 230 V L/L/PE</p>  <p>Figure 120: IT network switching</p> <p>TN(S) network (with neutral conductor, grounded)</p> <ul style="list-style-type: none"> • 3~230 V, N, PE • 3~115 V, N, PE <p>3~ 230 V L/N/PE</p>  <p>Figure 121: TN(S) network switching</p> <p>Further variants optional (e.g.: 1~230 V, 2~208 V)</p> <p>► Refer to the system documentation provided for the default value.</p>
Frequency	50/60 Hz

Power supply	
Power consumption <ul style="list-style-type: none"> Analyzer Heated sample gas line Gas sampling system Heated probe tube 	Power consumption <ul style="list-style-type: none"> Approx. 1000 VA Approx. 95 VA/m Approx. 450 VA Approx. 450 VA

Table 26: Line cross-sections

Line cross-sections (relative to leads with ferrules)	
<ul style="list-style-type: none"> CAN RS485 	Line cross-section: 0.14 ... 1.5 mm ² AWG28 ... AWG16
<ul style="list-style-type: none"> Pt100 inputs 24 V DC valve outputs Digital inputs Relay outputs (potential-free) 	Line cross-section: 0.25 ... 2.5 mm ² AWG30 ... AWG12
<ul style="list-style-type: none"> External heating circuits 	Line cross-section: 0.25 ... 4.0 mm ² AWG30 ... AWG10
<ul style="list-style-type: none"> Power supply 	Line cross-section: 0.5 ... 6.0 mm ² AWG20 ... AWG7

Table 27: Optional interfaces

Interfaces (optional)	
Digital outputs	4 outputs, 24 V, 0.5 A
Digital inputs	Electrically isolated, 24 V, 0.3 A
Analog outputs	Optional

11.10 Connections in analyzer

Power supply - connection / fuses

The power supply is located on the left on the analyzer.

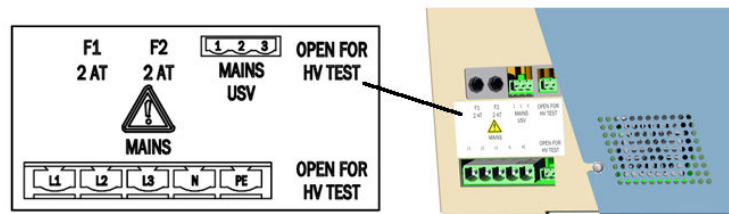

Figure 122: Power supply connections

Table 28: Power supply - connections

Name	Supply
MAINS USV (3-pole)	Power supply for electronics unit (internal)
MAINS (5-pole)	External power supply
F1	Internal
F2	Internal

Electronics fuses

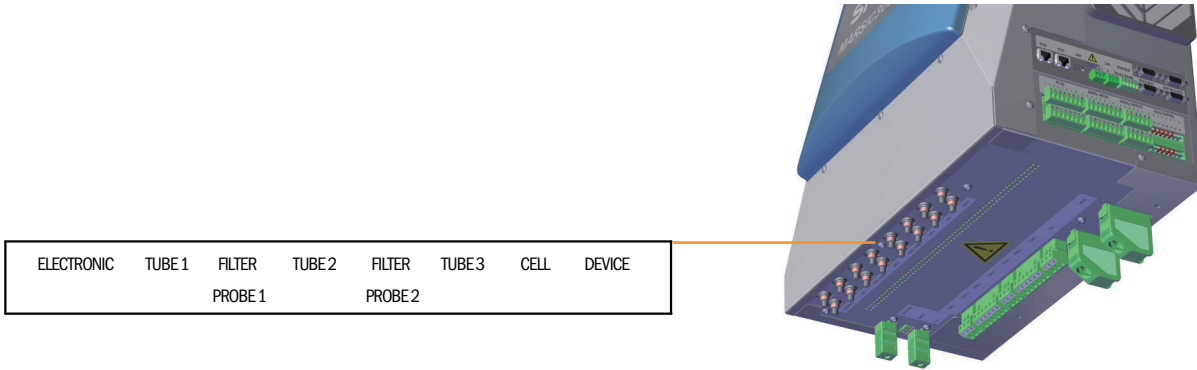

Figure 123: Electronics connections

Table 29: Electronics connections

Name	Fuse for
ELECTRONIC	Electronics
TUBE 1	Sample gas line 1
FILTER/PROBE 1	Filter heater 1
TUBE 2	Sample gas line 2
FILTER/PROBE 2	Filter heater 2
TUBE 3	Sample gas line 3
CELL	Sample gas cell
DEVICE	Device

Connections for heated components

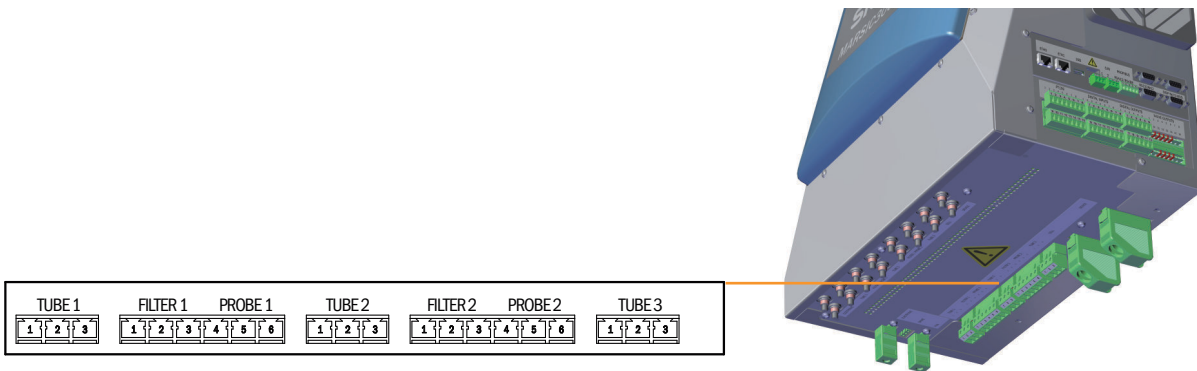

Figure 124: Connections for heated components

Table 30: Connections - pin assignment

Plug	Subassembly	Pin	Assignment	Hose bundle line number ¹	
TUBE 1	Sample gas line 1	1	L (L)		
		2	N (L)		
		3	PE		
FILTER1	Gas sampling unit filter 1 (Lines from hose bundle line)	1	L (L)	4x1.5 mm ²	1
		2	N (L)		2
		3	PE	1x4 mm ²	GNYE

Plug	Subassembly	Pin	Assignment	Hose bundle line number ¹	
PROBE1	Gas sampling unit probe tube 1 (Lines from hose bundle line)	4	L (L)	4x1.5 mm ²	3
		5	N (L)		4
		6	PE (not connected)		
TUBE2	Sample gas line 2	1 ... 3	As for TUBE1		
FILTER2	Gas sampling unit filter 2	1 ... 3	As for FILTER1		
PROBE2	Gas sampling unit gas sampling probe 2	4 ... 6	As for PROBE1		
TUBE3	Sample gas line 3				

¹ The connections must match the connections on the gas sampling unit.

Connections for interfaces and SD card

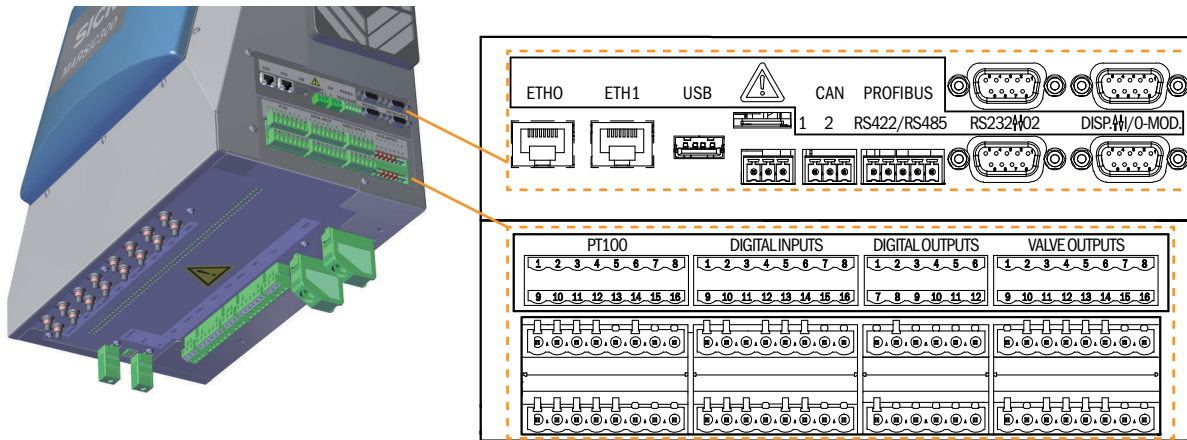

Figure 125: Connections overview

Table 31: Data interfaces - overview

Plug	Connection for
ETH0	Ethernet (e.g. SOPAS ET), MPR (remote maintenance), communication via Modbus TCP
ETH1	Internal
USB	Internal
SD card	SD card (on the right, next to USB)
CAN1	Internal
CAN2	Internal
RS422, RS485	Internal
RS232 (top plug)	Internal
O2 (bottom plug)	O ₂ sensor
DISP (top plug)	Display
I/O-MOD (bottom plug)	Internal

Pt100 and signal connections

Table 32: Overview - pin assignment and signals

Plug	Subassembly	Pin	Assignment	Hose bundle line number ¹		
Pt100	Sample gas line 1	1	Pt100 +			
		2	Pt100 -			
	Gas sampling unit filter 1	3	Pt100 +	4x1.0 mm ²	1	
		4	Pt100 -		2	
	Gas sampling unit probe tube 1	5	Pt100 +		3	
		6	Pt100 -		4	
	Not connected	7				
		8				
	Sample gas line 2	9, 10	As above			
	Gas sampling unit filter 2	11, 12	As above	4x1.0 mm ²		
	Gas sampling unit probe tube 2	13, 14	As above			
	Sample gas line 3	15	Pt100 +			
		16	Pt100 -			
	DIGITAL INPUTS	Digital input 1	1	+ 24 V		
			2	+ Signal		
			3	- Signal		
4			GND			
Digital input 2		5 ... 8	As above			
Digital input 3		9 ... 12	As above			
Digital input 4		13 ... 16	As above			
DIGITAL OUTPUTS	Digital output 1	1	NC			
		2	COM			
		3	NO			
	Digital output 2	4 ... 6	As above			
	Digital output 3	7 ... 9	As above			
Digital output 4	10 ... 12	As above				
VALVE OUTPUTS	Valves		Internal			

¹ The connections must match the connections on the gas sampling unit.

11.11 Circuit breakers

The circuit breakers are located at the bottom of the electronics unit.

The circuit breakers are labeled.

When a circuit breaker has triggered:

- ▶ Press the circuit breaker pin back in again.
If this does not work:
 - ▶ Wait for a few minutes (cooling down phase) and then press the pin back in again.
If this does not work: Check the subassembly and replace when necessary.

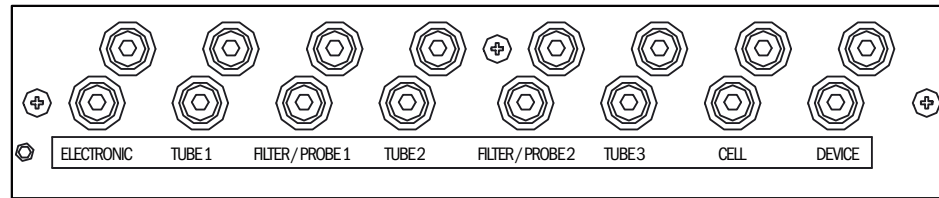

Figure 126: Circuit breakers

11.12 Supply gases



NOTICE

Risk of contamination of analyzer

- ▶ Observe the specified quality of the instrument air.
- ▶ If required, provide an instrument air conditioning.

Table 33: Supply gases

Gas	Quality	Inlet pressure	Flow rate
Instrument air (zero gas quality)	Particle size max. 5 µm Pressure dew point max. -40 °C Oil content max. 0.01 mg/m ³ ISO 8573-1:2010 [1:2:1] [SO ₂ ≤ 0.1 ppm] [CH ₄ ≤ 3 ppm] [N ₂ O ≤ 1 ppm]	600 ... 700 kPa (6.0 ... 7.0 bar)	Approx. 350 l/h
Instrument air solely as induction air for ejector	Particle size max. 5 µm Pressure dew point max. +3 °C Oil content max. 0.1 mg/m ³ ISO 8573-1:2010 [1:4:2]	500 ... 700 kPa (5.0 ... 7.0 bar)	Approx. 1300 l/h
External span gas	Precision: ± 2 % Concentration: 80% ... 100% of measuring range The span gas must comply with the specifications of the standards to be applied (e.g., MARPOL Annex VI)	Max. 400 kPa (4.0 bar)	Approx. 350 l/h

11.13 Tube connections

Table 34: Tube connections

Connection	Dimension
Sample gas inlet	Clamping ring screw connection 6 mm
Ejector induction air	DN 6/8
Span gas inlet	Clamping ring screw connection 6 mm
Gas outlet	DN 8/10

11.14 Torques

Tighten all screw connections, for which no tightening torque or no pretension force is specified in drawings or Assembly Instructions, according to VDI 2230.

Exceptions to this rule are all connections with screws that are not screw connections in the real sense. This includes hose clips, cable glands, screw fittings, gas connections, screws for circuit boards etc. Tighten these screw fittings as evenly as possible with a much lower torque (hose clips 1 Nm, other screw fittings according to manufacturer specifications).

Select the next lowest torque valid for the screw for mixed materials and special screws such as relieved screws.

The friction coefficient serving as basis is (screw fitting without lubrication) $\mu_k = \mu_G = 0.14$. The calculated values are valid for room temperature ($T = 20^\circ\text{C}$).

Table 35: Torques

Size M	Pitch P	Tightening torque Ma (Nm)					
		3.6	4.6	5.6	8.8, A2 u. A4-80	10.9	12.9
1.6	0.4	0.05		0.05	0.17		0.28
2	0.45	0.1		0.11	0.35		0.6
2.5	0.45	0.21		0.23	0.73		1.23
3	0.5		0.54	1	1.3	1.7	2
3.5	0.6		0.85	1.3	1.9	2.6	3.2
4	0.7		1.02	2	2.5	4.4	5.1
5	0.8		2	2.7	5	8.7	10
6	1		3.5	4.6	10	15	18
8	1.25		8.4	11	25	36	43
10	1.5		17	22	49	72	84
12	1.75		29	39	85	125	145
14	2		46	62	135	200	235
16	2		71	95	210	310	365
18	2.5		97	130	300	430	500
20	2.5		138	184	425	610	710
22	2.5		186	250	580	830	970
24	3		235	315	730	1050	1220
27	3		350	470	1100	1550	1800
30	3.5		475	635	1450	2100	2450
33	3.5		645	865	2000	2800	3400
36	4		1080	1440	2600	3700	4300
39	4		1330	1780	3400	4800	5600

12 Annex

12.1 Error messages and possible causes

Current pending messages are shown on the device display.

A combined list of messages is included in SOPAS ET (see "MARSIC300 Technical Data").



NOTE

The following Table only includes those messages with classification "X" that are important for information.

Messages not included in the following Table have no further significance for operation.



NOTE

Display of current device state data: Menu Diagnosis/System param.

C = Classification

F = Failure

M = Maintenance request

U = Uncertain

E = Extended

Trigger: System

Table 36: Error codes - System

Code	Error text	C	Description	Possible clearance
S001	Temperature too high	F	Measuring cell temperature too high	When T < 356 °C: Replace electronics unit. When T >= 356 °C: Check plug-in connector on electronics unit. When plug OK: Replace cell.
			Optic head temperature too high	When T < 356 °C: When housing temperature >= 55 °C: Check housing fan. When housing temperature < 55 °C: Replace electronics unit. When T >= 356 °C: Check plug-in connector on electronics unit. When plug OK: Replace Analyzer module.
			Temperature of heating for a subassembly too high	Check device documentation to clarify which subassembly is affected. When T < 356 °C: Replace electronics unit. When T >= 356 °C: Check subassembly plug-in connector. When plug OK: Replace subassembly
			LPMS01 (1/2 control) temperature too high	When housing temperature < 55 °C: Electronics unit fan functioning? Yes: Replace electronics unit. No: Replace Analyzer module. When housing temperature >= 55 °C: Check housing fan.
			LPMS02 (power electronics) temperature too high	When housing temperature < 55 °C: Replace electronics unit. When housing temperature >= 55 °C: Check housing fan.

Code	Error text	C	Description	Possible clearance
S002	Temperature too low	F	After x minutes	<p>Check system documentation to clarify which subassembly is affected (heating circuit 1 ..7).</p> <ul style="list-style-type: none"> Temperature displayed < -30 °C: Pt100 short circuit: Replace subassembly For heated sample gas line: Connect reserve Pt100 For analyzer: Replace Analyzer module For optic head: Replace Analyzer module Reset on circuit breaker under electronics unit possible: Check all cables involved for damage (see "Circuit breakers", page 109) Check all plugs are plugged correctly. Reset not possible: Replace subassembly affected
S004	Flow too low	F	Flow too low	Sample gas flow and instrument air flow too low: Replace cell
				Sample gas flow too low and instrument air flow OK: Gas sampling system defective
				Instrument air flow too low and sample gas flow OK: Check all hose connections. When all hose connections OK: Replace valve block.
S005	Pressure too high	F	Pressure too high	<p>Only instrument air pressure too high:</p> <ul style="list-style-type: none"> Check and set connected instrument air. Set correct pressure on pressure reducer unit.
				<p>Only sample gas pressure too high:</p> <ul style="list-style-type: none"> Set sample gas pressure within device specification
				<p>Instrument air and sample gas pressure too high:</p> <ul style="list-style-type: none"> Exhaust gas hose crimped/blocked Counter-pressure in exhaust duct too high Check all hose connections <p>If this does not work:</p> <ul style="list-style-type: none"> Replace the pressure control module Otherwise: Replace Analyzer module
S006	Pressure too low	F	Pressure too low	Replace pressure control module.
S008	Chopper	F		<p>24 V power supply malfunction: Replace electronics unit.</p> <p>24 V power supply OK: Replace Analyzer module.</p>
S009	Motor filter wheel 1	F	Filter wheel motor does not detect reference position	<p>24 V power supply malfunction: Replace electronics unit.</p> <p>24 V power supply OK: Replace Analyzer module.</p>
S010	Motor filter wheel 2			
S011	Motor filter wheel 3			
S012	Emitter	F		<p>Emitter voltage incorrect: Replace electronics unit.</p> <p>Emitter voltage OK and emitter power incorrect: Replace emitter.</p>
S013	5 Volt power	F		Replace electronics unit.
S014	24 Volt power	F		Replace electronics unit.
S015	Detector signal	F		Replace Analyzer module.
S016	Ref. energy too low	F		If further error messages are pending: Clear corresponding error.
				If no further error messages are pending: Replace cell.

Code	Error text	C	Description	Possible clearance
S024	No active component	F	When all "active" checkmarks of all components are inactive	Check in SOPAS ET.
S025	Evaluation module failure	F	Evaluation module could not be started	"Load backup": Menu Maintenance/Save parameters. If error remains: "Load default setting" . If error remains: Replace electronics unit.
S026	Evaluation mod. file error	F	Files for Evaluation module not created (espec, config, condition, measval)	
S033	Dev. zero point too high	M	Configured for measuring component	Check zero gas for pressure and cleanness. Perform maintenance on compressed air conditioning unit Perform manual zero point adjustment (menu: Adjustment/Zero point). If deviation still too high: Replace Analyzer module
S034	Configuration I/O module	M	CONF (I/O) configuration error, module found does not correspond to nominal configuration	Check I/O module, check configuration: IO hardware plan
S035	Ref. energy too low	M		If further error messages are pending: Clear corresponding error. If no further error messages are pending: Replace cell.
S036	O2 sensor failure	M	Error bit O2 Error=1	Please contact SICK Customer Service
S038	Channel 1 error	M	OVO (I/O) signals that the desired current is not reached on Analog module connection (node y, module z).	Check I/O module, cable damage
S039	Channel 2 error	M		
S040	Flow too high	M	Flow too high	Test pressure sensors with program "Maintenance/Maint Sys./Test pressure sensors". If this does not work: Replace pressure control module.
S041	Flow too low	M	Flow too low	Please contact SICK Customer Service
S042	Controller IO or HC busy	M	BSY (I/O and HC3X) signals that the module microcontroller is still executing the previous command	
S043	Emitter weak	M		Replace emitter.
S045	dev. span gas adjust too high	M	When F_Medium calculation is refused because outside tolerable range; Configured for measuring component	Perform adjustment with zero gas and span gas. If error remains: Replace Analyzer module.
S046	dev. Int. adjust too high	M	When F_Medium calculation is refused because outside tolerable range; Configured for measuring component	Perform "Internal reference" adjustment. If error remains: Replace Analyzer module.
S047	dev. O2 adjust too high	M	When F_Medium calculation is refused because outside tolerable range; Configured for measuring component	Check span gas, check entry for span gas concentration.
S048	alarm O2 measure value	M		
S049	FlashCard not recognized	M	FlashCard not recognized	Please contact SICK Customer Service
S050	adjust factor is Zero	M	If one of factors F_Medium or F_Filter in range $-0,000001 < x < 0,000001$	Check span gas, check entry for span gas concentration
S057	Energy too high	U	When at least one energy value $> 5 * \text{EnergieMAX}$	Please contact SICK Customer Service
S058	Energy too low	U	Energy too low	If a further emitter error is pending: Replace emitter. Otherwise replace Analyzer module
S072	Module not found	E	I/O (EXIST)	Please contact SICK Customer Service
S089	Zero	E	New zero recorded	Extinction value set to zero is displayed
S090	AF	E	F_Filter has been recalculated	New factor determined and measured value from adjustment displayed
S091	Communication problem	E	Internal communication problem	Please contact SICK Customer Service

Code	Error text	C	Description	Possible clearance
S092	Adjustment canceled	E	Adjustment canceled	Restart adjustment. If this does not work: Please contact SICK Customer Service
S093	Dark measurement	E		
S094	System start	E		
S095	Adjust. zero canceled	E		
S096	Backup done	E		
S097	Backup denied	E		
S098	AM	E		
S112	failure IO-Node	E		
S113	Check sum error	F	BCK (I/O) shows the transfer made from Master to Slave (controller) had an incorrect checksum and the Slave did not save the data.	Check I/O module, cable damage
S114	Communication error	F	COM (I/O) communication error with an I/O module.	
S115	High/low voltage	F	PFO (I/O) signals the internal voltage monitoring of the 5 V and 24 V supply voltages exceed or underflow a range.	Please contact SICK Customer Service
S116	Output without current	F	TOO (HC3X)	

This Table contains solution proposals that can only be processed by specially trained personnel.

Trigger: Evaluation process

Table 37: Error codes - Evaluation process

Code	Error text	C	Possible clearance
E001	Operating system error	U	Please contact SICK Customer Service
E002	Temp. too low		
E003	Incorrect configuration		
E004	Incorrect configuration		
E005	Internal file error		
E006	Incorrect configuration		
E007	Internal file error		
...			
E009			
E010	Incorrect configuration		
...			
E012			
E013	Internal file error		
...			
E021			
E022	Resolution too high/low		
E023	Numeric error		
E024	Incorrect configuration		
E025	Internal file error		
E026	Numeric error		
E027	Incorrect configuration		
E028	Incorrect configuration		
E029	Unknown error		
E030	Operating system error		
E031	Operating system error		
E032	Internal file error		
...			
E034			
E035	Numeric error		
E036	Syntax error		
E037	Error during processing		
E038	Extinction too high		
E039	Internal file error		
E040	Internal file error		
E097	Evaluation uncertain		
E098	Medium temp. too high/low		
E099	Medium pressure too high/low		
E100	Medium flow too high/low		
E101	Measured value too high/low		
E102	Evaluation uncertain		
E103	Evaluation uncertain		

Trigger: Sequence control programs

Table 38: Error codes - Sequence control program

Code	Triggered by sub-assembly	C	Message	Clearance
M001 ... M009	Internal heating	F	Alarm from "device"	" device " = triggering subassembly Clearance see above: S001 and S002
M010 ... M029	External heating	F	Alarm from "device"	" device " = triggering subassembly Clearance see above: S001 and S002
M034 ... M045	System	X	System xx disabled by user	No action required
M046 ... M057	Measuring point 1 ... Measuring point 12	M	Flow alarm (measuring)	Clearance see above: S004 Next measuring point activation after message acknowledged

Table 39: Further error codes

Code	Triggered by sub-assembly	C	Message	Clearance
M058	System	F	Flow alarm (measuring)	Clearance see above: S004 Next measuring point activation after message acknowledged
M060	Program	M	Adjust zero not started	No action necessary
M062	Leak tightness check	X	Test passed	Repeat test and observe messages displayed; Check seating of connections, disconnect heating hose from cell and close sample gas inlet off with dummy plug (from leak tightness check set) If leaky: Exchange pressure control module and cell otherwise exchange gas sampling system
M063		M	Test failed	
M064			Pressure not reached	
M065			Air valve not closed	
M066			Leakage > Limit	
M067		X	Deviation="xx"	Serves as information "xx" = pressure loss [hPa] during measuring time.

Table 40: Further error codes

Code	Triggered by sub-assembly	C	Message	Clearance
M069	Debug	X	Internal message	No action necessary
M070	Light Source	M	Lifetime exceeded	Replace emitter
M071	Filter Unit	M	Lifetime filter exceeded	Replace gas sampling system filter
M072	Valve driver module	F	Temperature > Limit	Other temperature error pending? Then see S001 above; Otherwise replace valve block
M073	Power Supply	X	115V	Serves as information No action necessary

Code	Triggered by sub-assembly	C	Message	Clearance
M074	Program	X	Stop by internal failure	No action necessary
M075		X	Cancelled by user	No action necessary
M076	CELL	M	Lifetime filter exceeded	Replace cell inlet filter

Table 41: Further error codes

Code	Triggered by sub-assembly	C	Message	Clearance
M086	Pressure	X	Sensors ok	No action necessary
M087		X	Sensors adjusted	
M088		M	Sensors not OK	Sample gas outlet open to environment? If no blockages: Exchange pressure control module
M089	Measuring point	M	All disabled	See additional message: Clear pending error; check external signal
M090 ... M101	System	X	Measuring sample point 1 ... Measuring sample point 12	No action necessary
M102 ... M113		X	SP1 disabled by ext signal ... SP12 disabled by ext signal	

12.2 Consumable parts, wearing parts and spare parts

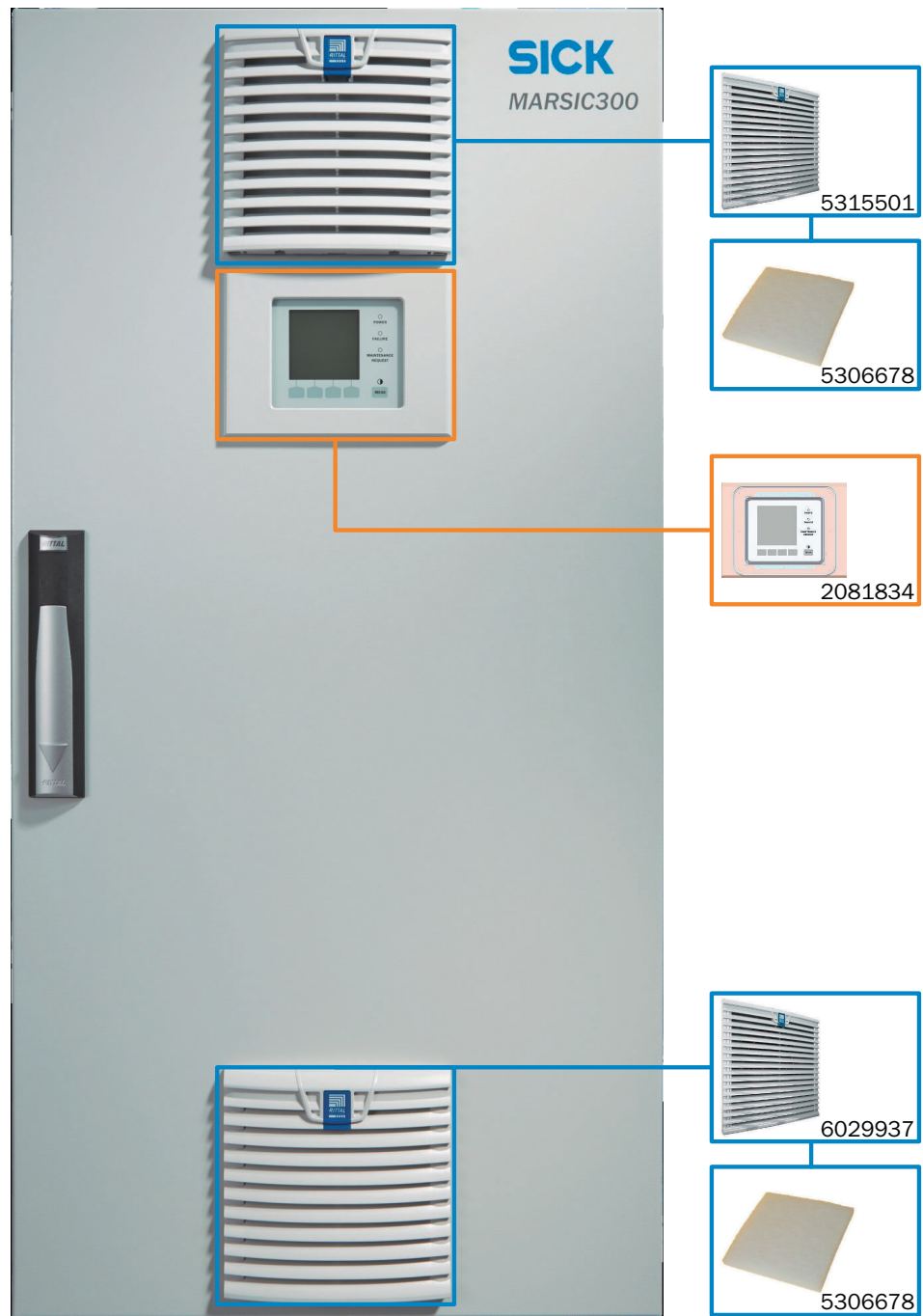

Figure 127: Spare parts overview, exterior

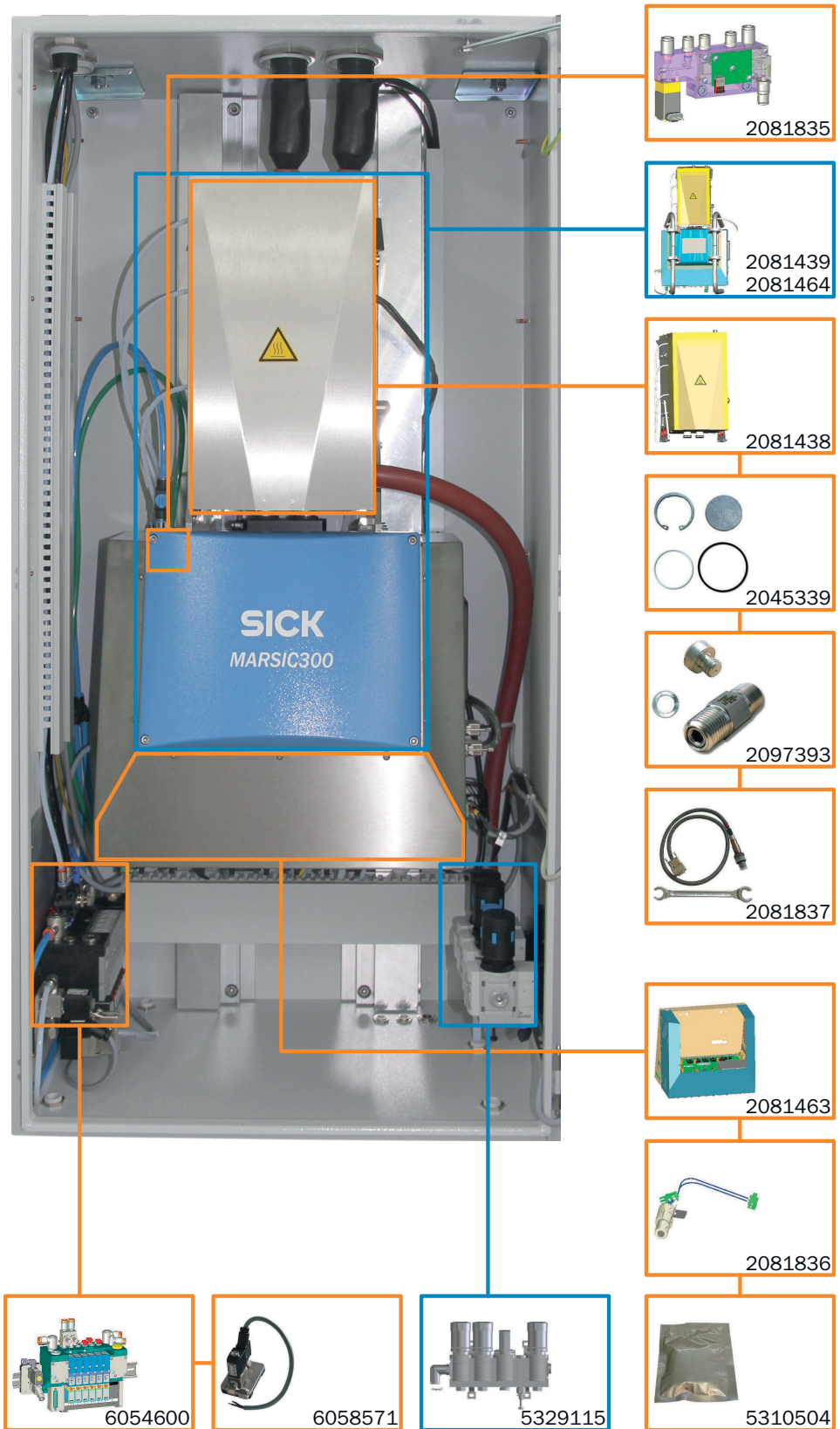

Figure 128: Spare parts overview, interior

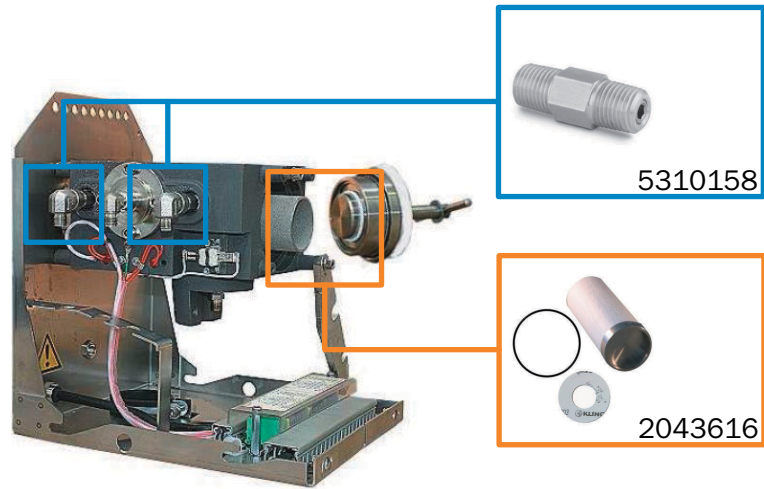

Figure 129: Spare parts, SFU



Figure 130: Spare parts, instrument air conditioning



Figure 131: Spare parts, instrument air conditioning

Table 42: Spare parts

Spare part, gas sampling unit	Part number
Service kit for gas sampling filter	2043616
Non-return valve	5310158

Analyzer spare parts	Part number
Analyzer module, complete	2081439
Analyzer module, loan module	2081464
Cell incl. tubes	2081438
Oxygen sensor, complete	2081837
Electronics unit, complete	2081463
Pressure control module, partial vacuum	2081835
IR source	2081836
Drying agent bag	5310504
Pressure reducer unit	5329115
Valve block, complete with span gas valve	6054600
Span gas valve	6058571
Device display	2081834
Housing fan	6029937
Filter pad	5306678
Maintenance set, cell inlet filter	2045339
Non-return valve, cell filter	2097393

Spare parts, external instrument air cleaning unit (optional)	Part number
External compressed air conditioning unit FRL-SF0025	5320896
Filter set for external compressed air conditioning FRL-SF0025	5327075
Prefilter for oil mist separator for FRL-SF0025	2082301
Spare filter element for oil mist separator	5332124
External compressed air conditioning unit M condensate drain	6070177
Filter unit for external compressed air conditioning unit M condensate drain	5339994

Sample gas lines and accessories	Part number
Heated sample gas line 1 m, 115V	6035901
Heated sample gas line 5 m, 115V	6035905
Heated sample gas line 10 m, 115V	6035910
Heated sample gas line 15 m, 115V	6035915
Heated sample gas line 20 m, 115V	6035920
Heated sample gas line 25 m, 115V	6035925
Heated sample gas line 30 m, 115V	6035930
Heated sample gas line 35 m, 115V	6035935
Intermediate lengths up to 35 m, 115V	60359XX (XX = length in meters)
Heated sample gas line 1 m, 230V	6031101
Heated sample gas line 5 m, 230V	6031105

Sample gas lines and accessories	Part number
Heated sample gas line 10 m, 230V	6031110
Heated sample gas line 15 m, 230V	6031115
Heated sample gas line 20 m, 230V	6031120
Heated sample gas line 25 m, 230V	6031125
Heated sample gas line 30 m, 230V	6031130
Heated sample gas line 35 m, 230V	6031135
Intermediate lengths up to 35 m, 230V	60311XX (XX = length in meters)
Tube bundle cable, per meter	6058443
PTFE tube 4/6	5310243
PTFE tube 8/10	5310246

Installation sets	Part number
Installation set (included in MARSIC300): <ul style="list-style-type: none"> • Tool for tube fitting/removal • Drying agent bag • Sealing plugs 6 mm, 8 mm, 10 mm • Silicone tube 12 x 6 mm • Plug cap 10 mm • Cable ties 	2081755
Installation set, extended: <ul style="list-style-type: none"> • 2 m PTFE tube, OD 6 x 1 mm • 5 m PTFE tube, OD 10 x 1 mm • 1 x tube cutter • 2 x cap nuts, clamping rings, support sleeve 6 mm • 1 x cap nut, clamping ring, support sleeve 10 mm 	2081839
Spare parts set, Swagelok connections	2075791
PTFE tube cutter	5329980
Test set, water QE	2095185
Spare parts, SFU	Part number
Non-return valve	5310158
Service kit for gas sampling filter	2043616

12.3 Compliances

Compliances

- MARPOL Annex VI and NTC 2008 - MEPC.177(58)
- Guidelines for exhaust gas cleaning systems - MEPC.184(59), MEPC.259(68)
- DNV GL Rules for Classification and Construction, Part VI Additional Rules and Guidelines Chapter 7, Guidelines for the Performance of Type Approvals, Test Requirements for Electrical / Electronic Equipment and Systems
- ABS Rules for steel vessels: 1-1-4/7.7, 1-1-Appendix 3 and 4, 4-8-3/1.7/ 1.9/ 1.11/ 1.17/ 4-9-8/13
- CCS Rules Chapter 2, Part 7 of China Classification Society Rules for Classification of Sea-going Steel Ships and its Amendments.
- EC Directive: LVD (Low Voltage Directive)
EN 61010-1: Safety requirements for electrical equipment for measurement, control and laboratory use

- EC Directive: EMC (Electromagnetic Compatibility)
EN 61326: Electrical equipment for measurement, control and laboratory use, EMC requirements
- Cross-sensitivity correction according to DIN EN 15267-1: Air quality - certification of automated measuring systems

Further standards and directives: See Declaration of Conformity provided with the device.

Electrical compliance

- CE
- DNV GL Rules, CCS, ABS, NVK

12.4 Licences

Liability disclaimer

The firmware for this device has been developed using Open Source Software. Any changes to the Open-Source components are in the general responsibility of the user. All warranty claims are excluded in this case.

The following liability disclaimer is valid for the GPL components in relation to the copyright holders: This program is distributed in the hope that it will be of use but, however, without any warranty; also without the implicit warranty for marketability or suitability for a particular purpose. Refer to the GNU General Public Licence for details.

With regard to the other Open-Source components, we refer to the liability disclaimers of the copyright holders in the licence texts on the CD delivered.

Software licences

In this product, SICK uses unchanged and, as far is necessary and in compliance with relevant licence conditions, changed Open Source Software.

The firmware of this device is therefore subject to the copyrights listed on the CD delivered. Please refer to the CD delivered for a complete list of the Open Source programs used as well as the relevant licence conditions.

Source codes

The source codes for the Open Source programs used in this device can be requested using the following email address: info.pa@sick.de. Please enter as subject "Open Source Software".

Australia

Phone +61 (3) 9457 0600
1800 33 48 02 – tollfree
E-Mail sales@sick.com.au

Austria

Phone +43 (0) 2236 62288-0
E-Mail office@sick.at

Belgium/Luxembourg

Phone +32 (0) 2 466 55 66
E-Mail info@sick.be

Brazil

Phone +55 11 3215-4900
E-Mail comercial@sick.com.br

Canada

Phone +1 905.771.1444
E-Mail cs.canada@sick.com

Czech Republic

Phone +420 234 719 500
E-Mail sick@sick.cz

Chile

Phone +56 (2) 2274 7430
E-Mail chile@sick.com

China

Phone +86 20 2882 3600
E-Mail info.china@sick.net.cn

Denmark

Phone +45 45 82 64 00
E-Mail sick@sick.dk

Finland

Phone +358-9-25 15 800
E-Mail sick@sick.fi

France

Phone +33 1 64 62 35 00
E-Mail info@sick.fr

Germany

Phone +49 (0) 2 11 53 010
E-Mail info@sick.de

Greece

Phone +30 210 6825100
E-Mail office@sick.com.gr

Hong Kong

Phone +852 2153 6300
E-Mail ghk@sick.com.hk

Hungary

Phone +36 1 371 2680
E-Mail ertesites@sick.hu

India

Phone +91-22-6119 8900
E-Mail info@sick-india.com

Israel

Phone +972 97110 11
E-Mail info@sick-sensors.com

Italy

Phone +39 02 27 43 41
E-Mail info@sick.it

Japan

Phone +81 3 5309 2112
E-Mail support@sick.jp

Malaysia

Phone +603-8080 7425
E-Mail enquiry.my@sick.com

Mexico

Phone +52 (472) 748 9451
E-Mail mexico@sick.com

Netherlands

Phone +31 (0) 30 229 25 44
E-Mail info@sick.nl

New Zealand

Phone +64 9 415 0459
0800 222 278 – tollfree
E-Mail sales@sick.co.nz

Norway

Phone +47 67 81 50 00
E-Mail sick@sick.no

Poland

Phone +48 22 539 41 00
E-Mail info@sick.pl

Romania

Phone +40 356-17 11 20
E-Mail office@sick.ro

Russia

Phone +7 495 283 09 90
E-Mail info@sick.ru

Singapore

Phone +65 6744 3732
E-Mail sales.gsg@sick.com

Slovakia

Phone +421 482 901 201
E-Mail mail@sick-sk.sk

Slovenia

Phone +386 591 78849
E-Mail office@sick.si

South Africa

Phone +27 10 060 0550
E-Mail info@sickautomation.co.za

South Korea

Phone +82 2 786 6321/4
E-Mail infokorea@sick.com

Spain

Phone +34 93 480 31 00
E-Mail info@sick.es

Sweden

Phone +46 10 110 10 00
E-Mail info@sick.se

Switzerland

Phone +41 41 619 29 39
E-Mail contact@sick.ch

Taiwan

Phone +886-2-2375-6288
E-Mail sales@sick.com.tw

Thailand

Phone +66 2 645 0009
E-Mail marcom.th@sick.com

Turkey

Phone +90 (216) 528 50 00
E-Mail info@sick.com.tr

United Arab Emirates

Phone +971 (0) 4 88 65 878
E-Mail contact@sick.ae

United Kingdom

Phone +44 (0)17278 31121
E-Mail info@sick.co.uk

USA

Phone +1 800.325.7425
E-Mail info@sick.com

Vietnam

Phone +65 6744 3732
E-Mail sales.gsg@sick.com

Detailed addresses and further locations at www.sick.com