



Maximise throughput, decrease costs and
achieve greater manufacturing flexibility

Tyre manufacturing

Proven automation solutions and local expertise to help you
overcome your toughest challenges





Unexpected machinery downtime increases your operational costs and severely affects your ability to meet production targets.

Challenged to guarantee throughput, reduce operating costs and quickly adapt production to support product innovation?

Global demand for tyres is increasing, creating genuine market opportunities, but also presenting challenges for manufacturing. Product innovation is essential for success, but this means your manufacturing equipment and processes must be flexible enough to support rapid changes. Competition has never been fiercer, and you must continually look for ways of reducing costs, such as through lower energy usage, minimising waste and improving automation. Where plants have been consolidated to streamline production, a reduction in throughput cannot be tolerated. However, increases to production puts greater stress on equipment, which leads to failures, downtime and affects your ability to meet targets.

“A capital-intensive, labour-intensive tyre factory needs to operate above 95% of capacity if it is to make money.”
– David Shaw, CEO-Tire Industry Research



“Production expenses have the greatest bearing on cost in the tyre industry, at around 70% of revenues.”
– Televisory Benchmarking, 2017



“Regulations, changes in materials, designs, and demands on tires are adding significant pressure to innovate.”
– Smithers Rapra, The Future of Tire Manufacturing to 2022



Boost throughput, cut downtime and ensure quality throughout the tyre-making process

Tyre manufacturing machinery and processes must meet increasingly challenging production and safety demands. By implementing Emerson’s fluid automation and control solutions, you will maximise production efficiency and availability through greater equipment performance, reliability and reduced maintenance. Our solutions will help ensure you achieve your targets, whilst always protecting equipment and workers. As you continue to innovate, our technology will support your need for flexible manufacturing solutions that meet changing production requirements. You will also lower operational costs through greater efficiency and reduced energy usage.

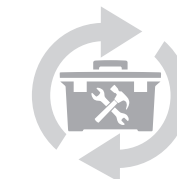

Reduce machinery downtime to ensure you meet production targets

- Extend periods between maintenance
- Prevent unexpected failure affecting production
- Reduce downtime through safety architecture simplification

“Every minute of downtime, caused by a malfunctioning third-party electronic input module, was costing a global tyre manufacturer money. With no spare available onsite, Emerson assembled and delivered replacement modules enabling production to restart within just 6 hours.”
– Global tyre manufacturer



Lower your manufacturing costs to ensure you remain competitive

- Increase the efficiency of operations through greater automation
- Reduce overall maintenance costs
- Install more machinery in a smaller footprint

“Emerson’s modular products and solutions are enabling us to make changes to the assembly and tyre building process easily over time. This means we can minimise downtime and restart production quicker, with significant financial benefits.”
– Leading tyre manufacturer, France



Provide flexible machinery that adapts with your continued product innovation

- Modify existing automation technology easily
- Commission and start-up new production lines faster
- Meet specific customer requirements now and as they change in the future

“Space is always at a premium. Easier maintenance and a reduced footprint provided by Emerson’s valve island made it an attractive solution.”
– Curing press manufacturer, Germany

With Emerson, you can overcome your tyre manufacturing challenges

Mixing equipment

- Improve consistent quality of materials with more precise process control. [Flow ▶ p10](#)

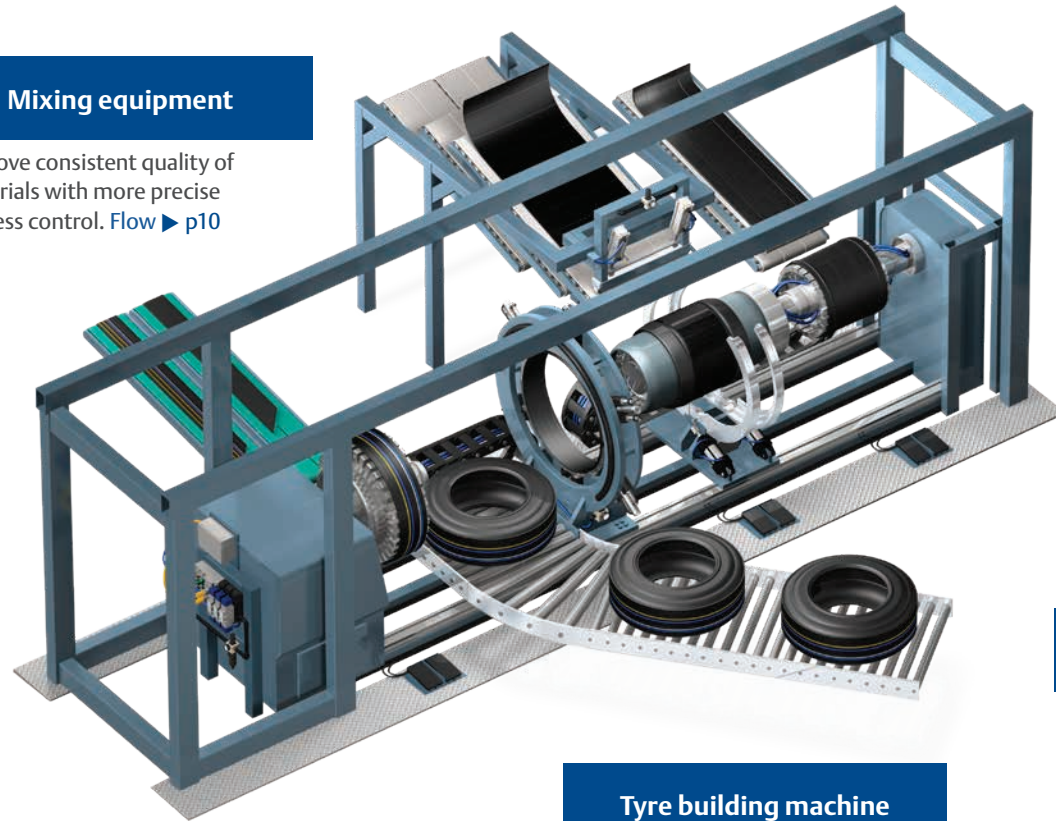

Fabric/wire calendars and extruder

- Increase reliability and material guidance precision of bead wiring and rubber coating. [Linear ▶ p8](#)
- Reduce commissioning time through onsite/pre-set tuning. [Proportional ▶ p13](#)
- Improve pneumatic system performance to avoid premature valve failures. [Preparation ▶ p12](#)

Tyre building machine

- Increase reliability and repeatability of your directional control. [Pneumatic ▶ p6](#)
- Easier valve commissioning using clear information from graphical interface. [Pneumatic ▶ p6](#)
- Increase visibility into health of pneumatic valves to reduce maintenance costs. [Pneumatic ▶ p6](#)
- Use proportional valves to control the inflation of the green tyre. [Proportional ▶ p10](#)

Curing press

- Tighter control of steam used to heat the mould and bladder pressure. [Flow ▶ p10](#)
- Increase process uptime through extended life of steam control valves. [Flow ▶ p10](#)
- Reduce commissioning time of proportional valves through onsite/pre-set tuning. [Proportional ▶ p10](#)
- Improve pneumatic system performance to avoid premature valve failures. [Preparation ▶ p12](#)
- Minimise air treatment equipment installation and maintenance time. [Preparation ▶ p12](#)

Finishing process

- Ensure precise linear motion and positional accuracy of transfers on uniformity machine. [Linear ▶ p8](#)
- Increase test equipment machinery reliability using robust pneumatic actuators. [Linear ▶ p8](#)

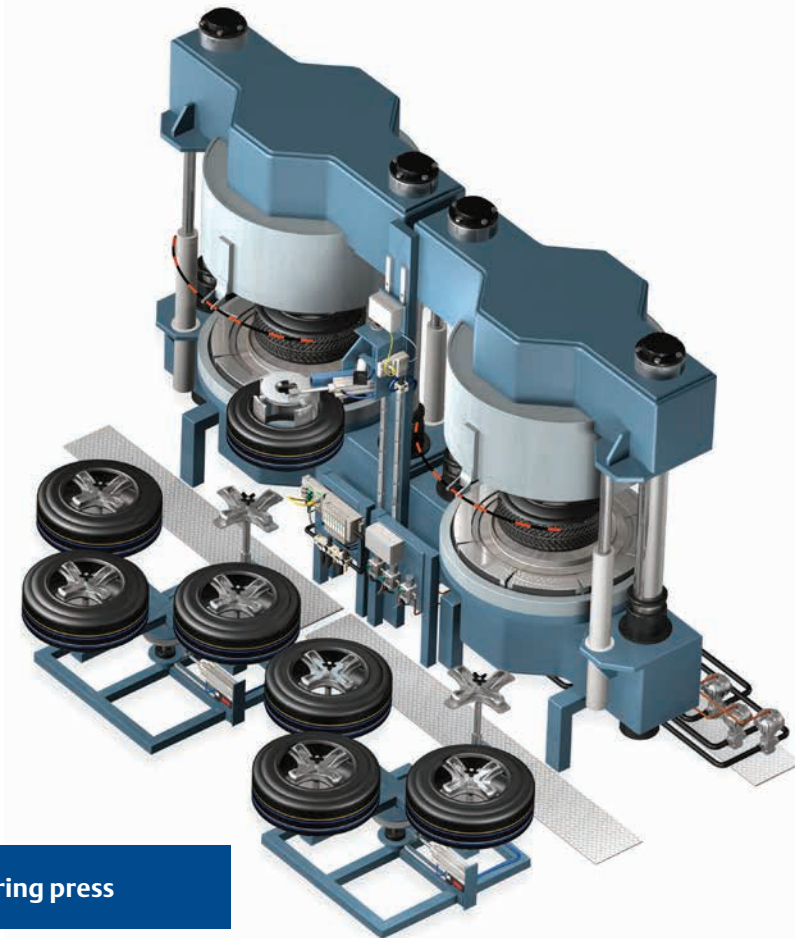

Pneumatic directional control

Repeatable, high precision directional control ensures your production meets the highest quality specifications every time. Using modular and compact valve islands you can achieve greater application flexibility, reduce costs, simplify commissioning and maximise availability of tyre building machinery. [Learn more. ▶ p6](#)

Linear motion control

Using robust and reliable cylinders and actuators to provide the precise linear motion and positional accuracy demanded of your application you can reduce lifecycle costs and maximise the uptime of machinery. [Learn more. ▶ p8](#)

Steam and fluid flow control

Durable pressure operated valves provide reliable control in challenging applications such as the mixing area and curing press. Flow control devices offering long, reliable lives and easy maintenance help you maximise production uptime and throughput. [Learn more. ▶ p10](#)

Air preparation and filtration

Improving plant pneumatic performance helps to avoid premature valve failures that increase maintenance costs and downtime. Modular air preparation technology enables simple assembly and maintenance for quicker start-up of machinery and safety applications. [Learn more. ▶ p12](#)

Pneumatic directional control

Pneumatic directional control valves are critical to the safe, efficient and precise operation of your wire and fabric calendars, extruders, tyre building machines, curing presses and finishing process. They control the pneumatics in your application, such as pressure operated steam valves, cylinders, actuators and other components. Robust and reliable valves ensure your machinery remains online 24/7, helping you to achieve throughput targets. Modular solutions provide flexibility to support machinery reconfigurations and allow fast replacement of modules should a critical failure occur. At the same time, the graphical display, advanced diagnostics and digital communications provided by Emerson's electronic valve islands, helps you to easily commission valves and subsequently identify issues quickly – all contributing towards greater uptime.

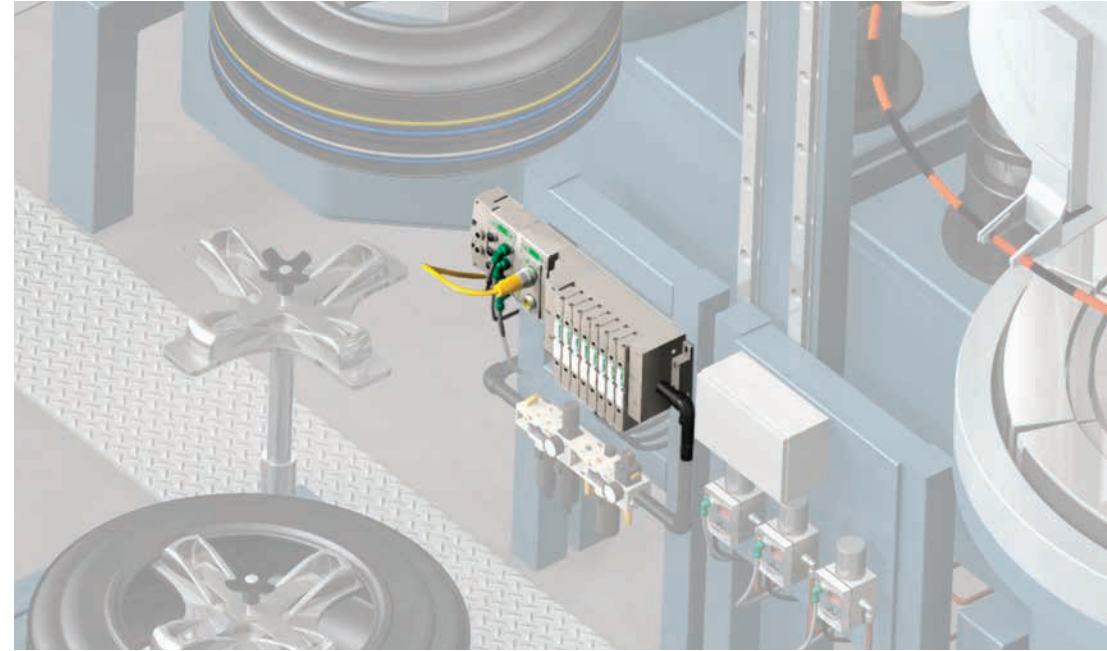

What's your opportunity?

- Cost-effectively network your valves to your control system using a choice of industrial communication protocols
- Quickly and safely replace a failed valve without the need to shut down complete machines or processes

Save time and cost, reduce overall footprint. Preassembled valve systems.

Complete preassembled, certified and ready-to-install pneumatic valve solutions can ensure your production start-up date is unaffected by any time and resource constraints. Emerson's experienced design engineers can help.



Services offered...

- Intuitive online product configurator tool simplifies the design of valve packages
- Availability of downloadable CAD files
- Quick shipping of components to meet tight commissioning schedules

Featured pneumatic directional control solutions

Pneumatic valve islands



- Compact modular valve islands that provide flexible and precise directional control from a vast array of valves for every application.
- Choice of electronics platforms that provide digital connectivity and diagnostic capability
 - Flexible modular system with innovative clip design allowing easy module removal and replacement
 - Valve islands designed to ISO 5599 and 15407 standards
 - 24V DC and air pilot zoning for machine safety integration
 - Interfaces to a broad range of valves

G3 and 580 Electronics platforms

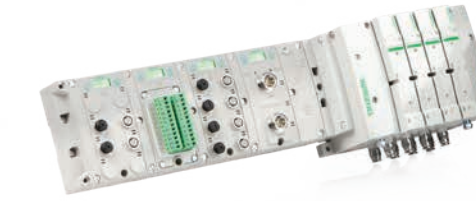

DeviceNet EtherNet/IP Modbus PROFINET
POWERLINK EtherCAT CANopen CC-Link IE IO-Link

- Digital electronics and I/O platforms that create highly distributed valve solutions that help reduce total cost of ownership.
- Unique graphic display provides diagnostic and status information for faster maintenance and commissioning
 - Auto recovery module protects configuration during a critical failure
 - Industry 4.0 capability
 - Connectivity using a range of industrial communication protocols

Directional control valves

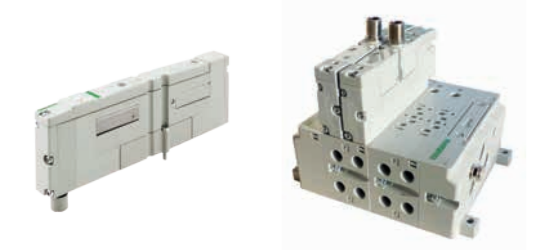

- A range of highly reliable and compact modular valves.
- Highest flow capability for product size enabling footprint reduction and lower costs
 - Lightweight and compact valves provide high performance and low energy consumption
 - Extremely reliable, with extended lifespans
 - Our valves comply with ISO Standards 15407-1 and 15407-2

Related products

Modular options



- A range of sandwich components that include pressure regulators, pressure shut-off, exhaust flow control and speed control.
- Compact design and reduces piping
 - Integrated safety function, different pressure/electrical zone and flexibility
 - Save energy with the pressure regulator. Reduce pressure to the right value you require
 - More flexibility by aggregating the main pneumatic functions on the valve island

Zoned safety valve islands



- The zoned safety capabilities of the ASCO Numatics valve islands enable the isolation of up to 3 safety zones on a machine, from one single island.
- Improve plant productivity. The island only isolates power to the group of valves in the operator's vicinity, meaning the whole system need not be re-pressurised on start-up
 - Reduce cost and complexity, as fewer components are required to reach the desired machine safety level
 - Conforms to the Machinery Safety Directive 2006/42/EC and complies with ISO 13849-1 and the NF EN 16474 standard
 - Evaluated by TÜV Rheinland

Linear motion control

Throughout the tyre manufacturing process, pneumatic cylinders provide precise and reliable motion control and positional accuracy. By offering greater repeatability and reliability, these devices reduce machinery downtime and maximise throughput. Meeting this requirement, Emerson's ISO and NFPA-conforming actuators and linear-guided cylinders are extremely durable, providing greater reliability and extended lifespans. By standardising on products from a single supplier, this simplifies your procurement process and reduces inventory and maintenance costs. Emerson offers the widest range of cylinders and actuators, suitable for installation everywhere from tyre building machines to the testing bed, helping to reduce your total cost of ownership.

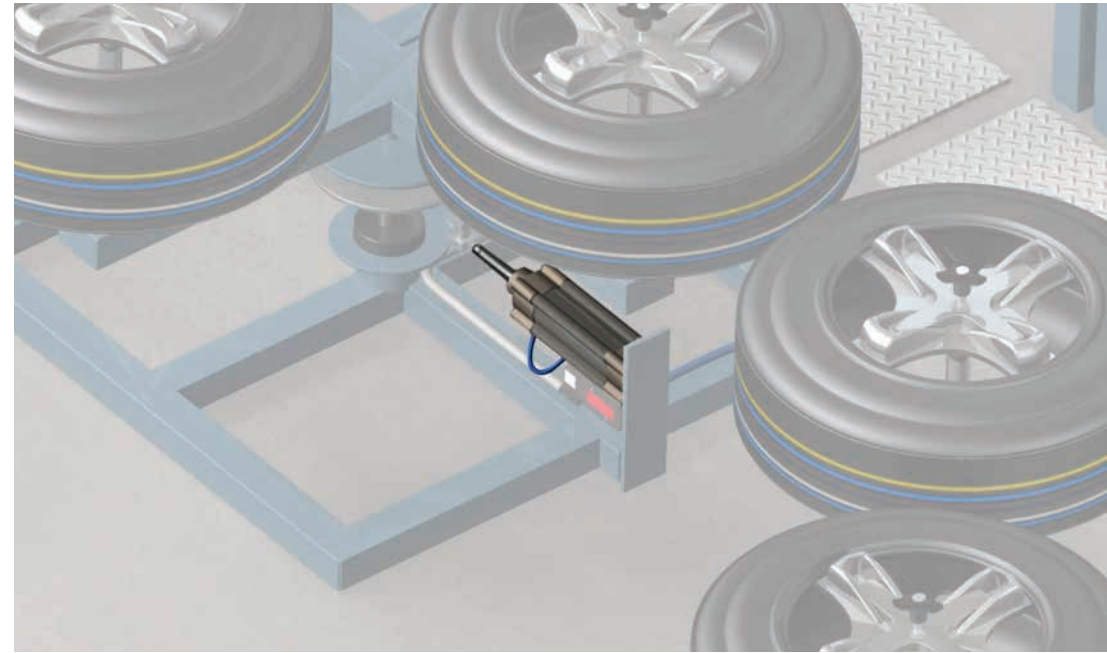

What's your opportunity?

- Reduce total cost of ownership by specifying robust and highly reliable actuators for your demanding applications



Engineered products. Designed to meet your application needs.

Despite offering a portfolio of over 50,000 products, we recognise that your application may demand a product that meets specific function or performance challenges. Emerson can customise products to suit your design requirements.



Services offered...

- Technology and application support delivered by experienced global representatives
- Rapid product repair and replacement service

Featured linear motion control solutions

Pneumatic cylinders and actuators



Robust and extremely durable pneumatic actuators and cylinders that provide linear or straight-line motion and force to your specific design requirements.

- Widest range of cylinders, many designed to CNOMO and ISO standards, including ISO 6431, ISO 6432, ISO 21287 and ISO 15552
- Extremely robust and durable devices that provide extended lifespans
- Suitable for systems of up to 17bar (250psi)

ASCO Numatics Series 450 cylinders



Durable tie rod air cylinder line delivers high accuracy performance and is designed to meet ISO 15552 requirements.

- Competitive interchangeability with ISO 15552 standard cylinders
- Extensive range of accessories allowing easy installation for virtually every application
- Durable design allows maximum productivity with low friction
- Easy maintenance – no lubrication required

ASCO Numatics Series A cylinders



Aluminium interchangeable air cylinder line designed and built to excel in the most demanding industrial applications meeting NFPA standard.

- Oversized wear band delivers 25% longer life
- Easy to mount and equipped for magnetic position detectors
- Self-lubricating, minimal maintenance

Related products

ASCO Numatics Series SH Linear Slides

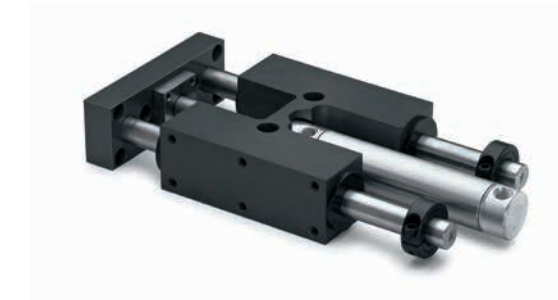

The Series SH guided linear motion device is capable of handling heavy loads and moderately long strokes.

- Double acting device that offers competitive interchangeability with heavy duty slides
- Simple mounting
- End of stroke adjustment options and sensing detection available

Cylinder with positioner for dosing control



Ready-to-install solution that enables you to precisely control the dosing on your application. We design and build a solution to the requirements of your application, whether that is a simple "on/off" cylinder and solenoid valve assembly, or a fully engineered, tested and certified linear actuator position system including Emergency Shutdown with control panels.



Steam and fluid flow control

Flow control devices, such as pressure operated valves, play an essential role in optimising the mixing process and ensuring efficient operation of the curing press. Emerson's durable pressure operated valves are designed to function in demanding steam applications and provide reliable and precise control, enabling rapid cycling and tight shut-off to ensure the curing press operates correctly and efficiently. This helps to minimise energy usage and reduce operating costs. The mixing process requires tight control of ingredients and process temperatures. Using Emerson piston valves, suitable for high pressure steam applications, you can ensure tyre materials meet your exact quality standards.

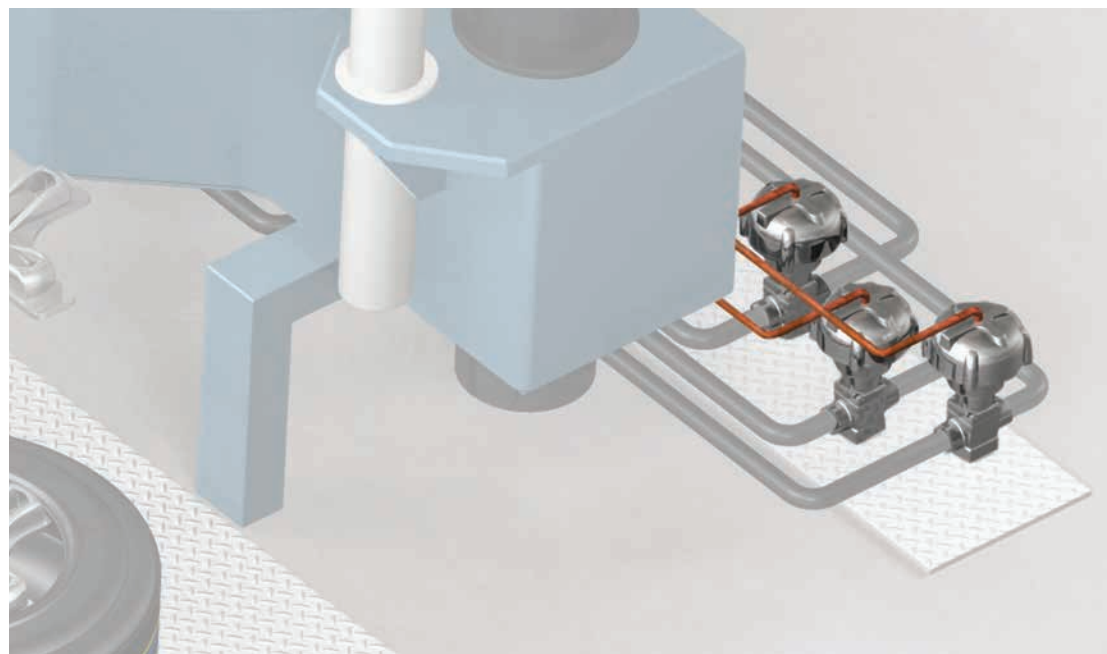

What's your opportunity?

- Reduce energy use by controlling steam with greater precision, helping to lower operational costs
- Reduce your total cost of ownership and maximise uptime by specifying valves offering long, reliable lives and easy maintenance

Correct valve selection and sizing to meet application demands.

Almost every application is different. It is important to specify the correct valve type, size and performance capability. Emerson experts can provide appropriate advice to ensure your application operates correctly helping you achieve on-time start-up.



Services offered...

- Global customer service available to discuss your application and appropriate valve solutions
- Local language support and advice
- Pressure operated valve repair services

Featured gas and fluid flow control solutions

ASCO Series 298 Valve



Rugged 2-way fluid piston valve, built to withstand steam, superheated water and corrosive fluids making it ideal for curing press applications.

- Superior durability and longevity
- High performance, maintenance free and resistance to shock and vibration (5G)
- Anti-water hammer design
- Ideal for use with steam: max fluid temperature of 250°C (482°F)
- Max ambient temperature of 180°C (356°F)
- Proportional versions available

Integrated ASCO Series 298 solutions



- We have the expertise to engineer ASCO Series 298 solutions, such as a compact manifold solution and Series 298 with positioning
- Delivered fully engineered and tested, ready-to-install

Valve repair service



A valve repair service is available for our ASCO Series 298 pressure operated valves, which can save you up to 50% of the cost of a new valve. Contact your local sales office for more information.

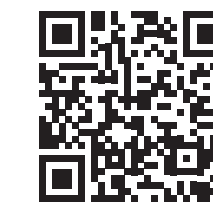

Watch the ASCO Valve Repair video.

Related products

ASCO Series 290 Valve



2-way direct acting valve designed for demanding applications involving aggressive and high temperature liquids, gases and steam.

- High flow, extremely durable and easy maintenance
- Proven reliability over 2 million cycles
- Provides variable flow proportional to the control signal
- Fail close construction. Closes upon loss of power enhancing safety
- Position feedback to help optimise flow

ASCO Numatics proportional valves



Our wide range of proportional valves with digital control provide precisely tuned, cost-effective air pressure to the tyre plant.

- Field programmable on the tyre line providing application flexibility
- Closed loop pressure control maximises production processes
- Valve control loop parameters can be optimised for specific applications

ASCO solenoid valves

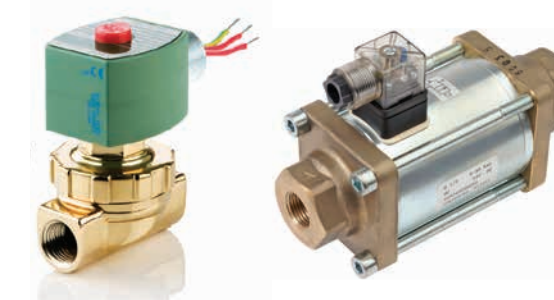

Versatile and well-proven general service solenoid valves are suitable to control flow of air, gas, liquids and steam and ideal for mixing area applications.

- World's largest selection of 2-way, 3-way and 4-way solenoid valves enabling standardisation from single supplier
- Provides long life even in demanding applications
- Power management technology reduces energy consumption

Air preparation and filtration

If compressed air supply to the pneumatic system is not filtered and pressure regulated, machinery will not function correctly and valves may fail prematurely. Air preparation using Emerson's filter, regulator and lubrication (FRL) solutions ensures that machinery operates correctly, maintenance is reduced, and production throughput can be maximised. By adopting a modular FRL solution, individual parts of the FRL can be quickly replaced to meet changing system demands that may be required when a new manufacturing line is introduced. This provides the user with greater flexibility and supports faster commissioning and maintenance.

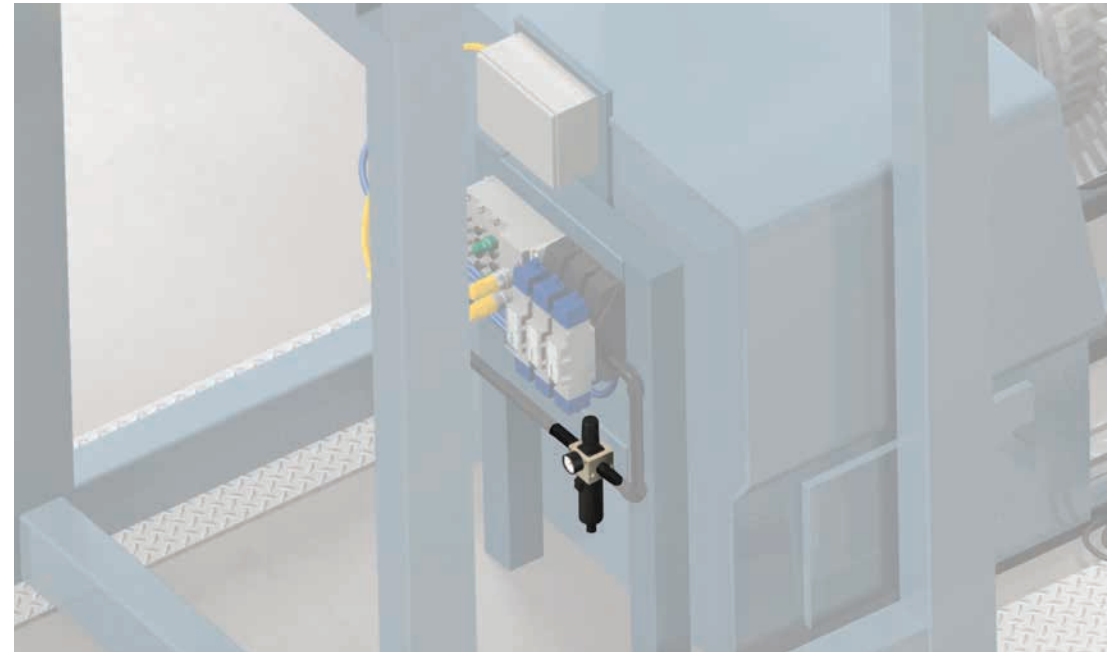

What's your opportunity?

- Greatly increase the lifespan of valves by purifying compressed air and regulating pressure
- Confidently increase the safety of your workers by locking systems down during maintenance



Enhance pneumatic system performance and safety. Discuss your application with Emerson experts.

The safety of your workers and equipment is paramount. Compressed air systems must be designed, installed and maintained correctly to ensure continued performance and safety during operation and maintenance. Emerson application experts can provide advice on implementing the appropriate technology to prevent safety incidents.



Services offered...

- Complete air preparation design
- Online configuration tool
- Downloadable CAD drawings

Featured air preparation and filtration solutions

ASCO Numatics Series 651, 652 and 653 Modular Air Preparation



Modular filter, regulator, lubrication device that prepares and regulates compressed air to ensure optimum performance of pneumatic systems.

- Modular format supports fast assembly and maintenance
- Multi filtration options (particulate, coalescing and absorbing)
- Extended operating temperatures range supporting installations anywhere in the tyre plant
- Shut-off isolation valve for safety applications

Slow-start, Quick Exhaust and Shut-off Isolation valves



- Robust and easy to operator shut-off valve with lockout handle
- Solenoid or air piloted exhaust valves
- High exhaust capacity for quick depletion of downstream pressure
- Slow-start valves provide gradual increase of pressure

Featured air preparation and filtration solutions

Filters



Broad range of particulate, coalescing and adsorbing filtration options to remove particulate and water droplets from compressed air or insert gas.

- Particulate elements include 5, 25 and 40 micron
- Coalescing filter elements to remove oil and sub-micron particles down to 0.01 microns
- Visual or electrical differential pressure indicators for condition monitoring of filter element

Lubricators



A range of lubricator modules that provides consistent and reliable lubrication to the compressed air system.

- Optional electronic liquid level indicator for condition monitoring

Regulators



A range of regulator modules that maintain optimum pressure of compressed air systems throughout the plant.

- High flow with a wide range of adjustable output pressure ranges
- Flows in excess of 2050 L/min (72 SCFM)
- Relieving, non-relieving and manifold regulators

ASCO Numatics VL/VT lockout valves



Preventing unauthorised pressurisation of an air system during service or maintenance, these lockout valves ensure the safety of workers and equipment.

- Emergency shut-off allows exhaust of downstream pressure
- Slo-Start™ feature allows downstream pressure to gradually increase
- Robust, reliable and meets OSHA specifications

Reduce time, cost and risk with Emerson's integrated solutions

When timelines are short and resources at a premium, this can increase the risk of a project being delivered late and over budget. To meet this challenge, Emerson can design, build, test, certify and install your fluid automation technology and systems. Preassembled, ready-to-install integrated assemblies, panels and cabinets, specifically built to your specification help lower the risk of design amends during the production phase, reduce equipment footprints, simplify integration with other systems and offer reductions in assembly, R&D and procurement costs.

Integrated assemblies

- Pneumatic cylinder, air preparation and solenoid valve assemblies
- Fully engineered linear actuator position systems
- Fully tested and ready to install

Panel mount solutions

- Compact ready-to-install solutions
- Components certified to meet requirements of application
- Customised solutions to your needs

Cabinet solutions

- Fully tested and certified turnkey solutions
- Reduced interfaces, gateways, components and wiring
- Simplified architecture, less design and engineering work



Using our extensive design and engineering expertise, you can meet tighter timescales and reduce project start-up times. Contact us today!

Get started



Emerson delivers time-tested and innovative fluid automation solutions designed to help you improve your operation's overall uptime, performance and flexibility. Contact us now for world-class technologies, and services that can maximise your throughput, lower your cost of ownership and support your product innovations. Getting started is easy. Visit [Emerson.com/tires](https://www.emerson.com/tires)

**Emerson Automation Solutions
United Kingdom**
Pit Hey Place, West Pimbo
Skelmersdale, Lancashire, WN8 9PG
T +44 (0)1695 71 36 00
E enquiries.asco.uk@emerson.com

**Emerson Automation Solutions
ASCO SAS – France**
53 Rue de la Beauce
28111 Lucé
T +33 (0)2 37 24 47 72
E anf.serviceclients@emerson.com

**Emerson Automation Solutions
ASCO Valve Inc. – United States**
160 Park Avenue,
Florham Park, NJ, 07932
T +1 (0)800-972-2726
E info-valve@asco.com

**Emerson Automation Solutions
ASCO ASIA – Singapore**
Blk 4008, Ang Mo Kio Avenue 10
#4-17/22, TECHplace 1
Singapore 569625
T +65 6556 1100
E valvesales@emerson.com

The Emerson logo is a trademark and service mark of Emerson Electric Co. Brand logotype are registered trademarks of one of the Emerson family of companies. All other marks are the property of their respective owners. © 2018 Emerson Electric Co. All rights reserved.



CONSIDER IT SOLVED™