

APPLICATION

For Assembling Type 1278M Series Flush Mounting Ring

Used to flush mount gauge case Type 1279(*)S and 1379(*)S. Standard finish is black; polished stainless steel finish is available at an extra charge.

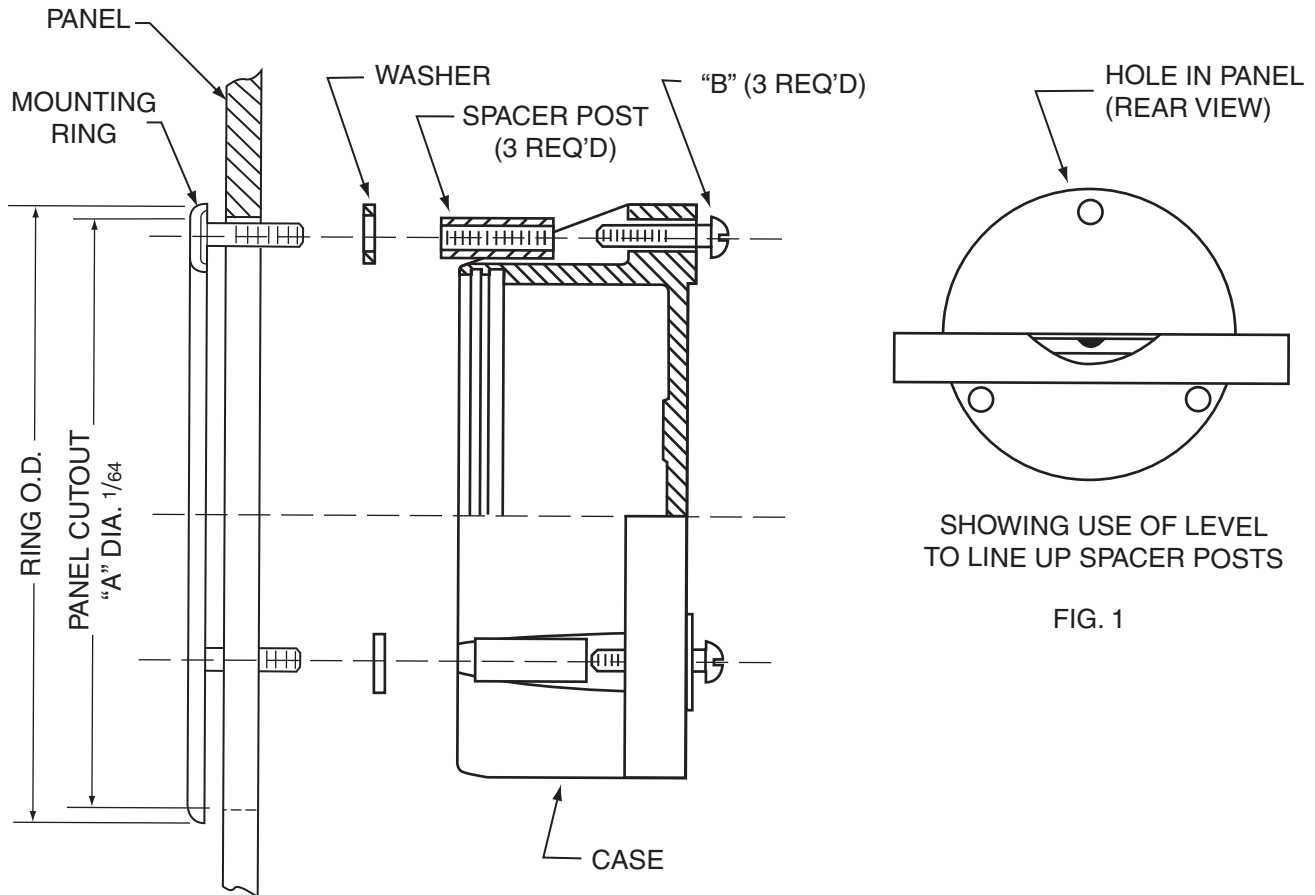

FIG. 1

INSTRUCTIONS

1. Cut hole in panel to "A" diameter.
2. Apply mounting ring from front side of panel so that the ring studs enter panel hole.
3. Assemble washers as required by panel thickness, i.e., no washers for 5/16" panel, one washer for 1/4" panel, two washers for 3/16" panel, and three washers for 1/8" panel.
4. Assemble three spacer posts just loose enough to permit rotation of ring in panel.
5. Lay a level across two lower spacer posts and rotate ring as necessary to bring posts to a horizontal line (see Fig. 1).
6. Tighten all spacer posts.
7. Assemble case to spacer posts with three screws.

CASE DIMENSIONS

GAUGE SIZE	RING O.D.	"A" DIA.	"B" Size of 3 Screws	"C" Size of Washers
4½	6.000 (152)	5 5/8 (148)	#10-24 x 1 5/8	7/16 x 1 7/64 x 5/8
6	7.765 (197)	7 3/4 (189)	¼ x 20 x 1 ½	7/16 x 1 7/64 x 5/8