



Safe Motion Control

SAFE MOVEMENT MONITORING

SICK
Sensor Intelligence.

SAFE MOTION CONTROL – SAFE MOVEMENT MONITORING

The constant development of higher and higher-performance machines inevitably entails a call for greater protection of people, machines and systems.

Innovative machines and safety concepts mean that the availability and efficiency of machines can be increased whilst still offering entirely unencumbered safety. This is where Safe Motion Control comes to the fore. Safe Motion Control describes drive safety monitoring using products from the Motion Control and Motion Control Sensors departments.

Due to the safe monitoring of the machine operator, as well as the machine parameters (speed, path, and acceleration), it is possible to differentiate precisely between hazardous and safe machine movements. This allows a machine to be controlled while a process is running without interruption to the process, minimizing of downtimes, and an increase in the efficiency of machines and systems.

With Safe Motion Control from SICK, you can play it safe.

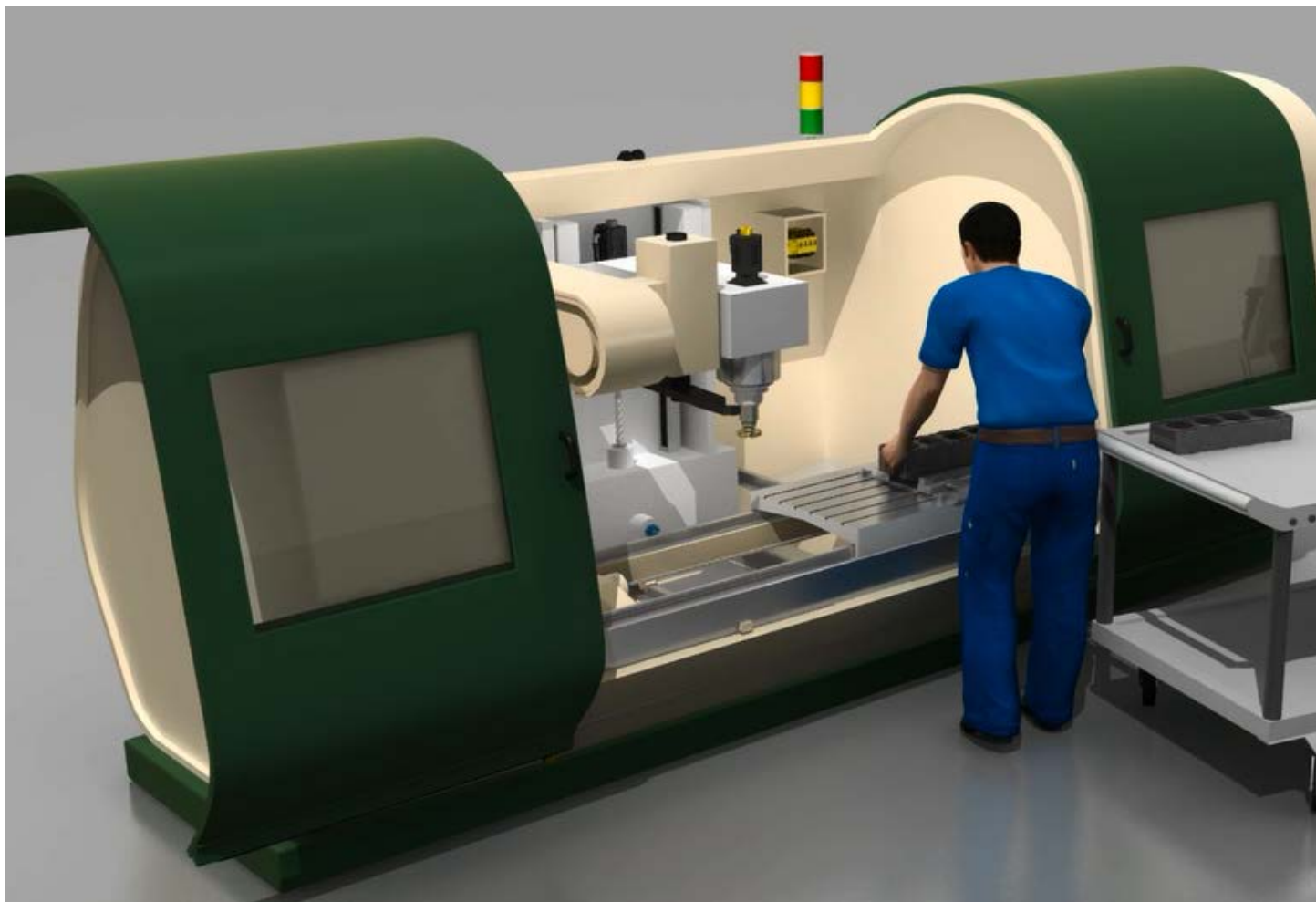

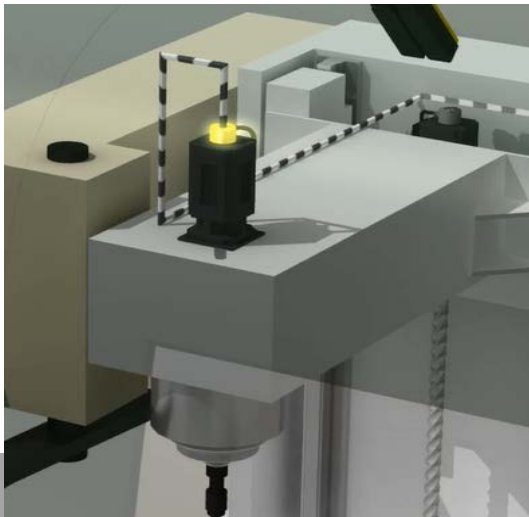

Safe Motion Control	4
Safety encoder	11
Motor feedback systems	12
Safety controllers	16
Example application.....	21

SAFE MOTION CONTROL



Play it safe with SICK

Safe motion monitoring can be implemented in a variety of ways depending on the safety concept or the control concept. In principle, there is a differentiation between integrated and external safety concepts:

We offer the right solution for implementing both, in motion control sensors such as safety encoders, and safe motor feedback systems, as well as the Flexi Soft safety controller.

Complete solutions from a single source

SICK offers you complete solutions from a single source: Products, services and extensive knowledge on all matters relating to safety.

Cost benefit

Selecting suitable SICK safety technology components can also be beneficial from a financial perspective, due for example, to decreased implementation and assembly costs.

Increased productivity

Thanks to innovative safety technology concepts, Safe Motion Control allows you to monitor the movement of a machine at any time. All signals of the safety sensors and actuators can be combined, and the information can be used to determine whether there is an actual risk for the machine operator when accessing the hazardous area. This means that unintended shutdowns are avoided, cycle times are reduced, availability is increased and productivity is raised.

Verification and certification

Safety products from SICK have already been certified by external bodies. This simplifies the system certification process.

SERVICE



Global service



EXPERTISE



Expertise in functional safety

This is what makes SICK stand out:

- SICK is a professional partner at your side, backed up by many years of experience in safety and drive technology
- Offering a diverse range of Safe Motion Control solutions due to wide product portfolio
- Global sales and service network
- Complete solutions from a single source

→ www.sick-safetyplus.com

SAFE MOTION CONTROL: ALWAYS THE RIGHT SAFETY CONCEPT FOR ANY APPLICATION

EXTERNAL SAFETY CONCEPT

COMPONENTS OF THE DRIVE SYSTEM:

- Digital servo drive without safety function
- Motor feedback system or encoder, available as a variant for standard applications or safety applications
- External safety monitor

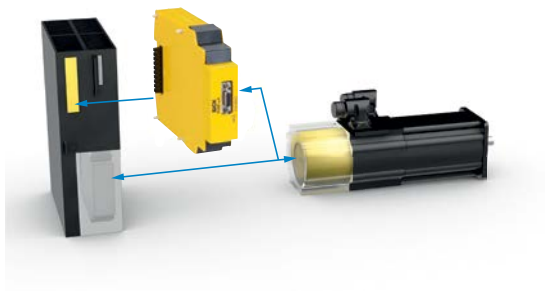

THE SICK SOLUTION:

- Motor feedback system with HIPERFACE® or encoder such as SRM50S or DFS60S Pro
- Drive Monitor FX3-MOCO



DFS60S Pro



Drive Monitor FX3-MOCO



SRM50S



TYPICAL APPLICATIONS:

- Retrofitting of existing drive systems
- Automated guided transport systems
- Storage and conveying technology
- Machine building
- Handling systems
- Machine tools, servo presses

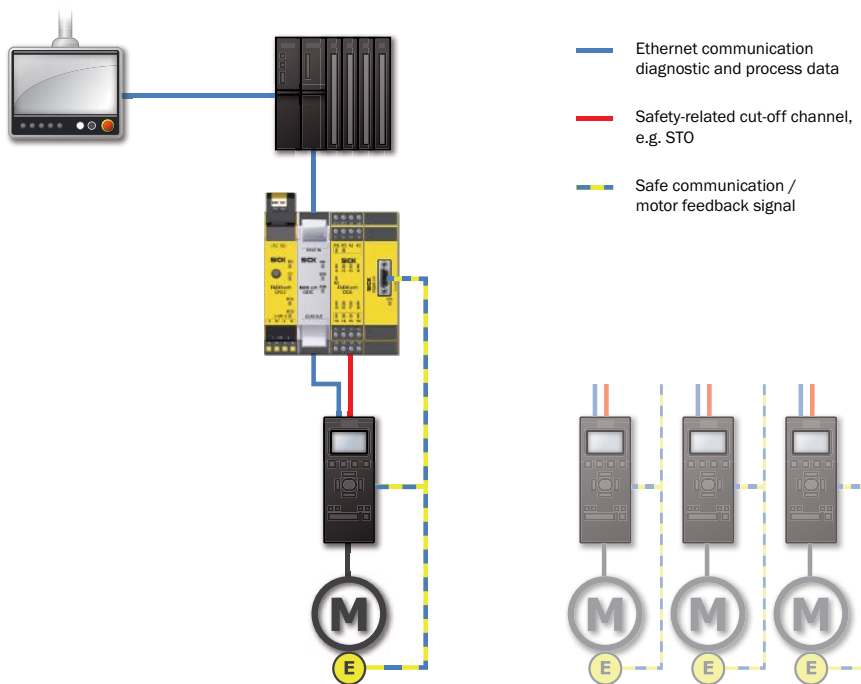

ADVANTAGES OF THE EXTERNAL SAFETY CONCEPT:

- High protection from manipulations thanks to separation of safety and automation tools
- The external safety concept is independent of the drive system
 - High flexibility in the drive selection:
 - Focus can be placed on machine parameters, customer requirements and budget
 - Easy retrofitting of existing machines
 - Scalable safety and machine concept
- All safety solutions in one software save time and money
 - Fast creation of configurations
 - Faster software adjustments for changing requirements
 - Fast and easy validation and verification, thanks to an automatically generated report
- Monitoring multiple drives in a system
 - Dependencies between the movements of individual drives can be taken into account
 - Even complex applications can be implemented
- Our verified and industry-specific application packages relieve you of engineering efforts
 - Components coordinated to each other
 - Prepared application software and calculation examples
 - Detailed application descriptions

SAFE MOTION CONTROL: ALWAYS THE RIGHT SAFETY CONCEPT FOR ANY APPLICATION

INTEGRATED SAFETY CONCEPT

COMPONENTS OF THE DRIVE SYSTEM:

- Digital servo drive with integrated safety function
- Servomotor with safe motor feedback system

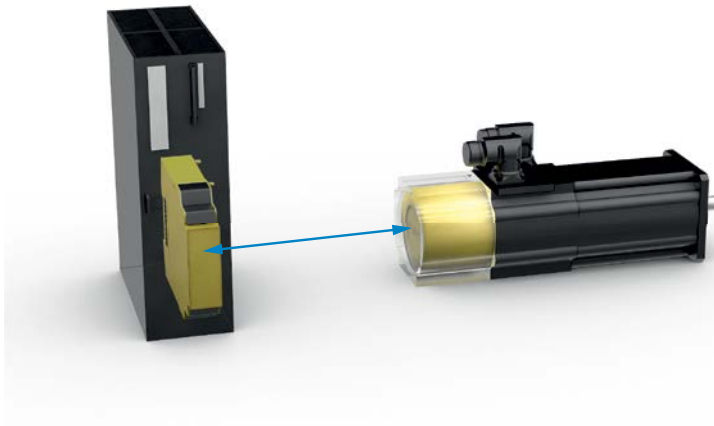

- Safe motor feedback system with HIPERFACE® or HIPERFACE DSL® such as SRM50S or EKM36-2



Motor feedback systems EKM36-2



TYPICAL APPLICATIONS:

- Packaging systems
- Metalworking machines
- Handling systems

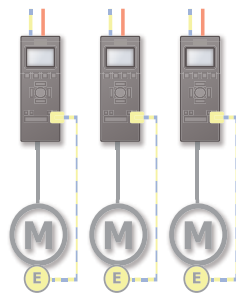
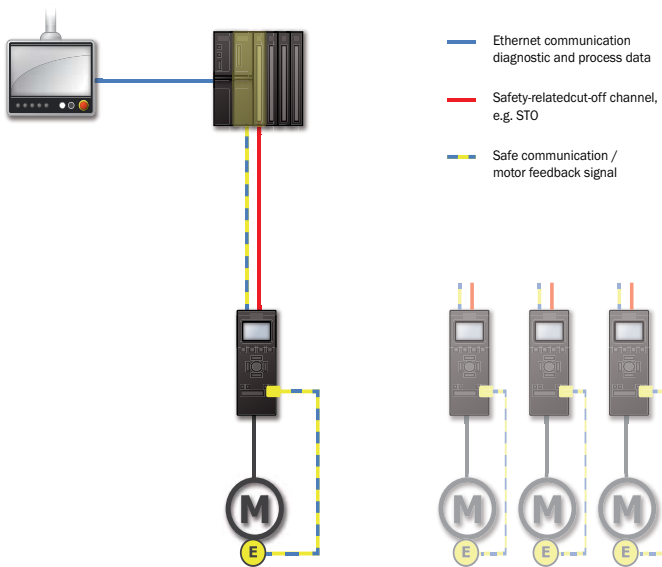

ADVANTAGES OF THE INTEGRATED SAFETY CONCEPT:

- Only a few male connectors and cables are required
- Fewer components
- Complete drive system from one manufacturer
- Quick certification
- Short response time for errors
- Easy availability of the control parameters

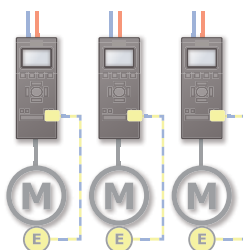
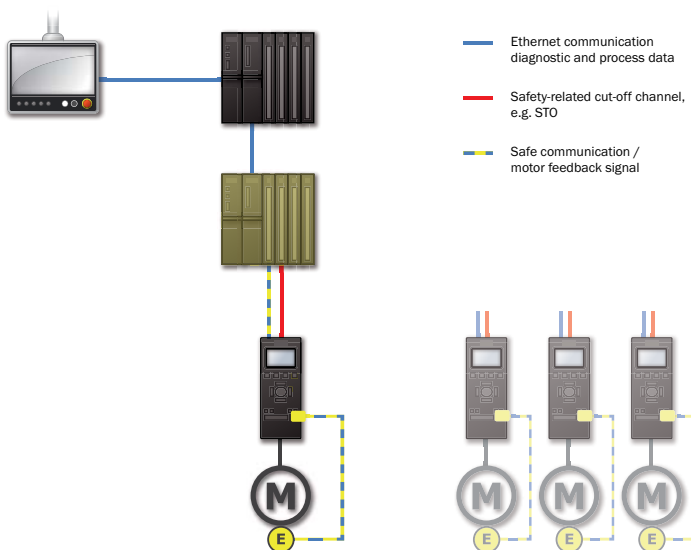

DRIVE FUNCTIONS ACCORDING TO IEC 61800-5-2

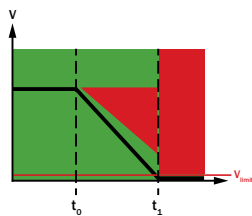

Safe stop 1 (SS1)

- Corresponds to stop category 1 as per EN 60204-1
- Controlled shutdown maintaining the power supply to the drive elements
- The ramp is monitored
- After shutting down or below a speed limit: Activation of the safe torque off (STO) function

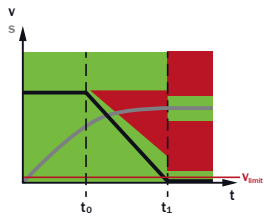

Safe stop 2 (SS2)

- Corresponds to stop category 2 as per EN 60204-1
- Controlled shutdown maintaining the power supply to the drive elements
- The ramp is monitored.
- After shutting down: Safe monitoring of the drive shaft position in a defined range

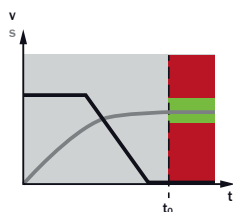

Safe operating stop (SOS)

- After shutting down: Safe monitoring of the drive shaft position in a defined range

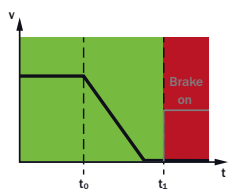

Safe brake control (SBC)

- The safe brake control (SBC) function provides safe output signals for controlling external brakes

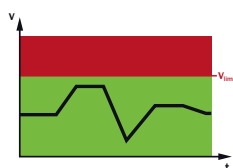

Safely limited speed (SLS)

- When permission has been given, a safe, reduced speed is monitored in the special mode
- If the speed is exceeded then one of the safe stop functions is triggered

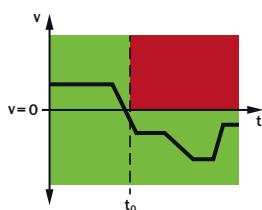

Safe direction (SDI)

- In addition to safe movement, there is also monitoring of safe direction of rotation (right/left)
- In the event of movement in an unapproved direction of rotation, a safe stop function is triggered



At a glance

- Encoders for functional safety technology: SIL2 (IEC 61508), SILCL2 (EN 62061), PLd (EN ISO 13849)
- Electrical interface: 4.5 V ... 32 V, sine/cosine 1 VPP, 1,024 periods
- Clamping flange or servo flange, blind hollow shaft or through hollow shaft (assembly options with feather key)
- Universal cable outlet, M23 or M12 male connector, axial or radial
- Enclosure rating: IP 65
- Working temperature range: -30 °C ... +95 °C (depending on type)

Your benefits

- Certified safety solution that ensures the best possible protection for persons, machinery, and systems
- Easy and practical implementation of safety functions using an all-in-one solution, safety functions with the Flexi Soft Drive monitor by SICK: safe stop 1 (SS1), safe stop 2 (SS2), safe operating stop (SOS), safe speed monitoring (SSM), safely limited speed (SLS), safe direction (SDI), safe brake control (SBC)
- Force fit and tight fit for mechanical reliability
- Certified safety products reduce the scope of safety engineering
- Versatile connection options for high levels of flexibility and straightforward implementation
- Compact size for compatibility with applications in which installation space is limited

Ordering information

Additional device versions

Mechanical design	Shaft diameter	Connection type	Model name	Part no.
Solid shaft with feather key, servo flange	6 mm	Male connector M12, 8-pin, radial	DFS60S-SDOC01024	1069524
Solid shaft with feather key, face mount flange	10 mm	M23 male connector, 12-pin, radial	DFS60S-SEOA01024	1069521
		Cable, 8-wire, universal, 1.5 m	DFS60S-SEOK01024	1067913
Blind hollow shaft with feather key groove	10 mm	Male connector M12, 8-pin, radial	DFS60S-BDOC01024	1067915
	14 mm	M23 male connector, 12-pin, radial	DFS60S-BGOA01024	1069540
Through hollow shaft	10 mm	Male connector M12, 8-pin, radial	DFS60S-TDOC01024	1069527
	12 mm	Cable, 8-wire, universal, 1.5 m	DFS60S-TEOK01024	1069530



At a glance

- Motor feedback systems for the top power range
- 1,024 sine/ cosine periods per revolution
- Absolute position with a resolution of 32,768 increments per revolution and 4,096 revolutions with the multiturn system
- HIPERFACE® interface: Programming of the position value and electronic type label
- Plug-in shaft or tapered shaft with various stator couplings
- Installation, mounted or standalone versions
- Certified according to SIL2/PL d (only valid for SRS50S/SRM50S...)
- RoHS-compliant

Your benefits

- Motor feedback systems with HIPERFACE® interface
- High shock/vibration resistance thanks to built-in metal code disk
- Consistent motor design due to identical size of single and multiturn versions
- Through the use of a certified SIL2 / PL d motor feedback system certification according to EN ISO13849 is possible
- Very smooth running thanks to maximum ball bearing distance

→ www.mysick.com/en/SRS_SRM50

For more information, simply enter the link or scan the QR code and get direct access to technical data, CAD design models, operating instructions, software, application examples, and much more.



Ordering information

Other device versions www.mysick.com/en/SRS_SRM50

Design	Mechanical design	Connection type	Model name	Part no.
Singleturn, 2048 EEPROM	Tapered shaft, spring mounting plate	Male connector	SRS50S-HFA0-K22	1051790
Singleturn, 2048 EEPROM	Tapered shaft, spring mounting plate	Stranded cable	SRS50S-HFV0-K22	1051792
Multiturn, 2048 EEPROM	Tapered shaft, spring mounting plate	Male connector	SRM50S-HFA0-K22	1051794
Multiturn, 2048 EEPROM	Tapered shaft, spring mounting plate	Stranded cable	SRM50S-HFV0-K22	1051796



At a glance

- Motor feedback system with HIPERFACE DSL® interface
- Compact, rugged design with 50 mm diameter
- Up to 23-bit resolution per revolution and 4,096 revolutions measurable with the multiturn system
- Facility for connecting an external temperature sensor
- E²Prom with 8 KB of free memory space
- SIL2-certified (only valid for EFS/EFM50-2)
- 12-bit resolution of the safe position value
- Service life histogram

Your benefits

- Thanks to data transmission exclusively in digital format, no analog components are necessary on the controller side
- The absence of a separate encoder cable considerably reduces costs. Data transmission is synchronized with the controller cycle.
- Minimum cabling thanks to integration of encoder communication into the motor cable
- Optimization of the controller circuit via automatic synchronization with the controller cycle

→ www.mysick.com/en/EFS_EFM50

For more information, simply enter the link or scan the QR code and get direct access to technical data, CAD design models, operating instructions, software, application examples, and much more.



Ordering information

Additional device versions

Model	Torque support	Type	Part no.
Singleturn, HIPERFACE DSL®	Spring mounting plate	EFS50-0KF0A021A	1073485
		EFS50-0KF0A023A	1073501
		EFS50-2KF0A021A	1073487
		EFS50-2KF0A023A	1073503
Multiturn, HIPERFACE DSL®	Spring mounting plate	EFM50-0KF0A021A	1073486
		EFM50-0KF0A023A	1073502
		EFM50-2KF0A021A	1073488
		EFM50-2KF0A023A	1073504



At a glance

- Motor feedback system for the standard power range
- 128 sine/cosine periods per revolution
- Absolute position with a resolution of 4,096 increments per revolution and 4,096 revolutions with the multiturn system
- Programming of the position value and electronic type label
- HIPERFACE® interface
- Built-in and standalone designs
- Certified in accordance with SIL2/PL d (only applies to SKS36S/SKM36S-H...)
- RoHS-compliant

Your benefits

- Its small dimensions allow manufacturers of small and very small motors to achieve a significant reduction in the length of their motors
- The standalone version makes an ideal master or path encoder
- The SKS/SKM36 motor feedback systems boast high market penetration in the field of drive engineering
- Due to the uniform mechanical component, a high level of flexibility can be achieved with SEK/SEL37 when using with various encoder systems

→ www.mysick.com/en/SKS_SKM36

For more information, simply enter the link or scan the QR code and get direct access to technical data, CAD design models, operating instructions, software, application examples, and much more.



Ordering information

Other device versions www.mysick.com/en/SKS_SKM36

Design	Model name	Part no.
Singleturn, tapered shaft	SKS36S-HFA0-K02	1036556
Multiturn, tapered shaft	SKM36S-HFA0-K0	1036558



At a glance

- Motor feedback system with HIPERFACE DSL® interface
- Compact, rugged design with 36 mm diameter
- Up to 20 bit resolution per revolution and 4,096 revolutions measurable with the multiturn system
- Facility for connecting an external temperature sensor
- E²Prom with 8 KB of free memory space
- SIL2-certified (only applies to EKS/EKM36-2...)
- Service life histogram

Your benefits

- Saving all analog components on the controller part through exclusively digital data transmission
- Enormous cost saving thanks to the separate encoder cable no longer being necessary, data transmitted synchronously to the controller cycle
- Minimal cabling thanks to integration of the encoder communication into the motor cable
- Optimization of the controller circuit via automatic synchronization with the controller cycle

→ www.mysick.com/en/EKS_EKM36

For more information, simply enter the link or scan the QR code and get direct access to technical data, CAD design models, operating instructions, software, application examples, and much more.



Ordering information

Other device versions www.mysick.com/en/EKS_EKM36

Design	Resolution per revolution	Connection type	Model name	Part no.
Singleturn	18 Bit	Built into motor cable, 1 temperature sensor	EKS36-2KF0A018A	1054315
Singleturn	20 bit	Built into motor cable, 1 temperature sensor	EKS36-2KF0A020A	1054323
Multiturn	18 Bit	Built into motor cable, 1 temperature sensor	EKM36-2KF0A018A	1054316
Multiturn	20 bit	Built into motor cable, 1 temperature sensor	EKM36-2KF0A020A	1054324



At a glance

- Expansion modules, Motion Control modules, and gateways for all standard fieldbuses
- Configuration data stored in the system plug
- Reliable networking of up to 32 Flexi Soft stations
- Integration of sensor cascade
- Multi-language, license-free configuration software: exceptionally simple operation, plausibility check, simulation mode, wiring diagram, parts list, documentation, and data recorder

Your benefits

- Scalable for an efficient and cost-optimized safety application solution
- Cost savings: Flexi Soft can have a modular structure that is in line with your requirements, and thus offers an ideal level of granularity
- Intuitive configuration software featuring comprehensive functions enables continuous monitoring of the configuration
- Quick verification of the safety application:
- The configuration software provides documentation and a wiring diagram
- Safety logic is easy to configure thanks to ready-made, TÜV-certified function blocks
- The main module's diagnostics interfaces and the configuration storage facility in the system plug enable rapid commissioning, component replacement, and troubleshooting, resulting in minimum downtimes

→ www.mysick.com/en/Flexi_Soft

For more information, simply enter the link or scan the QR code and get direct access to technical data, CAD design models, operating instructions, software, application examples, and much more.



Ordering information

Other device versions www.mysick.com/en/Flexi_Soft

Main module

Number of EFI interfaces	Flexi Link	Automatic Configuration Recovery (ACR)	Flexi Line	Model name	Part no.
0	-	-	-	FX3-CPU000000	1043783
2	✓	-	-	FX3-CPU130002	1043784
		✓	-	FX3-CPU230002	1058999
		✓	✓	FX3-CPU320002	1059305

Gateways

Fieldbus, industrial network	Model name	Part no.
Ethernet/IP	FX0-GENT00000	1044072
TCP mode	FX0-GMOD00000	1044073
PROFINET	FX0-GPNT00000	1044074
EtherCAT	FX0-GETC00000	1051432
PROFIBUS DP	FX0-GPR000000	1044075
CANopen	FX0-GCAN00000	1044076
DeviceNet	FX0-GDEV00000	1044077

I/O modules

Flexi Loop compatible	Number of safe inputs	Number of non-safe inputs	Number of test signal outputs	Number of safe outputs	Number of non-safe outputs	Model name	Part no.
✓	8	0	2	4	0	FX3-XTI084002	1044125
			8	0	0	FX3-XTIDI80002	1044124
			2	0	4 ... 6	FX3-XTDS84002	1061777
-	0	6 ... 8	0	0	6 ... 8	FX3-STI068002	1061778

Relay modules

Number of enabling current paths	Number of signaling current paths	Number of check-back current paths	Model name	Part no.
2	1	1	UE410-2R04	6032677
4	2	2	UE410-4R04	6032676
2	0	1	UE10-2FG3D0	1043916
			UE12-2FG3D0	1043918



At a glance

- 7 drive safety functions: SS1, SS2, SOS, SSM, SLS, SDI and SBC
- For all common encoder interfaces
- Programmable logic

Your benefits

- Integration into a Flexi Soft system with a software tool and a project file allows quick project planning and commissioning
- Easy logic development using pre-defined, modifiable, freely configurable applications
- Maximum level of integration into higher-level controllers via all common fieldbus systems using gateway

- Monitoring of up to 10 speed levels and 4 brake ramps
- Possible to monitor multiple axes

- Documentation of the entire safety application simplifies machine acceptance and validation
- Monitoring movements instead of shutting down increases machine productivity
- Flexibility due to a wide range of drive safety functions



→ www.mysick.com/en/Flexi_Soft_Drive_Monitor

For more information, simply enter the link or scan the QR code and get direct access to technical data, CAD design models, operating instructions, software, application examples, and much more.



Ordering information

Other device versions www.mysick.com/en/Flexi_Soft_Drive_Monitor

Description	Model name	Part no.
Motion control module, Flexi Soft drive monitor	FX3-MOC00000	1062344



At a glance

- Standstill and speed monitoring
- 4 safe semiconductor outputs
- PL e (EN ISO 13849), SIL3 (IEC 61508), SILCL3 (EN 62061)
- Maximum input frequency of 2 kHz
- Adjustable speed limit/monitoring frequency of 0.1 to 9.9 Hz or 0.5 to 99 Hz, depending on the variant
- 2 application diagnostic outputs for failure and status display
- Diagnostic LEDs

Your benefits

- Easy commissioning using only a screwdriver – reduces installation time
- Tool backup using the Flexi Soft Designer and the Flexi Classic Configurator
- Additional HTL encoder evaluation
- Cascading of multiple axes possible

→ www.mysick.com/en/Speed_Monitor

For more information, simply enter the link or scan the QR code and get direct access to technical data, CAD design models, operating instructions, software, application examples, and much more.



Ordering information

Other device versions www.mysick.com/en/Speed_Monitor

Adjustable speed limit	Connection type	Model name	Part no.
0.1 Hz to 9.9 Hz	Screw terminals	MOC3SA-AAB43D31	6034245
	Spring terminals	MOC3SA-AAB44D31	6034246
0.5 Hz ... 99 Hz	Screw terminals	MOC3SA-BAB43D31	6034247
	Spring terminals	MOC3SA-BAB44D31	6034248



At a glance

- Standstill monitoring by means of residual voltage measurement
- 3 normally open and 1 normally closed positively guided safety contacts
- 2 application diagnostic outputs (semiconductor)
- 1 application diagnostic output (N/O)
- PL e (EN ISO 13849), SIL3 (IEC 61508), SILCL3 (EN 62061)
- Maximum motor supply voltage 690 V
- Adjustable voltage threshold and standstill period

Your benefits

- Quick mounting and installation since no additional wiring is required
- Easy commissioning using a screwdriver – reduces installation time
- Easy to retrofit as the subsequent mounting of sensors is not necessary

→ www.mysick.com/en/Standstill_Monitor

For more information, simply enter the link or scan the QR code and get direct access to technical data, CAD design models, operating instructions, software, application examples, and much more.



Ordering information

Other device versions www.mysick.com/en/Standstill_Monitor

Supply voltage	Connection type	Model name	Part no.
24 V DC	Screw terminals	MOC3ZA-KAZ33D3	6044981
	Spring terminals	MOC3ZA-KAZ34D3	6047866
230 V AC	Screw terminals	MOC3ZA-KAZ33A3	6044982
	Spring terminals	MOC3ZA-KAZ34A3	6047865
400 V AC	Screw terminals	MOC3ZA-KAZ33A6	6044983
	Spring terminals	MOC3ZA-KAZ34A6	6047864

EXAMPLE APPLICATION

Safe monitoring of automated guided system

Encoders are centrally connected to the Drive Monitor FX3-MOC, and thus enable speed and brake ramp monitoring. This monitoring optimizes the safety laser scanner's protective fields, which creates more effective use of the available space.



Complete solution on a servo press

There is a clear trend towards the use of electric drives in machine tool. Processes can be controlled more accurately, allowing product quality to be increased. Energy is supplied to the process in a more targeted manner, saving costs. Productivity is increased thanks to the faster traversing movements of the axes. With the Drive Monitor, Flexi Soft also offers the option of underpinning these benefits in terms of safety.

Safe drive monitoring with Safe Motion Control

On mechanically and hydraulically operated machines, the entire drive control system is "safely" disconnected from the energy supply when the safety light curtain is interrupted or the service doors are opened.

In an electrically driven axis, however, the safe Drive Monitor FX3-MOC uses the signal of a HIPERFACE® drive to achieve the desired shutdown functions and the required performance level (PL). If necessary, a second independent signal/encoder is also needed.



Safe and simple fulfillment of the required performance level (PL)!

For each Drive Monitor module, two encoders can be used and the following PLs can be achieved:

- For one axis with non-safe motor feedback (MFB) and an additional external encoder, up to PL e can be achieved
- For two axes, up to PL d can be achieved without an additional external encoder depending on the motor feedback (safe or non-safe MFB) being used
- A combination with a safe encoder is possible

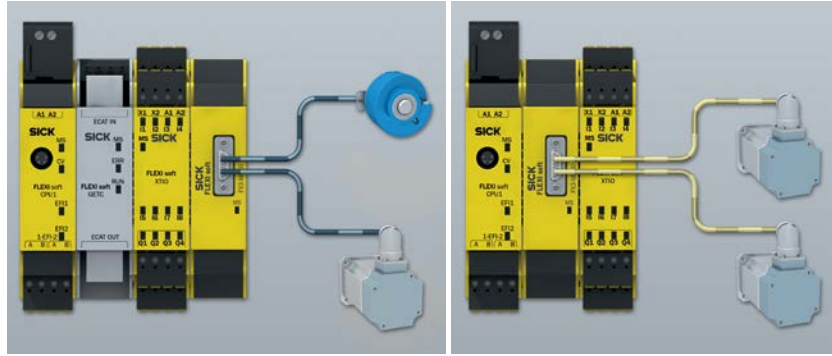

Functions used and benefits when implemented in a servo press

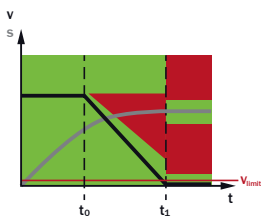

Safe stop 2 (SS2)

The SS2 function is activated by a safe signal when the safety light curtain is interrupted. The process of braking the press movement to a safe stop is initiated and monitored by the Drive Monitor.

The benefit: There is no need to activate the mechanical brake and the drive therefore does not have to be disconnected from the energy supply. Re-referencing is also not required; so downtimes are minimized.

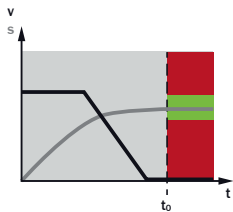

Safe operating stop (SOS)

The position of the press in the top dead center must be reliably monitored in the press cycle. This means that the drive's energy supply is maintained by the SOS safe drive function and the drive works against external forces and torques in order to hold its position. The operator can replace a workpiece safely.

The benefit: Fewer brake tests need to be carried out by the safe controller. Production is increased.

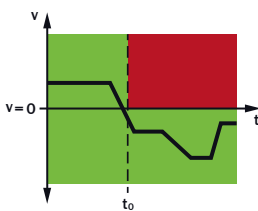

Safe direction (SDI)

The SDI safe drive function monitors whether the drive is only able to move in a defined direction. The application makes sure that the press movement is in the upstroke phase (upstroke muting).

The benefit: The operator can start to replace the workpiece in perfect safety. This saves time and increases productivity.

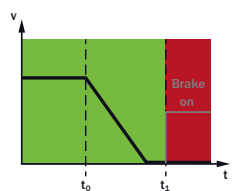

Safe brake control (SBC)

If implemented safety functions do not take effect – due, for example, to defective equipment – the additional SBC safe drive function ensures that a safety signal that controls suitable safe mechanical safety brakes is generated and monitored.

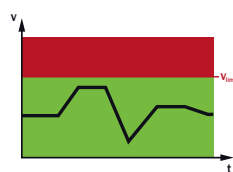

Safely limited speed (SLS)

SLS reliably monitors the speed of the drive when the press is set up. If a preconfigured speed limit is exceeded, the drive is switched off by the Drive Monitor, e.g., via SS2.

The benefit: Optimization of setup times

REGISTER NOW AT WWW.SICK.COM AND ENJOY ALL THE BENEFITS





- Select products, accessories, documentation and software simply and quickly.
- Create, save and share personalized wish lists.
- See the net price and delivery date for each product.
- Simple quote request, ordering and delivery tracking.
- Overview of all quotes and orders.
- Direct ordering: place even large orders quickly.
- View quote and order status at any time. Notification by e-mail in the event of status changes.
- Easy re-use of earlier orders.
- Convenient export of quotes and orders appropriate for your system.



SERVICES FOR MACHINES AND SYSTEMS: SICK LifeTime Services

The sophisticated and versatile LifeTime Services perfectly complement SICK's comprehensive product range. Services range from product-independent consulting to traditional product services.



-  **Consulting and design**
Safe and professional
-  **Product and system support**
Reliable, fast and on-site
-  **Verification and optimization**
Safe and regularly inspected
-  **Upgrades and retrofits**
Simple, safe and economical
-  **Training and education**
Practical, focused and professional

SICK AT A GLANCE

SICK is a leading manufacturer of intelligent sensors and sensor solutions for industrial applications. With more than 6.500 employees and over 50 subsidiaries and equity investments as well as numerous representative offices worldwide, we are always close to our customers. A unique range of products and services creates the perfect basis for controlling processes securely and efficiently, protecting individuals from accidents and preventing damage to the environment.

We have extensive experience in various industries and understand their processes and requirements. With intelligent sensors, we can deliver exactly what our customers need. In application centers in Europe, Asia and North America, system solutions are tested and optimized in accordance with customer specifications. All this makes us a reliable supplier and development partner.

Comprehensive services round out our offering: SICK LifeTime Services provide support throughout the machine life cycle and ensure safety and productivity.

For us, that is “Sensor Intelligence.”

Worldwide presence:

Australia, Austria, Belgium/Luxembourg, Brazil, Czech Republic, Canada, China, Denmark, Finland, France, Germany, Great Britain, Hungary, India, Israel, Italy, Japan, Mexico, Netherlands, Norway, Poland, Romania, Russia, Singapore, Slovenia, South Africa, South Korea, Spain, Sweden, Switzerland, Taiwan, Turkey, United Arab Emirates, USA

Detailed addresses and additional representatives - www.sick.com