



JORDAN VALVE

3170 Wasson Road • Cincinnati, OH 45209 USA
 Phone 513-533-5600 • Fax 513-871-0105
 info@richardsind.com • www.jordanvalve.com

I & M Mark 87 Series

Installation & Maintenance Instructions for Mark 87 Temperature Regulators (1/2" – 6")

Warning: Jordan Valve temperature regulators must only be used, installed and repaired in accordance with these Installation & Maintenance Instructions. Observe all applicable public and company codes and regulations. In the event of leakage or other malfunction, call a qualified service person; continued operation may cause system failure or a general hazard. Before servicing any valve, disconnect, shut off, or bypass all pressurized fluid. Before disassembling a valve, be sure to release all spring tension.

Please read these instructions carefully!

Your Jordan Valve product will provide you with long, trouble-free service if it is correctly installed and maintained. Spending a few minutes now reading these instructions can save hours of trouble and downtime later. When making repairs, use only genuine Jordan Valve parts, available for immediate shipment from the factory.

Ideal Installation

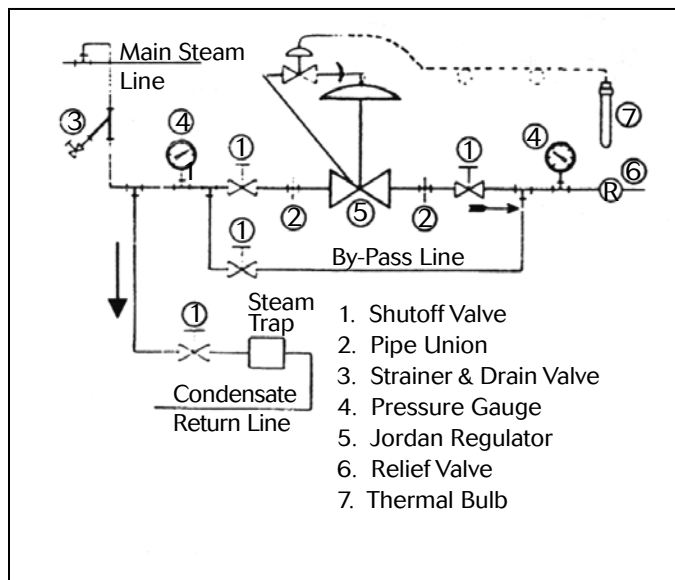

- To protect the regulator from grit, scale, thread chips, and other foreign matter, all pipe lines and piping components should be blown out and thoroughly cleaned before the valve is installed.
- Shutoff valves, pressure gauges, and bypass piping should be installed as indicated in the diagram to provide easier adjustment, operation, and testing.
- In preparing threaded pipe connections, care should be taken to prevent pipe sealing compound from getting into the pipe lines. Pipe sealing compound should be used sparingly, leaving the two lead threads clean. Jordan uses, and recommends, Seyco #2415 thread sealer Teflon ribbon.
- A line strainer should be installed on the inlet side of

the regulator to protect it from grit, scale and other foreign matter. A 0.033 perforated screen is usually suitable. Line strainers are available from Jordan Valve.

- Install the regulator in the highest horizontal line of piping to provide drainage for inlet and outlet piping, to prevent water hammer, and to obtain faster regulation.
- The flow arrow on the regulator body must be pointed in the direction of flow. The valve may be installed vertically or horizontally without affecting its operation.
- For best control, 3'0" straight sections of pipe should be installed on either side of the valve.
- To minimize condensation in hot vapor lines, upstream and downstream piping near the regulator should be insulated.
- For injection heating applications, the regulator should be installed above the maximum water level in the tank, or a check valve should be installed to prevent water from backing up into the regulator.
- For best regulation, the temperature regulator should be installed as closely as possible to the unit in which the temperature is being controlled.
- On steam control applications, install a steam trap of sufficient capacity to drain the coil or condenser. Be sure to have a good fall to the trap, and no back pressure. Best control is obtained when the coil or condenser is kept dry.
- Where surges are severe, a piping accumulator is recommended.

Operation

The direct acting pilot valve is normally open, allowing the upstream pressure to force the main diaphragm down to open the main valve seats. As the process temperature approaches the desired setting, the fluid in the bulb vaporizes, creating the necessary pressure on the pilot diaphragm to throttle the pilot valve toward the closed position. This starves the pressure supply to the main diaphragm and the lower spring beings to close the main valve. The reverse acting pilot is normally closed, and opens on an increase in temperature.

Start-Up Procedure

With the inlet, outlet and by-pass shut-off valves closed:

1. Fully open the outlet shut-off valve
2. Slowly open the inlet valve just enough to start flow through the regulator. Observe the downstream pressure gauge. Increase the downstream pressure slowly by gradually opening the inlet valve.
3. Do not fully open the inlet valve until you are sure that the regulator has control of the system. Usually, the handwheel on the inlet valve will turn freely when this point is reached.
4. To change the controlled temperature, rotate the adjusting wheel on the pilot valve upward to increase the temperature, and downward to decrease the temperature.

Troubleshooting

1. *Insufficient Heating (or Cooling)*

- A valve undersized for the application. Check capacity required and valve capacity.
- Line strainer or pilot strainer screen could be clogged. Blow down strainers or visually check that they are clear.
- Incorrect setting on range spring. Vary the setting and check response.
- Main valve diaphragm may be ruptured. See section on main valve maintenance.
- Malfunction of other piping components. Check for leaking traps and safety valves, inadvertently opened or closed valves.

2. *Overheating (or Cooling)*

- Incorrect setting on range spring. Vary the setting and check response.
- Pilot valve or main valve seats leaking. Close inlet shut-off valve, allow downstream pressure to bleed off, close outlet valve and remove loading pressure tubing. FOR HEATING APPLICATION: Heat the sensing bulb to approximately 20° - 30°F above the control point and/or reduce the compression of the adjusting spring to guarantee that the pilot valve is stroked closed. FOR COOLING APPLICATION: Cool the sensing bulb to approximately 20° - 30°F below the control point and /or increase the compression of the adjusting spring to guarantee that the pilot valve is stroked closed. Crack open inlet shut-off valve - if fluid issues from pilot valve point, the pilot seats are leaking. If the fluid issues from the main valve port, the main valve seats are leaking.
- By-pass shut-off valve leaking. During period of leakage, close outlet shut-off valve, observe thermometer.
- Bleed port in main valve clogged. Remove Upper Bonnet to gain access to bleed port and clean bleed

port. Follow instructions in section "To Remove Main Diaphragm".

- Thermal System Failure. See Series 80 I & M Sheet.

Controlled Temperature Fluctuates

- Valve oversized. Check capacity required and valve capacity.

Maintenance

WARNING: Be sure that there is no pressure in the valve before loosening any fittings or joints. The following steps are recommended.

1. Close inlet shut-off valve.
2. Allow pressure to bleed off through downstream piping. Do not cause a reverse flow through valve by bleeding pressure from upstream side of valve.
3. When downstream pressure gauge indicates no pressure in the line, close the outlet shut-off valve.
4. Close the control line shut-off valve.

Bulb Installation

The Thermal System is a hermetically sealed unit consisting of a sensing bulb, capillary tubing, protective armor, and actuator assembly. This unit contains the thermostatic charge that operates the temperature regulator. Please do not tamper with it. In case the charge is lost, the thermal system must be replaced as a complete unit. It is not repairable in the field and must be returned to the factory for repairs.

1. *Correct Installation* - For effective temperature control installation of the sensing bulb is essential. For best results, the bulb should be installed at a point of true representative temperature and where there is good circulation. A thermometer or other temperature sensing device (if used) should be placed as close as possible to the sensing bulb of the regulator.
2. Handle the capillary and armor carefully so they are not crushed, kinked or twisted. A bend of 4-1/2" radius or larger is recommended.
3. *Horizontal Mounting* - When the bulb is to be mounted horizontally, it must be turned so that the word TOP and center punch mark (stamped on the adapter) faces upward.
4. *Vertical Mounting* - No special precaution is required when the bulb is mounted vertically pointing down.
5. *Inverted Mounting* - A special capillary is required if the tip of the bulb will be higher than the capillary end. The temperature regulator equipped with

a standard capillary will not function properly in an inverted position.

6. *Insertion* - For accurate control, the entire length of the bulb should be inserted. Avoid locating a bulb in the direct path of steam or water. Never lay the bulb on the bottom of a tank. Approximately 8" is sufficient distance from the source of heat or coolant to the sensing bulb.
7. *Pipeline Mounting* - When installing the sensing bulb in piping, be sure that the pipeline is at least twice the diameter of the sensing bulb so that free flow is obtained around the bulb.
8. *Finned Bulbs* - Finned bulbs should be installed at right angles to the air movement. Good circulation is required to sense the average temperature.
9. When the bulb is installed at a point higher than the regulator itself, the range will probably be somewhat lowered. Conversely, the range will be raised if the bulb is installed between the regulator.

Pilot Valve

The pilot valve is a Jordan Mark 80 T.C.V. For servicing, refer to the Mark 80 Installation and Maintenance Sheet.

Main Valve

It is necessary to remove the main valve from the line only if the main valve seats must be replaced, inspected or adjusted. All other operations can be performed with the valve in the line and without disturbing the stroke adjustment.

To Remove Main Valve Seats

The seats of Jordan regulators are lapped to a light bank flatness. Maintaining such tolerances is of paramount importance for your assurance of excellent control and tight shut-off. Do not use metallic objects in removing the seats, and care in handling is imperative.

1. Remove the pilot tubing and the pilot valve with the mounting nipple.
2. With the main valve out of the line, remove the bolts securing the main valve cap to the main valve body and lift the cap straight up.
3. Lift the disc from the plate and place on a clean surface with the seating side up.
4. Place the valve body on a side. Hold one hand over plate to receive it and tap lightly on the back of the plate with a soft, blunt object; push the plate out evenly. Place the plate on a clean surface seating side up.

To Remove Main Valve Diaphragm and Disc Pin

1. Remove the spring cap. The spring and spring guide will come out with it.
2. Disconnect the loading pressure tubing from the upper bonnet, remove the bonnet bolts and upper bonnet.
3. Lift out the diaphragm assembly consisting of the diaphragm retainer, stroke stop shim (2-1/2" or 3" valve size only), diaphragms and diaphragm plate.
4. Fasten hub of diaphragm plate in a vise and unscrew diaphragm retainer. Remove stroke stop shim and diaphragms.
5. To remove stem and disc pin, hold the disc pin with a wrench and loosen the locknut, unscrew the stem.
6. Assemble valve in the reverse order of above, following the procedures for stroke adjustment outlined below.

Main Valve Stroke Adjustment

1. Do not tighten locknut on the stem; run it to the upper end of the thread with the disc pin located at above the center of the threaded section.
2. Place the plate and disc in the valve body so that the disc pin protrudes through the center slot in the plate and engages the disc. Use the following as a guide to properly install the plate and disc.
 - **1/2" – 1-1/4" Valve Sizes** - the scribed line on the side of the valve body locates the position of the index pin hole in the face of the plate. The arrow which is stamped on the disc should point to the index pin hole. (Since the disc can be rotated 180° in some sizes without affecting the stroke adjustment, there may be no arrow on the disc). The vertical milled portion of the valve cap serves as a guide for the disc. A 0.005" feeler gauge should be used to check the clearance between the valve disc and disc guides. The pressure ring has one lapped surface. This should face the plate.
 - **1-1/2" and 2" Valve Sizes** - Place the disc on the plate and install the disc guide screws. Tighten the screws but make sure that they do not bind the disc against the plate. Place the assembly in the valve body so that the orifices will be open when the disc is stroked down. (With working "TOP REVERSE" on plate at the top nearest diaphragm). Engage the disc with the disc pin and check to be sure that the plate seats solidly against the shoulder in the valve body. Rotate the assembly slightly to align the disc screws with the vertical centerline of the valve. The arrow on the disc should be pointing up to the wording "TOP REVERSE" on the plate.
 - **2-1/2" – 6" Valve Sizes** - the plates are stamped on the backside with the wording, "TOP DIRECT" and "TOP REVERSE" to indicate their proper position in the valve body. The wording "TOP REVERSE" is at

the top, nearest the diaphragm and the engraved arrow on the disc always points to the wording "TOP REVERSE" on the plate. Check that the index pins in the valve body engage the plate to align the plate in the body.

3. Place the diaphragm assembly on the stem with the diaphragm in its recess in the lower bonnet. Hold the diaphragm assembly firmly against the stop in the lower bonnet and push on the bottom of the stem so that it fully enters the socket in the diaphragm retainer. In this position, the disc should be in its lowermost position with the orifices of the disc and plate fully aligned. If the orifices are not fully aligned, rotate the stem clockwise to move the disc up, or counterclockwise to move the disc down.
4. When the orifices are aligned, remove the disc and plate and lock the locknut on the stem against the disc pin. Replace the disc and plate and recheck the orifice alignment.

The pilot valve, not shown here, is a Jordan Mark 80 TCV.

Torque Procedure For Cap & Spring Housing Bolts

1. Install all bolts hand-tight.
2. Torque the bolts in order of the bolt pattern to a value equal to 1/4 of the recommended torque value.
3. Re-torque each bolt to the recommended value using the same bolt pattern as shown.

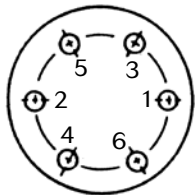

6 bolts
(or multiples)

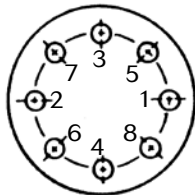

8 bolts
(or multiples)

1/2" – 2" Body/Cap: 200 in-lbs
 Upper Bonnet: 240 in-lbs
 Pilot Dome: 350 in-lbs

2-1/2" – 6" Body/Cap: 1080 in-lbs (90 ft-lbs)
 Upper Bonnet: 240 in-lbs
 Pilot Dome: 350 in-lbs

Illustration and Parts List (1/2" - 2")

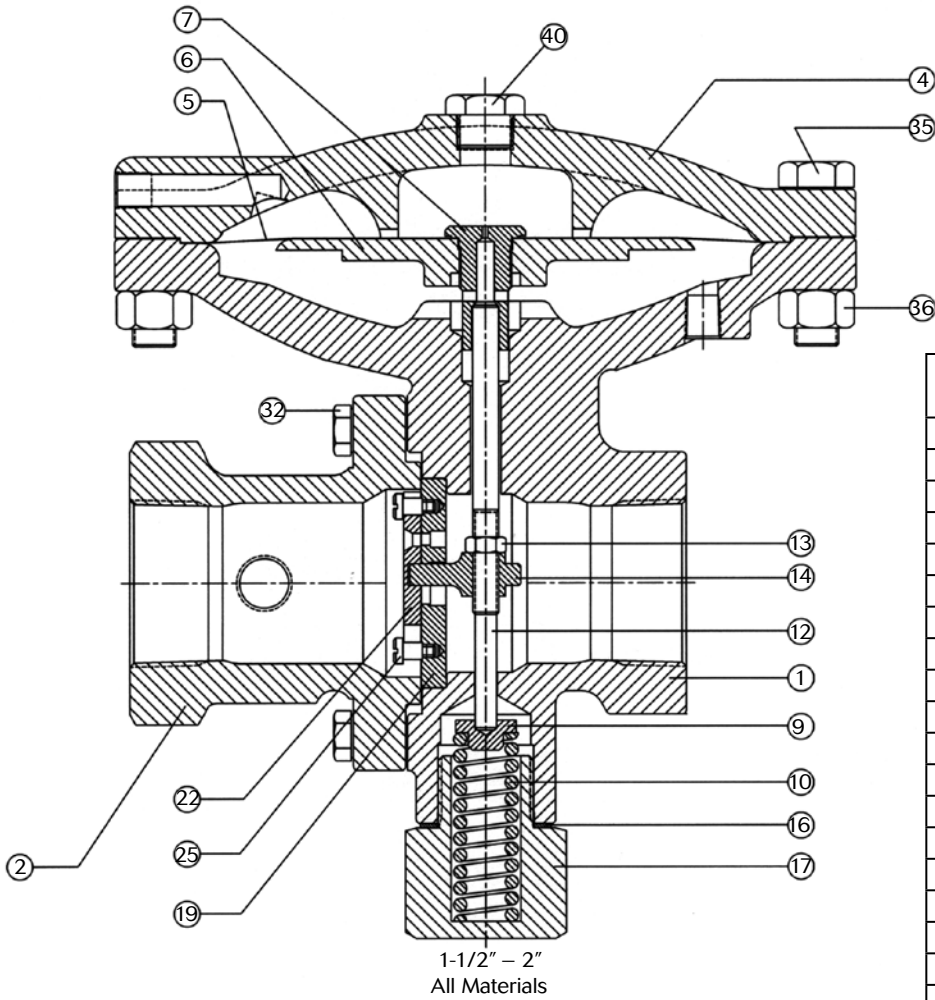

Item No.	Description
1	Body
2	Cap
4	Upper Case
5	Diaphragm
6	Diaphragm Plate
7	Diaphragm Retainer
9	Spring Seat
10	Return Spring
12	Stem
13	Locknut (Stem)
14	Disc Pin
16	Gasket (Bottom Cap)
17	Bottom Cap
19	Plate
22	Disc
24	Disc Guide (1/2" - 1-1/4" only)
25	Disc Guide (1-1/2" - 2" only)
32	Cap Screw (Cap/Body)
35	Bolt (Upper Bonnet/Body)
36	Nut (Upper Bonnet/Body)
38	MK 80 Pilot Valve
40	Pipe Plug

Seat Arrangement

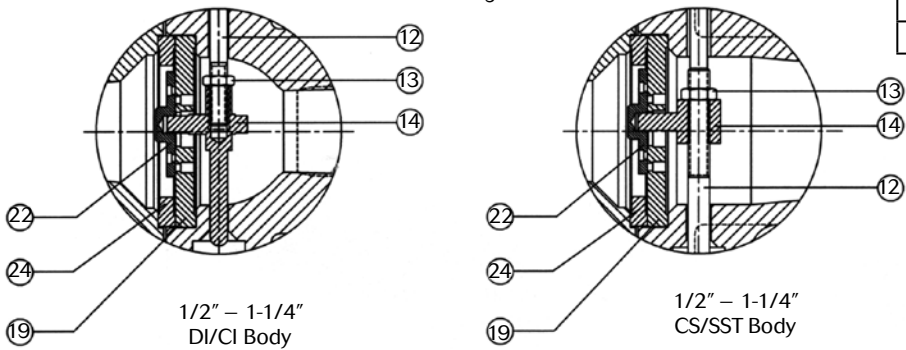
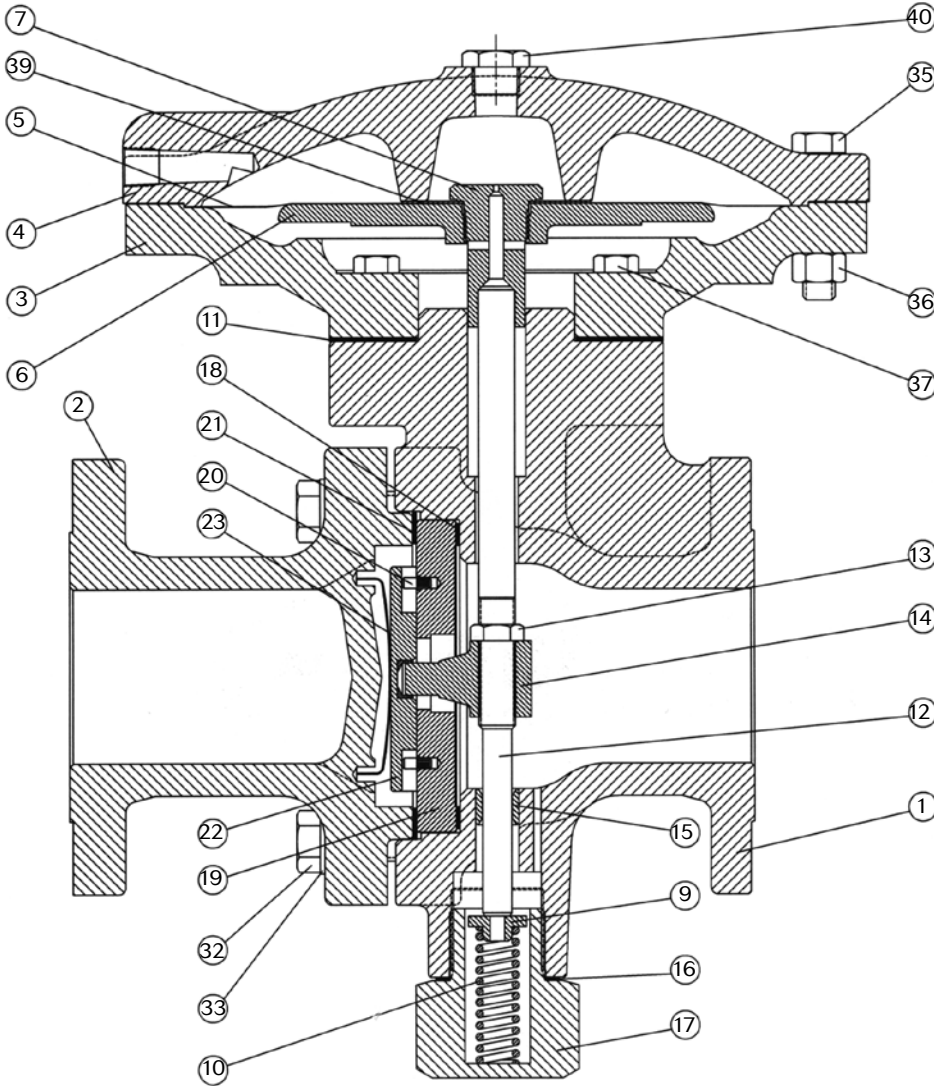

Illustration and Parts List (2-1/2" - 6")



Item No.	Description
1	Body
2	Cap
3	Lower Case
4	Upper Case
5	Diaphragm
6	Diaphragm Plate
7	Diaphragm Retainer
9	Spring Seat
10	Return Spring
11	Gasket (Upper Bonnet)
12	Stem
13	Locknut (Stem)
14	Disc Pin
15	Stem Bushing
16	Gasket (Bottom Cap)
17	Bottom Cap
18	Gasket (Body)
19	Plate
20	Guide Pin
21	Gasket (Cap)
22	Disc
23	Disc Spring
32	Cap Screw (Cap Body)
33	Lockwasher
35	Bolt (Upper Bonnet)
36	Nut (Upper Bonnet)
37	Cap Screw (Lower Bonnet)
38	MK 80 Pilot Valve
39	Stroke Stop Shim (2-1/2" - 3")
40	Pipe Plug

