

ADDENDUM TO OPERATING INSTRUCTIONS

FLAWSIC100 Flare

FLARE METER RETROFIT SOLUTION:
90° UPGRADE KIT

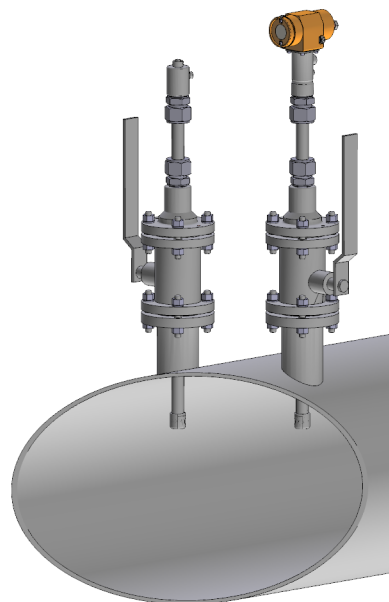

Document Information

Product

Product name: FLOWSIC100 Flare

Document ID

Title: Addendum to Operating Instructions
FLOWSIC100 Flare

Part No.: 8020368/183X

Version: 1-3

Release: 2020-06

Manufacturer

SICK Engineering GmbH
Bergener Ring 27 · D-01458 Ottendorf-Okrilla · Germany
Phone: +49 35205 52410
Fax: +49 35205 52450
E-mail: info.pa@sick.de

Trademarks

Windows is a Microsoft Corporation trademark.

Other product names used in this document may also be trademarks and are only used for identification purposes.

Original documents

The English version 8020368/183X of this document is an original document from the manufacturer.

SICK Engineering GmbH assumes no liability for the correctness of an unauthorized translation.

Please contact the publisher in case of doubt.

Legal information

Subject to change without notice.

© SICK Engineering GmbH. All rights reserved.

Warning Symbols



Warning

Warning levels / Signal words

HAZARD

Risk or hazardous situation which *will* result in severe personal injury or death.

WARNING

Risk or hazardous situation which *could* result in severe personal injury or death.

CAUTION

Hazard or unsafe practice which *could* result in personal injury or property damage.

NOTICE

Hazard which *could* result in property damage.

Information Symbols



Important technical information for this product



Important information on electric or electronic functions



Supplementary information

1	Important Information	5
1.1	General information	6
1.2	For your safety	6
1.3	Transport protection	6
2	Product Description	7
2.1	System overview	8
2.2	FLSE100 sender/receiver units	9
2.3	Mounting accessories	10
3	Mounting and Installation	11
3.1	Overview	12
3.2	Determining the measuring and installation location	12
3.3	Preparation of measurement point for retrofit	13
3.3.1	Components that can remain	13
3.3.2	Components that have to be replaced	14
3.4	Determining the geometrical installation parameters	15
3.5	Assembly	19
3.5.1	Prerequisites for assembly	19
3.5.2	Tools required	19
3.5.3	Fitting the sender/receiver units	20
3.5.4	Mounting the MCUP Control Unit	26
3.5.5	Mounting the adapter plate	26
3.5.6	Mounting MCUP on the adapter plate	28
4	Start-up and Parameter Settings	29
4.1	Sequence of start-up	30
4.2	Entering the linearization parameters for the FLSE100-EXS 90°	31
4.3	Retrofit of existing installations with 3.2 in Bias (6.4 in Spacing)	32
5	Maintenance	33
5.1	Removing the sender/receiver units	34
6	Specifications	37
6.1	Technical data	38
6.2	Dimensional drawings	39

FLWSIC100 Flare

1 Important Information

General information
For your safety
Transport protection

1.1 General information

This document supplements and is to be used only in combination with the currently valid Operating Instructions FLOWSIC100 Flare (Part No. 8013344). Special instructions for the FLOWSIC100 Flare 90° Upgrade Kit in this document overwrite related general information in the Operating Instructions FLOWSIC100 Flare.

1.2 For your safety



NOTICE:

- ▶ Read the Operating Instructions carefully before using the FLOWSIC100 Flare.
- ▶ Special attention must be paid to all safety instructions and warnings for assembly, installation and operation of the device!

1.3 Transport protection



NOTICE:

This section replaces § 1.5 "Transport safety device for retractable sender/receiver units" of the Operating Instructions FLOWSIC100 Flare.

To prevent transport damage, the sender/receiver units must be secured before each transport according to → Fig. 1.

- ▶ The transducers must be fully retracted and secured in place with the safety clamp.

Fig. 1

Safety clamp

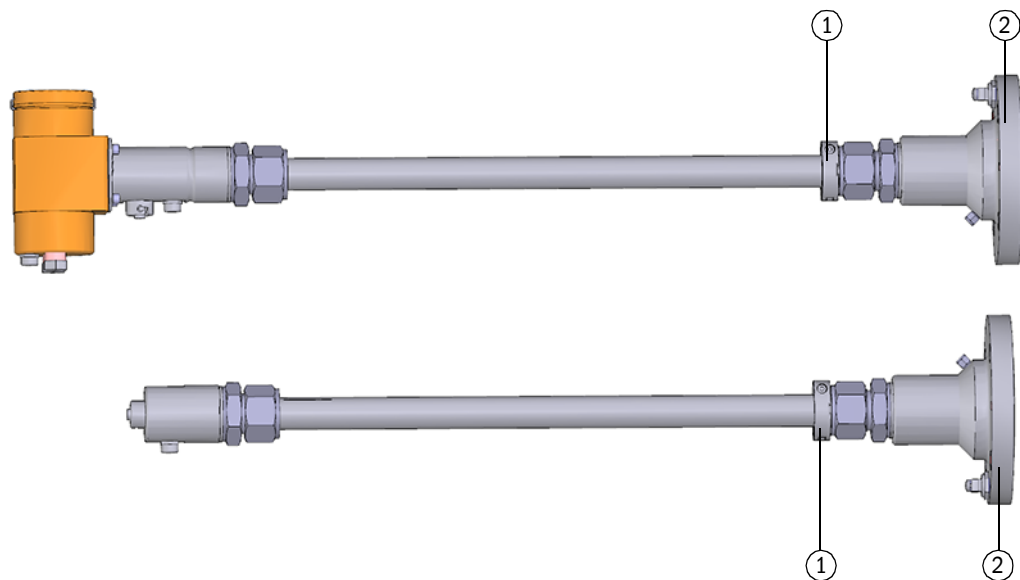

- 1 Safety clamp
- 2 Retraction flange

FLWSIC100 Flare

2 Product Description

System overview
FLSE100 sender/receiver units
Mounting accessories

2.1

System overview

The 90° Upgrade Kit consists of the following components (for a detailed description see → p. 13, § 3.3):

- FLSE100-EXS 90° sender/receiver units
For sending and receiving ultrasonic pulses, for signal processing and control of system functions (→ p. 9, § 2.2); the sender/receiver units are derived from the FLSE100-EXS and use special transducer design.
- MCUP control unit (see Operating Instructions FLOWSIC100 Flare § 2.2.4 “MCUP control unit”)
For control, evaluation and output of the sensor data connected via the RS485 interface
- Connection cable between the sender/receiver units
- Connection cable between sender/receiver units and MCUP
- Alignment tool for correct alignment of the sender/receiver units

Fig. 2

System overview 90° Upgrade Kit

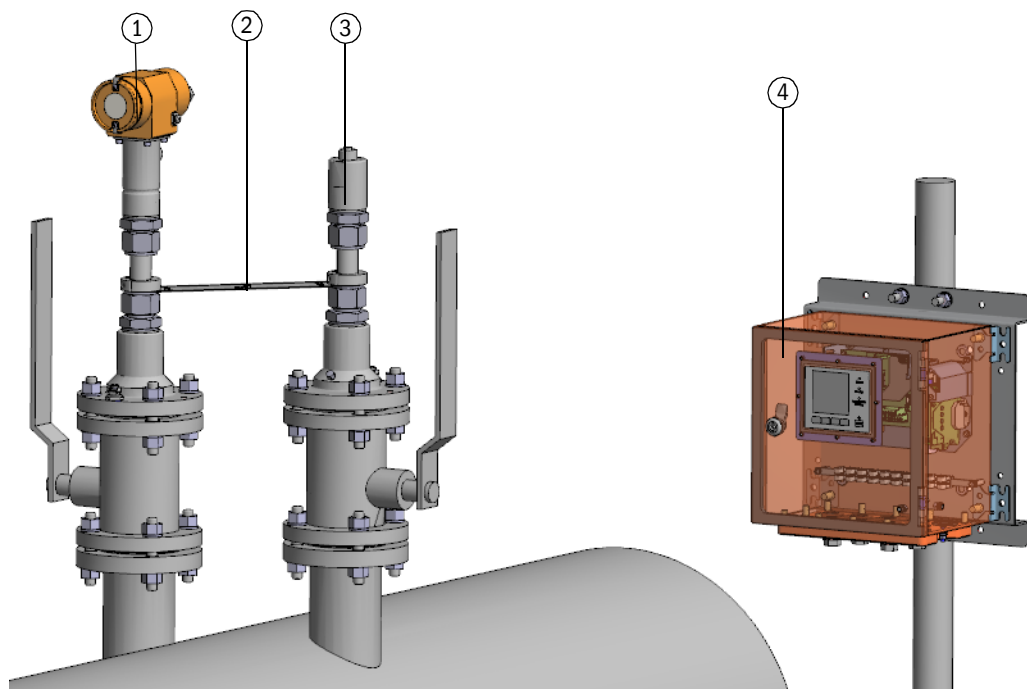

- | | |
|---------------------------------------|--------------------------------------|
| 1 Sender/receiver unit (master probe) | 3 Sender/receiver unit (slave probe) |
| 2 Alignment tool | 4 MCUP control unit |

2.2 FLSE100 sender/receiver units

Fig. 3 Schematic overview sender/receiver unit FLOWSIC100 Flare 90° Upgrade Kit

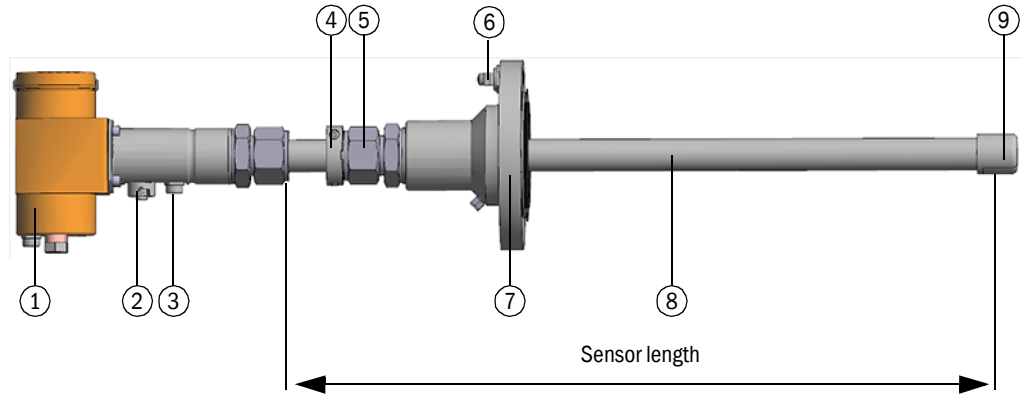

- | | |
|----------------------------|---------------------|
| 1 Electronics unit | 6 Ground terminal |
| 2 Connection | 7 Retraction flange |
| 3 Pressure balance element | 8 Duct probe |
| 4 Safety clamp | 9 Transducer |
| 5 Compression ring | |

Material for gas-affected parts (standard configuration)

Material	Component	Type FLSE100		
		EXS 90°	non-retract.	retract.
Stainless steel 1.4571	Connection for optional venting, retraction flange, sensor contour	x	N/A	x
Titanium	Duct probe, transducer	x	N/A	x
PTFE	Sealing duct probe in retraction flange at operating conditions	x	N/A	x
PTFE, with graphite	Sealing duct probe in retraction flange at maintenance conditions	x	N/A	x

Type code**NOTICE:**

This section supplements § 2.2.1.1 "Type code for sender/receiver units ATEX Zone 1, IECEx and Zone 2" of the Operating Instructions FLOWSIC100 Flare.
The type code has been extended for the FLOWSIC100 Flare 90° Upgrade Kit.

Parameter	Code	Design/Description	Type of sender/receiver unit
NL	924	For pipelines up to 24"	FLSE100-EXS 90°, retractable ³⁾
	948	For pipelines up to 48"	FLSE100-EXS 90°, retractable ³⁾
	972	For pipelines up to 72"	FLSE100-EXS 90°, retractable ³⁾
Sealing material in retraction mechanism	M	Metal	

³⁾ Flange connection prepared for mounting on counter flange 3" CL150 RF acc. to ASME B16.5

Application area, configurations

Type of sender/receiver unit	Gas temperature [°C]		Pressure [barg]	Active measuring path [mm]	Pipe diameter [mm]	NL [mm]
	standard range	high temperature range				
FLSE100-EXS 90°	-70 ... +180	-70 ... +280°C	19 full ANSI	150...374	300 ... 1800 (12" ... 72")	N/A Sensor length see → p. 9, § 2.2

Versions for low-temperature range -196 ... +100 °C on request

2.3

Mounting accessories**NOTICE:**

This section replaces § 2.2.2 "Mounting Accessories" of the Operating Instructions FLOWSIC100 Flare.

All accessories necessary for installation of the FLOWSIC100 Flare 90° retrofit solution are included in the 90° Upgrade Kit and described in this document.

FLWSIC100 Flare

3 Mounting and Installation

Overview

Determining the measuring and installation location

Preparation of measurement point for retrofit

Determining the geometrical installation parameters

Assembly

3.1 **Overview**

To install the FLOWSIC100 Flare 90° Upgrade Kit, proceed as follows:

- ▶ Ensure suitable mounting conditions and sufficient clearance space for installation, → p. 12, § 3.2.
- ▶ Prepare the measurement point for retrofit, → p. 13, § 3.3.
- ▶ Determine the geometrical installation parameters, → p. 15, § 3.4.
- ▶ Install the sender/receiver units and the MCUP control unit, → p. 19, § 3.5.

3.2 **Determining the measuring and installation location**



NOTICE:

This section replaces § 3.1.1 “Determining the measuring and installation location” of the Operating Instructions FLOWSIC100 Flare.

The 90° Upgrade Kit serves to replace an existing installation; the installation location must fulfill the following requirements:

- Counter flange: CL150 RF acc. ASME B16.5, full bore
- Minimum inner diameter of existing nozzle and ball valve: 50 mm

Clearance for fitting/removing the sender/receiver units

Fig. 4

Clearance for fitting/removing the sender/receiver units

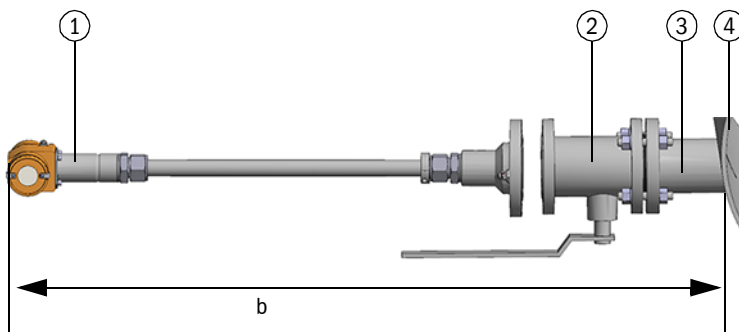

- 1 Sender/receiver unit
- 2 Ball valve
- 3 Nozzle
- 4 Pipeline

Sender/receiver units designed to fit counter flange CL150 RF acc. ASME B16.5

Type	NL (acc. type code)	Retractable	b
			mm (inch)
FLSE100-EXS 90°	924	x	1048 (41.3) + length of ball valve and nozzle
	948	x	1170 (46.1) + length of ball valve and nozzle
	972	x	1292 (50.9) + length of ball valve and nozzle

Subject to change without notice

3.3 Preparation of measurement point for retrofit

Prior to the installation of the FLOWSIC100 Flare retrofit solution, the measurement point has to be prepared. Some components of the existing installation have to be replaced while others can remain and be used again.

The following schematic drawing shows an application overview with the components that can remain (green colored).

Fig. 5 System overview showing already replaced SICK sensors [4] and SICK electronics unit [5]

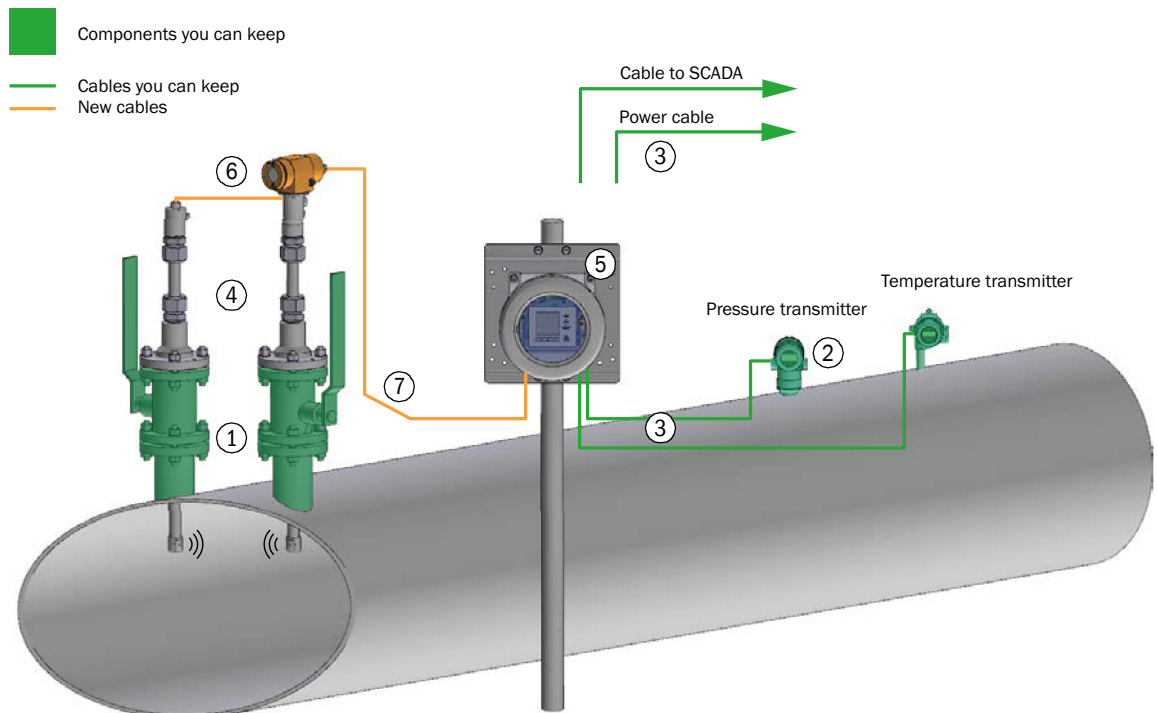

3.3.1 Components that can remain

Nozzles / Shut-off Valves [1]

Since existing nozzles and shut-off valves can be used, no hot-tapping or depressurization of the Flare gas line is needed.

- ▶ Check the correct function and leak tightness of the nozzles and shut-off valves. The sealing face of the shut-off valve shall not be damaged and has to be clean and free of corrosion in order to ensure the correct fit of the new gaskets.

p/T Transmitters [2]

The existing pressure and temperature transmitters can remain and be used again.

- ▶ Check the correct function of the transmitters.

Cables [3]

Most cables going to the electronics unit of the existing flare gas meter can be used again if the SICK electronics unit is mounted at the same location.

The following cables can remain:

- Connection cable p/T Transmitter to electronics unit
- Power supply cable
- Connection cable SCADA /DCS System to electronics unit

3.3.2

Components that have to be replaced**Ultrasonic Transducers [4]**

The ultrasonic transducers are the actual flow sensors and have to be replaced. The existing ultrasonic transducers have to be removed from the flare gas line.

- ▶ After retraction of the ultrasonic transducers make sure that the shut-off valve is closed tightly and covered with a blind flange to prevent soiling.

The installation of the SICK ultrasonic transducers is described in → p. 20, § 3.5.3.

Electronics Unit [5]

The electronics unit is the central component that powers the ultrasonic transducers, does calculations and transmits data to SCADA/DCS. The existing electronics unit has to be removed.

- ▶ Carefully unplug and disconnect all connected cables. Do not use a wire cutter if the cables shall be reused. Mark the cables that shall be reused according to their function and polarity [e.g. p/T, 24V,...]
- ▶ The FLOWSIC100 Flare retrofit scope contains an adapter plate to mount the SICK electronics unit (MCUP) at the original location.

The installation of the SICK electronics unit (MCUP) including the adapter plate is described in → p. 26, § 3.5.5.

Cables [6] + [7]

- The existing connection cable between the ultrasonic transducers [4] and the electronics unit [5] cannot be reused and has to be removed.

**NOTICE:**

If your cables are installed in conduits, consider the use of a taut wire when retracting the existing cables to reuse the conduits.

- The interconnection cable between the SICK ultrasonic transducers [6] is part of the FLOWSIC100 Flare retrofit scope and will be delivered as accessory.
- The connection cable [7] between the SICK ultrasonic transducer [4] and the SICK electronics unit (MCUP) [5] is not part of the FLOWSIC100 Flare retrofit scope of delivery and has to be installed by plant operator. SICK uses an industry standard twisted pair cable:
 - Li2YCYv(TP), 2x2x0.5 mm² twisted pair; with reinforced black outer sheath
 - Maximum length: 1000m (3300ft)

This cable must be sourced locally.

**NOTICE: Explosion hazard**

- ▶ Electrical installation shall be carried out acc. to IEC 60079-14.
- ▶ In addition national and/or local regulations have to be considered.
 - In the US install acc. to the NEC.
 - In Canada install acc. to CEC part 1.

3.4

Determining the geometrical installation parameters



NOTICE:

This chapter replaces § 3.3.1.4 “Determine path angle and path length“ of the Operating Instructions FLOWSIC100 Flare.

Exact values for geometrical installation parameters must be calculated to lower the uncertainty of measurement.

- The following parameters must be calculated:
- Path Angle between ultrasonic transducers [α]
- Path Length between ultrasonic transducers [L]
- Pipe Diameter [Di]
- Cross-sectional Area of the pipe [Area]

Furthermore the Setup Distance [A] will be calculated which is needed for the correct installation of the ultrasonic sender / receiver units (→ p. 20, § 3.5.3).



The Geometry Calculator software to perform these calculations can be found on the Product CD.

Calculation input values



NOTICE: Maximum tolerances

- Maximum tolerances of the input values dimensions.
- Maximum tolerance $\pm 1 \text{ mm} / \pm 1^\circ$



NOTICE: Unit input values

The units of the input values can be altered by clicking into the unit cell. A Drop-down menu will give you different metric and imperial possibilities.

Fig. 6

Geometry Calculation (example)

Geometry Calculation
FLOWSIC100 FLARE 90°UPGRADE KIT

Project: _____

TAG Number: _____

Customer: _____

Contact name: _____

Address: _____



Input values:

a	Nozzle distance	240,00 mm
β	Ray rescue angle	12,00 °
γ	Path angle nominal	45,00 °

Results:

L	Path length	0,202 m
α	Path angle	46,12 °

Subject to change without notice

- 1 Nozzle Distance [a]: Distance between the two mid-points of the existing weld-on nozzles. Measure this value as shown in → Fig. 7.

Fig. 7

Nozzle Distance [a]

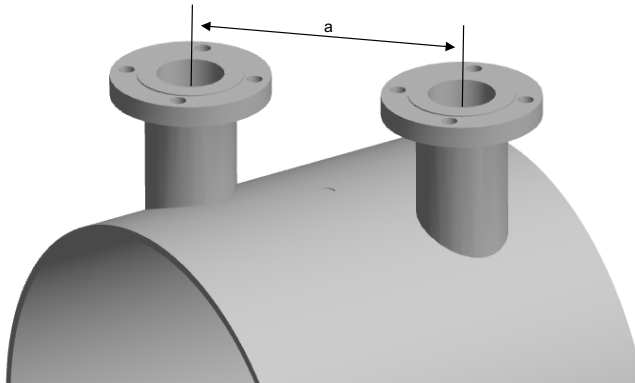

- 2 Ray Rescue Angle [β]
For an optimized adjusted measuring system for high velocities a turning of sensor B is recommended. A ray rescue angle of 12° should be realized. The delivered alignment tool can be used for easy adjustment during mechanical installation.
- 3 Nominal path angle [γ]
The nominal path angle is defined by the center point of the nozzle of sensor a referring to the axial pipe direction. This value will be used for calculation of path length and real path angle α .
- 4 Real path angle [α]
Real path angle is defined by the center points of the sensor membranes referring to the axial pipe direction. This value is different to the Nominal path angle because of the used ray rescue angle. It has to be entered in the SOPAS program for firmware configuration of the whole system.
- 5 Ultrasonic sensor type
The type of the installed ultrasonic sensors has to be set. You can find the type description on the type plate of the ultrasonic sensor.

Type plate	Nominal Pipe Size
FLSE100-EXS 924...	Up to 24"
FLSE100-EXS 948...	Up to 48"
FLSE100-EXS 972...	Up to 72"

- 6 Sensor length
SICK supports 3 different standard transducer lengths to achieve an optimized installation space referring to the pipe size. The sensor length is defined from the bottom of the metal screw till the center point of the membrane. The geometry calculator sets the correct sensor length automatically when choosing the installed ultrasonic sensor type.
- 7 Pipe Circumference [u]
Measure the outer circumference of the pipe with a measuring tape.
- 8 Wall thickness [s]
The wall thickness can be found in the commissioning documentation or in the program parameter sheet of the existing flare meter.

Calculation results

$$\text{Setup Distance [A]} = \text{Sensor length} - \text{Wall thickness} - 0.4 * \text{Radius (inside)}$$

Fig. 8

Ultrasonic transducer installation

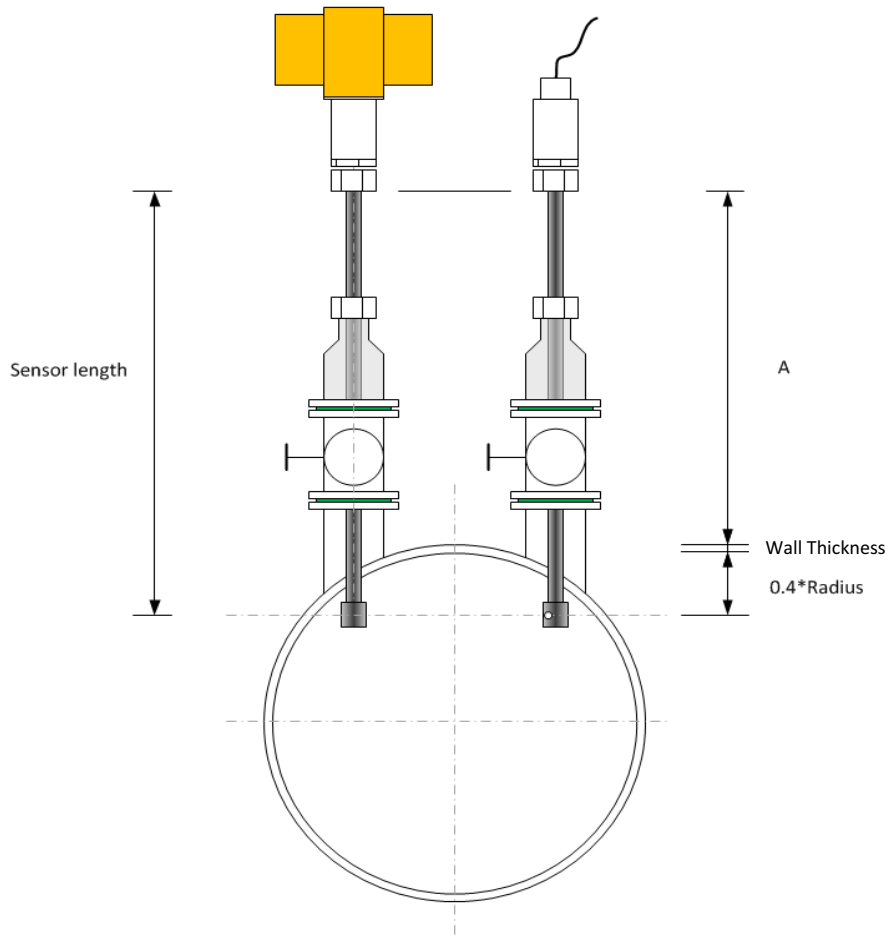
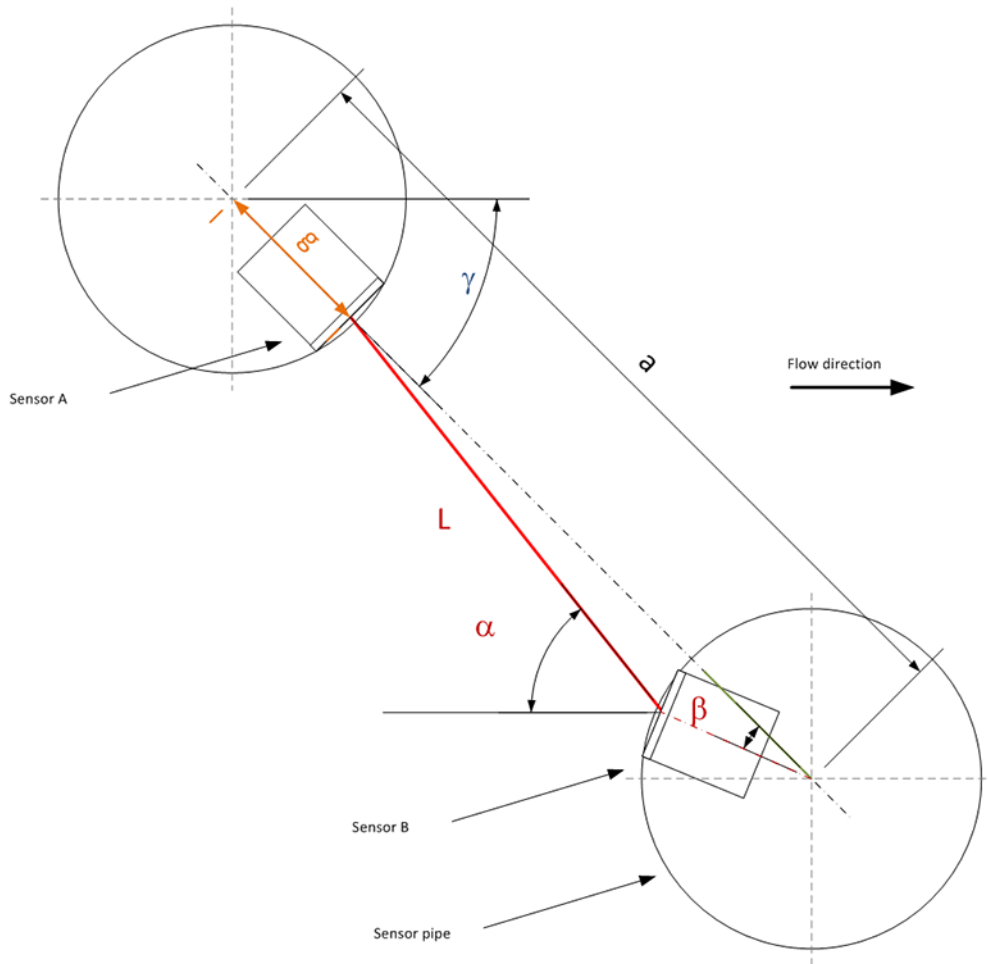

Fig. 9 Top to bottom view (schematic)



The results of the calculation are needed for the correct installation (→ p. 19, § 3.5) and commissioning (→ p. 30, § 4.1) of the FLOWSIC100 Flare 90° Upgrade Kit.

3.5 Assembly

3.5.1 Prerequisites for assembly

- ▶ The pressure in the pipe line does not exceed the maximum installation pressure of 0.5 bar (g).



WARNING: Maximum pressure for use of the retraction mechanism

- ▶ Maximum pressure for use of retraction mechanism: 0.5 bar (g)
- ▶ Installation/demounting is possible up to 5.5 bar (g) with an additional extraction tool (available on request).

- ▶ Preparation work has been completed, → p. 13, § 3.3.

Fig. 10

Measurement point prepared for retrofit



3.5.2

Tools required

- Jaw wrench size 24
- Jaw wrench size 50
- Allen key size 4
- Folding rule

3.5.3 Fitting the sender/receiver units



NOTICE:

- ▶ Observe the notes given for the installation of the sender/receiver units in § 3.6 “General notes for installation of sender/receiver units“ of the Operating Instructions FLOWSIC100 Flare.
- ▶ Observe the safety notes given in § 1 “Important Information“ of the Operating Instructions FLOWSIC100 Flare.

Fig. 11 Overview

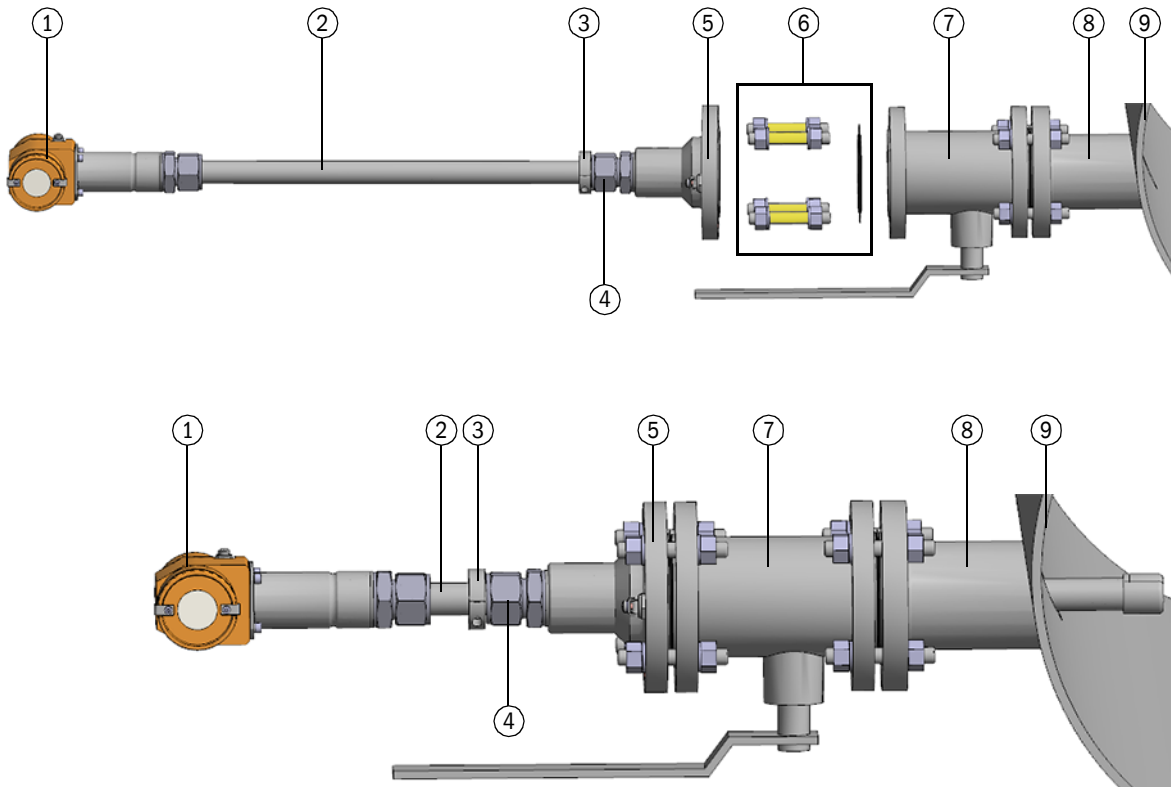

- | | |
|---|--|
| <ul style="list-style-type: none"> 1 Electronics unit 2 Duct probe 3 Safety clamp 4 Clamping ring screw connection 5 Retraction flange | <ul style="list-style-type: none"> 6 Mounting kit (including gasket, fastening screws, nuts, washers and alignment sleeves) 7 Ball valve 8 Nozzle 9 Pipeline |
|---|--|

Use of the alignment sleeves

The alignment sleeves are included in the mounting kit and serve to ensure the centering of the process flanges of the sender/receiver units.

Fig. 12

Alignment sleeves

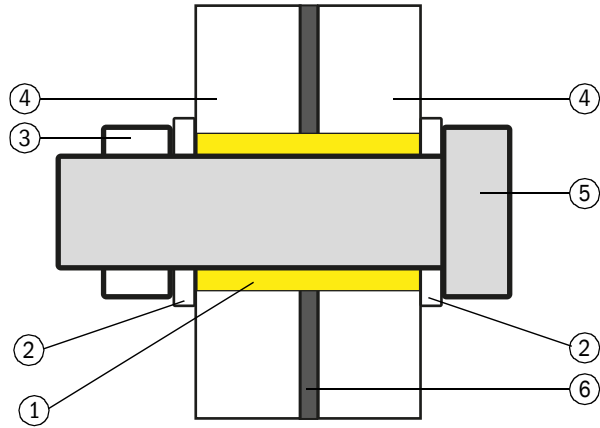

- 1 Alignment sleeve
- 2 Washer
- 3 Nut

- 4 Flange
- 5 Fastening screw
- 6 Gasket

Installing the sender/receiver units

- To install the sender/receiver units, proceed as follows:



NOTICE:

SICK recommends to install the sender/receiver units with two persons.

- 1 Make sure the ball valves are closed.
 - If applicable, close ball valves.
 - If applicable, remove blind flange.
- 2 Position the graphite seal.

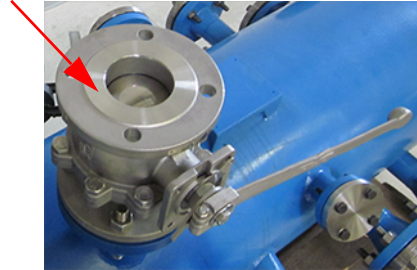

- 3 Install the passive sender/receiver unit (without electronics head) into the downstream ball valve:
 - Position the probe on the downstream nozzle.
 - Make sure the graphite seal does not move during positioning.
- 4 Insert the four bolts including the alignment sleeves (→ Fig. 12) and secure in place with jaw wrench size 24.
- 5 Open the ball valve.

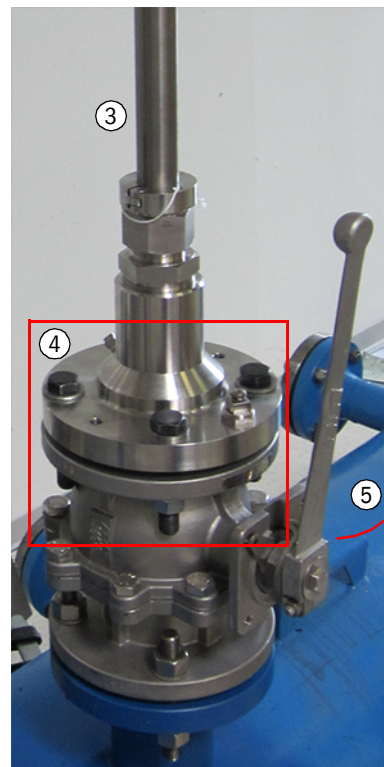

WARNING:

If gas escapes, do not continue, close the ball valve again and contact SICK Service.



NOTICE:

The clamping ring screw connection has not yet been tightened.

- Secure the probe with one hand while the safety clamp is released. The probe can be damaged when it slides in uncontrolled.

- 6 Loosen the safety clamp with an Allen key size 4.
- 7 Push the probe carefully into the pipe into the correct position.
For the correct distance, see → p. 15, § 3.4, Setup Distance [A].
Make sure, the probe does not slide in too far, otherwise the probe could be damaged.
- 8 Use the safety clamp to secure the probe in place.
- 9 Install the master probe (with electronics head) into the upstream ball valve as described before.

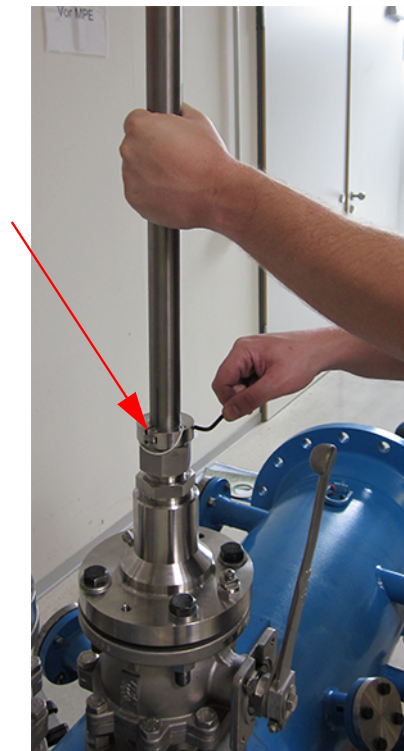

- 10 Select the alignment tool from the mounting kit.
There are 3 different alignment tools available. Select the fitting alignment tool for the nozzle distance of your installation.
- 11 Make sure both probes were inserted into the pipe by the same distance (→ p. 15, § 3.4, Setup Distance [A]) .

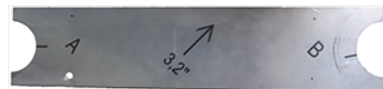

If you have to correct the distance, SICK recommends to secure the probes with the safety clamps and correct the distance of both probes alternating in small steps until the right distance has been ensured.

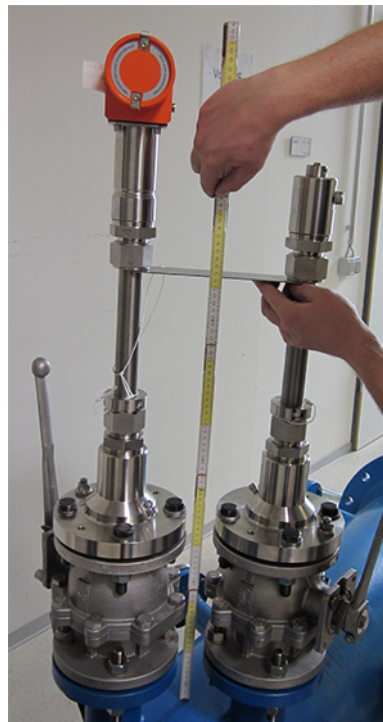

12 Secure the clamping ring in place:

- ▶ First tighten the clamping ring screw connection hand-tight.
- ▶ Turn with a size 50 jaw wrench a further half turn.
- ▶ Then release the clamping ring screw connection a half turn again.

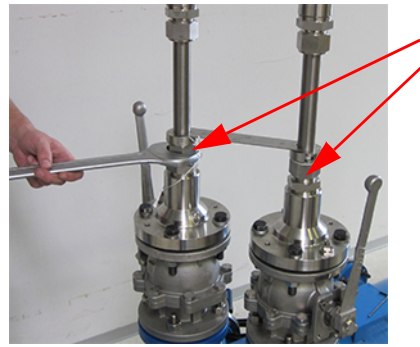

13 Repeat for second probe.

14 Position the alignment tool so that the arrow points in flow direction.

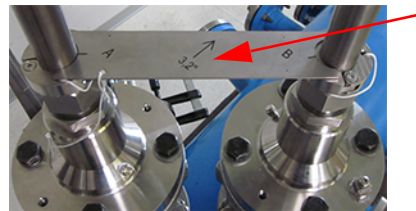

15 The markings must match on the probes and the alignment tool: If necessary, turn the probes to ensure correct alignment.

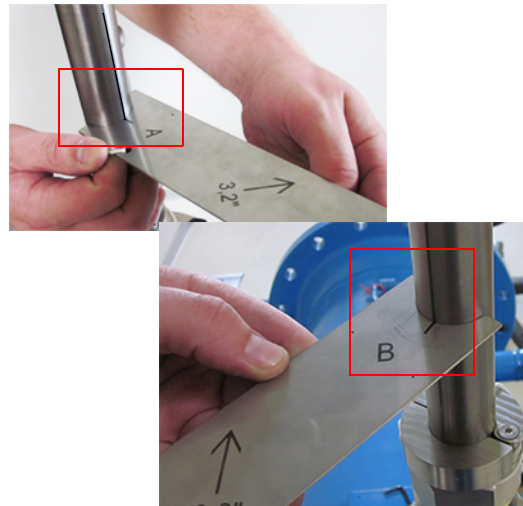

16 Tighten the clamping ring screw connection a half turn with a size 50 jaw wrench again.

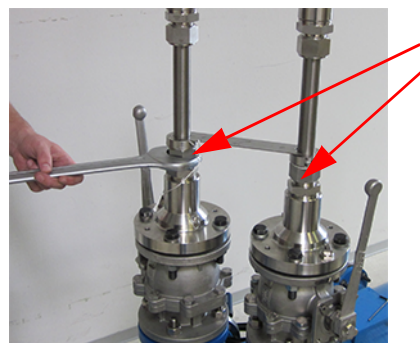

- 17** Fasten the alignment tool under the transport protection.
Make sure the loss protection of the alignment tool is not trapped.



- 18** After installation, perform a leak tightness check by appropriate means, e.g. leak detection spray.

- 19** Interconnect master and slave sender/receiver unit.

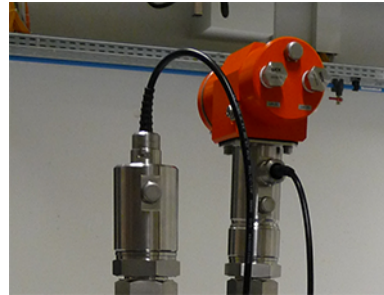

- 20** Mount the MCUP, → p. 26, § 3.5.4.

- 21** Proceed with the electrical installation as described in Operating Instructions FLOWSIC100 Flare, § 3.7 “Electrical Installation”.
Install acc. to figure “FLOWSIC100 EXS/EXPR cabling” in § 3.7.6 “Cabling” of the Operating Instructions FLOWSIC100 Flare.

3.5.4 Mounting the MCUP Control Unit

3.5.5 Mounting the adapter plate

**NOTICE:**

The adapter plate serves to mount the SICK electronics unit (MCUP) at the original location of the previously installed electronics unit.

- ▶ Before installation, make sure the previously installed electronics unit has been removed, → p. 14, § 3.3.2.

Dimensions

For the dimensions of the adapter plate see p. 40, Fig. 21

Mounting the adapter plate to the wall

- ▶ Use the holes marked in → Fig. 13 to mount the adapter plate to the wall.

Fig. 13

Mounting the adapter plate to the wall

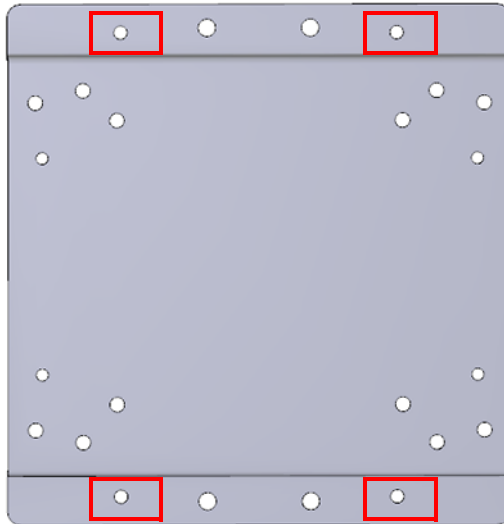

Mounting the adapter plate on a 2-inch post

- ▶ Use the mounting kit with round steel bows (Part no. 2061076) to fix the adapter plate on a 2-inch post.
- ▶ Use the holes marked in → Fig. 14.

Fig. 14

Mounting the adapter plate on a 2-inch post

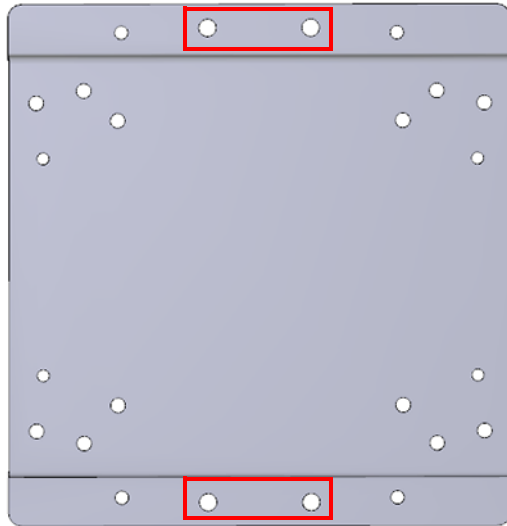

- ▶ Fix the round steel bows with the washers and screw nuts included in the mounting kit.

Fig. 15

Adapter plate mounted on a 2-inch post

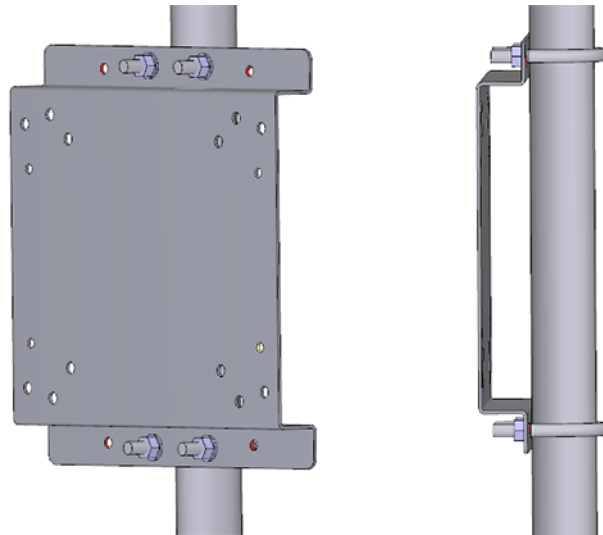

3.5.6 Mounting MCUP on the adapter plate

- ▶ After mounting the adapter plate to the wall or a 2-inch post, mount the MCUP on the adapter plate.
- ▶ Use the bolts, washers and screw nuts included in the mounting kit (Part no. 2061075) to fix the MCUP.

Fig. 16 Mounting MCUP on the adapter plate (example)

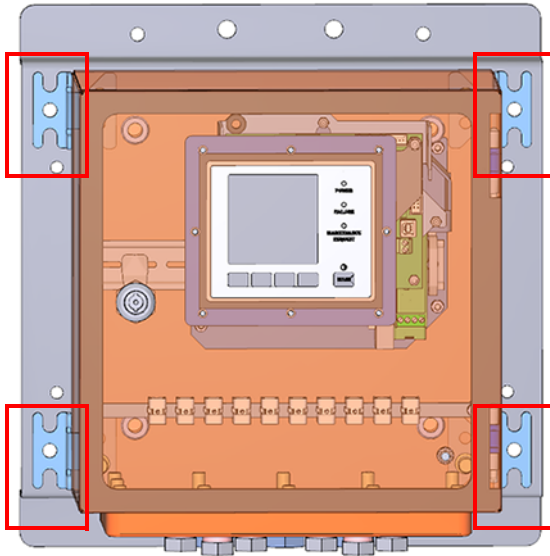

FLWSIC100 Flare

4 Start-up and Parameter Settings

Sequence of start-up

Entering the linearization parameters for the FLSE100-EXS 90°

Retrofit of existing installations with 3.2 in Bias (6.4 in Spacing)

4.1 Sequence of start-up

Follow the instructions in the Operating Instructions FLOWSIC100 Flare, § 4 "Start-up and Parameter Settings":

- 1 Install the operating and parameter program SOPAS ET, see Operating Instructions FLOWSIC100 Flare, § 4.1.2 "Installing the operating and parameter program SOPAS ET".
- 2 Connect to the device, see Operating Instructions FLOWSIC100 Flare, § 4.1.3 "Connecting to the device".
- 3 Enter application-specific parameters in the sender/receiver units:
Use the parameters determined in this document, → p. 15, § 3.4.
- 4 Enter the linearization parameters as described in this document, → p. 31, § 4.2.
- 5 For retrofit of existing installations with "6.4 in. Spacing", additionally adapt Cv_1, → p. 32, § 4.3.
- 6 Proceed as described in the Operating Instructions FLOWSIC100 Flare § 4.3.4 "Determining the check cycle" and following.

4.2 Entering the linearization parameters for the FLSE100-EXS 90°

Configure the linearization parameters during commissioning:

- ▶ Log in as “Service” (password “service”) and set the MCUP to “Maintenance” mode.



NOTICE:

No other parameters or settings may be changed while logged into access level 2 - “Service”, except for those described in this section. All other changes to settings may only be carried out using the access levels 0 - “Operator” or 1 - “Authorized client”. The manufacturer is not liable for any disruption caused by incorrect settings made by the user in SOPAS.

- ▶ Select the “Parameter / Measuring Point 1(2/3) / Measuring Point Parameters” directory.
- ▶ Select the correct “Nominal diameter (inch)”.
- ▶ Select the following correction method: “Polynomial correction (5th order)”.
- ▶ Enter the “Linearization parameters” listed in Table 1.

Fig. 17 Measuring Point Parameters

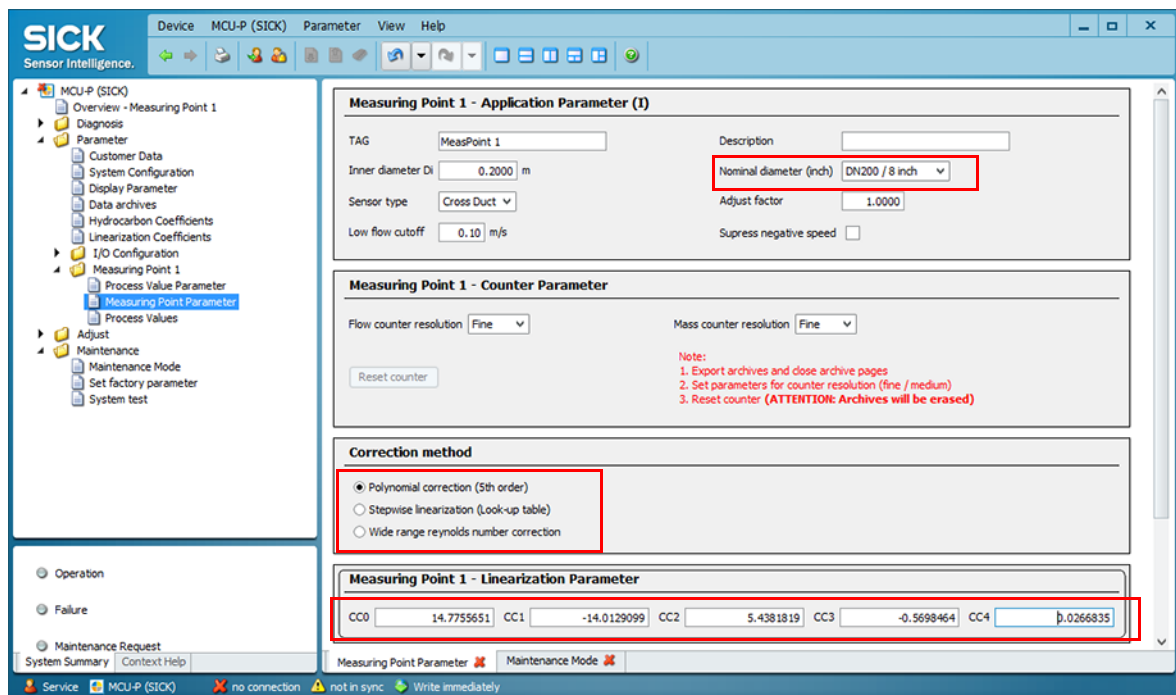

Table 1 Linearization Parameters

CC0	14.77556555
CC1	-14.01291034
CC2	5.438181823
CC3	-0.5698463867
CC4	0.02668352694

Subject to change without notice

4.3 Retrofit of existing installations with 3.2 in Bias (6.4 in Spacing)

Retrofit solutions are available for the following installation distances:

- 12.73": 4.5" Bias (9" Spacing)
- 14.14": 5" Bias (10" Spacing)
- 9,05": 3.2" Bias (6.4" Spacing)

Fig. 18

Installation distance

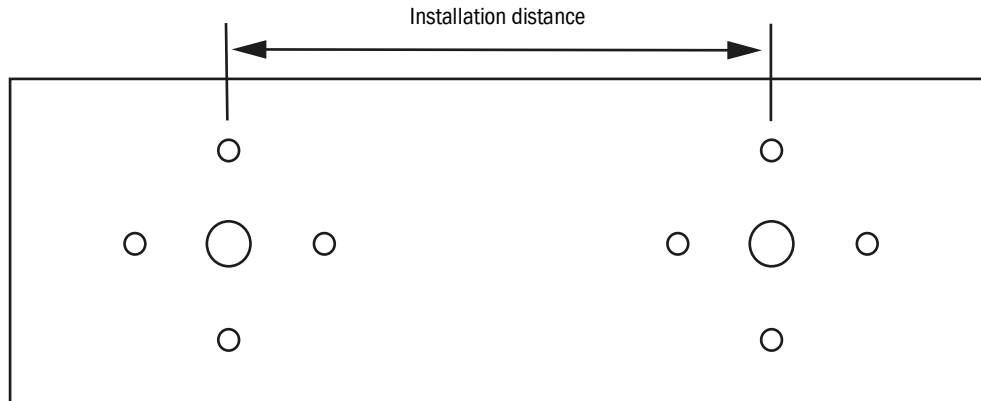

For installations with a 3.2" Bias (6.4" Spacing), the following adaptation is necessary in addition to the changes in → p. 31, § 4.2 of this document:

- ▶ In the device window of the sender/receiver units, open the "Configuration/Application Parameters" directory.
- ▶ In the "Calibration coefficients" section, set "Cv_1" to 1.05.

Fig. 19

"Configuration/Application Parameters"

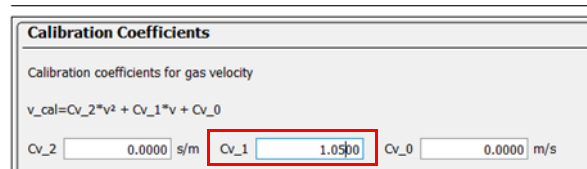

For the other spacing variants, the value Cv_1 remains at 1.

FLWSIC100 Flare

5 Maintenance

Removing the sender/receiver units

5.1

Removing the sender/receiver units

WARNING: Maximum pressure for use of the retraction mechanism

- ▶ Maximum pressure for use of retraction mechanism: 0.5 bar (g)
- ▶ Installation/demounting is possible up to 5.5 bar (g) with an additional extraction tool (available on request).

1 Remove all electrical connections.



NOTICE:

- ▶ Do not close the ball valves yet!
The sender receiver units have not been retracted yet and will be damaged when closing the ball valve.

2 Remove safety clamp and alignment tool.

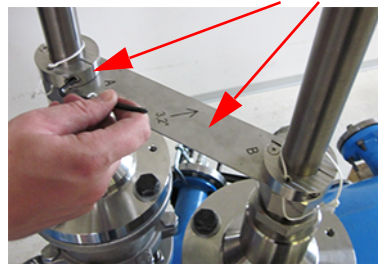

3 Fully unscrew the clamping ring screw connection.



4 Fully pull out the probe to the stop (audibly).
The probe has been fully retracted when the marking on the duct probe is visible.

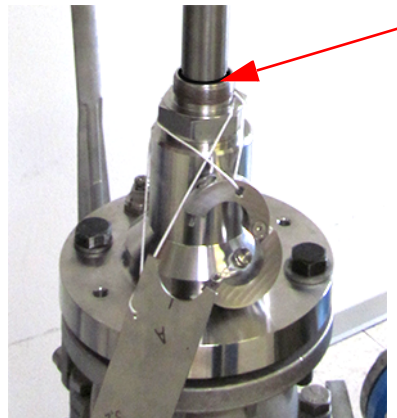

- 5 Secure the probe with the safety clamp in place.
Make sure that the probe does not slide back into the pipeline.
Perform for both probes.

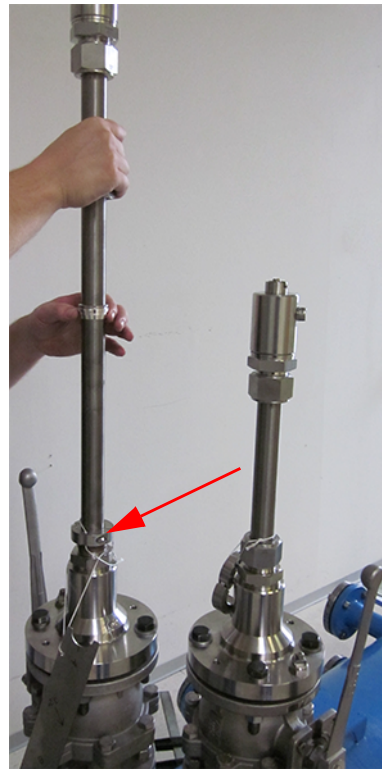

- 6 Close the ball valve.

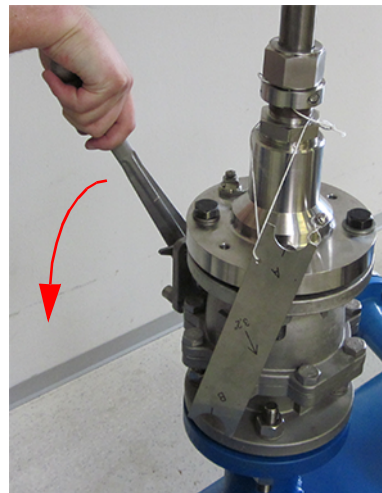

NOTICE:

It must be possible to close the ball valve without resistance.

If this is not possible:

- ▶ Make sure the probe has been pulled out fully.

- 7 Unscrew the flange bolts.
- 8 Remove the sender /receiver unit from the ball valve.

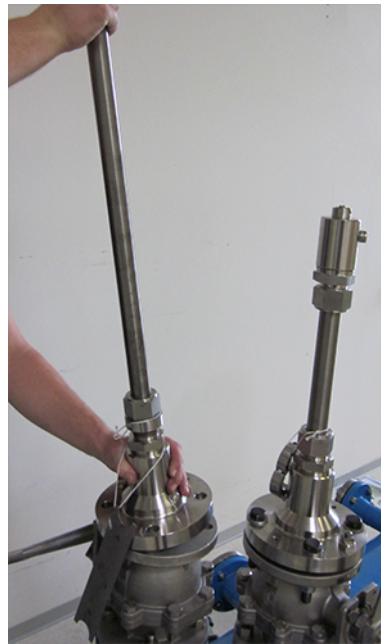

- 9 Remove the graphite seal.
- 10 If applicable, fit a sealing and a blind flange.

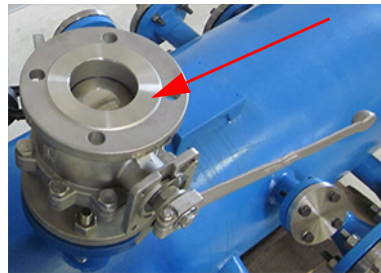
**NOTICE:**

If the sender/receiver units shall be installed again, make sure, the clamping ring stays in the correct position and does not slide back.

FLOWSIC100 Flare

6 Specifications

Technical data
Dimensional drawings

6.1 **Technical data**

Table 2 Technical data FLOWSIC100 Flare 90° Upgrade Kit

	Imperial	Metric
Measured values	Mass flow, volumetric flow s. c., volumetric flow a. c., molecular weight, gas volume and mass, gas velocity, sound velocity	
Measuring medium	Mixtures of hydrocarbons with or without H ₂ content	
Ultrasonic sender/receiver units		
Resolution	0.003 ft/s	0.001 m/s
Measuring ranges	0.1 ft/s ... 295 ft/s	0.03 m/s ... 90 m/s
Rangeability	3000:1	
Nominal pipe size	12" ... 72"	DN300 ... DN1800
Uncertainty of measurement		
Volumetric flow a. c.	≤ 5 % ¹⁾	
Molecular weight	≤ 2 % (in the range 2 ... 120 kg/kmol) ²⁾	
Gas temperature		
Standard	-94 °F ... +356 °F	-70 °C ... +180 °C
High-temperature Zone 1	-94 °F ... +536 °F	-70 °C ... +280 °C
Low-temperature	-320 °F ... +212 °F	-196 °C ... +100 °C
Operating Pressure	-7 psi(g) ... 275 psi(g), full ANSI	-0.5 bar(g) ... 19bar(g), full ANSI
Ambient temperature	-40 °F ... +158 °F	-40 °C ... +70 °C
Ex-approvals (identical with approval of the FLSE100-EXS, also see Operating Instructions FLOWSIC100 Flare)		
NEC/CEC (US/CA)	Cl I, Div1 Group B, C, D T4	
	Ex/AEx d [ia] IIB + H2 T4	
	Cl I, Div2 Group A, B, C, D T4	
	Ex/AEx nA [ia] IIC T4	
ATEX	II 1/2 G Ex d [ia Ga] IIC T4 Ga/Gb	
IECEX	Ex d [ia Ga] IIC T4	
	Optional: temperature class T6	
Enclosure rating	Enclosure type 4 / IP65 / IP67 ³⁾	
MCUP control unit		
Ex-approvals		
NEC/CEC (US/CA)	CSA Cl I, Div1, groups A, B, C, D; T6	
	CSA Cl I, Div2; groups A, B, C, D; T4	
ATEX	II 2 G Ex de IIC T6	
	II 3 G Ex nA II T4	
IECEX	Ex de IIC T6	
Ambient Temperature	-40 °F ... +140 °F ³⁾	-40 °C ... +60 °C ³⁾
Standard Inputs / Outputs	Standard: 1 x Analog Output, 2 x Analog Inputs, 5 x Digital Outputs, 4 x Digital Inputs	Max. if using optional I/O modules: 7 x Analog Outputs, 12 x Analog Inputs, 7 x Digital Outputs, 7 x Digital Inputs
Interfaces		
Service interfaces	USB, RS-232, RS-485, Ethernet RJ-45	
HART p/T reading	Digital Transmitter Interface	
Bus protocol	Modbus, HART, PROFIBUS DP, Foundation Fieldbus (FF)	

1) Of the measured value; in the range 1 to 295 ft/s (0.3 to 90 m/s); for fully developed flow profiles

2) Hydrocarbon mixtures with < 10% of non-hydrocarbonic content

3) Depending on Ex-classification

6.2 Dimensional drawings

Fig. 20 Dimensions [mm] for the sender/receiver units of the FLOWSIC100 Flare 90° Upgrade Kit

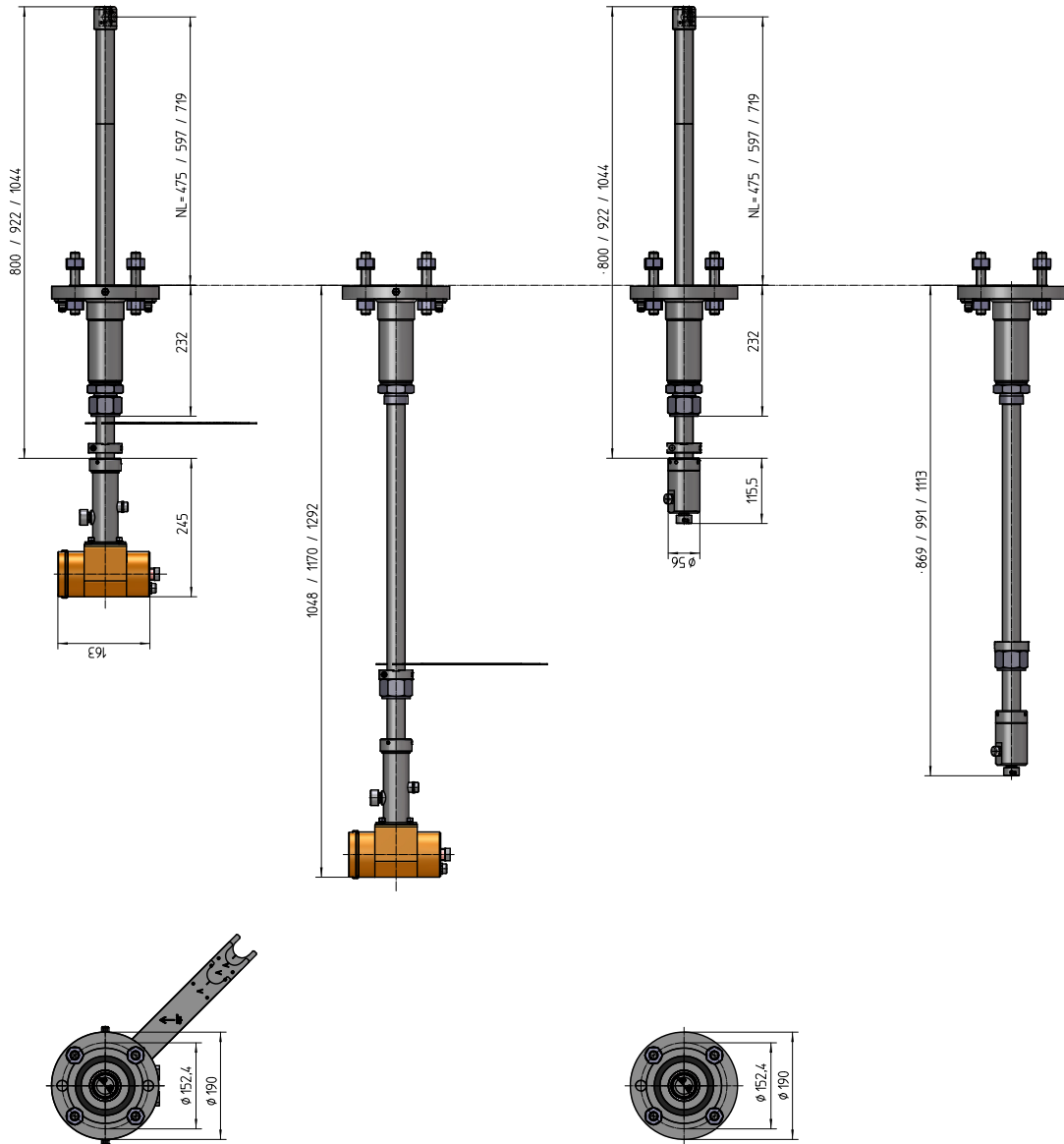
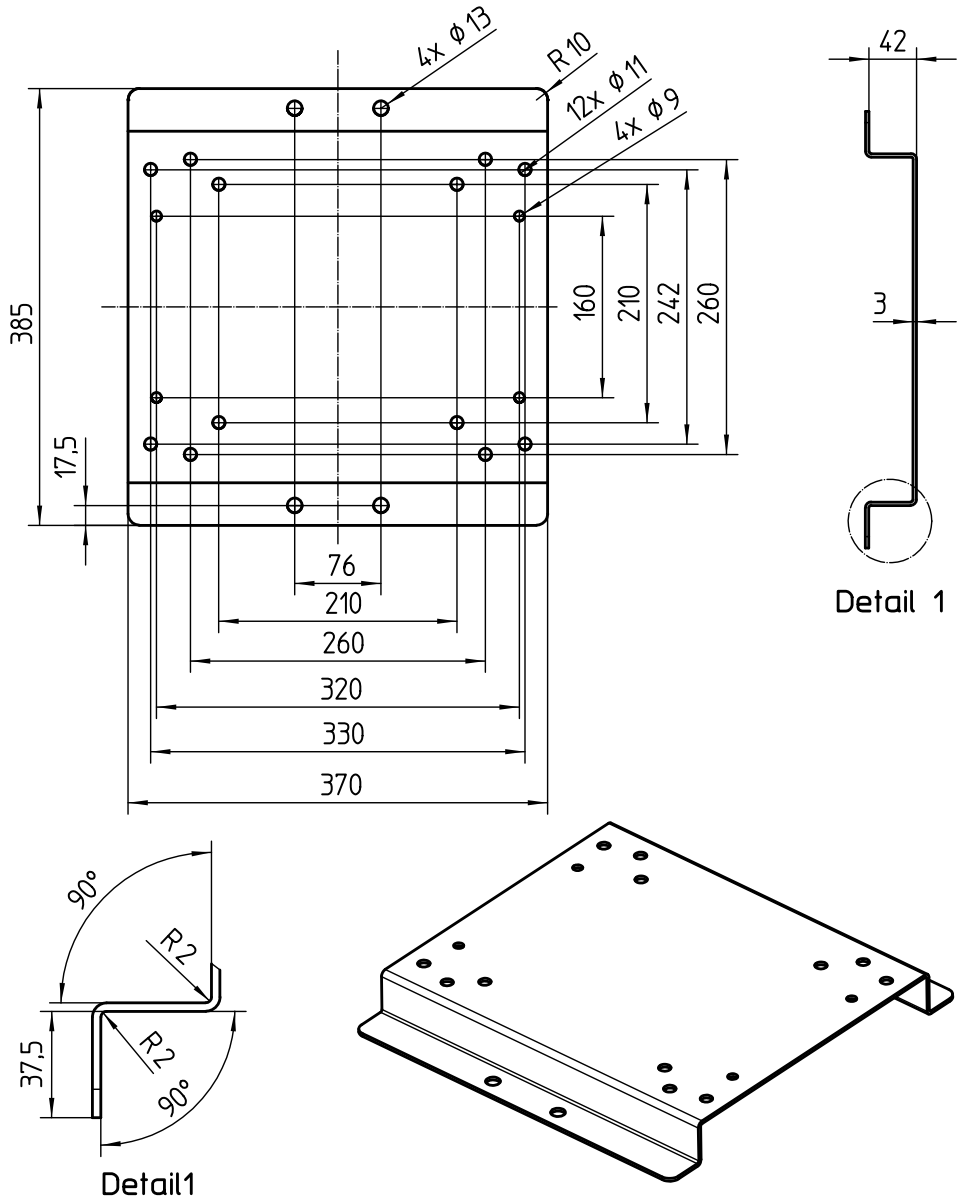

Fig. 21 Dimensions [mm] for the adapter plate



Subject to change without notice

Australia

Phone +61 3 9457 0600
1800 334 802 – tollfree
E-Mail sales@sick.com.au

Austria

Phone +43 (0)22 36 62 28 8-0
E-Mail office@sick.at

Belgium/Luxembourg

Phone +32 (0)2 466 55 66
E-Mail info@sick.be

Brazil

Phone +55 11 3215-4900
E-Mail marketing@sick.com.br

Canada

Phone +1 905 771 14 44
E-Mail information@sick.com

Czech Republic

Phone +420 2 57 91 18 50
E-Mail sick@sick.cz

Chile

Phone +56 2 2274 7430
E-Mail info@schadler.com

China

Phone +86 4000 121 000
E-Mail info.china@sick.net.cn

Denmark

Phone +45 45 82 64 00
E-Mail sick@sick.dk

Finland

Phone +358-9-2515 800
E-Mail sick@sick.fi

France

Phone +33 1 64 62 35 00
E-Mail info@sick.fr

Germany

Phone +49 211 5301-301
E-Mail info@sick.de

Great Britain

Phone +44 (0)1727 831121
E-Mail info@sick.co.uk

Hong Kong

Phone +852 2153 6300
E-Mail ghk@sick.com.hk

Hungary

Phone +36 1 371 2680
E-Mail office@sick.hu

India

Phone +91-22-4033 8333
E-Mail info@sick-india.com

Israel

Phone +972-4-6881000
E-Mail info@sick-sensors.com

Italy

Phone +39 02 27 43 41
E-Mail info@sick.it

Japan

Phone +81 (0)3 5309 2112
E-Mail support@sick.jp

Malaysia

Phone +603 808070425
E-Mail enquiry.my@sick.com

Netherlands

Phone +31 (0)30 229 25 44
E-Mail info@sick.nl

New Zealand

Phone +64 9 415 0459
0800 222 278 – tollfree
E-Mail sales@sick.co.nz

Norway

Phone +47 67 81 50 00
E-Mail sick@sick.no

Poland

Phone +48 22 837 40 50
E-Mail info@sick.pl

Romania

Phone +40 356 171 120
E-Mail office@sick.ro

Russia

Phone +7-495-775-05-30
E-Mail info@sick.ru

Singapore

Phone +65 6744 3732
E-Mail sales.gsg@sick.com

Slovakia

Phone +421 482 901201
E-Mail mail@sick-sk.sk

Slovenia

Phone +386 (0)1-47 69 990
E-Mail office@sick.si

South Africa

Phone +27 11 472 3733
E-Mail info@sickautomation.co.za

South Korea

Phone +82 2 786 6321
E-Mail info@sickkorea.net

Spain

Phone +34 93 480 31 00
E-Mail info@sick.es

Sweden

Phone +46 10 110 10 00
E-Mail info@sick.se

Switzerland

Phone +41 41 619 29 39
E-Mail contact@sick.ch

Taiwan

Phone +886 2 2375-6288
E-Mail sales@sick.com.tw

Thailand

Phone +66 2645 0009
E-Mail tawiwat@sicksgp.com.sg

Turkey

Phone +90 (216) 528 50 00
E-Mail info@sick.com.tr

United Arab Emirates

Phone +971 (0) 4 88 65 878
E-Mail info@sick.ae

USA/Mexico

Phone +1(952) 941-6780
1 (800) 325-7425 – tollfree
E-Mail info@sick.com

Vietnam

Phone +84 8 62920204
E-Mail Ngo.Duy.Linh@sicksgp.com.sg

More representatives and agencies
at www.sick.com