



RFU61x

QUICKSTART

en

1 About this document

The purpose of this Quickstart is to allow you to commission the RFU610-106xx RFID read/write device (UHF) quickly and easily and to achieve initial read results with transponders.

The Quick Start Guide is valid for all the regional radio variants listed: [see Device overview, page 7](#).

In the following, the Quick Start Guide refers to the RFU610-106xx (UHF) RFID read/write device simply as "device". If variants are to be differentiated in the regional assignment, the respective device name RFU610-106xx is specified (xx = regional assignment).

The Quickstart describes the commissioning process for an application with an RFU610-106xx in an ambient temperature range of 0 °C to +50 °C.

Commissioning is carried out as an example for the RFU610-10600 device variant (Ethernet variant, Europe region and other countries if necessary, [see Device overview, page 7](#)). The basis is the basic parameter setting of the device. The optional GL6 photoelectric sensor is used as an example for the industrial-standard read-cycle triggering of the device (part no. 1059241). The photoelectric sensor can be connected with the device as a trigger sensor. Additional trigger sensors can be found at www.sick.com.

All rights reserved. Subject to change without notice.

Supplementary documents

Information, such as application examples and downloads of associated documents (e.g. operating instructions) and software, can be found on the SICK product page on the Internet at: www.sick.com/RFU61x. For an overview [see Sources for obtaining more information, page 7](#) in this Quick Start Guide.

More detailed information on mounting and electrically installing the device as a stand-alone unit than provided in this Quickstart is available in the RFU61x RFID read/write device (UHF) operating instructions. The operating instructions add the following information to the Quick Start Guide:

- Requirements and notes for mounting and electrical installation at operating ambient temperatures below 0 °C
- For applications in widely distributed systems: Notes on the suppression of ground potential equalizing currents

2 Safety information

- This chapter is dedicated to the safety of commissioning personnel and the operator of the system in which the device is integrated.
- Read this Quickstart carefully to familiarize yourself with the device and its functions before commissioning the device. The Quickstart is considered a part of the device and must be kept in an accessible location in the immediate vicinity of the device at all times!

Electromagnetic radiation

WARNING

Health hazard as a result of high-frequency electromagnetic radiation!

The RFU610-10600 (Europa region and possibly other countries) is designed for operation in accordance with ETSI EN 302208. During operation, the human exposure regulations covered by EN 50364 must be observed.

- Limit human exposure to electromagnetic fields. Suitable safety distances must be maintained during both short-term and long-term work in the radiation range of the integrated antenna. Minimum distances to be maintained between the antenna and the human body during long-term transmission: 10 cm and maximum radiation power of the antenna of 100 mW (20 dBm) as per ETSI.

The RFU610-10601 (USA region and possibly other countries) satisfies the limit values of the FCC for exposure to radiation in an uncontrolled environment.

- During operation, a safety distance of at least 20 cm must be maintained between the antenna and the human body.

Complete region assignment of the RFU610-106xx [see Device overview, page 7](#).

Conditions for specified enclosure rating

- To ensure compliance with the IP67 enclosure rating of the device during operation, the following requirements must be met. If these requirements are not met, the device does not fulfill any specified enclosure rating.
 - The joint side cover for the USB interface and the memory card slot is placed against the device and screwed on tight. Recommended tightening torque for the cover screws: 30 Ncm ± 5 Ncm.
 - The cables plugged into the electrical M12 and M8 connections must be screwed tight.

- Any unused M12 and M8 connections must be sealed with screw-on protective caps (for male connectors) or plugs (for female connectors) as supplied.
- Only operate the device without a cover for a short period while inserting or removing the memory card or temporarily using the USB interface. During this time, protect the device against moisture and dust.
- The type label on the lower side of the device contains a pressure equalizing membrane attached in the middle. If the type label is damaged or removed, the leak tightness of the device can no longer be guaranteed.
- Opening the screws of the device housing will invalidate any warranty claims against SICK AG. For further warranty provisions, see the General Terms and Conditions of SICK AG, e.g. on the delivery note of the device.

Standard IP technology

NOTE

SICK uses standard IP technology in its products. The emphasis is placed on availability of products and services.

SICK always assumes the following prerequisites:

- The customer ensures the integrity and confidentiality of the data and rights affected by its own use of the aforementioned products.
- In all cases, the customer implements the appropriate security measures, such as network separation, firewalls, virus protection, and patch management.

2.1 Intended use

The RFU61x RFID read/write device (UHF) is an intelligent ID sensor from the RFU6xx product family. Version (working range): Short Range.

The stationary device automatically identifies wireless-based data cards (transponders) on stationary and moving objects. The device also supports data card management.

The compact read/write device has an (internal) antenna integrated in the housing. The device processes the data of all standard passive transponders in accordance with ISO/IEC 18000-63 and EPCglobal UHF C1G2 in the regional UHF carrier frequency range.

Intelligent process logic enables processing as a stand-alone solution. Network operation is possible for coordinating trouble-free readings of devices at close proximity to one another, but without a coordinating summary of the reading results. The device sends the read results to a higher-level computer (e.g. PLC) via its host interface. The computer coordinates further processing of the data in the process.

The device receives corresponding commands for data card management (write, read, etc.) via its host interface.

Device variants refer to the region assignment, [see Device overview, page 7](#).

NOTE

The device approval was granted for a specific region. The region assignment cannot be changed.

- Only use the device in the region and the country for which it has been approved.
- When reselling the device, inform the buyer of the fixed region assignment.
- Should the device be passed on to a third party, these operating instructions and the Quick Start Guide should be handed over with it.
- For country-specific particulars to consider when operating the device, [see Operational restrictions, page 7](#).

Intended use of the device also includes compliance with all information in this Quickstart and the supplementary RFU61x RFID read/write device (UHF) operating instructions.

3 Device description

3.1 Device view

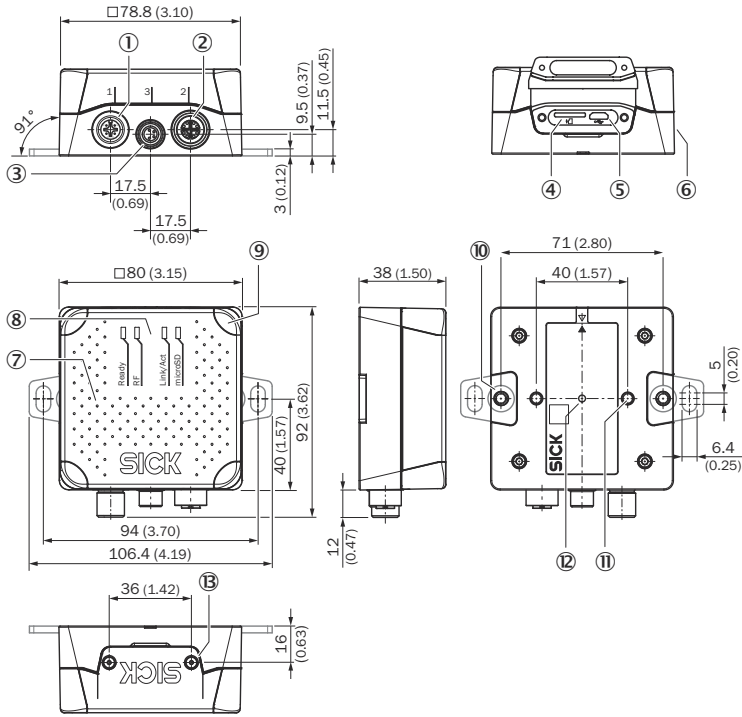
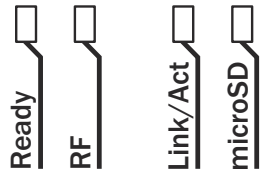

Figure 1: Dimensional drawing of the RFU610-106xx, unit: mm (inch), decimal separator: period

- ① Connection 1: Power (male connector, M12, 4-pin, A-coded)
- ② Connection 2: PoE (female connector, M12, 8-pin, X-coded)
- ③ Connection 3: Trigger (female connector, M8, 4-pin, coded)
- ④ Slot for microSD memory card
- ⑤ "USB" connection (female connector, 5-pin, Micro B type). The USB interface is only for temporary use as a service interface.
- ⑥ Side type label
- ⑦ Optics cover with integrated antenna
- ⑧ 4 x multi-colored LED (status)
- ⑨ 4 x multi-color LED (process feedback)
- ⑩ 2 x M5 threaded mounting holes, 6 mm deep, for attaching the mounting straps
- ⑪ 2 x M5 blind tapped holes, 7 mm deep, for alternative mounting of the device
- ⑫ type label with integrated pressure compensation membrane
- ⑬ 2 x screw (M2,5 socket screw), captive, for side cover

3.2 Status displays



Status displays

Advertisement	LED	Color	Status
Ready	Lights up	Green	The device is ready for use.
	Lights up	Red	The device is not ready for use: hardware fault
	Flashing	Green	PROFINET operation (single port): The LEDs flash cyclically and alternating 4 x red, 1 x green.
	Flashing	Red	The LEDs flash cyclically and alternating 4 x red, 1 x green. <ul style="list-style-type: none"> • The device attempts to establish a connection to a PLC (IO controller) - or - • During operation: the connection between the device and the PLC (IO controller) is interrupted
RF	Lights up	Green	The UHF field is switched on.
	Lights up	Red	Fault: integrated antenna or RF part.
Link/Act	Lights up	Green	Data traffic on the Ethernet interface

Advertisement	LED	Color	Status
microSD	Lights up	Green	The memory card is inserted and ready for operation. <ul style="list-style-type: none"> • In this state, the device can either write data to the memory card or read data on the card. • If the LED lights up, however, this does not indicate that the device is accessing the card!
	Lights up	Red	The memory card is inserted. However, the device cannot read data on the memory card. Possible causes: <ul style="list-style-type: none"> • The memory card does not contain any data • The content is not readable • The memory card is defective
	Lights up	Orange ¹⁾	A function is started with SOPAS ET which requires a memory card for writing. However, the memory card is not connected.

- 1) Prerequisite: In SOPAS ET, the "SD card required" function has been activated under the "Service" user level.

3.3 Memory card (optional accessory)

The device can execute the following functions on the plug-in microSD memory card:

- Cloning function: If a MicroSD memory card is present, the device automatically saves its internal parameter set on the memory card as well. This procedure is carried out in the framework of the recommended storing concept for the device parameter sets. Storing the internal parameter set with the "permanent" option triggers the cloning function. The function is used, among other things, to conveniently transfer the parameter set to an replacement device of the same type in the event of a fault.
- Data logging: The device continuously records read diagnosis data after the first manual start, e.g. via SOPAS ET. If the function is permanently set, the device automatically resumes recording after a restart.

NOTE

Recommendation:

- Use an empty memory card to save a parameter set for the first time. If necessary, check the contents of the card on the PC using a card reader and delete if necessary.

The microSD memory card is not included in the scope of delivery.

Only use types approved by SICK to ensure reliable function of the memory card, see www.sick.com/RFU61x. The memory card has no write protection that can be activated.

Inserting the memory card

NOTE

Possible data loss or irreparable damage to the memory card!

The device does not signal access to the card.

- Only use the memory card when the device power is off.
- Do not remove the memory card or switch off the supply voltage while the following functions are taking place in the device:
 - Storage of parameter values with the SOPAS ET configuration software with the "Permanent" option
 - Functions have been started that access the memory card (e.g. concurrent logging of data)
- To remove the memory card safely during operation, select the **Remove SD card** function under **Analysis/MicroSD memory card** and wait for SOPAS ET to provide confirmation.

The card slot can be accessed on the device behind the plastic foil, see [Device description, page 2](#).

Maintaining enclosure rating IP67: see [Safety information, page 1](#).

1. Switch off the supply voltage to the device.
2. Loosen both screws on the cover.
3. Carefully fold up the cover.
4. Making sure it is in the correct position, insert the memory card into the card slot until it locks into place. When doing so, orient the contacts forwards and downwards as per the symbol on the device.
5. Screw the cover back on. Recommended tightening torque for the cover screws: 30 Ncm ± 5 Ncm.
6. Switch on the supply voltage for the device.
7. Once it is switched on, the device automatically detects the presence of a memory card and, depending on the card's content, behaves as follows:
 - If the memory card is empty or if does not contain a parameter set that can be interpreted by the device: the device saves its currently valid internal parameter set to the card (provided there is sufficient storage space) and starts with the internal parameter set.
 - If the card contains a parameter set that can be interpreted by the device: the device overwrites the currently valid internal parameter set with this external parameter set.
The goal is for the internal parameter set and the parameter set saved externally to always be identical.

4 Mounting

4.1 Scope of delivery

- The device in the version ordered (region assignment). Electrical connections are fitted with protective caps or plugs. Without connecting cables. 2 fixing straps incl. 2 M5 screws are included.
- Printed Quick Start Guide, language versions dependent on region: [see Device overview, page 7](#). Copies in other languages may be available in PDF format on the device product page on the Internet at: www.sick.com/RFU61x.

4.2 Auxiliary equipment required

- 2 x M5 screws for mounting the device on a mounting device (bracket) supplied by the customer. The screw length depends on the mounting base (wall thickness of the bracket).
- When using an optional SICK bracket, the screws for mounting the device on the bracket are included the scope of delivery of the bracket.

4.3 Installation requirements

- The permissible ambient conditions for operating the device must be observed, e.g. assigned radio region: [see Device overview, page 7](#), ambient temperature: [see Technical data, page 6](#) and ground potential: [see Electrical installation, page 3](#).
- The device must be mounted using the 2 M5 blind tapped holes provided, [see Device view, page 2](#).
- If necessary, use stable mounting equipment with sufficient load-bearing capacity and appropriate dimensions for the device. Weight of the device (without cables): [see Technical data, page 6](#), device dimensions: [see Device view, page 2](#).
- Make sure there is no electrically conductive material between transponder and device.

4.4 Mounting the device

1. Select a suitable mounting location for the device. The mounting location and position depend on the antenna field of the device and the transponders used.
2. Perform one of the following steps:
 - a) Mount the device using the 2 mounting straps provided. To do this, screw the supplied M5 screws max. 6 mm deep into the two outer threaded mounting holes on the back of the device, [see Device view, page 2](#).
 - b) Mount the device on the bracket provided by the customer using 2 screws. Screw M5 screws max. 7 mm deep into the two inner threaded mounting holes, [see Device description, page 2](#).
 - c) Mount the device on the SICK mounting accessories ordered separately. Proceed as described under b).
3. Align the surface of the integrated antenna of the device (front face) to the transponder on the object. While doing so, take into account the shape, alignment, and dimensions of the antenna field. Avoid as far as possible any large metal surfaces positioned to the front. If this is not possible, do not mount the antenna plane parallel with the surface.

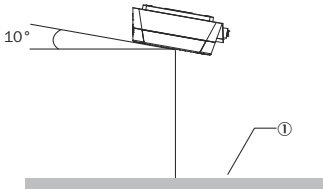

Figure 2: Selection of the approach angle with a large metal surface on the front. e.g., 10°

① Metal surface

4. Ensure there is no electrically conductive material (e.g., metal, liquids) or persons between the device and the transponder during the write or read process. This will absorb or reflect the generated UHF field and thereby reduce the read range.

Read range

The environment influences the UHF field of the integrated antenna, making it impossible to provide a “clear” demarcation of the read range.

- Application-specific reflections can result in both overreaches and “holes”
- Other factors that can significantly impact the read range include:
 - Quality of the transponder: antenna gain, the integrated transponder chip and related sensitivity, reflected energy
 - Material of the carrier object (plastic, wood, metal)
 - Objects between the device and transponder that can affect the UHF field (items, liquids, people)

In addition to the read results, the device can also output diagnostic data. The diagnostic data provides an indication of the write and read quality. This diagnostic data can be used to achieve optimum read results when setting up the system.

The radiation pattern shown here for the device’s antenna was obtained in a reproducible environment (absorber chamber as a reflection-free space) for illustrative purposes. The diagram shows how the UHF field propagates in the reflection-free space, but cannot be used to draw any conclusions on the likely read range in a real application on-site.

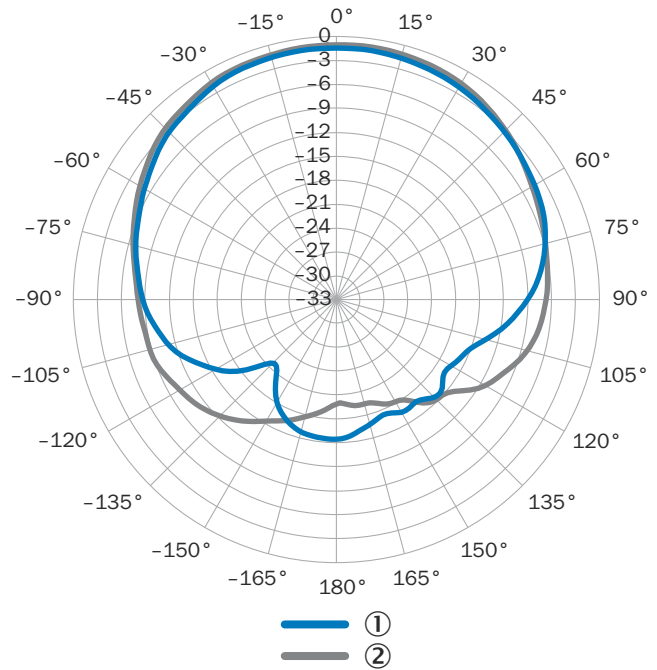

Figure 3: Radiation pattern of the integrated antenna of the RFU61x (typical): Measured antenna gain in dBic at 866.5 MHz, LHCP (left-hand circularly polarized)

- ① Horizontal plane (azimuth)
② Vertical plane (elevation)

5 Electrical installation

- **The electrical installation must only be performed by an electrically qualified person.**
- **Standard safety requirements must be observed when working on electrical systems!**
- Electrical connections between the read/write device and other devices are only allowed to be made or separated in a voltage-free state. Otherwise, there is a risk of damaging the devices.
- When using connecting or extension cables with an open end, make sure that bare wire ends are not touching (risk of short-circuit when the supply voltage is switched on). Wires must be appropriately insulated from each other. This also applies to unused wires.
- Wire cross-sections in the supply cable from the customer’s power system must be designed in accordance with the applicable national standards.
- Connect the device only to the permissible supply voltage, [see Technical data, page 6](#).
- Protect the device with a separate fuse of 0.8 A (slow blowing) at the start of the supply circuit.
- All circuits connected to the device must be designed as ES1 circuits. The voltage supply or power supply unit must satisfy ES1 requirements in accordance with the currently applicable EN 62368-1.

⚠ WARNING

Risk of injury and damage caused by electrical current!

As a result of equipotential bonding currents between the device and other grounded devices in the system, faulty grounding of the device can give rise to the following dangers and faults:

- Dangerous voltages are applied to the metal housings.
- Devices will behave incorrectly or be destroyed.
- Cable shielding will be damaged by overheating and cause cable fires.

Remedial measures

- Only skilled electricians should be permitted to carry out work on the electrical system.
- If the cable insulation is damaged, disconnect the voltage supply immediately and have the damage repaired.
- Ensure that the ground potential is the same at all grounding points.
- Where local conditions do not meet the requirements for a safe earthing method, take appropriate measures (e.g., ensuring low-impedance and current-carrying equipotential bonding).

📌 NOTE

For recommended measures for eliminating hazards, see the “Electrical installation” chapter in the RFU61x RFID read/write device (UHF) operating instructions on the product page on the Internet at www.sick.com/RFU61x

! NOTICE

Risk of damage to the device due to reverse polarity of the supply voltage!

The supply voltage input for the device is designed with internal circuit protection to provide reverse polarity protection. The internal functional earth, which also corresponds to the negative pole of the supply voltage for the device, is connected directly to the metal housing of the device due to reasons relating to high frequency.

If the supply voltage is polarity-reversed, this will not cause any damage provided that the following conditions are met for the device:

The device is not connected in an electrically conductive manner, either via other cables or via its housing, to other peripheral devices which use the same reference potential.

i NOTE

For a more in-depth examination, see the “Electrical installation” chapter in the RFU61x RFID read/write device (UHF) operating instructions on the product page on the Internet at www.sick.com/RFU61x.

5.1 Connecting the device electrically

i NOTE

The USB interface of the device is used in industrial environments only as a service interface for temporary use (e.g. for configuration, troubleshooting). Permanent use in operational use of the system as a host interface is not intended.

Voltage supply

There are two ways to supply the device with voltage, as follows:

1. Power and Ethernet: DC 18 V ... 30 V
 - Connection 1: power (DC 24 V)
 - Connection 2: Ethernet or PoE
2. Power over Ethernet (PoE): DC 48 V / 57 V according to PoE technology
 - Connection 1: not assigned
 - Connection 2: PoE

i NOTE

The voltage supply via a power supply unit must be capable of bridging a brief power failure of 20 ms.

Both variants can be combined. Recommendation: select only one variant.

Connecting connection variants at the same time

Initial situation	Adjustment	Effect
Voltage supply power via connection 1	Additionally, PoE connected via connection 2.	No effect on the device status.
Voltage supply PoE via connection 2	Additionally, power connected via connection 1.	No effect on the device status. Voltage supply with immediate effect via power via connection 1 (dominant).
Voltage supply power via connection 1 (dominant) and PoE via connection 2	Connecting power via connection 1 is isolated.	Device restarts. Voltage supply with immediate effect via PoE via connection 2.

After successful initialization, the Ready LED illuminates green.

Trigger

Read and write commands for the device can be started and ended using a trigger sensor. A trigger sensor can be connected directly to the device (connection 3). The permanently active supply voltage is received by the trigger sensor from the device. If connection 3 is not used, provide the female connector with a protective plug. Additional information, see [Technical data, page 6](#).

Connection 3: trigger

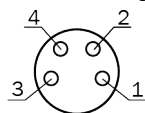

Figure 4: Female connector, M8, 4-pin, coded

Pin assignment of the “Trigger” connection

Pin	Signal	Function
1	V _S Trigger	Trigger supply voltage
2	NC	NC
3	GND	Functional ground
4	Sensor 1	Digital input

i NOTE

The numbering of the data interfaces (Aux 1, etc.) in the following block diagrams provides a better overview, but is not shown in configuration tools such as the SOPAS ET configuration software.

5.1.1 RFU610-106xx: Power and Ethernet

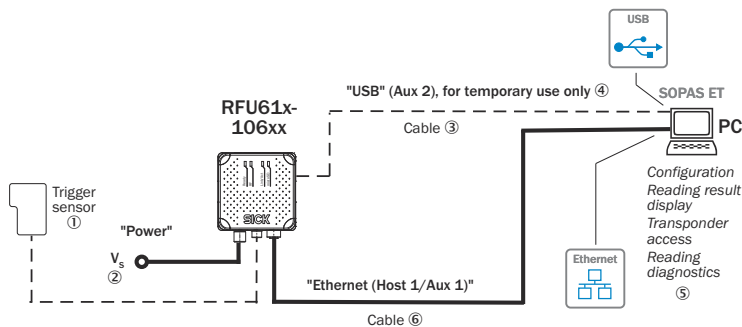

- ① Trigger sensor for external read cycle (optional)
- ② Supply voltage V_S
- ③ Adapter cable (male connector, USB, Micro-B type/male connector, USB, type A)
- ④ USB, alternative to Ethernet Aux port. The USB interface is only for temporary use as a service interface.
- ⑤ Configuration with SOPAS ET, prepared representation of the read result, transponder access or reading diagnostics
- ⑥ Adapter cable (male connector, M12, 8-pin, X-coded/male connector, RJ-45, 8-pin)

1. Connect connection 1 via a power adapter cable (e.g. part no. 2095607) directly to a supply voltage.
2. Connect connection 2 via a Ethernet adapter cable (e.g. part no. 6049728) directly to a PC.
3. Connect the trigger sensor (e.g. GL6 [part no. 1059241]) via a trigger adapter cable (e.g. part no. 2096347) directly to connection 3 of the device.

Connection 1: power

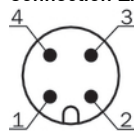

Figure 5: Male connector, M12, 4-pin, A-coded

Pin assignment of the “Power” connection

Pin	Signal	Function
1	V _S	Supply voltage
2	NC	NC
3	GND_ext	Primary ground
4	NC	NC

Connection 2: Ethernet

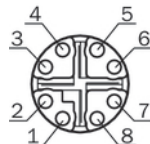

Figure 6: Female connector, M12, 8-pin, X-coded

Pin assignment of the “Ethernet” connection

Pin	Signal	Function
1	TD+	Sender+
2	TD-	Sender-
3	RD+	Receiver+
4	RD-	Receiver-
5	PoE-	Supply voltage-
6	PoE-	Supply voltage-
7	PoE+	Supply voltage+
8	PoE+	Supply voltage+

5.1.2 RFU610-106xx: Power over Ethernet (PoE)

RFU610-106xx (PoE connection)

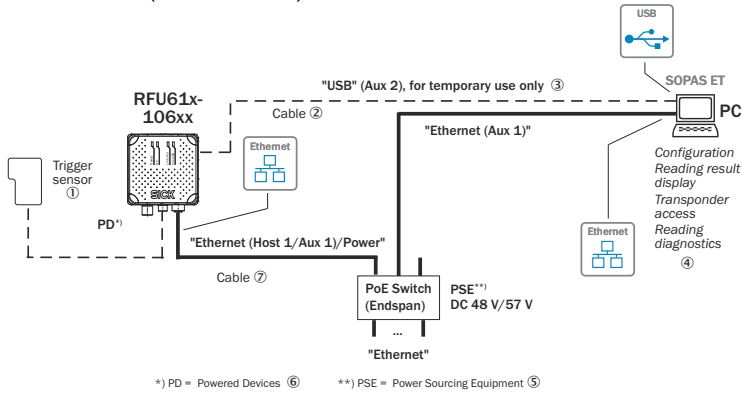

- *) PD = Powered Devices (6) **) PSE = Power Sourcing Equipment (5)
- ① Trigger sensor for external read cycle (optional)
 - ② Adapter cable (male connector, USB, Micro-B type/male connector, USB, type A)
 - ③ USB, alternative to Ethernet Aux port. The USB interface is only for temporary use as a service interface.
 - ④ Configuration with SOPAS ET, prepared representation of the read result, transponder access or reading diagnostics
 - ⑤ PSE = Energy source
 - ⑥ PD = Energy consumer
 - ⑦ Adapter cable (male connector, M12, 8-pin, X-coded/male connector, RJ-45, 8-pin)
1. Connect connection 2 via a PoE adapter cable (e.g. part no. 6049728) directly with a PoE switch or PoE injector.
 2. Connect the trigger sensor (e.g. GL6 [part no. 1059241]) via a trigger adapter cable (e.g. 2096347) directly to connection 3 of the device.

Connection 2: PoE

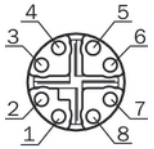

Figure 7: Female connector, M12, 8-pin, X-coded

Pin assignment of the "PoE" connection

Pin	Signal	Function
1	TD+	Sender+
2	TD-	Sender-
3	RD+	Receiver+
4	RD-	Receiver-
5	PoE-	Supply voltage-
6	PoE-	Supply voltage-
7	PoE+	Supply voltage+
8	PoE+	Supply voltage+

6 Commissioning and configuration with computer (Windows PC)

Adaptation of the device parameters to the application as well as diagnostics in the event of malfunctions take place as default with the SOPAS ET configuration software.

6.1 Installing and starting the configuration software

1. Download and install the latest version of the SOPAS ET configuration software, as well as the current device description files (*.sdd): www.sick.com/SOPAS_ET. In this case, select the "Complete" option as suggested by the installation wizard. Administrator rights may be required on the computer (PC) to install the software.
2. Start the "SOPAS ET" program option after completing the installation. Path: Start > Programs > SICK > SOPAS ET Engineering Tool > SOPAS.
3. Establish communication between SOPAS ET and device with the automatically launching wizard. To do so, select the RFU610-106xx under the devices available depending on the connected communication interface, e.g. in the Ethernet (default Ethernet address: IP address: 192.168.0.1, subnet mask: 255.255.255.0). SOPAS ET establishes communication with the device and loads the associated device description file. The **Quickstart** tab opens.

6.2 Detecting a transponder in Quickstart mode

1. Bring one or more standards-compliant UHF transponders into the working range of the integrated antenna of the device. The UII/EPC of the individual transponders must be differentiated so that the device can detect several transponders.
2. Click the **Start** button on the **Quickstart** tab of SOPAS ET. SOPAS ET generates an automated read cycle and lists the detected transponders one after another in the Quickstart window.

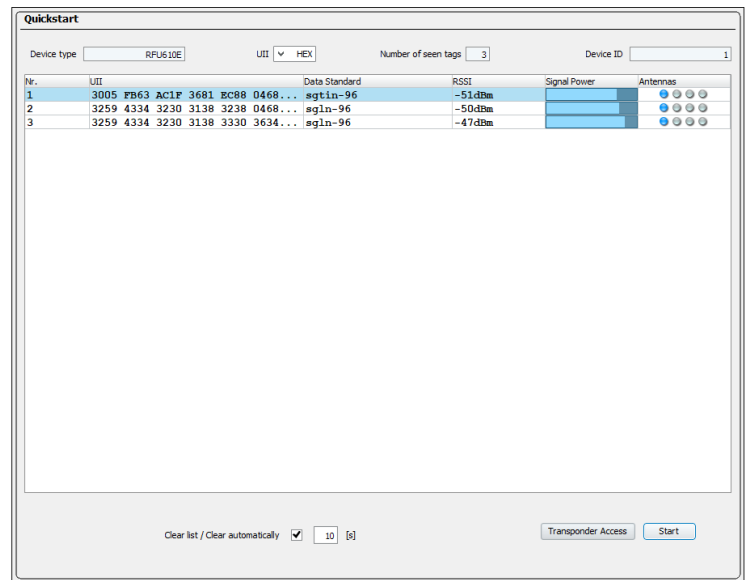

Figure 8: SOPAS ET display of the detected transponders in the **Quickstart** window

Feedback about transponder detection in the UHF field

In Quickstart mode, the default lighting behavior of the process feedback LEDs indicates whether a UHF field is present and whether the device has detected transponders. The process feedback LEDs are located in the four corners of the antenna cover and light up blue in this case. Choose between two brightness levels in SOPAS ET to adjust the brightness of the process feedback LEDs.

Process feedback LEDs

LED status	Status
Lit up (permanently)	No transponder in field
Flashing slowly (f = 1.25 Hz)	1 transponder in field
Flashing quickly (f = 2.5 Hz)	2 transponders in field
Flashing faster (f = 5 Hz)	More than 2 transponders in field

NOTE

Quickstart mode is not intended to be used during normal operation. For operational use, set a read cycle using the object trigger control in SOPAS ET.

6.3 Accessing the data on a transponder

1. In order to access the memory area of a transponder, click the **Stop** button in **Quickstart**.
2. Highlight the desired transponder (click it with the mouse).
3. Click the **Transponder Access** button. The **Transponder Management Access** tab displays the content of the selected transponder.

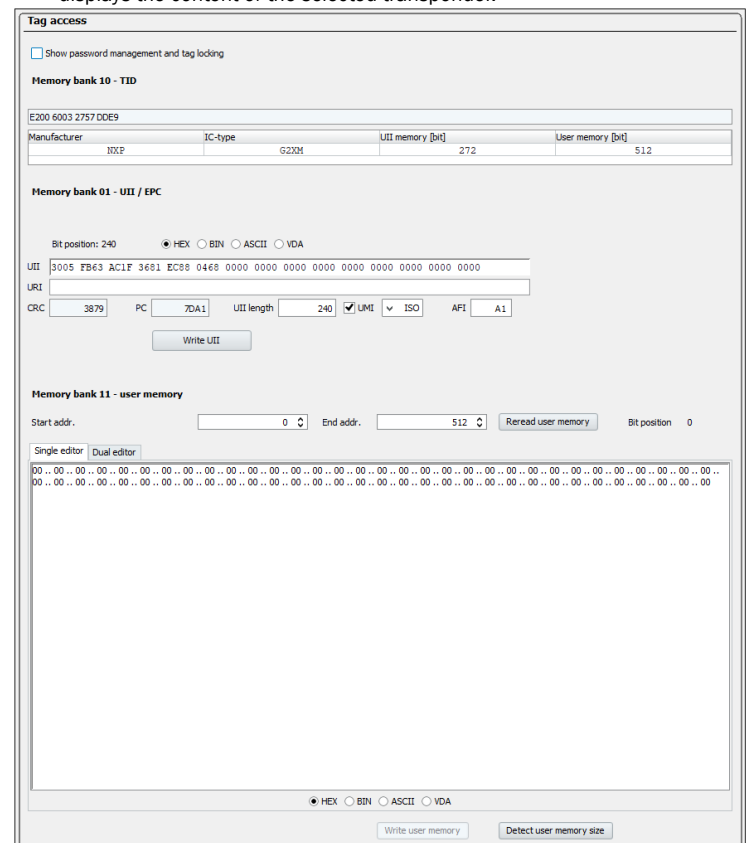

Figure 9: SOPAS ET: **Transponder Access** display window

NOTE
The device cannot write the TID (tag identifier) of the transponder.

6.4 Continuing the configuration

- Under SOPAS ET in the left-hand navigation tree, edit the required tabs for the application using the additional entries under **Parameters**. These include amongst others:
 - antenna configuration, performance optimization, data pre-processing, transponder processing
 - Object trigger control (e.g. via digital input "Sensor 1"), data processing and output
 - Data output interface(s), function of the digital input and use of an optional memory card if necessary.
- Set the transmitting power for the integrated antenna using sliders on the **Antenna Configuration** tab.
 - Regional permissible values for the antenna, see [Device overview, page 7](#).
 - Transmitting power default RFU610-106xx: 10 dBm (10 mW)

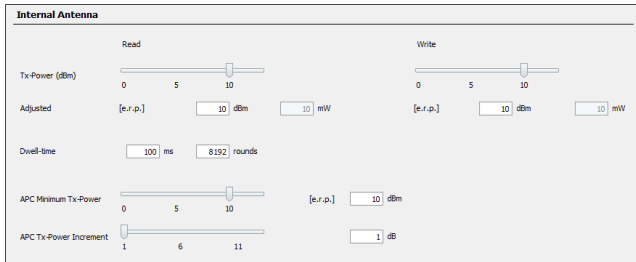



Figure 10: SOPAS ET: Example setting for the integrated antenna

- Test and, if necessary, modify the settings made during operational use of the system.

6.5 Completing the configuration

- Permanently save the entire configuration once it has been successfully tested:
 - Parameter set in the device: Click the button .
 - Configuration file on the PC: Click buttons **Device** > **Export SDV** file.

7 Maintenance and care

The device does not contain components that require maintenance.

- If it is contaminated (e.g. metal dust), clean the front of the device (antenna hood) carefully using a soft, damp cloth (with a mild cleaning agent) in order to achieve the full read and write speed. The antenna hood is made of plastic.

8 Transport and storage

Transport and store the device in the original packaging, with protective plugs and caps completely screwed-on. Do not store outdoors. To ensure that any residual moisture present can escape, do not store the device in airtight containers. Do not expose to any aggressive substances.

Storage conditions: dry, dust-free, no direct or indirect sunlight, as little vibration as possible. Storage temperature and relative humidity see [Technical data, page 6](#).

9 Repairs

Repair work on the device may only be performed by qualified and authorized service personnel from SICK AG.

10 Disassembly and disposal

Any device which can no longer be used must be disposed of in an environmentally friendly manner in accordance with the applicable national waste disposal regulations. As it is categorized as electronic waste, the device must never be disposed of with household waste!

11 Technical data

11.1 Features

	RFU610-106xx
Version (working range)	Short range
Product category	RFID read/write device (UHF) with integrated antenna
Frequency band	UHF (860 MHz ... 960 MHz)
Radio equipment approval (regional assignment)	Depending on type, see Device overview, page 7
Carrier frequency	
Transmitting power	
RFID standard (air interface)	EPCglobal UHF Class 1 Generation 2, ISO/IEC 18000-6 C
Modulation	PR-ASK
Connection type	Power and Ethernet or PoE

	RFU610-106xx
Read range	Typically: 0.5 m ¹⁾
Antenna	Integrated antenna <ul style="list-style-type: none"> Transmitting power: adjustable Polarization: circular (LHCP ²⁾) Axis behavior: typically 2 dB (ETSI), 3 dB (FCC) Aperture angle: 110° Front-to-back ratio: typically > 5 dB
Service functions	Semi-automated saving of parameter data (parameter cloning) outside the device memory: <ul style="list-style-type: none"> Using insertable microSD memory card ³⁾ in the device
Clock	Network time protocol (NTP), no internal clock
Conformities	Depending on type. See type-specific online data sheet at: www.sick.com/RFU61x UL: RFU610-10601 (USA and Canada) ⁴⁾
Certificates	Depending on type. See "Downloads" section online at: www.sick.com/RFU61x

- The read range depends on the transponder used and the ambient conditions.
- LHCP = left-hand circular polarization.
- Optional accessories.
- UL-certified if the type label contains the UL logo and the UL conditions are met during device operation.

11.2 Interfaces

	RFU610-106xx
Ethernet	<ul style="list-style-type: none"> Protocol: TCP/IP Function: host (data output of the read result) Function: Aux (service) ¹⁾ Data transmission rate 10/100 Mbit/s Services: DHCP, NTP, HTTP/HTTPS
PROFINET	<ul style="list-style-type: none"> Protocol: PROFINET Function: host (data output of read result), PROFINET Single Port ²⁾ Data transmission rate 10/100 Mbit/s
EtherNet/IP™	<ul style="list-style-type: none"> Protocol: EtherNet/IP™ Function: host (data output of the read result) Data transmission rate 10/100 Mbit/s
USB 2.0 ³⁾	<ul style="list-style-type: none"> Function: Aux (service) ¹⁾
Digital input	<ul style="list-style-type: none"> Version: physical, switching $V_{in}^{4)} = \max. 30 \text{ V}$, $I_{in}^{5)} = \max. 5 \text{ mA}$. $V_{S_Trigger}^{6)} = V_S$, $I_{S_Trigger}^{7)} = \max. 40 \text{ mA}$ Debounce time: adjustable ⁸⁾ A corresponding trigger sensor (e.g. GL 6) can be connected directly
Optical indicators	<ul style="list-style-type: none"> 4 RGB LEDs (status indicators) on front top 4 x RGB LEDs (process feedback) in the four corners of the antenna cover. Display function can be set with pre-defined color assignment ⁸⁾.
Configuration	SOPAS ET configuration software, CoLa commands (telegrams), web server, fieldbus controller (PLC) with additional support by SICK function blocks
Programming	Application-specific programming with SICK AppStudio ⁹⁾ development environment. You can find further information on the Internet at: www.sick.com/SICK_AppStudio

- Service: e.g. configuration, diagnosis, transponder access or prepared representation of the read result.
- Function blocks for PLC types from different manufacturers are available online at: www.sick.com/RFU61x.
- USB interface only for temporary use (servicing).
- Input voltage.
- Input current.
- Supply voltage for external trigger sensor.
- Supply current for external trigger sensor.
- For example using the SOPAS ET configuration software.
- This functionality can be unlocked with the SDK6U SD card. Available online at: www.sick.com

11.3 Mechanics and electronics

	RFU610-106xx
Electrical connection	<ul style="list-style-type: none"> Connection 1: male connector, M12, 4-pin, A-coded Connection 2: female connector, M12, 8-pin, X-coded Connection 3: female connector, M8, 4-pin, coded USB interface: female connector, 5-pin, Micro B type
Supply voltage V_S	ES1 according to EN 62368-1, NEC protection class 2 (UL13010) <ul style="list-style-type: none"> Power and Ethernet: DC 18 V ... 30 V PoE: DC 48 V / 57 V according to PoE technology

	RFU610-106xx
Power consumption	<ul style="list-style-type: none"> • Operation: 6 W typical ¹⁾ • Standby: 3 W typical
Housing	Cast aluminum, plastic (PPS)
Housing color	Black, silver
Side cover	Plastic foil, can be opened for temporary access to USB interface and memory card slot
MTBF	22 years ²⁾
Enclosure rating	IP67 (EN 60529:1991-10/A2:2000-02)
Protection class	III (EN 61140:2006-08)
Safety	EN 62368-1:2014
Weight	Approx. 313 g
Dimensions (L x W x H)	92 mm x 80 mm x 38 mm ³⁾

- 1) At full transmitting power.
- 2) Continuous operation at an ambient operating temperature of +50 °C.
- 3) With any protruding connection or fastening elements, see [Device view, page 2](#).

11.4 Ambient data

	RFU610-106xx
Electromagnetic compatibility (EMC)	EN 301489-1 V2.1.1 (2017) EN 301489-3 V1.6.1 (2013)
Vibration resistance	IEC 60068-2-6:2007 (10 Hz ... 150 Hz / 5 g sine) IEC 60068-2-64: 2008 (10 Hz ... 500 Hz / 3.5 g RMS)
Shock resistance	IEC 60068-2-27:2008 (30 g / 6 ms / 12 shocks per axis/half sine and 25 g / 6 ms / 200 shocks per axis/half sine)
Ambient temperature	<ul style="list-style-type: none"> • Operation: -25 °C ... +50 °C • Storage ¹⁾: -40 °C ... +70 °C
Permissible relative humidity	0% ... 90%, non-condensing

- 1) Storage conditions see [Transport and storage, page 6](#).

12 Device overview

RFU610-106xx: Device overview

Regional assignment	Firmware from version	Carrier frequency	Transmitting power of the integrated antenna	Device type	Part no.	Supplied Quickstarts (part no.)
Europe/ South Africa/ United Arab Emirates	V2.06	865.7 MHz ... 867.5 MHz	Max. 25 mW (ERP ¹⁾)	RFU610-10600	1091102	English (8023832), German (8024099)
USA/ Canada/ Mexico	V2.06	902.75 MHz ... 927.25 MHz	Max. 40 mW (EIRP ²⁾)	RFU610-10601	1099890	English (8023832), French (8024100), Spanish (8024101)
India	V2.07	865.7 MHz ... 866.9 MHz	Max. 25 mW (ERP ¹⁾)	RFU610-10603	1104443	English (8023832)
Brazil	V2.08	902.75 MHz ... 907.25 MHz 915.25 MHz ... 927.25 MHz	Max. 40 mW (EIRP ²⁾)	RFU610-10604	1104444	English (8023832), Portuguese (8024106)
China	V2.07	902.625 MHz ... 924.375 MHz	Max. 25 mW (ERP ¹⁾)	RFU610-10605	1101394	English (8023832), Chinese (8024104)
Japan	V2.07	916.8 MHz ... 920.4 MHz	Max. 40 mW (EIRP ²⁾)	RFU610-10607	1104447	English (8023832), Japanese (8024103)
Singapore	V2.08	920.25 MHz ... 924.75 MHz	Max. 25 mW (ERP ¹⁾)	RFU610-10609	1104449	English (8023832)
Korea	V2.08	917.3 MHz ... 920.3 MHz	Max. 40 mW (EIRP ²⁾)	RFU610-10610	1104446	English (8023832) Korean (8024102)
Taiwan	V2.08	922.25 MHz ... 927.75 MHz	Max. 40 mW (EIRP ²⁾)	RFU610-10613	1104445	English (8023832) Taiwanese (8024105)
Malaysia	V2.08	919.25 MHz ... 922.75 MHz	Max. 25 mW (ERP ¹⁾)	RFU610-10614	1104441	English (8023832)
Vietnam	V2.08	918.25 MHz ... 922.75 MHz	Max. 40 mW (EIRP ²⁾)	RFU610-10618	1104448	English (8023832)

- 1) ERP = equivalent radiated power.
- 2) EIRP = equivalent isotropic radiated power.

12.1 Operational restrictions

! NOTICE

Operational restrictions!

Depending on its type, the RFU610-106xx is configured in its frequency band so that it corresponds to the respective region-dependent specifications. The relevant settings cannot be changed.

Without interfering with nationally protected frequencies (e.g. mobile radio), the device can be operated in the following assigned regions depending on the type, see [Device overview, page 7](#) "Device type" and "Regional assignment" column.

Operating the same RFU610-106xx in other regions can interfere with protected frequencies.

- Only use the RFU610-106xx in the region for which a certification is available.
- When reselling the RFU610-106xx, inform the buyer that the regional assignment cannot be changed.

France

The RFU610-106xx must not be operated within a 20 km radius of 13 military zones.

Lithuania

There may be restrictions in Lithuania (extent not currently known).

USA

(1) This device complies with part 15 of the FCC Rules. Operation is subject to the following two conditions:

(1) This device may not cause harmful interference, and (2) this device must accept any interference received, including interference that may cause undesired operation.

(2) Changes or modifications not expressly approved by the party responsible for compliance could void the user's authority to operate the equipment.

(3) Note: This equipment has been tested and found to comply with the limits for a Class A digital device, pursuant to part 15 of the FCC Rules. These limits are designed to provide reasonable protection against harmful interference when the equipment is operated in a commercial environment. This equipment generates, uses, and can radiate radio frequency energy and, if not installed and used in accordance with the instruction manual, may cause harmful interference to radio communications. Operation of this equipment in a residential area is likely to cause harmful interference in which case the user will be required to correct the interference at his own expense.

(4) To comply with FCC part 15 rules in the United States, the system must be professionally installed to ensure compliance with the Part 15 certification.

(5) It is the responsibility of the operator and professional installer to ensure that only certified systems are deployed in the United States. The use of the system in any other combination (such as co-located antennas transmitting the same information) is expressly forbidden.

(6) This device complies with the limit values defined by the FCC for radio radiation in an uncontrolled environment. The device must have a minimum distance of 20 cm between the source of radiation and your body.

Canada

(1) This Class A digital apparatus complies with Canadian ICES-003.

(2) This device satisfies the Industry Canada CNR applicable to license-free radio equipment. Use is permitted providing the two following conditions are met: (1) The device must not cause any faults and (2) the user of the device must accept any fault produced in the device, even if this may impair its function.

Korea

Class A Equipment (Industrial Use)

This device (Class A, EMC) is designed for industrial environments. As the seller and user, please observe this requirement and do not use in household applications!

Taiwan

Warning: For already-certified radio frequency devices with low power, the frequencies must not be changed, the power increased nor the properties and functions of the original design changed by companies or users without permission. The use of radio frequency devices with low power must not impair flight safety nor disturb legal communication; if faults are identified, use must be terminated immediately and improvements must be made until no more faults are present before further use is permissible. Legal communication from the previous point refers to radio communication carried out in accordance with the regulations of the Telecommunications Act. Radio frequency devices with low power must tolerate faults caused by legal communication and industrial, scientific and medical devices and systems which emit radio waves.

13 Sources for obtaining more information

Additional information about the device, its optional accessories, and fieldbus modules can be found in electronic format on the following product pages on the Internet at:

13.1 RFID read/write device RFU610 (UHF)

www.sick.com/RFU61x

Ordering information

- Device and its regional radio variants
- Compatible accessories, including transponders, cables, brackets, trigger sensors

Documentation

- Online data sheet: summary of type-specific technical data including dimensional drawing for the selected device
- Quickstart RFID read/write device RFU610 (UHF)

- RFID read/write device operating instructions RFU61x (UHF)
- Technical information RFU parameters to support the configuration of the device
- Dimensional drawing and 3D CAD dimension models of the device in various electronic formats
- On request: Overview of the command strings of the device
- Documentation of accessories (mounting systems)

Certificates

- EU declaration of conformity and further certificates

Software

- SOPAS ET configuration software
- SDD files (device description files for SOPAS ET)
- Function blocks for communication between a programmable logic controller (PLC) from different manufacturers and the device or the fieldbus modules.

Support is also available from your sales partner: www.sick.com

13.2 Copyright notices

Open source programs

SICK uses open-source software in the device. This software is licensed by the rights holders using the following licenses among others: the free licenses GNU General Public License (GPL Version2, GPL Version3) and GNU Lesser General Public License (LGPL), the MIT license, zLib license, and the licenses derived from the BSD license.

This program is provided for general use, but WITHOUT ANY WARRANTY OF ANY KIND. This warranty disclaimer also extends to the implicit assurance of marketability or suitability of the program for a particular purpose.

More details can be found in the GNU General Public License.

View the complete license texts here: www.sick.com/licenses/texts

Printed copies of the license texts are also available on request.