

Low Pressure Differential Pressure Gauges Type A2G-10, air2guide

WIKA Datasheet A2G-10

air2guide

Applications

- For dry, clean, non-aggressive gases, air
- Monitoring of blowers and ventilators
- Filter monitoring via differential pressure
- Positive overpressure in clean rooms
- Positive and negative pressure in isolation chambers

Product Features

- Zero adjustment in front
- Simple mounting and dismounting
- Two part construction (measuring element and case)
- Scale ranges from 0.2 InWC (50 Pa) to 50 InWC (12,500 Pa)



Differential Pressure Gauge Model A2G-10

Specifications

Design

Per EN 837-3 and HVAC regulations

Nominal size

4½"

Accuracy

± 3.0 % of full span

± 5.0 % of full span, ranges ≤ 0.5 InWC (125 Pa)

Ranges

0 / 0.2 InWC (50 Pa) up to 0 / 50 InWC (12,500 Pa)

Pressure units

InWc (standard)

Other available units: kPa, Pa, mmWC, cmWC, mmHg

Compound ranges

Starting from -0.1 / +0.1 InWC (-25/+25 Pa)

(other pressure units and dual scales are available)

Pressure limitation

Steady: full-scale value

Fluctuating: full-scale value

Overpressure Safety

80 InWC (20 kPa)

Max working pressure (static pressure)

80 InWC (20 kPa)

Temperature limits

Ambient: -22 °F... 176 °F (-30 °C... +80 °C)

Media: 3 °F...122 °F (-16 °C... +50 °C)

Temperature error

Additional error when temperature changes from reference temperature of 68 °F (20 °C) ± 0.5% of span for every 18 °F (10 °K) rising or falling

Ingress protection

NEMA 3 (IP 54 per EN 60529 / IEC 529)

Standard version

Process connection

Plastic

Lower mount (LM) or back mount G 1/8 female for hose connector

Supplied with straight or angled hose barb adaptors 1/8"-3/16" (standard). 1/4" hose barb adaptors available

Separating diaphragm

Silicone rubber

Movement

Frictionless magnetic transmission

Dial

Aluminium, scale over 90°.

Pointer

Plastic, black

Housing/Mounting case

Black thermoplastic, high impact resistant

Window

Polycarbonate

Options

- Ingress protection, NEMA 4 (IP 65)
- Red mark pointer
- Internationally recognized traceable calibration certificate
- Measuring hose PVC or silicone, inner diameter 4 or 6 mm, length 25 m PVC or silicone tube 1/8" or 1/4" inside diameter
- 2 duct connectors
- Output signal 4... 20 mA, 2-wire, power supply DC 14 V or output signal 0...10 V, 3-wire, power supply DC 15V (see datasheet A2G-15)
- Without mounting case

Dimensions (inches)

Standard version

Surface mount, lower connection

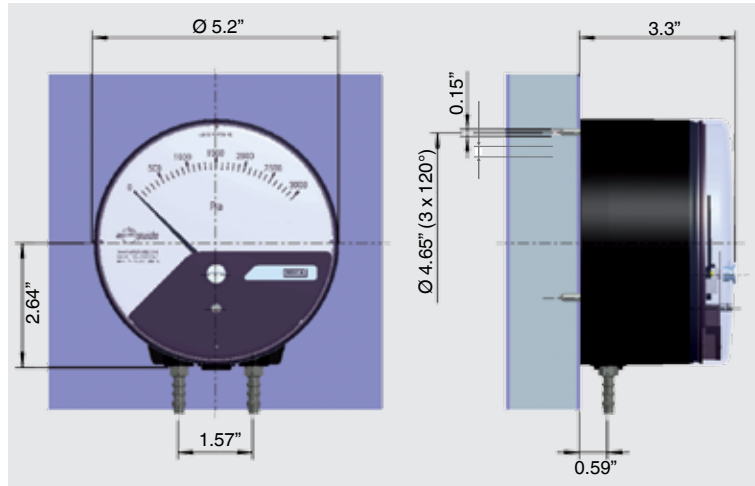

Panel mount, back connection

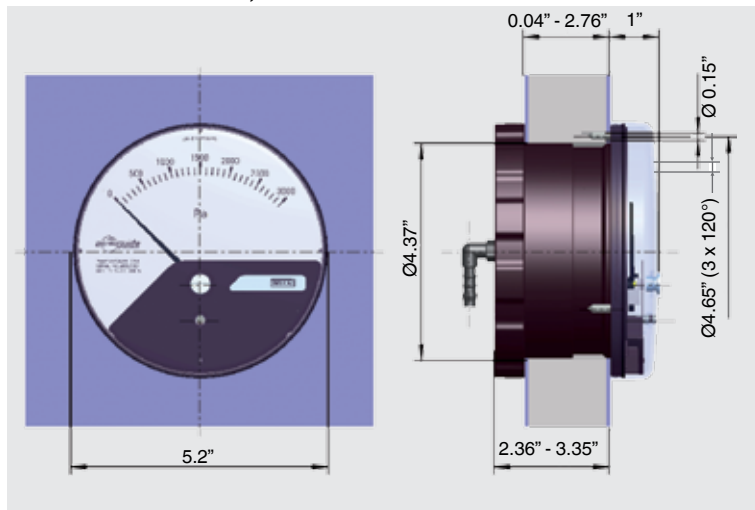

1) Mounting for wall thickness from 0.04 to 2.76"

Ordering information

Model / Connection location / Wall mount or panel mount / Inner dimensions of the threaded pressure connection / Scale range / Options

Ordering information

Pressure gauge model / Nominal size / Scale range / Size of connection / Optional extras required
Specifications and dimensions given in this leaflet represent the state of engineering at the time of printing.
Modifications may take place and materials specified may be replaced by others without prior notice.

