

# Visionary-B

3D SNAPSHOT – TWO-EYES PRINCIPLE FOR EFFECTIVE USE OUTDOORS

3D vision

**SICK**  
Sensor Intelligence.

The Visionary-B from SICK is a rugged 3D vision sensor for industrial applications. It is ideally suited for use in outdoor environments, e.g., in ports, on construction sites, or in agriculture. With intelligent functions for object detection and classification, the Visionary-B can be used as a plug and play solution for driver assistance. The acquired object information as well as 2D and 3D raw data can be made available to other applications via an Ethernet interface.

### Visionary-B variants

The Visionary-B CV from SICK is a driver assistance system for active 3D collision warning on industrial vehicles. The system can be quickly and easily retrofitted. The Visionary-B PS is particularly suitable for application developers aiming to solve a wide variety of outdoor applications using streaming data.

#### Visionary-B CV

- Plug and play driver assistance system for industrial vehicles
- Visible and audible warning signal for improved collision warning through active object detection and classification
- Easy configuration via a monitor (HMI)



#### Visionary-B PS

- Smart 3D streaming camera for outdoor applications
- 3D and 2D raw data as well as output of class and position of relevant objects via Ethernet
- Programming interface for Windows and Linux systems



# SMART 3D SNAPSHOT CAMERA FOR HARSH OUTDOOR ENVIRONMENTS



## Smart object classification

The Visionary-B from SICK uses intelligent algorithms to detect and classify objects in the vicinity of the vehicle. The 3D snapshot technology not only allows to evaluate the width and height of the objects but also their shape. The intelligent algorithms also filter out information about the surroundings that are irrelevant to the operator, for example rain, fog or unevenness in the ground. The relevant information can be outputted as a live image on the monitor or integrated straightforwardly into an independent application via the Ethernet interface.

## Flexible use

The Visionary-B allows to stream the complete raw data as well as the application-specific evaluated data. It can therefore serve as a smart streaming camera or as a turnkey driver assistance solution. Suitable product variants and kits are available for the respective application. The electrical and mechanical accessories included in the delivery make installation much easier. In the case of the Visionary-B CV, the detection zones, and the sensor and vehicle parameters can be configured directly via the supplied monitor. The Visionary-B PS can be flexibly and easily integrated using the comprehensive C++ programming interface for Windows and Linux systems. The Visionary-B from SICK is extremely rugged and reliable thanks to its ambient operating temperature range from  $-40\text{ }^{\circ}\text{C}$  to  $75\text{ }^{\circ}\text{C}$ , and the IP69K enclosure rating of the housing.

# THE PRINCIPLE OF OPERATION

The Visionary-B is based on the stereoscopic principle. It takes two images of each object from slightly varying perspectives. These two slightly different images are used to calculate depth information, i.e. the third dimension. The principle of operation is comparable to human spatial vision: The sensor head captures raw 3D data, and the evaluation unit is programmed – in a similar way to the brain – to analyze and process what the sensor head has seen. This principle of operation makes the advanced Visionary-B from SICK especially suitable as a 3D camera system for outdoor applications.

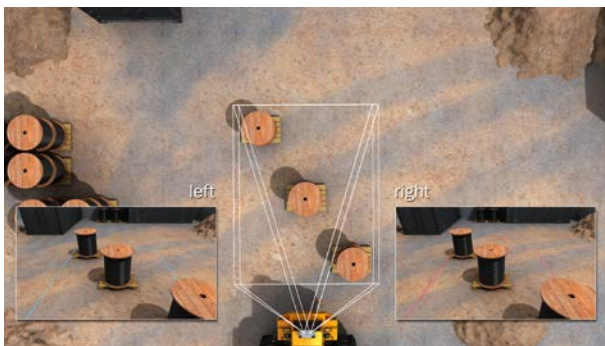

Step one: Two images from slightly different perspectives

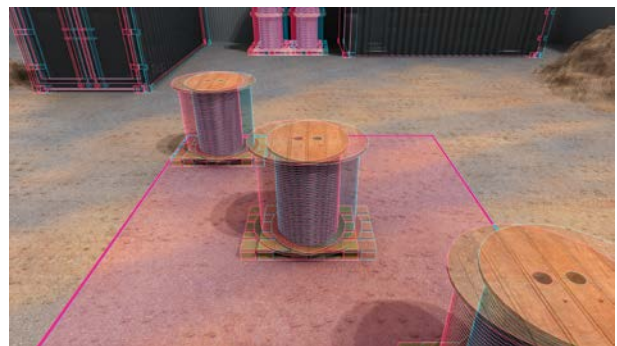

Step two: The two images are superimposed on one another

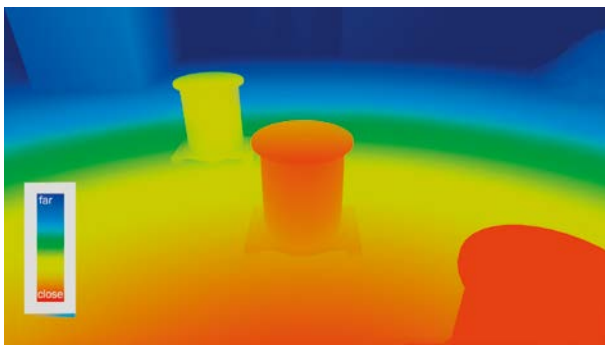

Step three: An image with depth information is created

# THE DATA

## Object classification

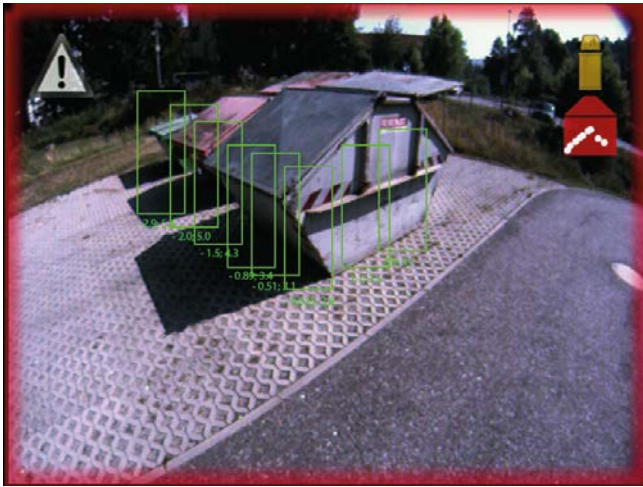

Thanks to the flexible configuration options available, the Visionary-B can reliably detect a variety of object classes. For example it can either detect all objects or, if desired, ignore certain objects such as walls or small objects. This ensures optimal and efficient collision warning. Object classes and positions can be simultaneously outputted via the Ethernet interface and thereby integrated into custom applications.

## Raw data for outdoor applications

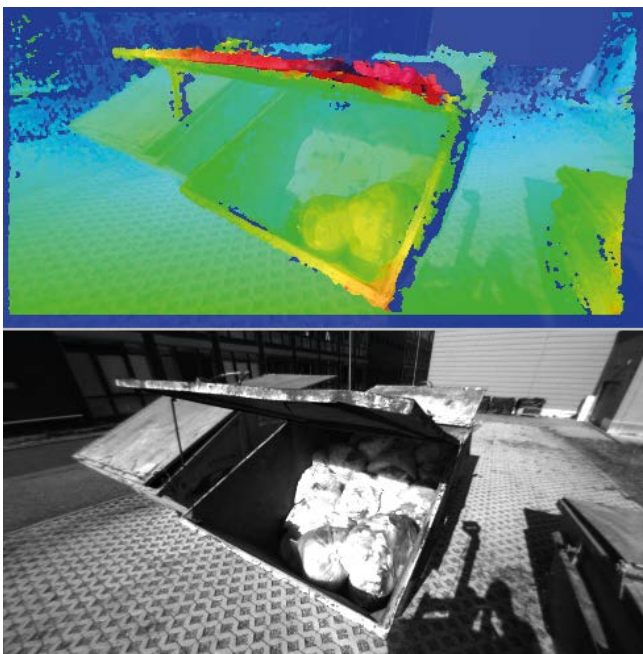

Not only the object data but also the 2D and 3D raw data can be obtained via the Ethernet interface of the Visionary-B. Thanks to the supplied programming interface, these data can be used to solve customer-specific applications. The provided programming examples make it easier to get started.

# MORE FLEXIBLE AND RUGGED APPLICATIONS



- ① 2-in-1: Active 3D sensor and 2D camera.
- ② Sensor head: the detection angle of 120° x 75° perfectly covers blind spots behind the vehicle at a length of 7 m and a width of 6 m.
- ③ Sensor head housing: very stable for use in outdoor environments, IP69K enclosure rating, operating temperature range from -40° C to 75° C.
- ④ Evaluation unit: compact dimensions, powerful, continuous and reliable algorithmic evaluation, stores several hours of the most recent video recordings, Ethernet interface.
- ⑤ Evaluation unit housing: rugged, IP67 enclosure rating, operating temperature range from -40 °C to +50 °C.
- ⑥ Additional output for discrete warning signal.
- ⑦ For Visionary-B CV: Monitor for configuring detection areas, sensor and vehicle parameters, and to display objects in 2D. Visual and audible alarm when the predefined 3D detection zone is breached.
- ⑧ For Visionary-B PS: Ethernet cable for transferring the streaming data.

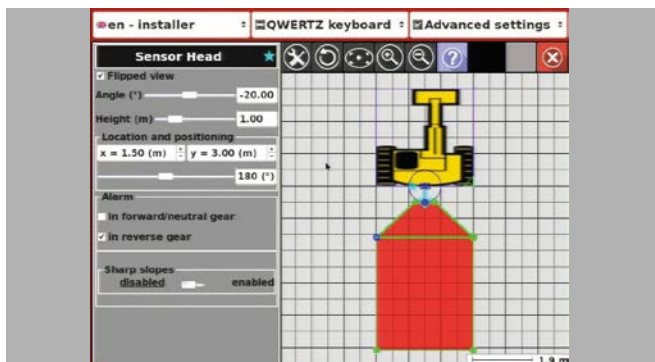

Easy configuration via an HMI

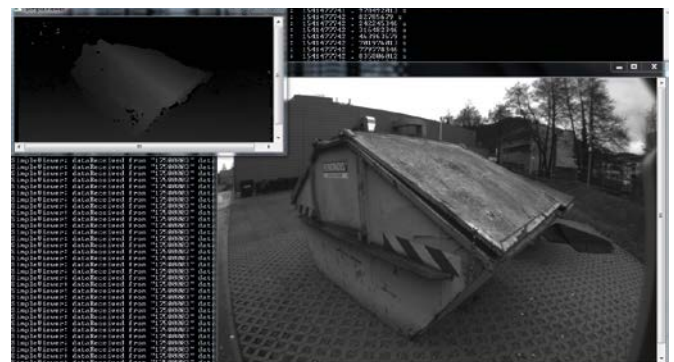

Visualization of the raw data using the supplied programming examples

# APPLICATIONS

Applications and possible uses of the Visionary-B:

## Ports and cranes



- Guided container picking
- Presence detection
- Driver assistance and collision warning

## Construction sites

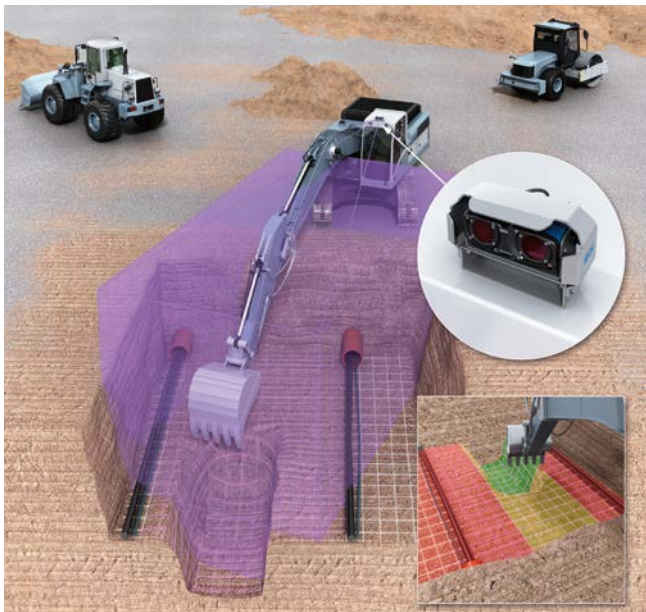

- Support with 3D site management
- Support during excavation
- Driver assistance and collision warning
- Object and vehicle monitoring

## Mining

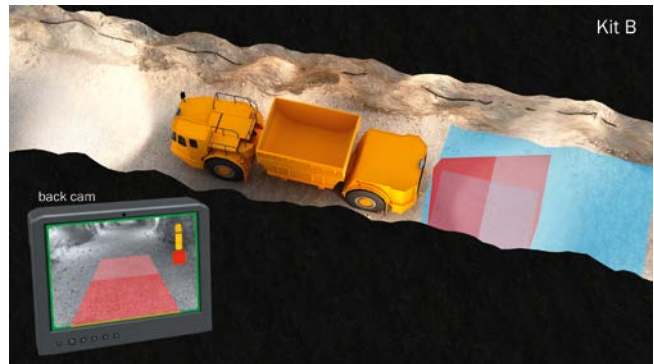

- Driver assistance and collision warning
- Automated steering

## Agriculture and forestry

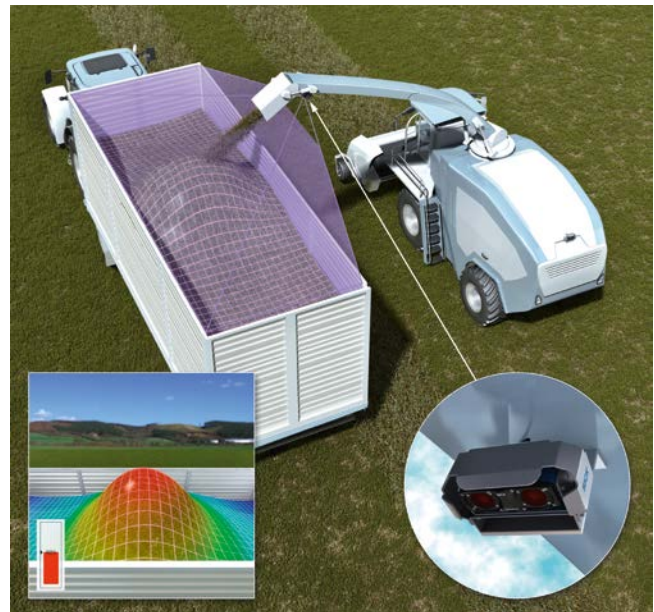

- Level monitoring
- Line guidance
- Windrow detection
- Driver assistance and collision warning

# 3D TECHNOLOGY FOR DRIVER ASSISTANCE SYSTEMS ON MOBILE MACHINES

Mobile machines and specialized vehicles, for example wheel loaders, reach stackers, excavators and combine harvesters, are used indispensably and in all weather conditions on construction sites, by mining companies, at ports, in the forestry and agricultural sector, and in similar environments. The Visionary-B from SICK: a rugged 3D vision sensor with snapshot technology that helps the operators of these machines to avoid collisions and accidents while carrying out frequent maneuvering and reversing operations. The 3D camera does so by detecting relevant objects in difficult to see areas around the vehicle and generating live images that appear on the monitor. The driver assistance system also warns the driver of possible collisions in critical driving situations by means of visual and acoustic signals. A plug and play solution, the Visionary-B is easy to configure and operate, and is ready for use in a matter of moments.

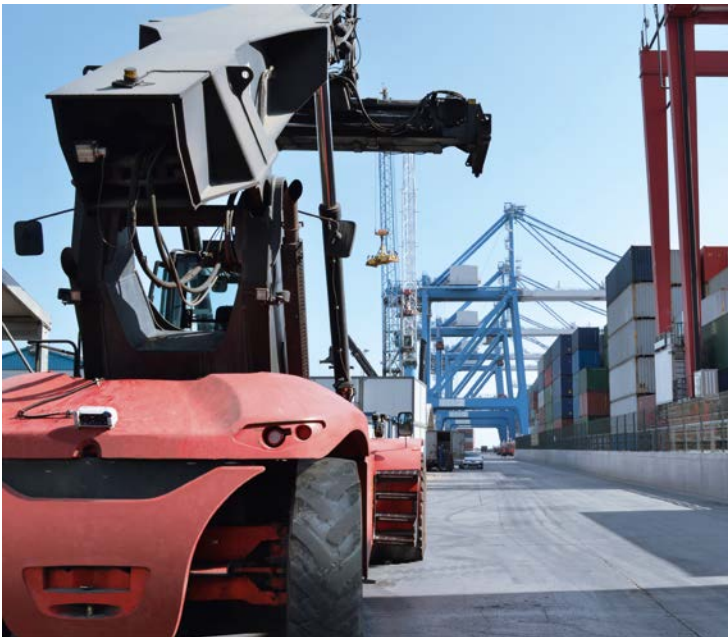

Operators of mobile machines generally have to manage several tasks simultaneously – and often for hours on end. The actual driving and maneuvering of the machine may even take a back seat under certain circumstances. To reduce the burden on the driver and to avoid collisions while performing these tasks, in particular during backward maneuvers, the Visionary-B supports with 3D technology, that is able to detect

objects and obstacles. This means the operator no longer needs to constantly concentrate on their monitor, as is the case with conventional passive camera systems. The Visionary-B lets him focus on the key tasks while still maintaining awareness of critical situations whenever they occur.



### Snapshot technology using the two-eye principle

The Visionary-B records objects around the vehicle with two images from slightly different perspectives. These two slightly different images are used to calculate information about the depth, which represents the third dimension. The principle of operation is similar to the way humans perceive space. Using this two-eye principle, the sensor head captures raw 3D data and transmits it to the evaluation unit which is programmed to analyze the vehicle's environment and warn the operator only in the event of critical situations. SICK's integral data evaluation unit reliably detects five object classes in an outdoor environment. The first class consists of smaller objects than those that make up the second class. Wide objects, such as walls, do not fall into the second class and are ignored for the purposes of this class. Configuring the system to only warn the driver about class 2 objects is an ideal solution in narrow passages, for example, as it will prevent unnecessary and irritating warning signals from being issued. The sensor works as a stand-alone solution and also includes an integrated recording function, which can be used for permanent data recording.

### Making the blind spot visible again

The dimensions of mobile machines and specialized vehicles often result in blind spots directly behind the vehicle that need to be made visible to the operator. To cater for different requirements, several variants, known as kits, are available in design A, B, or C. Kit A, which comprises a sensor head, evaluation unit, monitor, and suitable mounting accessories, fulfills this task with utmost efficiency. When equipping a wider vehicle, or when one sensor is not sufficient due to the geometry of the vehicle, kit C is recommended. Kit B is used if you wish to make the areas both in front of and behind the vehicle visible. It comprises two sensor heads, a monitor, and an evaluation unit that switches between the sensor heads as required. To ensure the driver assistance system only triggers a warning in truly critical situations, it is possible to variably configure the detection zones. Matching the detection zone to the vehicle width ensures no unnecessary warnings are given, such as when driving through narrow passages.

SICK's Visionary-B kits are an indispensable aid for operators of mobile machines or specialized vehicles who need to concentrate more on their main task rather than just on the driving.

For more information and documentation on the Visionary-B, visit: [www.sick.com/Visionary-B](http://www.sick.com/Visionary-B)



# 3D SNAPSHOT – TWO-EYES PRINCIPLE FOR EFFECTIVE USE OUTDOORS

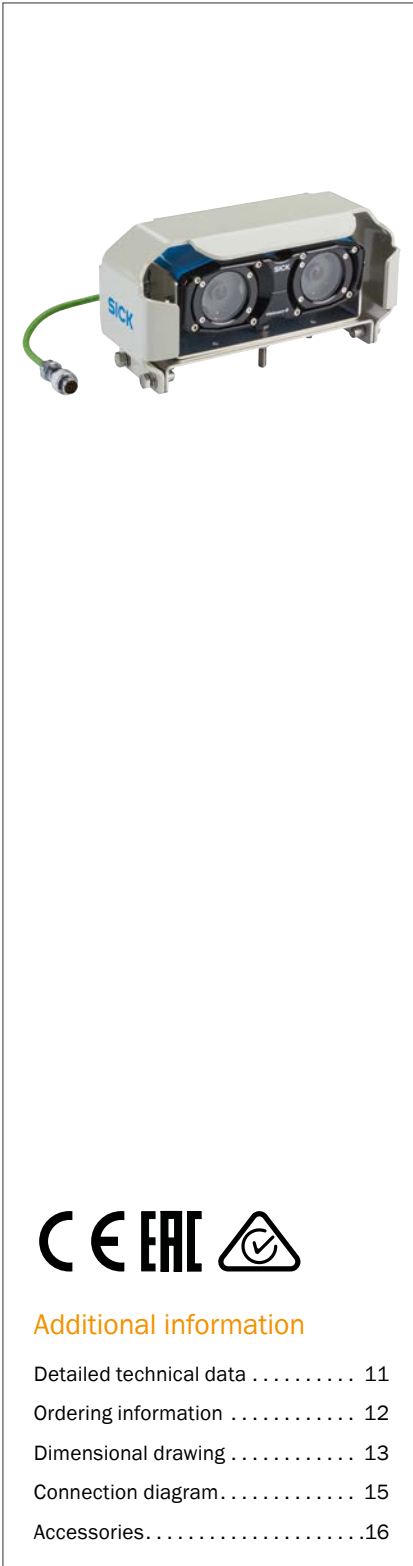

## Product description

Thanks to the innovative 3D snapshot technology and its rugged mechanical design, the Visionary-B 3D vision sensor from SICK is ideally suited for harsh outdoor environments, e.g., ports, construction sites, or in agriculture. The Visionary-B uses the stereoscopic principle to deliver both 2D images and 3D data with every snapshot. Depending on the application, all the raw data and

the intelligent image processing results can be transferred in the form of object classifications and position determinations. As a driver assistance system with a monitor and live image, Visionary-B provides a rugged, easily configurable 3D collision warning system that is quickly operational and actively warns the driver, acoustically and visually, in critical situations.

## At a glance

- Distance values: 250 × 496 pixels and 2D image: 544 × 828 pixels
- High temperature range from -40 °C to +75 °C
- Rugged housing: IP69K for the sensor head
- 2-in-1 solution: eight 3D and eight 2D images per second
- Intelligent image processing: classification and position determination of objects
- Activity recording for the most recent hours possible

## Your benefits

- More than 120,000 distance and intensity values in just a single recording
- Designed for harsh outdoor conditions, e.g., strong sunlight, rain
- Intelligent data processing with object detection and classification allows, for example, object tracking and collision warning
- Visionary-B PS provides 3D data, 2D video images and object data via Gigabit Ethernet as well as a programming interface
- Visionary-B CV is an intelligent, easily configurable 3D driver assistance system with a monitor for the driver's cab that outputs active optical and acoustic warnings



## Additional information

Detailed technical data . . . . . 11  
 Ordering information . . . . . 12  
 Dimensional drawing . . . . . 13  
 Connection diagram . . . . . 15  
 Accessories . . . . . 16

→ [www.sick.com/Visionary-B](http://www.sick.com/Visionary-B)

For more information, simply enter the link or scan the QR code and get direct access to technical data, CAD design models, operating instructions, software, application examples, and much more.



## Detailed technical data

## Features

	Visionary-B PS	Visionary-B CV
<b>Task</b>	Smart streaming camera for use in harsh outdoor environments	3D driver assistance system for collision warning in harsh outdoor environments
<b>Technology</b>	3D-snapshot, image analysis	
<b>Product category</b>	Streaming devices, configurable devices	
<b>Working distance</b>	0.5 m ... 72 m	0.5 m ... 7 m
<b>Detection angle</b>	120° x 75°	
<b>Detection zone</b>	6 m x 7 m for standard configuration	
<b>Further functions</b>	2D camera integrated	

## Performance

	Visionary-B PS	Visionary-B CV
<b>Detectable object shape</b>	See documentation	See HMI and operating instruction
<b>On delay</b>	< 50 s	
<b>Response time</b>	< 200 ms <sup>1)</sup>	
<b>Integrated application</b>	2D and 3D data stream, object classification and position determination	3D driver assistance system for collision warning outdoors, image capturing option integrated

<sup>1)</sup> Typical.

## Interfaces

	Visionary-B PS	Visionary-B CV
<b>Configuration software</b>	API (C++)	Via provided monitor

## Mechanics/electronics

	Visionary-B PS	Visionary-B CV
<b>Connections</b>	1 x USB (reserved) 2 x sensor head Monitor (reserved) Additional alarm output, two discrete outputs (reserved) Machine-to-machine interface (reserved) Ethernet Evaluation unit supply	1 x USB (mouse and keyboard) 2 x sensor head Monitor (VGA/sound) Additional alarm output; two discrete outputs Machine-to-machine interface (reserved) Ethernet (reserved) Evaluation unit supply
<b>Supply voltage</b>	12 V DC, - 10 % 24 V DC, 40 %	12 V DC, - 10 % 24 V DC, 40 % <sup>1)</sup>
<b>Power consumption</b>	≤ 30 W	≤ 30 W Kit A ≤ 35 W Kit B ≤ 60 W Kit C (depending on type)
<b>Enclosure rating</b>	IP69K sensor head IP67 evaluation unit	
<b>Weight</b>	1.3 kg <sup>2)</sup> 3.8 kg <sup>3)</sup>	
<b>Mounting</b>	Choice of height; for optimal object classification 1 m ... 2.4 m, angle according to the detection zone	Height 1 m ... 2.4 m, angle according to the detection zone

<sup>1)</sup> Ensure harmonic-free supply voltage.

<sup>2)</sup> Sensor head.

<sup>3)</sup> Evaluation unit.

	Visionary-B PS	Visionary-B CV
<b>Output current</b>	-	12 V 100 mA (max. overcurrent protection 430 mA)

<sup>1)</sup> Ensure harmonic-free supply voltage.

<sup>2)</sup> Sensor head.

<sup>3)</sup> Evaluation unit.

### Ambient data

<b>Electromagnetic compatibility (EMC)</b>	EN 55016-2-3:2010 + A1:2011 + A2:2014 (interference immunity) / EN 55012:2008-06 + A1:2009 (radiated emission)
<b>Fulfilled standards</b>	ISO 13766:2006-05 (earth-moving machinery), EN 12895:2015-09 (industrial trucks), EN 13309:2010-09 (construction machinery), ISO 14982:2009-02 (agricultural and forestry machinery), ISO 7637-2:2011-03, ISO 16750-2:2012-11, ISO16001:2017, EN 62311:2008, FCC PART 15:2006-08
<b>Shock load</b>	EN 60068-2-29:1994-01 (50 g / 6 ms)
<b>Vibration load</b>	EN 60068-2-64:2008-11 (5,9 g / 10 Hz - 2 kHz)
<b>Ambient operating temperature</b>	-40 °C ... +75 °C, sensor head -40 °C ... +50 °C, evaluation unit
<b>Light sensitivity</b>	200 lx ... 80,000 lx

### Ordering information

- **Further functions:** 2D camera integrated
- **Enclosure rating:** IP69K sensor head, IP67 evaluation unit

Product	Description	Type	Part number
Visionary-B PS	1 x sensor head 1 x evaluation unit Assembly accessories	V3S173-2AAAAAP01	1096019
Visionary-B CV, kit A (standard)	1 x sensor head 1 x evaluation unit 1 x 7" monitor Assembly accessories	V3S153-2AAAAAP01	1091804
Visionary-B CV, kit A (IP67 monitor)	1 x sensor head 1 x evaluation unit 1 x IP67, 8" monitor Assembly accessories	V3S153-2AAAAAP01	1091805
Visionary-B CV, kit A (color sensor head)	1 x color sensor head 1 x evaluation unit 1 x 7" monitor Assembly accessories	V3S153-2BAAAAAP01	1091806
Visionary-B CV, kit A (IP67 monitor & color sensor head)	1 x color sensor head 1 x evaluation unit 1 x IP67, 8" monitor Assembly accessories	V3S153-2BAAAAAP01	1091807
Visionary-B CV, kit B (standard)	2 x sensor head 1 x evaluation unit 1 x 7" monitor Assembly accessories	V3S153-2AAAAAP02	1091808
Visionary-B CV, kit B (IP67 monitor)	2 x sensor head 1 x evaluation unit 1 x IP67, 8" monitor Assembly accessories	V3S153-2AAAAAP02	1091809
Visionary-B CV, kit B (color sensor head)	2 x color sensor head 1 x evaluation unit 1 x 7" monitor Assembly accessories	V3S153-2BAAAAAP02	1091810
Visionary-B CV, kit B (IP67 monitor & color sensor head)	2 x color sensor head 1 x evaluation unit 1 x IP67, 8" monitor Assembly accessories	V3S153-2BAAAAAP02	1091811

Product	Description	Type	Part number
Visionary-B CV, kit C (standard)	2 x sensor head 2 x evaluation unit 2 x 7" monitor Assembly accessories	V3S153-2AAAAAP03	1091812
Visionary-B CV, kit C (IP67 monitor)	2 x sensor head 2 x evaluation unit 2 x IP67, 8" monitor Assembly accessories	V3S153-2AAAAABP03	1091813
Visionary-B CV, kit C (color sensor head)	2 x color sensor head 2 x evaluation unit 2 x 7" monitor Assembly accessories	V3S153-2BAAAAAP03	1091814
Visionary-B CV, kit C (IP67 monitor & color sensor head)	2 x color sensor head 2 x evaluation unit 2 x IP67, 8" monitor Assembly accessories	V3S153-2BAAAAABP03	1091815

**Dimensional drawing** (Dimensions in mm [inch])

Detection volumes and 2D measuring ranges

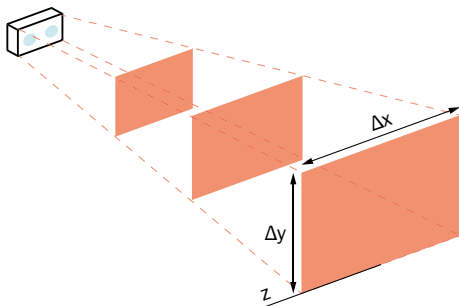

Working distance absolute (z)	Measuring range ( $\Delta x$ )	Measuring range ( $\Delta y$ )	2D image pixel size (x × y)
0.5 m	1.73 m	0.77 m	2 mm × 1 mm
1.0 m	3.46 m	1.53 m	4 mm × 3 mm
1.5 m	5.20 m	2.30 m	6 mm × 4 mm
2.0 m	6.93 m	3.07 m	8 mm × 6 mm
3.0 m	10.39 m	4.60 m	13 mm × 8 mm
4.0 m	13.86 m	6.14 m	17 mm × 11 mm
5.0 m	17.32 m	7.67 m	21 mm × 14 mm
10.0 m	34.64 m	15.35 m	42 mm × 28 mm
15.0 m	51.96 m	23.02 m	63 mm × 42 mm
20.0 m	69.28 m	30.69 m	84 mm × 56 mm
40.0 m	138.56 m	61.39 m	167 mm × 113 mm

Sensor head

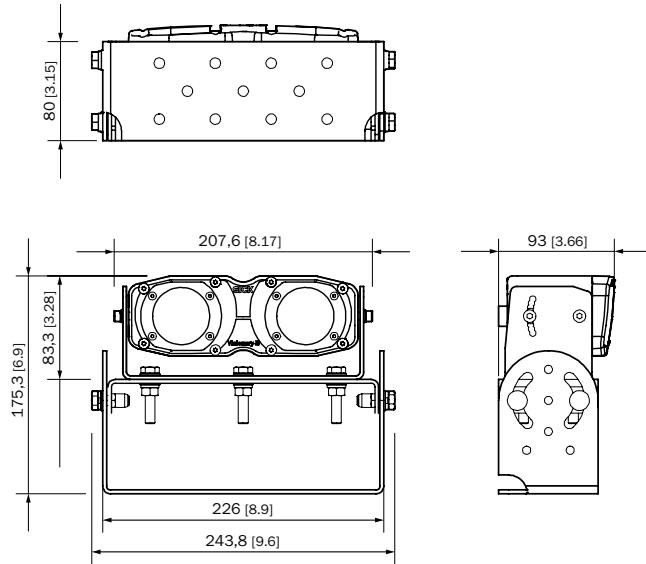

Evaluation unit

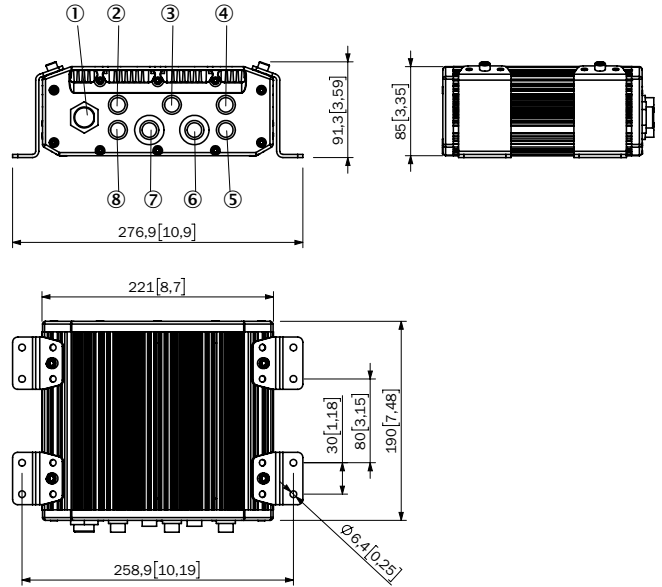

- ① M20, USB
- ② M14, 6-pin power supply EU,12/24 V
- ③ M14, 9-pin machine interface (Kit C)
- ④ M14, 2-pin external power supply (reserved, not implemented)
- ⑤ M14, 4-pin, additional alarm output
- ⑥ Bayonet, 10-pin sensor head, female
- ⑦ Bayonet, 10-pin sensor head, male
- ⑧ M14, 9-pin VGA/sound

Sensor head with protective cap (Visionary-B CV)

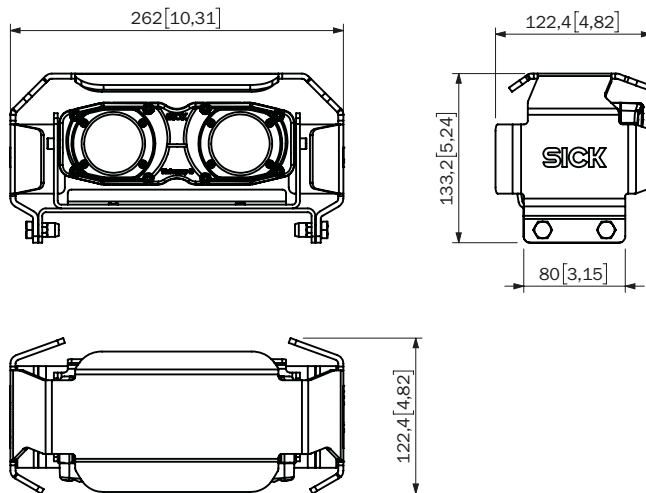

Monitor

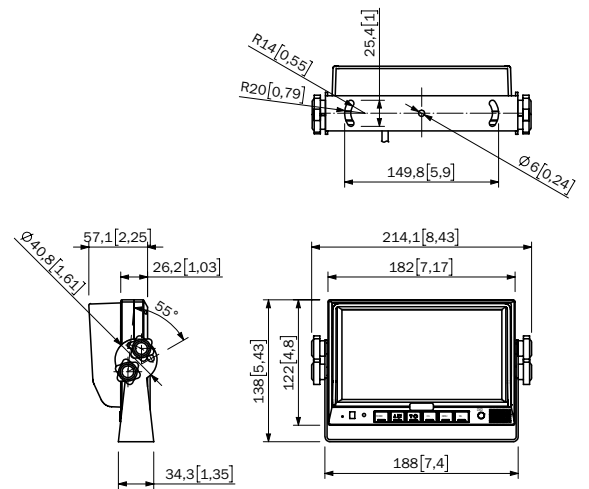

Mounting height and angle

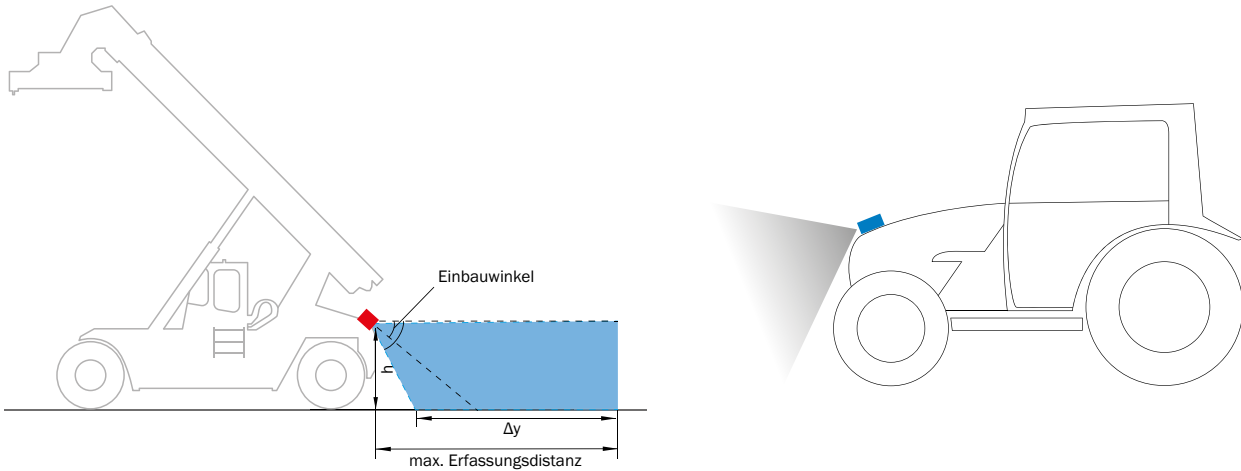

Mounting height (m)	1.0	1.2	1.4	1.6	1.8	2.0	2.2	2.4
Mounting angle (°)	0	- 6	- 11	- 17	- 23	- 29	- 31	- 33

Connection diagram

Visionary-B PS

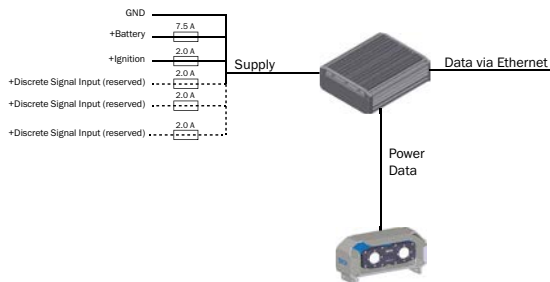

Cable sets are not included

Visionary-B CV, kit A

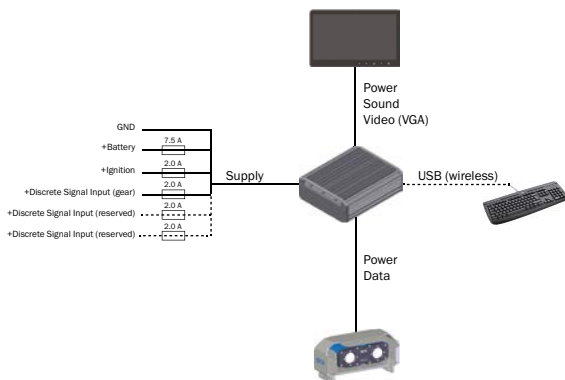

Keyboard and cable sets are not included in any of the kits

Visionary-B CV, kit B

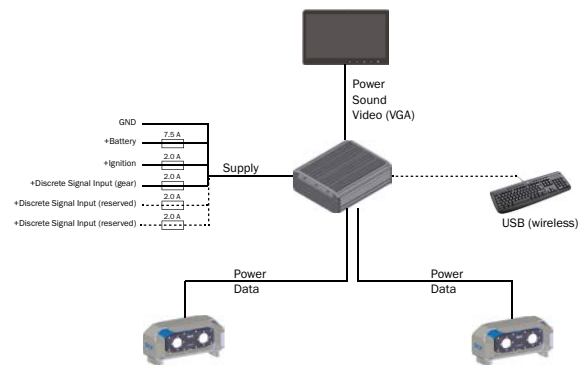

Two sensors operate by-turns.  
Keyboard and cable sets are not included in any kit.

Visionary-B CV, kit C

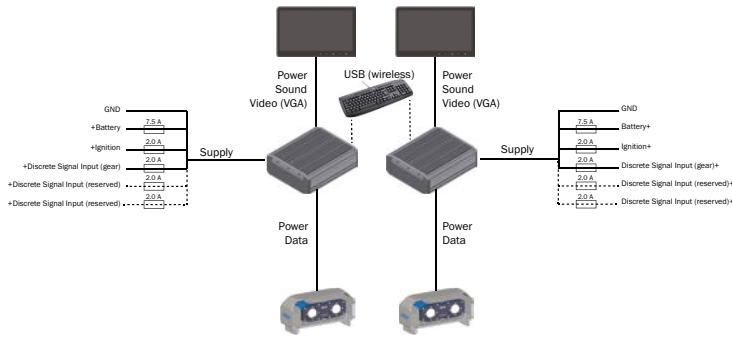



For extended field of view. Keyboard and cable sets are not included in any kit.

Accessories

Connection systems

Plug connectors and cables

	Cable	Length of cable	Type	Part no.
	Alarm cable for two discrete outputs, 0/12 V	5 m	Alarm cable	2086211
	Cable for connecting the sensor head and evaluation unit, You need two cables for kit B and kit C.	10 m	Connection cable, 10 pin (10 m)	2098102
		15 m	Connection cable, 10 pin (15 m)	2098103
		20 m	Connection cable, 10 pin (20 m)	2098104
		5 m	Connection cable, 10 pin (5 m)	2098101
		3 m	Connection cable, 10-pin (3 m)	2098100
	Ethernet cable for transmission of Visionary-B streaming data	5 m	Ethernet cable (5 m)	2098886

Reflectors and optics

Optics cloths

	Brief description	Type	Part no.
	Cloth for cleaning optical surfaces	Lens cloth	4003353







## REGISTER AT WWW.SICK.COM TO TAKE ADVANTAGE OF OUR FOLLOWING SERVICES FOR YOU





- ✔ Access information on net prices and individual discounts.
- ✔ Easily order online and track your delivery.
- ✔ Check your history of all your orders and quotes.
- ✔ Create, save, and share as many wish lists as you want.
- ✔ Use the direct order to quickly order a big amount of products.
- ✔ Check the status of your orders and quotes and get information on status changes by e-mail.
- ✔ Save time by using past orders.
- ✔ Easily export orders and quotes, suited to your systems.

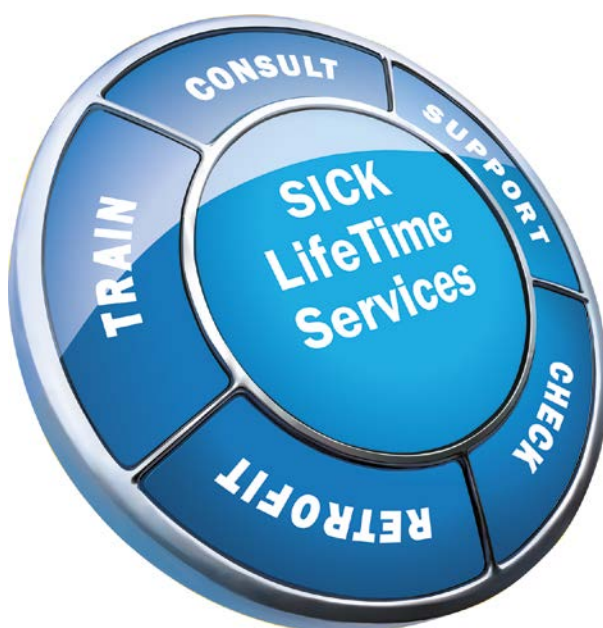

## SERVICES FOR MACHINES AND PLANTS: SICK LifeTime Services

Our comprehensive and versatile LifeTime Services are the perfect addition to the comprehensive range of products from SICK. The services range from product-independent consulting to traditional product services.



- 
**Consulting and design**  
 Safe and professional
- 
**Product and system support**  
 Reliable, fast, and on-site
- 
**Verification and optimization**  
 Safe and regularly inspected
- 
**Upgrade and retrofits**  
 Easy, safe, and economical
- 
**Training and education**  
 Practical, focused, and professional

## SICK AT A GLANCE

SICK is a leading manufacturer of intelligent sensors and sensor solutions for industrial applications. With more than 9,700 employees and over 50 subsidiaries and equity investments as well as numerous agencies worldwide, SICK is always close to its customers. A unique range of products and services creates the perfect basis for controlling processes securely and efficiently, protecting individuals from accidents, and preventing damage to the environment.

SICK has extensive experience in various industries and understands their processes and requirements. With intelligent sensors, SICK delivers exactly what the customers need. In application centers in Europe, Asia, and North America, system solutions are tested and optimized in accordance with customer specifications. All this makes SICK a reliable supplier and development partner.

Comprehensive services round out the offering: SICK LifeTime Services provide support throughout the machine life cycle and ensure safety and productivity.

**That is “Sensor Intelligence.”**

### **Worldwide presence:**

Australia, Austria, Belgium, Brazil, Canada, Chile, China, Czech Republic, Denmark, Finland, France, Germany, Great Britain, Hungary, Hong Kong, India, Israel, Italy, Japan, Malaysia, Mexico, Netherlands, New Zealand, Norway, Poland, Romania, Russia, Singapore, Slovakia, Slovenia, South Africa, South Korea, Spain, Sweden, Switzerland, Taiwan, Thailand, Turkey, United Arab Emirates, USA, Vietnam.

Detailed addresses and further locations → [www.sick.com](http://www.sick.com)