

Operating Instructions

Proline Promag 55

FOUNDATION Fieldbus

Electromagnetic Flow Measuring System

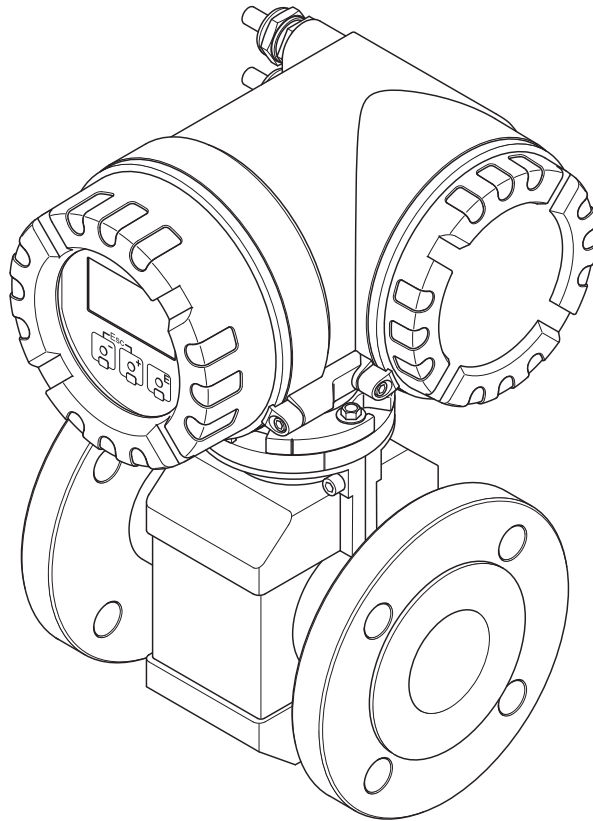

Table of contents

1	Safety instructions	4	8.3	Communication-specific accessories	78
1.1	Designated use	4	8.4	Service-specific accessories	78
1.2	Installation, commissioning and operation	4	9	Troubleshooting	79
1.3	Operational safety	4	9.1	Troubleshooting instructions	79
1.4	Return	5	9.2	System/process error messages	83
1.5	Notes on safety conventions and icons	5	9.3	Process errors without a message	89
2	Identification	6	9.4	Spare parts	90
2.1	Device designation	6	9.5	Return	96
2.2	Certificates and approvals	9	9.6	Disposal	96
2.3	FOUNDATION Fieldbus device certification	9	9.7	Software history	96
2.4	Registered trademarks	9	10	Technical data	97
3	Installation	10	10.1	Application	97
3.1	Incoming acceptance, transport and storage	10	10.2	Function and system design	97
3.2	Installation conditions	12	10.3	Input	97
3.3	Installation	20	10.4	Output	97
3.4	Post-installation check	34	10.5	Power supply	99
4	Wiring	35	10.6	Performance characteristics	100
4.1	FOUNDATION Fieldbus cable specification	35	10.7	Installation	101
4.2	Shielding and grounding	37	10.8	Environment	101
4.3	Connecting the remote version	38	10.9	Process	102
4.4	Connecting the measuring unit	43	10.10	Mechanical construction	106
4.5	Potential equalization	46	10.11	Operability	110
4.6	Degree of protection	48	10.12	Certificates and approvals	111
4.7	Post-connection check	49	10.13	Ordering information	112
5	Operation	50	10.14	Accessories	112
5.1	Quick operation guide	50	10.15	Documentation	112
5.2	Local display	51	Index	113	
5.3	Brief Operating Instructions for the function matrix	54			
5.4	Error messages	56			
5.5	Operating programs	57			
5.6	FOUNDATION Fieldbus hardware settings	59			
6	Commissioning	60			
6.1	Function check	60			
6.2	Switching on the measuring device	60			
6.3	Commissioning using FOUNDATION Fieldbus	61			
6.4	Adjustment	73			
6.5	Data storage devices	75			
7	Maintenance	76			
7.1	Exterior cleaning	76			
7.2	Seals	76			
8	Accessories	77			
8.1	Device-specific accessories	77			
8.2	Accessories specific to measuring principle	77			

1 Safety instructions

1.1 Designated use

The measuring device described in this Operating Manual is to be used only for measuring the flow rate of conductive fluids in closed pipes.

A minimum conductivity of 20 $\mu\text{S}/\text{cm}$ is required for measuring demineralized water. Most liquids can be measured as of a minimum conductivity of 5 $\mu\text{S}/\text{cm}$.

- Acids, alkalis, pastes, paps, pulps, black liquor, green liquor
- Drinking water, wastewater, sewage sludge,
- Milk, beer, wine, mineral water, yoghurt, molasses, fruit mash,
- Cement slurry, ore slurry (containing sand or stone), mud, silt

Incorrect use or use other than that designated may result in the operational safety of the measuring devices being suspended. The manufacturer accepts no liability for damages resulting from this.



1.2 Installation, commissioning and operation

Note the following points:

- Installation, connection to the electricity supply, commissioning and maintenance of the device must be carried out by trained, qualified specialists authorized to perform such work by the facility's owner-operator. The specialist must have read and understood these Operating Instructions and must follow the instructions they contain.
- The device must be operated only by persons authorized and trained by the system operator. Strict compliance with the instructions in the Operating Instructions is mandatory.
- Endress+Hauser is willing to assist in clarifying the chemical resistance properties of parts wetted by special fluids, including fluids used for cleaning. However, small changes in temperature, concentration or the degree of contamination in the process can result in changes to the chemical resistance properties. For this reason, Endress+Hauser does not accept any responsibility with regard to the corrosion resistance of materials wetted by fluids in a specific application. The user is responsible for the choice of wetted materials with regard to their in-process resistance to corrosion.
- If welding work is performed on the piping system, do not ground the welding appliance through the flowmeter.
- The installer must ensure that the measuring system is correctly wired in accordance with the wiring diagrams. The transmitter must be grounded, except in cases where special protective measures have been taken (e.g. galvanically isolated power supply SELV or PELV).
- Always note the regulations applicable in your country to the operation, maintenance and repair of electrical devices. Special instructions relating to the device can be found in the relevant sections of the documentation.
- The Promag 55 flow measuring device can also measure extremely abrasive fluids, e.g. ore slurry, cement etc. To protect the measuring tube lining from excessive abrasion, the use of additional liner protection plates is recommended in such cases.

1.3 Operational safety

Note the following points:

- Measuring systems for use in hazardous environments are accompanied by separate "Ex documentation", which is an integral part of these Operating Instructions. Strict compliance with the installation instructions and ratings as stated in this supplementary documentation is mandatory. Depending on the approval and certification agency, the relevant symbol is depicted on the front page of the supplementary documentation on Ex ratings (e.g.  Europe,  USA,  Canada).

- The measuring device meets the general safety requirements according to EN 61010-1 and the EMC requirements according to IEC/EN 61326 in addition to the NAMUR recommendations NE 21, NE 43 and NE 53.
- Depending on the application, the seals of the process connections of the Promag H sensor require periodic replacement.
- Due to the performance rate in the electronic components, the external housing surfaces are heated to a maximum of 10 K. When conducting hot media through the measuring tube, the surface temperature of the housing increases. Particularly in the case of the sensor, temperatures close to the fluid temperature must be anticipated. In the event of elevated fluid temperatures, please ensure that fire protection is in place.
- The manufacturer reserves the right to modify technical data without prior notice. Your Endress+Hauser distributor will supply you with current information and updates to these Operating Instructions.

1.4 Return

The measuring device must be returned if repairs or a factory calibration are required, or if the wrong measuring device has been ordered or delivered. According to legal regulations, Endress+Hauser, as an ISO-certified company, is required to follow certain procedures when handling returned products that are in contact with medium.

To ensure swift, safe and professional device returns, please read the return procedures and conditions on the Endress+Hauser website at www.services.endress.com/return-material

1.5 Notes on safety conventions and icons

The devices are designed and tested to meet state-of-the-art safety requirements, and have left the factory in a condition in which they are safe to operate. The devices comply with the applicable standards and regulations in accordance with EN 61010 -1 "Protection Measures for Electrical Equipment for Measurement, Control, Regulation and Laboratory Procedures". The devices can, however, be a source of danger if used incorrectly or for other than the designated use.

For this reason, always pay particular attention to the safety instructions indicated in these Operating Instructions by the following icons:



Warning!

"Warning" indicates an action or procedure which, if not performed correctly, can result in personal injury or a safety hazard. Comply strictly with the instructions and proceed with care.



Caution!

"Caution" indicates an action or procedure which, if not performed correctly, can result in incorrect operation or destruction of the device. Comply strictly with the instructions.



Note!

"Note" indicates an action or procedure which, if not performed correctly, can have an indirect effect on operation or trigger an unexpected response on the part of the device.

2 Identification

2.1 Device designation

The flow measuring system consists of the following components:

- Promag 55 transmitter
- Promag S and Promag H sensors

Two versions are available:

- Compact version: transmitter and sensor form a single mechanical unit.
- Remote version: transmitter and sensor are installed separately.

2.1.1 Nameplate of the transmitter

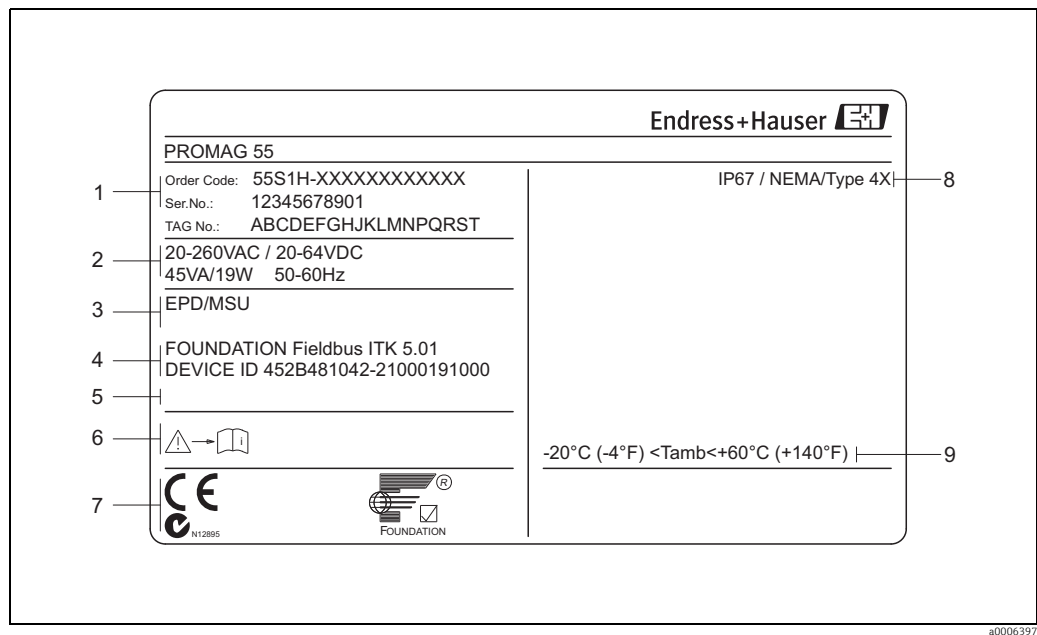

Fig. 1: Nameplate specifications for the "Promag 55" transmitter (example)

- 1 Order code/serial number: See the specifications on the order confirmation for the meanings of the individual letters and digits
- 2 Power supply/frequency/power consumption
- 3 Additional functions and software
 - EPD: with empty pipe detection electrode
- 4 FOUNDATION Fieldbus: equipped with FOUNDATION Fieldbus H1 interface
ITK 5.01: certified by the Fieldbus Foundation; Interoperability Test Kit, revision 5.01
DEVICE ID: FOUNDATION Fieldbus device identification
- 5 Reserved for additional information on special products
- 6 Observe device documentation
- 7 Reserved for certificates, approvals and additional information on device version
- 8 Degree of protection
- 9 Permitted ambient temperature range

2.1.2 Nameplate of the sensor

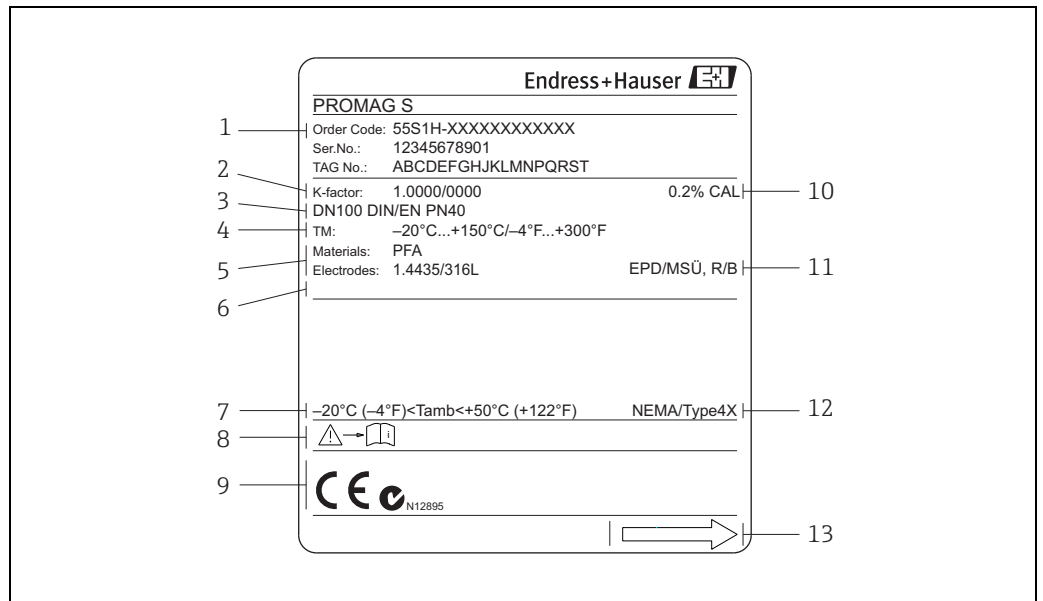

Fig. 2: Nameplate specifications for the 'Promag S' sensor (example)

- 1 Order code/serial number: See the specifications on the order confirmation for the meanings of the individual letters and digits
- 2 Calibration factor with zero point
- 3 Nominal diameter/nominal pressure
- 4 Medium temperature range
- 5 Materials:
lining/measuring electrode
- 6 Reserved for additional information on special products
- 7 Permitted ambient temperature range
- 8 Please comply with the Operating Instructions
- 9 Reserved for additional information on device version (approvals, certificates)
- 10 Calibration tolerance
- 11 Additional information
 - EPD:
with empty pipe detection electrode
 - R/B:
with reference electrode
- 12 Degree of protection
- 13 Flow direction

2.1.3 Nameplate for connections

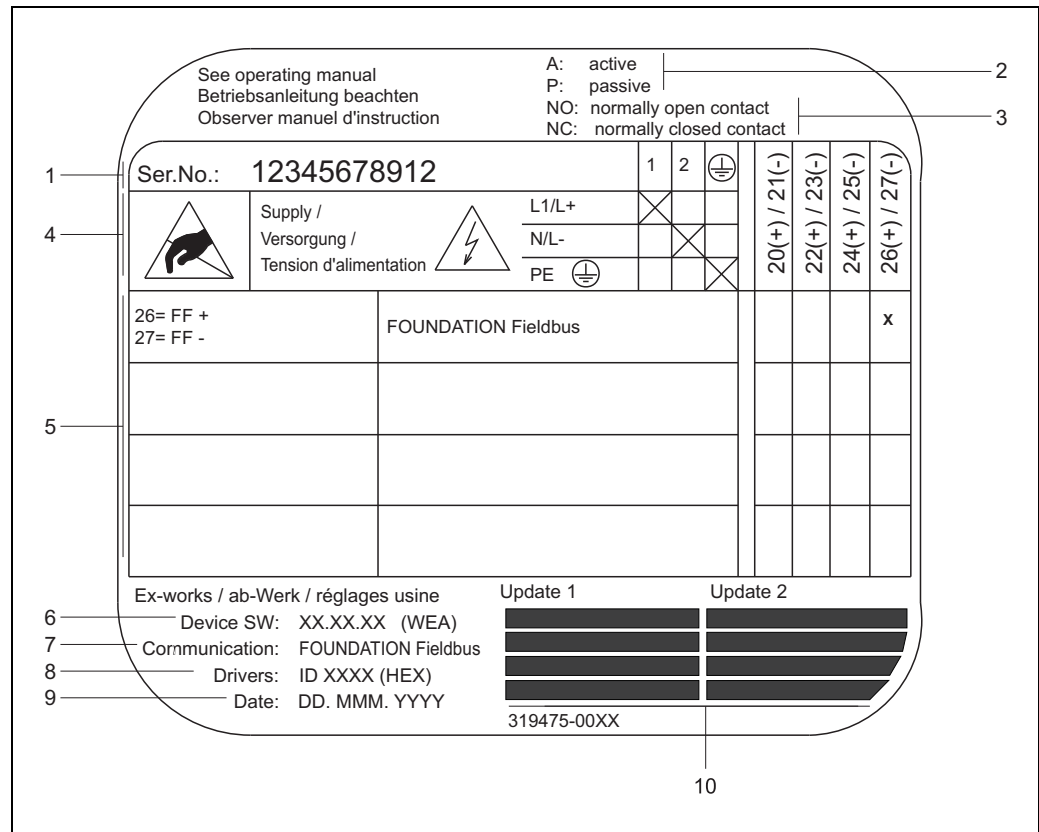

Fig. 3: Nameplate specifications for Proline transmitter connections (example)

- 1 Serial number
- 2 Possible configuration of current output
- 3 Possible configuration of relay contacts
- 4 Terminal assignment, cable for power supply
Terminal no. 1:
- L1 for AC, L+ for DC
Terminal no. 2:
- N for AC, L- for DC
- 5 Signals present at inputs and outputs, possible configurations and terminal assignment
- 6 Version of device software currently installed (incl. language group)
- 7 Type of communication installed
- 8 Information on current communication software (Device Revision, Device Description)
- 9 Date of installation
- 10 Current updates to data specified in points 6 to 9

2.2 Certificates and approvals

The devices are designed and tested to meet state-of-the-art safety requirements in accordance with sound engineering practice. They have left the factory in a condition in which they are safe to operate. The devices comply with the standards EN 61010 -1 "Protection Measures for Electrical Equipment for Measurement, Control, Regulation and Laboratory Procedures" and with the EMC requirements of IEC/EN 61326. The measuring system described in these Operating Instructions therefore complies with the legal requirements of the EU Directives. Endress+Hauser confirms this by affixing the CE mark to it and by issuing the CE Declaration of Conformity. The measuring system is in conformity with the EMC requirements of the "Australian Communications and Media Authority (ACMA)".

2.3 FOUNDATION Fieldbus device certification

The flowmeter has passed all the test procedures implemented and has been certified and registered by the Fieldbus Foundation. The device thus meets all the requirements of the following specifications:

- Certified to FOUNDATION Fieldbus specification
- The flowmeter meets all the specifications of the FOUNDATION Fieldbus H1.
- Interoperability Test Kit (ITK), revision 5.01: The device can also be operated in conjunction with other manufactures certified devices.
- Physical Layer Conformance Test by Fieldbus Foundation

2.4 Registered trademarks

KALREZ[®] and VITON[®]

Registered trademarks of E.I. Du Pont de Nemours & Co., Wilmington, USA

TRI-CLAMP[®]

Registered trademark of Ladish & Co., Inc., Kenosha, USA

FOUNDATION[™] Fieldbus

Registered trademark of the Fieldbus Foundation, Austin, USA

HistoROM[™], S-DAT[®], T-DAT[™], F-CHIP[®], FieldCare[®], Fieldcheck[®], Applicator[®]

Registered or registration-pending trademarks of the Endress+Hauser Flowtec Group

3 Installation

3.1 Incoming acceptance, transport and storage

3.1.1 Incoming acceptance

On receipt of the goods, check the following points:

- Check the packaging and the contents for damage.
- Check the shipment, make sure nothing is missing and that the scope of supply matches your order.

3.1.2 Transport

The following instructions apply to unpacking and to transporting the device to its final location:

- Transport the devices in the containers in which they are delivered.
- Do not remove the protection plates or caps on the process connections until you are ready to install the device. This is particularly important in the case of sensors with PTFE linings.

Special notes on flanged devices



Caution!

- The wooden covers mounted on the flanges before the device leaves the factory protect the linings on the flanges during storage and transportation. Do not remove these protection plates until *immediately before* the device is installed in the pipe.
- Do not lift flanged devices by the transmitter housing or, in the case of the remote version, by the connection housing.

Transporting flanged devices (DN ≤ 300) 12"

Use webbing slings slung round the two process connections. Do not use chains, as they could damage the housing.



Warning!

Risk of injury if the measuring device slips. The center of gravity of the assembled measuring device might be higher than the points around which the slings are slung. At all times, therefore, make sure that the device does not unexpectedly turn around its axis or slip.

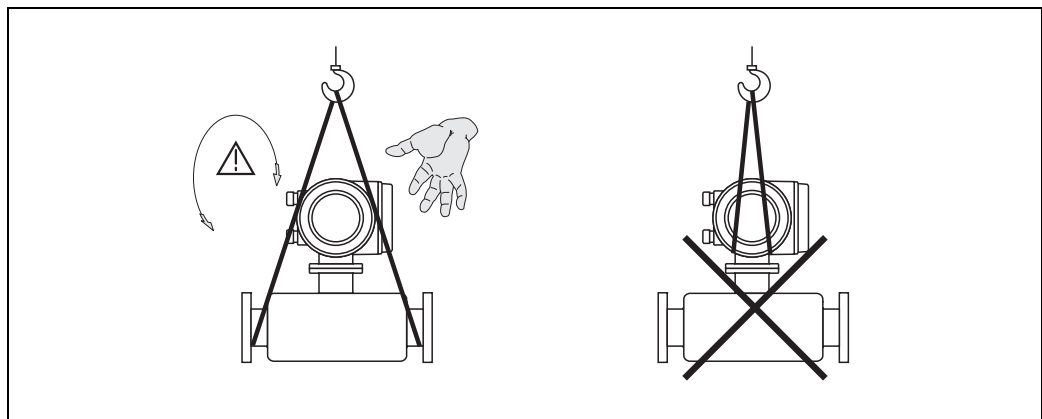

Fig. 4: Transporting sensors with DN ≤ 300 (12")

a0004294

Transporting flanged devices DN > 300 (12")

Use only the metal eyes on the flanges for transporting the device, lifting it and positioning the sensor in the piping.



Caution!

Do not attempt to lift the sensor with the tines of a fork-lift truck beneath the metal casing. This would buckle the casing and damage the internal magnetic coils.

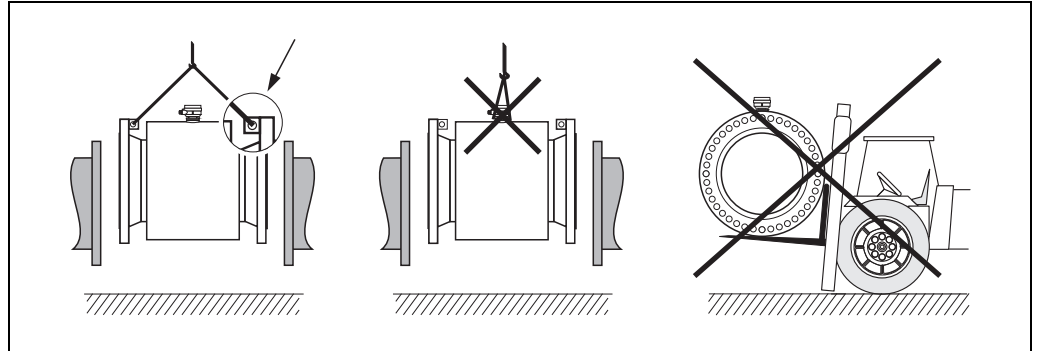

Fig. 5: Transporting sensors with DN > 300 (12")

3.1.3 Storage

Note the following points:

- Pack the measuring device in such a way as to protect it reliably against impact for storage (and transportation). The original packaging provides optimum protection.
- The storage temperature corresponds to the operating temperature range of the measuring transmitter and the appropriate measuring sensors → 101.
- The measuring device must be protected against direct sunlight during storage in order to avoid unacceptably high surface temperatures.
- Choose a storage location where moisture does not collect in the measuring device. This will help prevent fungus and bacteria infestation which can damage the lining.
- Do not remove the protection plates or caps on the process connections until you are ready to install the device. This is particularly important in the case of sensors with PTFE linings.

3.2 Installation conditions

3.2.1 Dimensions

The dimensions and installation lengths of the sensor and transmitter can be found in the "Technical Information" for the device in question. This document can be downloaded as a PDF file from www.endress.com. A list of the "Technical Information" documents available is provided in the "Documentation" section on → [112](#).

3.2.2 Mounting location

The accumulation of air or gas bubbles in the measuring tube could result in an increase in measuring errors.

Avoid the following locations:

- At the highest point of a pipeline. Risk of air accumulating.
- Directly upstream from a free pipe outlet in a vertical pipeline.

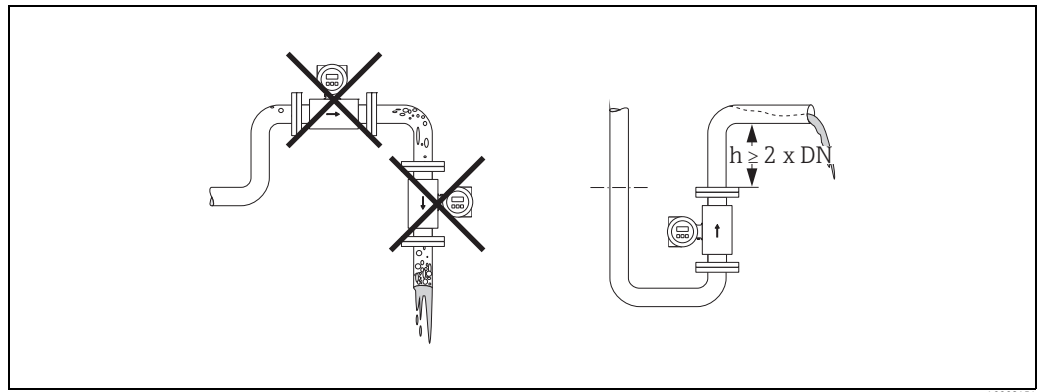

Fig. 6: Mounting location

Installing pumps

Do not install the sensor on the intake side of a pump. This precaution is to avoid low pressure and the consequent risk of damage to the lining of the measuring tube. Information on the lining's resistance to partial vacuum → [104](#).

It might be necessary to install pulse dampers in systems incorporating reciprocating, diaphragm or peristaltic pumps. Information on the measuring system's resistance to vibration and shock → [102](#).

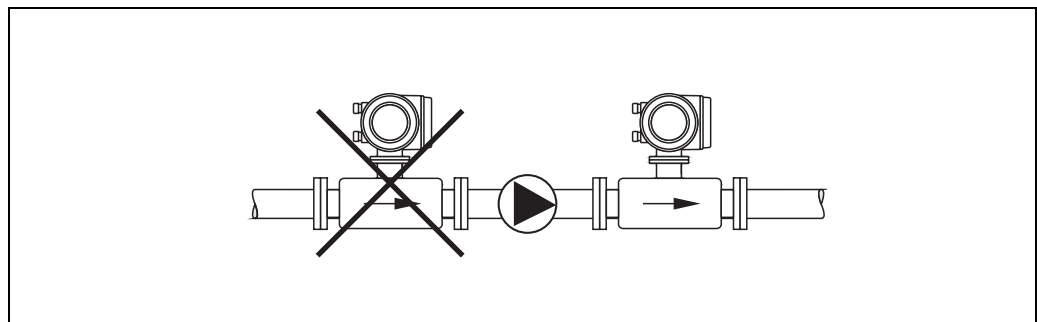

Fig. 7: Installing pumps

Partially filled pipes

Partially filled pipes with gradients necessitate a drain-type configuration. The Empty Pipe Detection function offers additional protection by detecting empty or partially filled pipes → [73](#).

**Caution!**

Risk of solids accumulating. Do not install the sensor at the lowest point in the drain. It is advisable to install a cleaning valve.

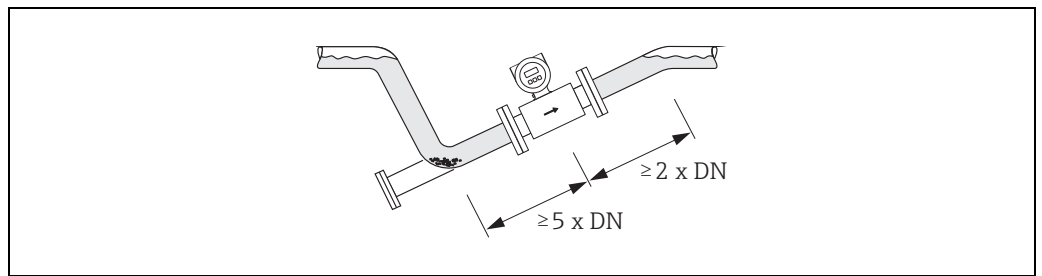

Fig. 8: Installation in partially filled pipe

A0008155

Down pipes

Install a siphon or a vent valve downstream of the sensor in down pipes longer than 5 m (16.3 ft). This precaution is to avoid low pressure and the consequent risk of damage to the lining of the measuring tube. This measure also prevents the system losing prime, which could cause air inclusions. Information on the lining's resistance to partial vacuum → 104.

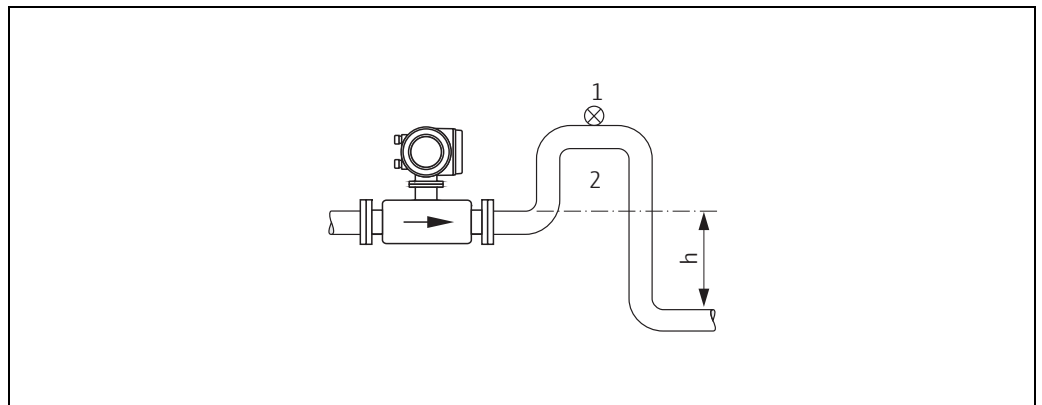

Fig. 9: Measures for installation in a down pipe ($h > 5 \text{ m}/16 \text{ ft}$)

- 1 Vent valve
- 2 Siphon
- h Length of down pipe ($h \geq 5 \text{ m}$ (16.3 ft))

A0011902

3.2.3 Orientation

An optimum orientation position helps avoid gas and air accumulations and deposits in the measuring tube. Promag, nevertheless, supplies a range of functions and accessories for correct measuring of problematic fluids:

- Electrode Cleaning Circuitry (ECC) to prevent electrically conductive deposits in the measuring tube, e.g. for fluids causing buildup (see "Description of Device Functions" manual).
- Empty Pipe Detection (EPD) ensures the detection of partially filled measuring tubes or in the case of degassing fluids → 73.

Vertical orientation

A vertical orientation is ideal in the following cases:

- For self-emptying piping systems and when using empty pipe detection.
- For sludge containing sand or stones and where the solids cause sedimentation.

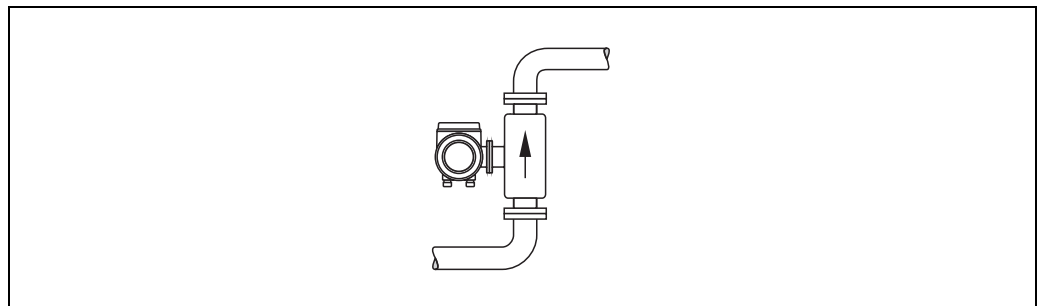

A0011903

Fig. 10: Vertical orientation

Horizontal orientation

The measuring electrode plane should be horizontal. This prevents brief insulation of the two electrodes by entrained air bubbles.



Caution!

Empty Pipe Detection functions correctly with the measuring device installed horizontally only when the transmitter housing is facing upward (see diagram). Otherwise there is no guarantee that Empty Pipe Detection will respond if the measuring tube is only partially filled.

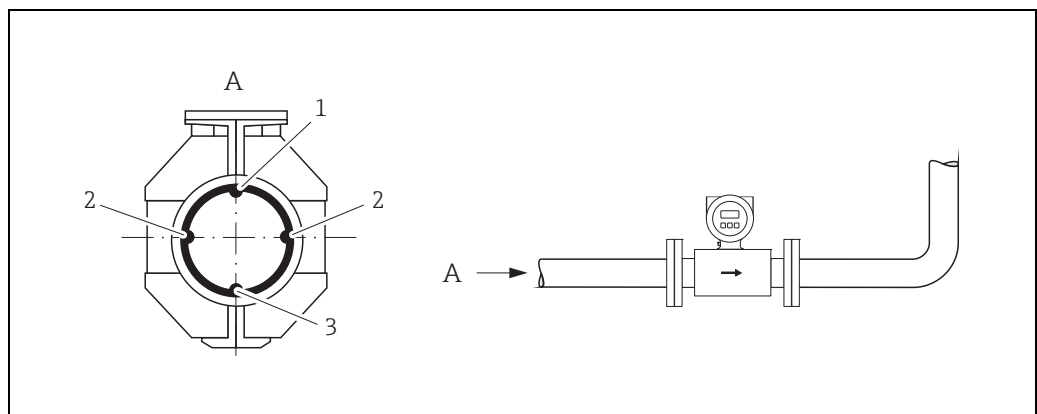

A0003207

Fig. 11: Horizontal orientation

- 1 EPD electrode for empty pipe detection
(not available for "measuring electrode only" option, not in Promag H, DN 2 to 8/ 1/2 to 5/16)
- 2 Measuring electrodes for signal detection
- 3 Reference electrode for potential equalization
(not available for "measuring electrode only" option, not in Promag H)

3.2.4 Inlet and outlet runs

If possible, install the sensor in a location upstream of fittings such as valves, T-pieces, elbows, etc.

Compliance with the following requirements for the inlet and outlet runs is necessary in order to ensure measuring accuracy.

- Inlet run $\geq 5 \times \text{DN}$
- Outlet run $\geq 2 \times \text{DN}$

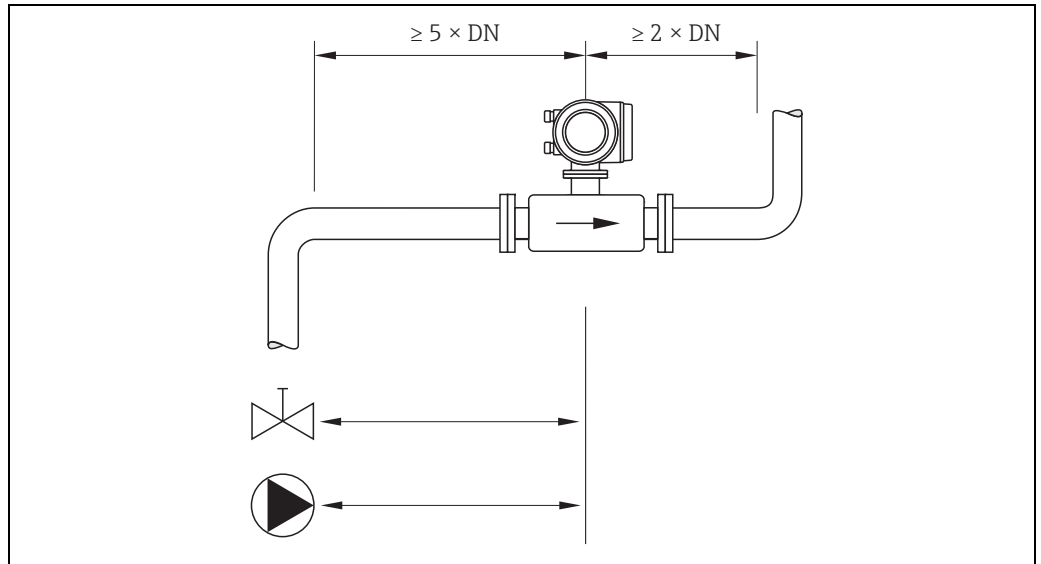

Fig. 12: Inlet and outlet runs

3.2.5 Vibrations

Secure and fix both the piping and the sensor if the vibrations are severe.



Caution!

It is advisable to install sensor and transmitter separately if vibration is excessively severe. Information on the permitted resistance to vibration and shock → 102.

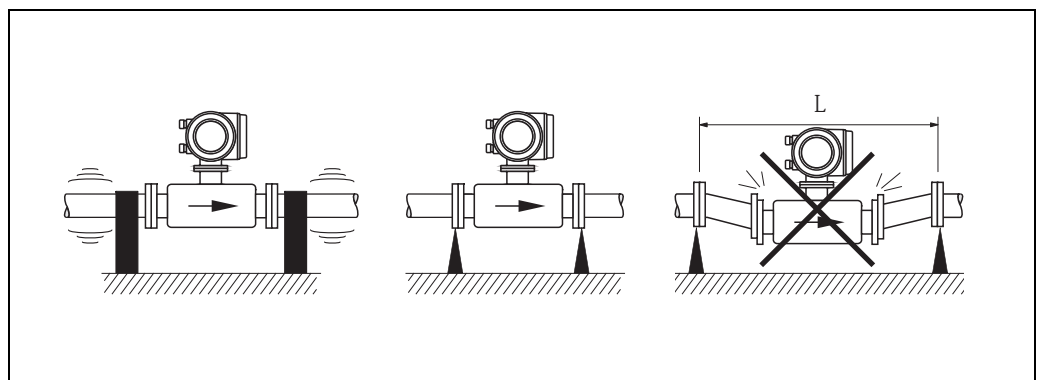

Fig. 13: Measures to prevent vibration of the measuring device ($L > 10 \text{ m/33 ft}$)

3.2.6 Foundations, supports

If the nominal diameter is $DN \geq 350$ (14"), mount the sensor on a foundation of adequate load-bearing strength.



Caution!

Risk of damage.

Do not support the weight of the sensor on the metal casing: the casing would buckle and damage the internal magnetic coils.

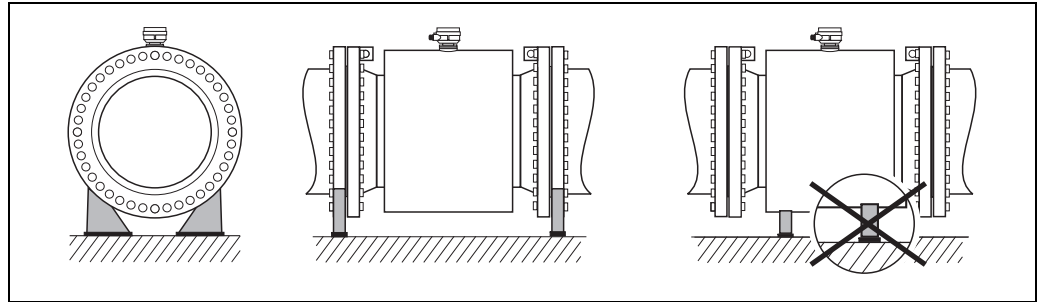

Fig. 14: Correct support for large nominal diameters ($DN \geq 350/14''$)

3.2.7 Adapters

Suitable adapters to DIN EN 545 (double-flange reducers) can be used to install the sensor in larger-diameter pipes. The resultant increase in the rate of flow improves measuring accuracy with very slow-moving fluids.

The nomogram shown here can be used to calculate the pressure loss caused by cross-section reduction.



Note!

- The nomogram only applies to liquids of viscosity similar to water.
- For Promag H the selection of a pipe with larger diameter for high viscosities of the fluid may be considered to reduce the pressure loss.

1. Calculate the ratio of the diameters d/D .
2. From the nomogram, read off the pressure loss as a function of fluid velocity (*downstream* from the reduction) and the d/D ratio.

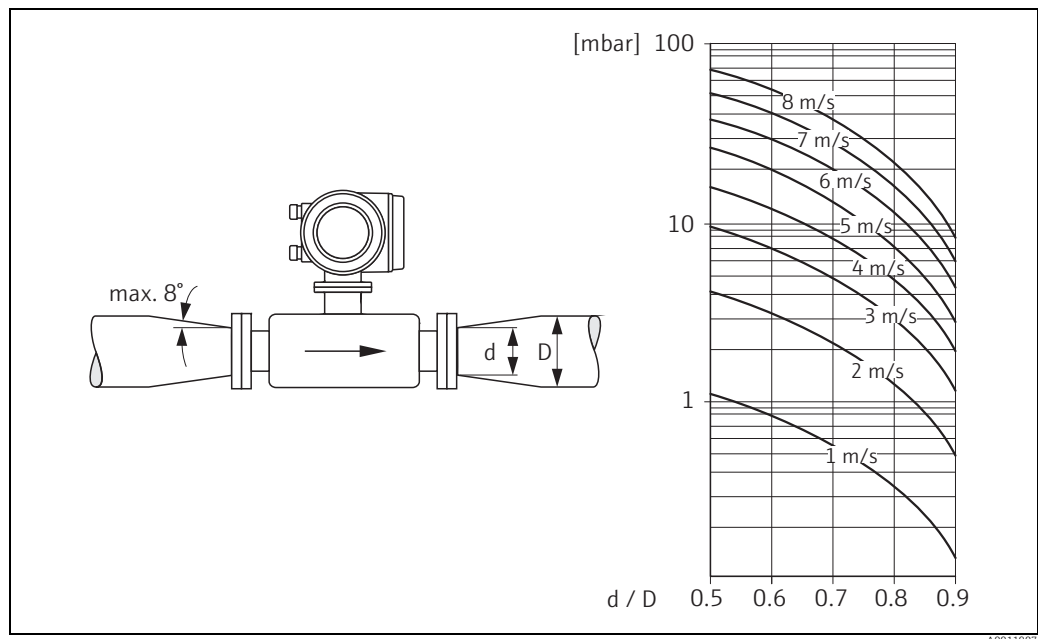

Fig. 15: Pressure loss due to adapters

3.2.8 Nominal diameter and flow rate

The diameter of the pipe and the flow rate determine the nominal diameter of the sensor. The optimum flow velocity is between 2 and 3 m/s (6.5 to 9.8 ft/s). The flow velocity (v), moreover, has to be matched to the physical properties of the fluid:

- $v < 2$ m/s (< 6 ft/s): for abrasive fluids where solids do not cause sedimentation (e.g. lime milk)
- $v > 2$ m/s (> 6 ft/s): for fluids producing buildup (e.g. wastewater sludge)
- $v > 2$ m/s (> 6 ft/s): for abrasive sludge with a high sand or stone content and where the solids easily cause sedimentation (e.g. ore slurry)



Note!

- A necessary increase in the flow velocity can be achieved by reducing the sensor nominal diameter through the use of adapters → 16.
- For Promag H the selection of a pipe with nominal diameter $> \text{DN } 8$ ($\frac{3}{8}$ ") for fluids with high levels of solids may be considered, to improve the stability of the signal and cleanability due to larger electrodes.

Recommended flow (SI units)



Nominal diameter [mm]	Promag S	Promag H	Factory settings Promag S	Factory settings Promag H		
	min./max. full scale value ($v \approx 0.3$ or 10 m/s) [dm ³ /min]		Low flow cut off ($v \approx 0.04$ m/s) in [dm ³ /min]	Full scale value ($v \approx 2.5$ m/s) [dm ³ /min]	Pulse value(≈ 2 Pulse/s) [dm ³]	Low flow cut off ($v \approx 0.04$ m/s) [dm ³ / min]
2	-	0.06 to 1.8	-	0.5	0.005	0.01
4	-	0.25 to 7	-	2	0.025	0.05
8	-	1 to 30	-	8	0.10	0.1
15	4 to 100	4 to 100	0.5	25	0.20	0.5
25	9 to 300	9 to 300	1	75	0.50	1
32	15 to 500	15 to 500	2	125	1.00	2
40	25 to 700	25 to 700	3	200	1.50	3
50	35 to 1100	35 to 1100	5	300	2.50	5
65	60 to 2000	60 to 2000	8	500	5.00	8
80	90 to 3000	90 to 3000	12	750	5.00	12
100	145 to 4700	145 to 4700	20	1200	10.00	20
125	220 to 7500	220 to 7500	30	1850	15	30
[mm]	min./max. full scale value ($v \approx 0.3$ or 10 m/s) in [m ³ /h]					
150	20 to 600	20 to 600	2.5	150	0.03	2.5
200	35 to 1100	-	5.0	-	-	-
250	55 to 1700	-	7.5	-	-	-
300	80 to 2400	-	10	-	-	-
350	110 to 3300	-	15	-	-	-
400	140 to 4200	-	20	-	-	-
450	180 to 5400	-	25	-	-	-
500	220 to 6600	-	30	-	-	-
600	310 to 9600	-	40	-	-	-

Recommended flow (US units)

Nominal diameter [inch]	Promag S	Promag H	Factory settings Promag S	Factory settings Promag H		
	min./max. full scale value ($v \approx 1.0$ or 33 ft/s) in [gal/min]		Low flow cut off ($v \approx 1.0$ ft/s) in [gal/min]	full scale value ($v \approx 2.5$ m/s) [gal/min]	Pulse value (≈ 2 Pulse/s) [gal]	Low flow cut off ($v \approx 0.04$ m/s) [gal/ min]
1/12"	–	0.015 to 0.5	–	0.1	0.001	0.002
1/8"	–	0.07 to 2	–	0.5	0.005	0.008
3/8"	–	0.25 to 8	–	2	0.02	0.025
1/2"	1.0 to 27	1.0 to 27	0.10	6	0.05	0.10
1"	2.5 to 80	2.5 to 80	0.25	18	0.20	0.25
1 1/2"	7 to 190	7 to 190	0.75	50	0.50	0.75
2"	10 to 300	10 to 300	1.25	75	0.50	1.25
3"	24 to 800	24 to 800	2.5	200	2	2.5
4"	40 to 1250	40 to 1250	4.0	300	2	4.0
6"	90 to 2650	90 to 2650	12	–	–	–
8"	155 to 4850	–	15	–	–	–
10"	250 to 7500	–	30	–	–	–
12"	350 to 10600	–	45	–	–	–
14"	500 to 15000	–	60	–	–	–
16"	600 to 19000	–	60	–	–	–
18"	800 to 24000	–	90	–	–	–
20"	1000 to 30000	–	120	–	–	–
24"	1400 to 44000	–	180	–	–	–

3.2.9 Length of connecting cable

In order to ensure measuring accuracy, please comply with the following instructions when installing the remote version:

- Secure the cable run or route the cable in an armored conduit. Movement of the cable can falsify the measuring signal, particularly if the fluid conductivity is low.
- Route the cable well clear of electrical machines and switching elements.
- Ensure potential equalization between sensor and transmitter, if necessary.
- The permissible cable length L_{\max} depends on the fluid conductivity (\rightarrow  16, \rightarrow  17).
- The maximum connecting cable length is 10 m (32.8 ft) when empty pipe detection (EPD \rightarrow  73) is switched on.

Promag S

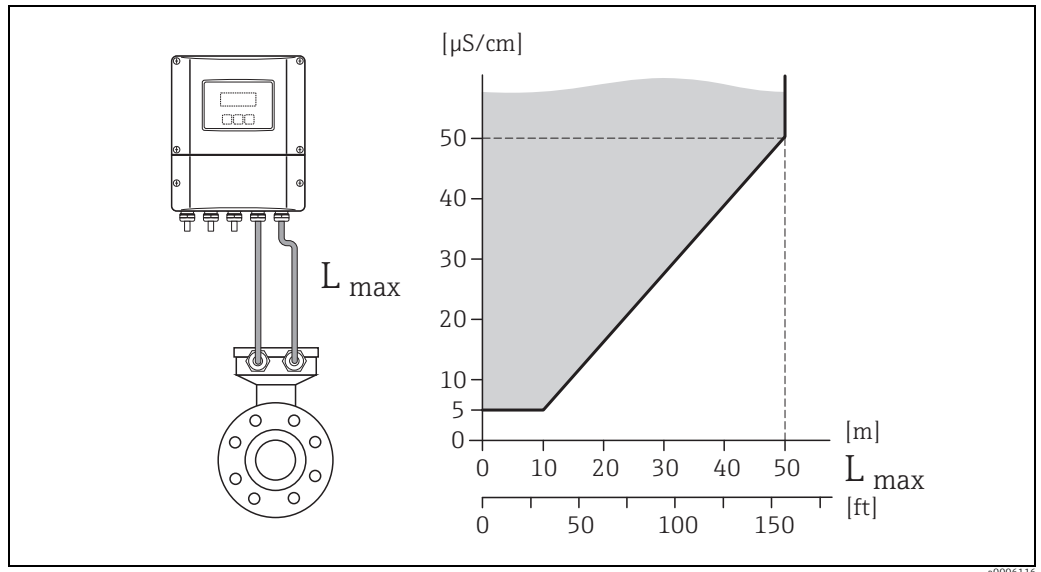

Fig. 16: Permitted lengths for connecting cable in remote version, as a function of the conductivity of the fluid
 Gray shaded area = permissible range
 L_{max} = length of connecting cable

Promag H

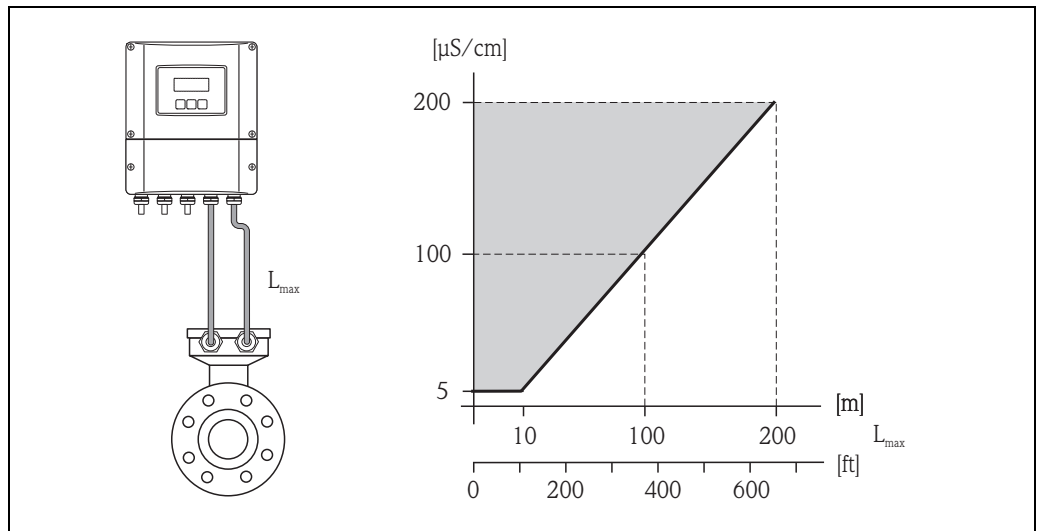

Fig. 17: Permitted lengths for connecting cable in remote version, as a function of the conductivity of the fluid
 Gray shaded area = permissible range
 L_{max} = length of connecting cable

3.3 Installation

3.3.1 Installing the Promag S sensor



Note!

Bolts, nuts, seals, etc. are not included in the scope of supply and must be supplied by the customer.



Caution!

- The protective covers mounted on the two sensor flanges guard the PTFE lining, which is turned over the flanges. Consequently, do not remove these protection plates **until immediately before** the sensor is installed in the pipe.
- Protection plates must remain in place while the device is in storage.
- Make sure that the lining is not damaged or removed from the flanges.

The sensor is designed for installation between the two piping flanges:

- It is essential that you observe the necessary torques on → 21.
- If grounding disks are used, follow the mounting instructions which will be enclosed with the shipment.

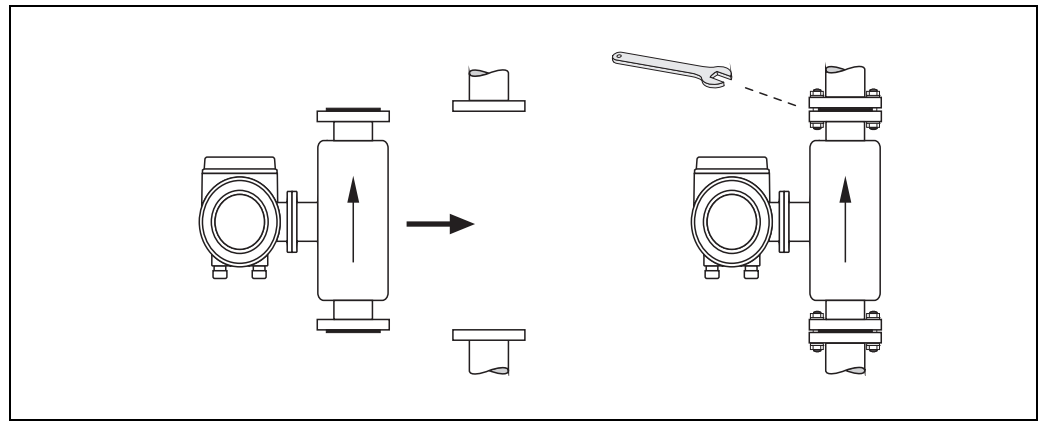

Fig. 18: Sensor installation

Seals

Comply with the following instructions when installing seals:

- Hard rubber lining → Additional seals are **always** required.
- Natural rubber lining → Seals may **not** be used.
- PFA, PTFE or PU (polyurethane) lining → **No** seals are required.
- Make sure that the seals do not protrude into the piping cross-section.



Caution!

Risk of short circuit! Do not use electrically conductive sealing compound such as graphite. An electrically conductive layer could form on the inside of the measuring tube and short-circuit the measuring signal.

Ground cable (DN 15 to 600 / ½ to 24")

Ground cables are optionally available in different versions from Endress+Hauser:

- Ground cable preinstalled at the flange → Order option (see price list)
- Ground cable (not pre-installed) as an accessory → 77

Detailed assembly instructions → 46

Screw tightening torques

Note the following points:

- The screw tightening torques listed below apply only to lubricated threads and to pipes not subjected to tensile stress.
- Always tighten the screws uniformly and in diagonally opposite sequence.
- Overtightening the screws will deform the sealing faces or damage the seals.

Tightening torques for:

- EN (DIN) → 21
- ASME B16.5 → 22
- JIS → 23
- AS 2129 → 24
- AS 4087 → 25

Promag S screw tightening torques for EN 1092-1 (DIN 2501), PN 10/16/25/40

Promag S Nominal diameter [mm]	EN (DIN) Pressure rating	Threaded fasteners	Flange thickness [mm]	Max. tightening torque [Nm]				
				Natural rubber	Polyurethane	PTFE	PFA	Hard rubber
15	PN 40	4 × M 12	16	–	–	11	–	–
25	PN 40	4 × M 12	18	–	15	26	20	–
32	PN 40	4 × M 16	18	–	24	41	35	–
40	PN 40	4 × M 16	18	–	31	52	47	–
50	PN 40	4 × M 16	20	–	40	65	59	–
65 *	PN 16	8 × M 16	18	11	27	43	40	32
65	PN 40	8 × M 16	22	–	27	43	40	32
80	PN 16	8 × M 16	20	13	34	53	48	40
80	PN 40	8 × M 16	24	–	34	53	48	40
100	PN 16	8 × M 16	20	14	36	57	51	43
100	PN 40	8 × M 20	24	–	50	78	70	59
125	PN 16	8 × M 16	22	19	48	75	67	56
125	PN 40	8 × M 24	26	–	71	111	99	83
150	PN 16	8 × M 20	22	27	63	99	85	74
150	PN 40	8 × M 24	28	–	88	136	120	104
200	PN 10	8 × M 20	24	35	91	141	101	106
200	PN 16	12 × M 20	24	28	61	94	67	70
200	PN 25	12 × M 24	30	–	92	138	105	104
250	PN 10	12 × M 20	26	27	71	110	–	82
250	PN 16	12 × M 24	26	48	85	131	–	98
250	PN 25	12 × M 27	32	–	134	200	–	150
300	PN 10	12 × M 20	26	34	81	125	–	94
300	PN 16	12 × M 24	28	67	118	179	–	134
300	PN 25	16 × M 27	34	–	138	204	–	153
350	PN 10	16 × M 20	26	47	118	188	–	112
350	PN 16	16 × M 24	30	68	165	254	–	152
350	PN 25	16 × M 30	–	–	252	380	–	227
400	PN 10	16 × M 24	26	65	167	260	–	151

Promag S Nominal diameter [mm]	EN (DIN) Pressure rating	Threaded fasteners	Flange thickness [mm]	Max. tightening torque [Nm]				
				Natural rubber	Polyureth ane	PTFE	PFA	Hard rubber
400	PN 16	16 × M 27	32	95	215	330	-	193
400	PN 25	16 × M 33	-	-	326	488	-	289
450	PN 10	20 × M 24	28	59	133	235	-	153
450	PN 16	20 × M 27	40	96	196	300	-	198
450	PN 25	20 × M 33	-	-	253	385	-	256
500	PN 10	20 × M 24	28	66	171	265	-	155
500	PN 16	20 × M 30	34	132	300	448	-	275
500	PN 25	20 × M 33	-	-	360	533	-	317
600	PN 10	20 × M 27	28	93	219	345	-	206
600 *	PN 16	20 × M 33	36	202	443	658	-	415
600	PN 25	20 × M 36	-	-	516	731	-	431

* Designed acc. to EN 1092-1 (not to DIN 2501)

Promag S screw tightening torques for EN 1092-1, PN 10/16/25, stainless-steel; Calculated according to EN 1591-1:2014 for flange according to EN 1092-1:2013

Nominal diameter [mm]	EN (DIN) Pressure rating	Threaded fasteners	Flange thickness	Nom. tightening torque				
				Natural rubber [Nm]	Polyurethane [Nm]	PTFE [Nm]	PFA [Nm]	Hard rubber [Nm]
350	PN 10	16 × M 20	26	80	80	60	-	70
350	PN 16	16 × M 24	30	135	135	115	-	125
350	PN 25	16 × M 30	-	-	235	220	-	230
400	PN 10	16 × M 24	26	110	120	90	-	100
400	PN 16	16 × M 27	32	180	190	155	-	175
400	PN 25	16 × M 33	-	-	325	290	-	315
450	PN 10	20 × M 24	28	105	110	90	-	100
450	PN 16	20 × M 27	34	175	190	155	-	175
450	PN 25	20 × M 33	-	-	310	290	-	300
500	PN 10	20 × M 24	28	120	120	100	-	110
500	PN 16	20 × M 30	36	235	235	205	-	225
500	PN 25	20 × M 33	-	-	370	345	-	370
600	PN 10	20 × M 27	30	172	160	150	-	165
600 *	PN 16	20 × M 33	40	355	340	310	-	340
600	PN 25	20 × M 36	-	-	540	500	-	540

* Designed acc. to EN 1092-1 (not to DIN 2501)

Promag S screw tightening torques for ASME B16.5, Class 150/300

Promag S Nominal diameter [inch]	ASME Pressure rating	Threaded fasteners	Max. torque [lbf · ft]				
			Natural rubber	Polyurethan e	PTFE	PFA	Hard rubber
½"	Class 150	4 × ½"	-	-	4.4	-	-
½"	Class 300	4 × ½"	-	-	4.4	-	-
1"	Class 150	4 × ½"	-	5.2	8.1	7.4	-

Promag S Nominal diameter [inch]	ASME Pressure rating	Threaded fasteners	Max. torque [lbf · ft]				
			Natural rubber	Polyurethan e	PTFE	PFA	Hard rubber
1"	Class 300	4 × 5/8"	-	5.9	10	8.9	-
1½"	Class 150	4 × ½"	-	7.4	18	15	-
1½"	Class 300	4 × ¾"	-	11	25	23	-
2"	Class 150	4 × 5/8"	-	16	35	32	-
2"	Class 300	8 × 5/8"	-	8.1	17	16	-
3"	Class 150	4 × 5/8"	15	32	58	49	44
3"	Class 300	8 × ¾"	-	19	35	31	28
4"	Class 150	8 × 5/8"	11	23	41	37	31
4"	Class 300	8 × ¾"	-	30	49	44	43
6"	Class 150	8 × ¾"	24	44	78	63	58
6"	Class 300	12 × ¾"	-	38	54	49	52
8"	Class 150	8 × ¾"	38	59	105	80	79
10"	Class 150	12 × 7/8"	42	55	100	-	75
12"	Class 150	12 × 7/8"	58	76	131	-	98
14"	Class 150	12 × 1"	77	117	192	-	100
16"	Class 150	16 × 1"	75	111	181	-	94
18"	Class 150	16 × 1 1/8"	108	173	274	-	150
20"	Class 150	20 × 1 1/8"	105	160	252	-	135
24"	Class 150	20 × 1 1/4"	161	226	352	-	198

Promag S screw tightening torques for JIS B2220, 10/20K

Promag S Nominal diameter [mm]	JIS Pressure rating	Threaded fasteners	Max. tightening torque [Nm]				
			Natural rubber	Polyurethan e	PTFE	PFA	Hard rubber
15	10K	4 × M 12	-	-	16	-	-
15	20K	4 × M 12	-	-	16	-	-
25	10K	4 × M 16	-	19	32	27	-
25	20K	4 × M 16	-	19	32	27	-
32	10K	4 × M 16	-	22	38	-	-
32	20K	4 × M 16	-	22	38	-	-
40	10K	4 × M 16	-	24	41	37	-
40	20K	4 × M 16	-	24	41	37	-
50	10K	4 × M 16	-	33	54	46	-
50	20K	8 × M 16	-	17	27	23	-
65	10K	4 × M 16	18	45	74	63	55
65	20K	8 × M 16	-	23	37	31	28
80	10K	8 × M 16	10	23	38	32	29
80	20K	8 × M 20	-	35	57	46	42
100	10K	8 × M 16	12	29	47	38	35

Promag S Nominal diameter [mm]	JIS Pressure rating	Threaded fasteners	Max. tightening torque [Nm]				
			Natural rubber	Polyurethan e	PTFE	PFA	Hard rubber
100	20K	8 × M 20	–	48	75	58	56
125	10K	8 × M 20	20	51	80	66	60
125	20K	8 × M 22	–	79	121	103	91
150	10K	8 × M 20	25	63	99	81	75
150	20K	12 × M 22	–	72	108	72	81
200	10K	12 × M 20	23	52	82	54	61
200	20K	12 × M 22	–	80	121	88	91
250	10K	12 × M 22	39	87	133	–	100
250	20K	12 × M 24	–	144	212	–	159
300	10K	16 × M 22	38	63	99	–	74
300	20K	16 × M 24	–	124	183	–	138

Promag S screw tightening torques for JIS B2220, 10/20K

Nominal diameter [mm]	JIS Pressure rating	Threaded fasteners	Nom. tightening torque	
			Natural rubber [Nm]	Polyurethane [Nm]
350	10K	16 × M 22	109	109
350	20K	16 × M 30×3	217	217
400	10K	16 × M 24	163	163
400	20K	16 × M 30×3	258	258
450	10K	16 × M 24	155	155
450	20K	16 × M 30×3	272	272
500	10K	16 × M 24	183	183
500	20K	16 × M 30×3	315	315
600	10K	16 × M 30	235	235
600	20K	16 × M 36×3	381	381

Promag S screw tightening torques for AS 2129, Table E

Sensor Nominal diameter [mm]	AS 2129 Pressure rating	Threaded fasteners	Max. tightening torque [Nm]	
			PTFE	Natural rubber
25	Table E	4 × M 12	21	–
50	Table E	4 × M 16	42	–
80	Table E	4 × M 16	–	16
100	Table E	8 × M 16	–	13
150	Table E	8 × M 20	–	22
200	Table E	8 × M 20	–	36
250	Table E	12 × M 20	–	37
300	Table E	12 × M 24	–	57
350	Table E	12 × M 24	–	85
400	Table E	12 × M 24	–	99

Sensor Nominal diameter [mm]	AS 2129 Pressure rating	Threaded fasteners	Max. tightening torque [Nm]	
			PTFE	Natural rubber
450	Table E	16 × M 24	–	96
500	Table E	16 × M 24	–	115
600	Table E	16 × M 30	–	199

Promag S screw tightening torques for AS 4087, PN 16

Sensor Nominal diameter [mm]	AS 4087 Pressure rating	Threaded fasteners	Max. tightening torque [Nm]	
			PTFE	Natural rubber
50	PN 16	4 × M 16	42	–
80	PN 16	4 × M 16	–	16
100	PN 16	4 × M 16	–	13
150	PN 16	8 × M 16	–	20
200	PN 16	8 × M 16	–	33
250	PN 16	8 × M 20	–	64
300	PN 16	12 × M 20	–	55
350	PN 16	12 × M 24	–	91
400	PN 16	12 × M 24	–	113
450	PN 16	12 × M 24	–	144
500	PN 16	16 × M 24	–	131
600	PN 16	16 × M 27	–	204

Installing the high-temperature version (with PFA lining)

The high-temperature version has a housing support for the thermal separation of sensor and transmitter. The high-temperature version is always used for applications in which high ambient temperatures are encountered in conjunction with high fluid temperatures. The high-temperature version is obligatory if the fluid temperature exceeds +150 °C (+300 °F).



Note!

You will find information on permissible temperature ranges on → 102

Insulation

Pipes generally have to be insulated if they carry very hot fluids to avoid energy losses and prevent accidental contact with pipes at temperatures that could cause injury. Guidelines regulating the insulation of pipes have to be taken into account.



Caution!

Risk of electronics overheating. The housing support dissipates heat and its entire surface area must remain uncovered. Make sure that the sensor insulation does not extend past the top of the two sensor half-shells.

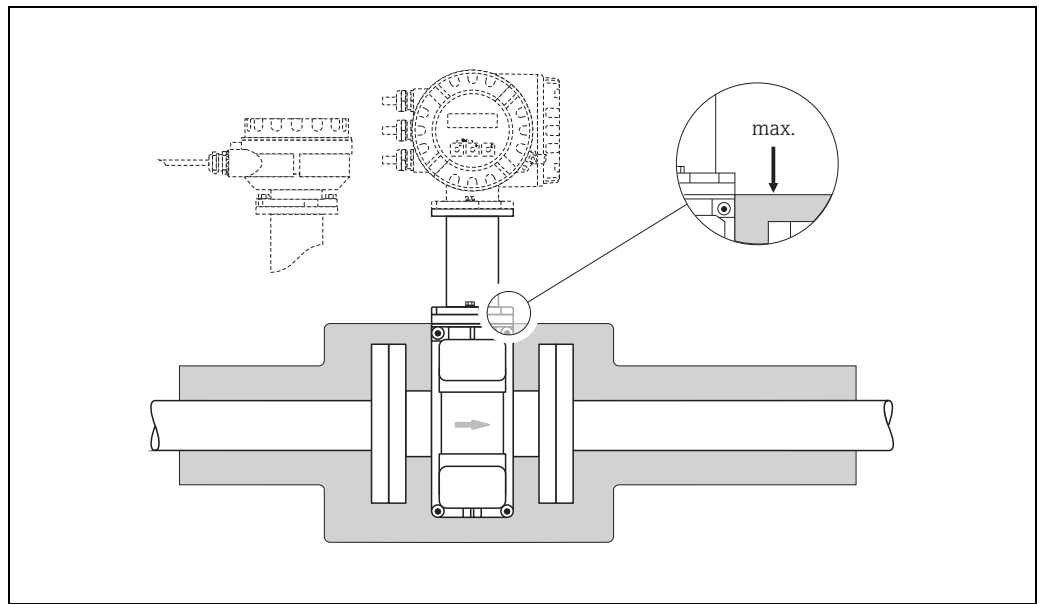

Fig. 19: Sensor (high-temperature version): insulating the pipe

a0004300

3.3.2 Installing the Promag H sensor

The Promag H is supplied to order, with or without pre-installed process connections. Pre-installed process connections are secured to the sensor with four or six hex-head threaded fasteners.



Caution!

- The sensor might require support or additional attachments, depending on the application and the length of the piping run. When plastic process connections are used, the sensor must be additionally supported mechanically. A wall-mounting kit can be ordered separately from Endress+Hauser as an accessory → 77.

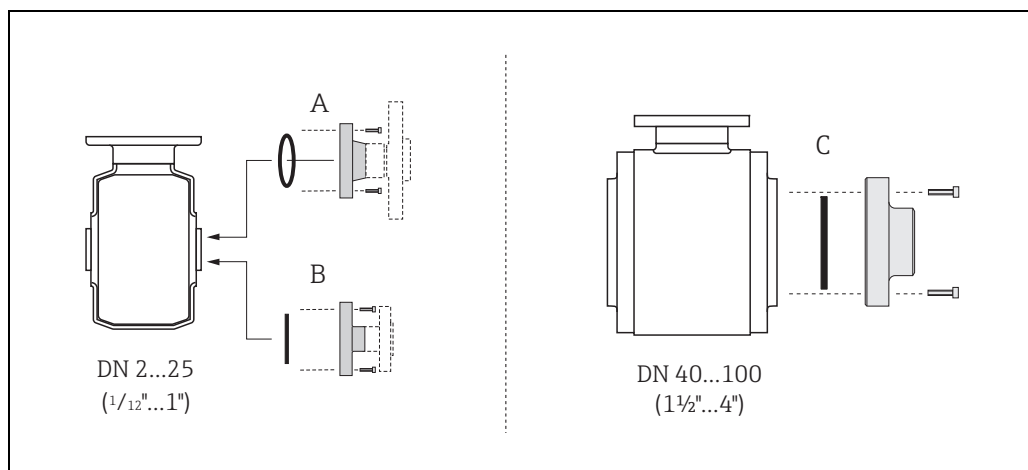

Fig. 20: Promag H process connections

A: DN 2 to 25 ($\frac{1}{12}$ to 1") / process connections with O-rings:
Welding flanges (DIN EN ISO 1127, ODT / SMS), flange (EN (DIN), ASME, JIS), flange PVDF (EN (DIN), ASME, JIS), external and internal pipe threads, hose connection, PVC adhesive fitting

B: DN 2 to 25 ($\frac{1}{12}$ to 1") / process connections with aseptic gasket seals:
Weld nipples (EN 10357 (DIN 11850), ODT/SMS), Clamp (ISO 2852, DIN 32676, L14 AM7), coupling (DIN 11851, DIN 11864-1, SMS 1145), flange DIN 11864-2

C: DN 40 to 100 ($1\frac{1}{2}$ to 4") / process connections with aseptic gasket seals:
Weld nipples (EN 10357 (DIN 11850), ODT/SMS), Clamp (ISO 2852, DIN 32676), L14 AM7), coupling (DIN 11851, DIN 11864-1, ISO 2853, SMS 1145), flange DIN 11864-2

Seals

When installing the process connections, make sure that the seals are clean and correctly centered.



Caution!

- With metallic process connections, you must fully tighten the screws. The process connection forms a metallic connection with the sensor, which ensures a defined compression of the seal.
- With plastic process connections, note the max. torques for lubricated threads (7 Nm / 5.2 lbf ft).
With plastic flanges, always use seals between connection and counter flange.
- The seals must be replaced periodically, depending on the application, particularly in the case of gasket seals (aseptic version)! The period between changes depends on the frequency of cleaning cycles, the cleaning temperature and the fluid temperature. Replacement seals can be ordered as accessories → 77.

Usage and assembly of ground rings (DN 2 to 25 / 1/12 to 1")

In case the process connections are made of plastic (e.g. flanges or adhesive fittings), the potential between the sensor and the fluid must be equalized using additional ground rings. If the ground rings are not installed this can affect the accuracy of the measurements or cause the destruction of the sensor through the galvanic corrosion of the electrodes.



Caution!

- Depending on the option ordered, plastic rings may be installed at the process connections instead of ground rings. These plastic rings serve only as spacers and have no potential equalization function. In addition, they provide a sealing function at the interface between the sensor and process connection. For this reason, with process connections without ground rings, these plastic rings/seals must not be removed, or must always be installed.
- Ground rings can be ordered separately from Endress+Hauser as accessories → 77. When placing the order, make certain that the ground ring is compatible with the material used for the electrodes. Otherwise, there is a risk that the electrodes may be destroyed by galvanic corrosion! Information about the materials can be found on → 108.
- Ground rings, including the seals, are mounted within the process connections. Therefore, the fitting length is not affected.

1. Loosen the four or six hexagonal headed bolts (1) and remove the process connection from the sensor (4).
2. Remove the plastic ring (3), including the two O-ring seals (2).
3. Place one seal (2) in the groove of the process connection.
4. Place the metal ground ring (3) on the process connection.
5. Now place the second seal (2) in the groove of the ground ring.
6. Finally, mount the process connection on the sensor again. With plastic process connections, note the max. torques for lubricated threads (7 Nm / 5.2 lbf ft).

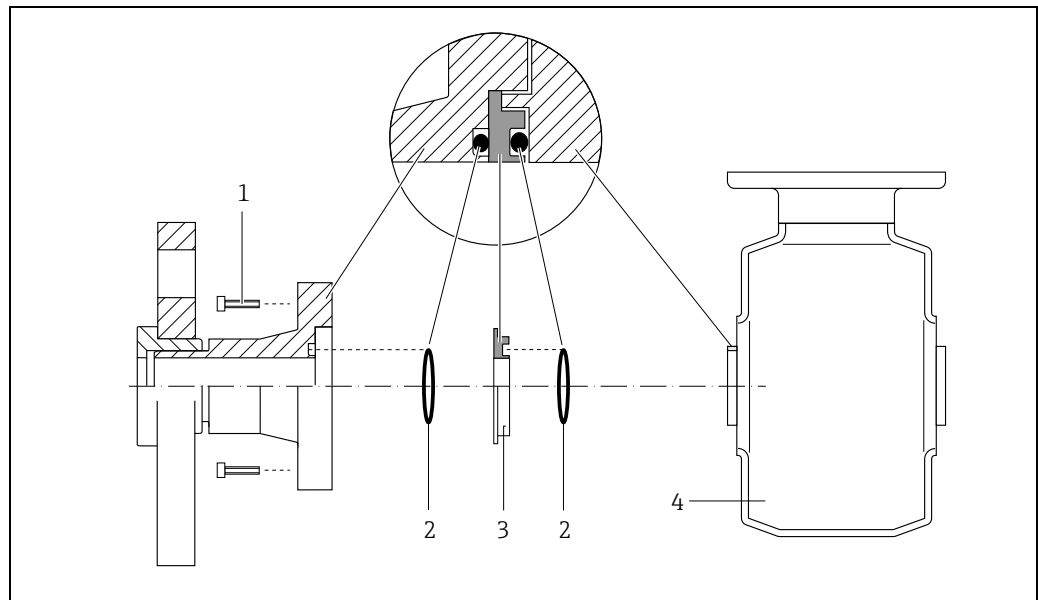

Fig. 2.1: Installing ground rings with a Promag H (DN 2 to 25 / 1/12 to 1")

- 1 = Hexagonal-headed bolts, process connection
 2 = O-ring seals
 3 = Grounding ring or plastic ring (spacer)
 4 = Sensor

Welding the sensor into the piping (weld nipples)



Caution!

Risk of destroying the measuring electronics. Make sure that the welding machine is not grounded via the sensor or the transmitter.

1. Tack-weld the Promag H sensor into the pipe. A suitable welding jig can be ordered separately from Endress+Hauser as an accessory → 77.
1. Remove the threaded fasteners from the process-connection flange. Remove the sensor complete with seal from the pipe.
2. Weld the process connection to the pipe.
3. Reinstall the sensor in the pipe. Make sure that everything is clean and that the seal is correctly seated.



Note!

- If thin-walled foodstuffs pipes are not welded correctly, the heat could damage the installed seal. It is therefore advisable to remove the sensor and the seal prior to welding.
- The pipe has to be spread approximately 8 mm to permit disassembly.

Cleaning with pigs

If pigs are used for cleaning, it is essential to take the inside diameters of measuring tube and process connection into account.

All the dimensions and lengths of the sensor and transmitter are provided in the separate documentation "Technical Information".

3.3.3 Turning the transmitter housing

Turning the aluminum field housing



Warning!

The turning mechanism in devices with Ex d/de or FM/CSA Cl. I Div. 1 classification is not the same as that described here. The procedure for turning these housings is described in the Ex-specific documentation.

1. Loosen the two securing screws.
2. Turn the bayonet catch as far as it will go.
3. Carefully lift the transmitter housing as far as it will go.
4. Turn the transmitter housing to the desired position (max. $2 \times 90^\circ$ in either direction).
5. Lower the housing into position and reengage the bayonet catch.
6. Retighten the two securing screws.

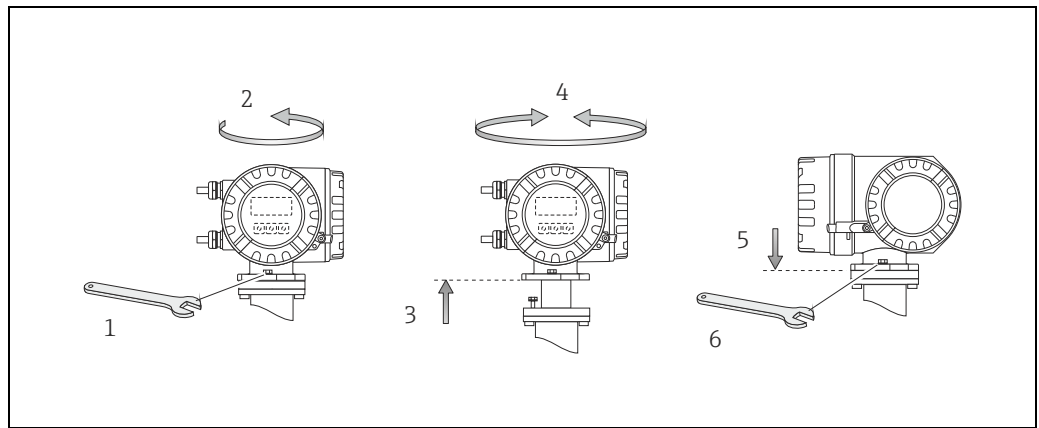

Fig. 22: Turning the transmitter housing (aluminum field housing)

Turning the stainless steel field housing

- a. Loosen the two securing screws.
- b. Carefully lift the transmitter housing as far as it will go.
- c. Turn the transmitter housing to the desired position (max. $2 \times 90^\circ$ in either direction).
- d. Lower the housing into position once more.
- e. Retighten the two securing screws.

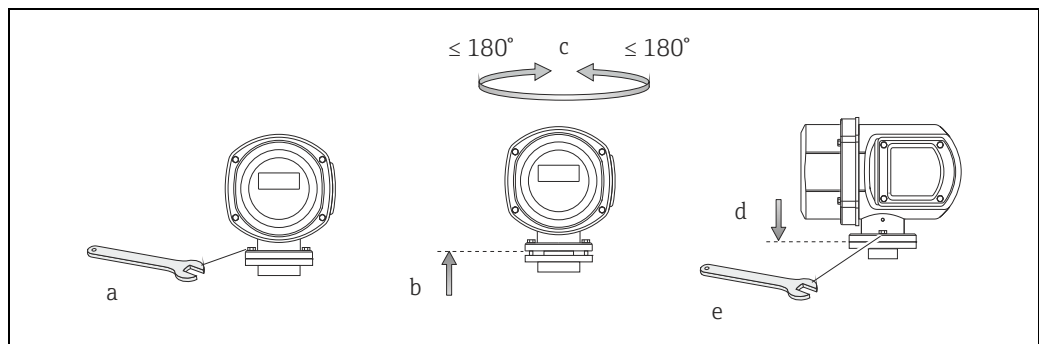

Fig. 23: Turning the transmitter housing (stainless steel field housing)

3.3.4 Turning the local display

1. Unscrew the electronics compartment cover from the transmitter housing.
2. Press the latches on the side of the display module and pull the module out of the electronics compartment cover.
3. Turn the display to the desired position (max. $4 \times 45^\circ$ in both directions) and position it back on the electronics compartment cover.
4. Screw the cover of the electronics compartment firmly onto the transmitter housing.

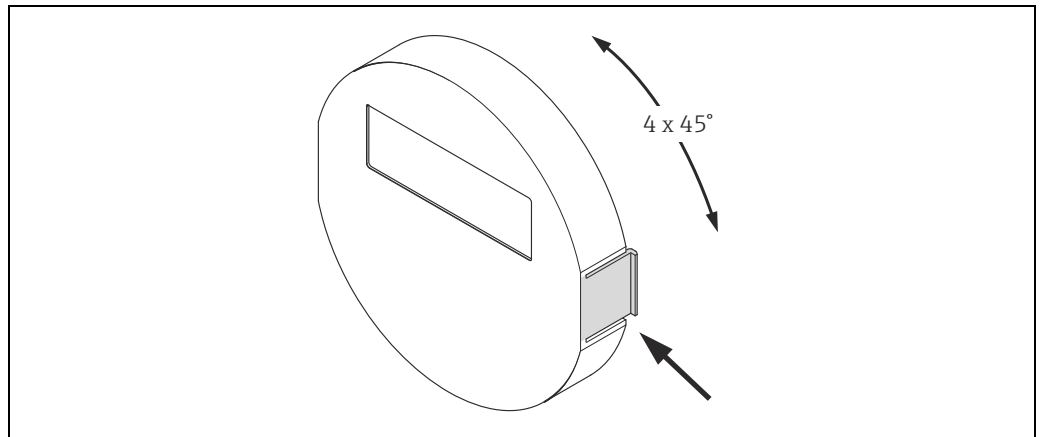

Fig. 24: Turning the local display (field housing)

a0003236

3.3.5 Installing the wall-mount housing

There are various ways of installing the wall-mount housing:

- Mounted directly on the wall
- Panel mounting (with separate mounting kit, accessories) → 33
- Pipe mounting (with separate mounting kit, accessories) → 33



Caution!

- Make sure that the permitted ambient temperature range is observed (see nameplate or → 101). Install the device in a shady location. Avoid direct sunlight.
- Always install the wall-mount housing in such a way that the cable entries are pointing down.

Mounted directly on the wall

1. Drill the holes as illustrated.
2. Remove the cover of the connection compartment (a).
3. Push the two securing screws (b) through the appropriate bores (c) in the housing.
 - Securing screws (M6): max. \varnothing 6.5 mm (0.26")
 - Screw head: max. \varnothing 10.5 mm (0.4")
4. Secure the transmitter housing to the wall as indicated.
5. Screw the cover of the connection compartment (a) firmly onto the housing.

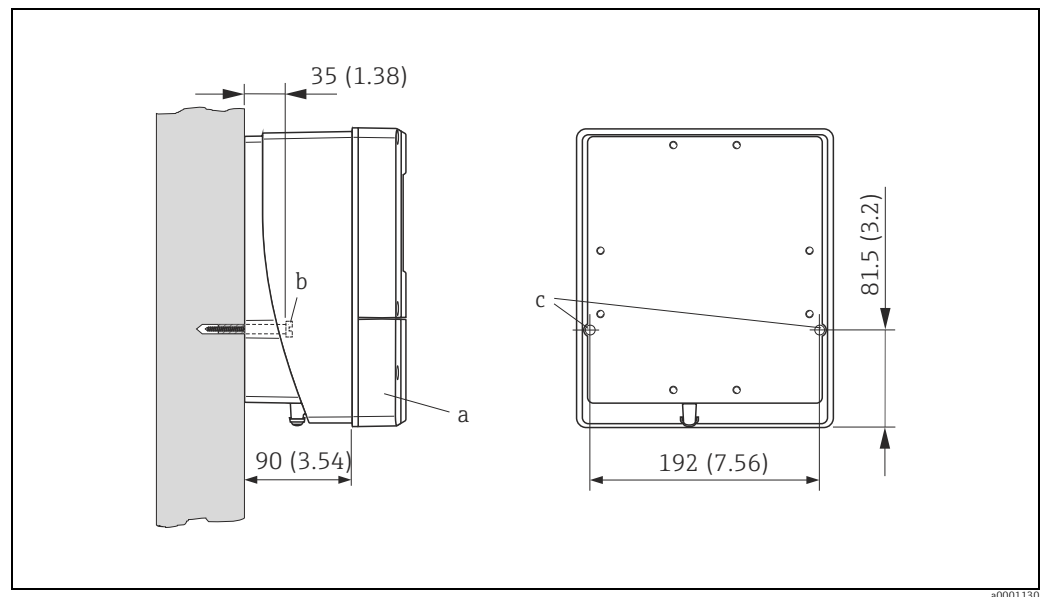

Fig. 25: Mounted directly on the wall. Engineering unit mm (in)

Panel mounting

1. Prepare the opening in the panel as illustrated.
2. Slide the housing into the opening in the panel from the front.
3. Screw the fasteners onto the wall-mount housing.
4. Place the threaded rods in the fasteners and screw them down until the housing is seated tightly against the panel wall. Afterwards, tighten the locking nuts.
Additional support is not necessary.

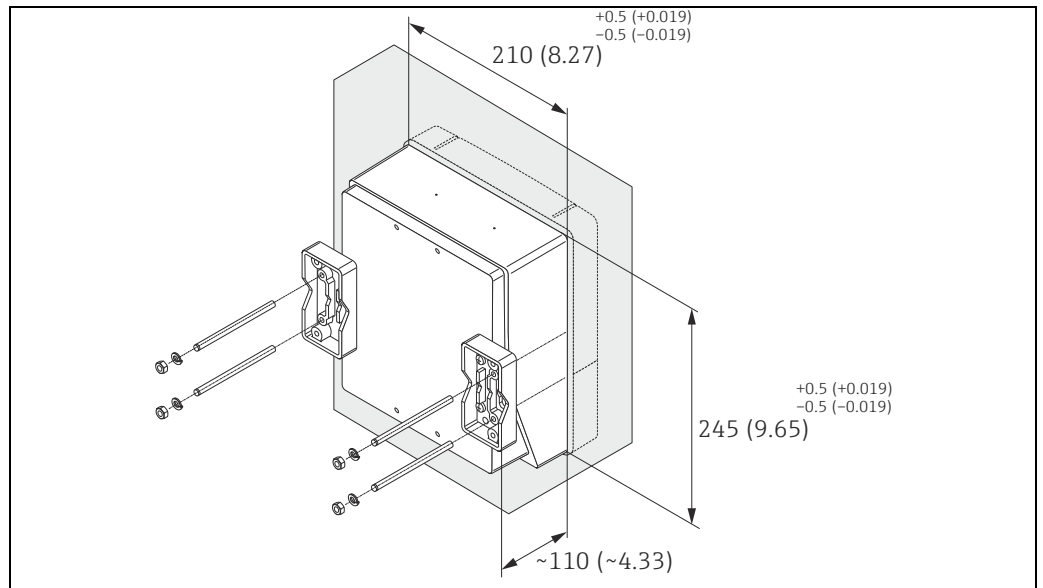

Fig. 26: Panel mounting (wall-mount housing). Engineering unit mm (in)

Pipe mounting

The assembly should be performed by following the instructions in the following diagram.



Caution!

If the device is mounted to a warm pipe, make sure that the housing temperature does not exceed +60 °C (+140 °F), which is the maximum permissible temperature.

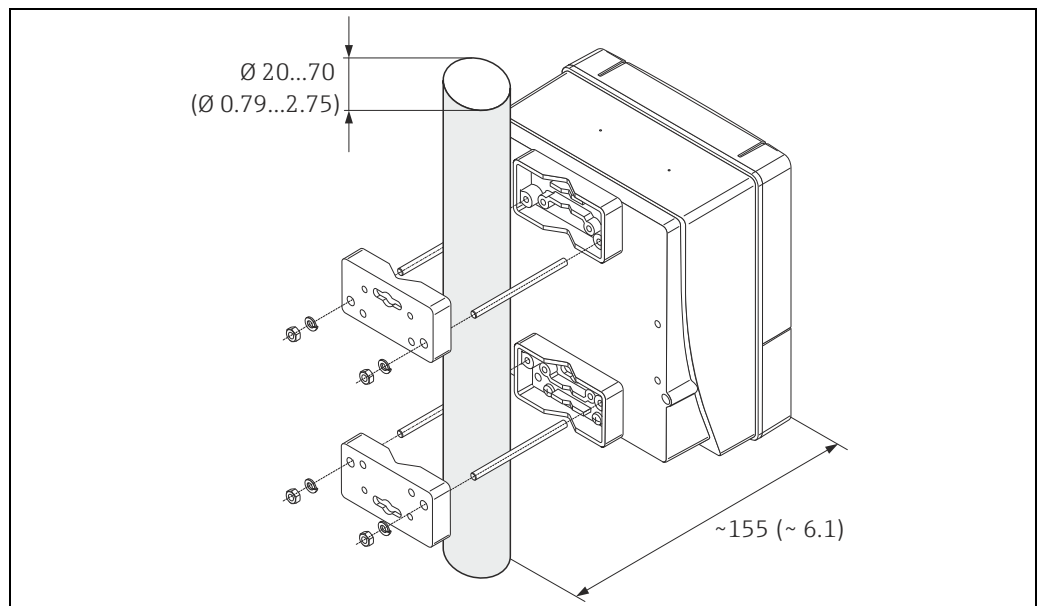

Fig. 27: Pipe mounting (wall-mount housing). Engineering unit mm (in)

3.4 Post-installation check

Perform the following checks after installing the measuring device in the pipe:

Device condition/specifications	Notes
Is the device damaged (visual inspection)?	-
Does the device correspond to specifications at the measuring point, including process temperature and pressure, ambient temperature, minimum fluid conductivity, measuring range, etc.?	→ 97
Installation	Notes
Does the arrow on the sensor nameplate match the direction of flow through the pipe?	-
Is the position of the measuring electrode plane correct?	→ 14
Is the position of the empty pipe detection electrode correct?	→ 14
Were all screws tightened to the specified torques when the sensor was installed?	→ 20
Were the correct seals installed (type, material, installation)?	→ 20
Are the measuring point number and labeling correct (visual inspection)?	-
Process environment / process conditions	Notes
Are the inlet and outlet runs respected?	Inlet run $\geq 5 \times \text{DN}$ Outlet run $\geq 2 \times \text{DN}$
Is the measuring device protected against moisture and direct sunlight?	-
Is the sensor adequately protected against vibration (attachment, support)?	Acceleration up to 2 g in accordance with IEC 600 68-2-6 → 102

4 Wiring



Warning!

- When connecting Ex-certified devices, please take note of the instructions and wiring diagrams in the Ex-specific supplement to these Operating Instructions. Should you have any questions, please contact your Endress+Hauser sales office for assistance.
- When installing remote versions, please make sure that the serial number on the sensor and the serial number on the transmitter are *identical*. Measuring errors can occur if this is not adhered to.



Note!

The device does not have an internal circuit breaker. An external switch or circuit breaker must therefore be installed which can be used to disconnect the device from the main power source.

4.1 FOUNDATION Fieldbus cable specification

4.1.1 Cable type

Twin-core cable is recommended for connecting the flowmeter to the FOUNDATION Fieldbus H1. In accordance with IEC 61158-2 (MBP), four different cable types (A, B, C, D) can be used with the FOUNDATION Fieldbus Protocol, only two of which (cable types A and B) are shielded.

- Cable types A or B are particularly preferable for new installations. Only these types have cable shielding that guarantees adequate protection from electromagnetic interference and thus the most reliable data transfer. With cable type B more than one fieldbus (with the same degree of protection) may be operated in a cable. No other circuits are permissible in the same cable.
- Practical experience has shown that cable types C and D should not be used due to the lack of shielding, since the freedom from interference generally does not meet the requirements described in the standard.

The electrical data of the fieldbus cable have not been specified. However, they determine important characteristics of the design of the fieldbus, such as distances bridged, number of users, electromagnetic compatibility, etc.

	Type A	Type B
Cable structure	Twisted pair, shielded	One or more twisted pairs, fully shielded
Wire cross-section	0.8 mm ² (AWG 18)	0.32 mm ² (AWG 22)
Loop-resistance (DC)	44 Ω/km	112 Ω/km
Characteristic impedance at 31.25 kHz	100 Ω ± 20%	100 Ω ± 30%
Attenuation constant at 39 kHz	3 dB/km	5 dB/km
Capacitive asymmetry	2 nF/km	2 nF/km
Envelope delay distortion (7.9 to 39 kHz)	1.7 μs/km	*
Shield coverage	90%	*
Max. cable length (incl. spurs >1 m)	1900 m (6233 ft)	1200 m (3937 ft)
* Not specified		

Suitable fieldbus cables (Type A) from various manufacturers for non-hazardous areas are listed below:

- Siemens: 6XV1 830-5BH10
- Belden: 3076F
- Kerpen: CeL-PE/OSCR/PVC/FRLA FB-02YS(ST)YFL

4.1.2 Maximum overall cable length

The maximum network expansion depends on the type of protection and the cable specifications. The overall cable length combines the length of the main cable and the length of all spurs (>1 m/3.28 ft). Note the following points:

- The maximum permissible overall cable length depends on the cable type used.
- If repeaters are used, the maximum permissible cable length is doubled. A maximum of three repeaters are permitted between user and master.

4.1.3 Maximum spur length

The line between the distribution box and field device is described as a spur. In the case of non-Ex applications, the max. length of a spur depends on the number of spurs (>1 m/3.28 ft):

Number of spurs	1 to 12	13 to 14	15 to 18	19 to 24	25 to 32
Max. length per spur	120 m (393 ft)	90 m (295 ft)	60 m (196 ft)	30 m (98 ft)	1 m (3.28 ft)

4.1.4 Number of field devices

According to IEC 61158-2 (MBP) a maximum of 32 field devices may be connected per fieldbus segment. However, this number may be restricted in certain circumstances (type of ignition protection, bus power option, current consumption of field device).

A maximum of four field devices can be connected to a spur.

4.1.5 Shielding and grounding

The optimum electromagnetic compatibility of the fieldbus system is guaranteed only when system components and in particular lines are shielded and the shielding provides the most complete coverage possible. Shield coverage of 90% is ideal.

Shielding should be connected as often as possible with the reference ground. The national regulations and guidelines governing the installation of electrical equipment also apply where relevant!

Where there are large differences in potential between the individual grounding points, only one point of the shielding is connected directly with the reference ground. In systems without potential equalization, cable shielding of fieldbus systems should therefore only be grounded on one side, for example at the fieldbus supply unit or at safety barriers.



Caution!

If the cable shielding is grounded at more than one point in systems without potential equalization, network frequency equalization currents can occur that damage the bus cable or the bus shielding and substantially affect signal transmission.

4.1.6 Bus termination

The start and end of each fieldbus segment are always to be terminated with a bus terminator. With various junction boxes (non-Ex), the bus termination can be activated via a switch. If this is not the case, a separate bus terminator must be installed. Please also note the following points:

- In the case of a branched bus segment, the device furthest from the segment coupler constitutes the end of the bus.
- If the fieldbus is extended with a repeater then the extension must also be terminated at both ends.

4.1.7 Further information

General information and further notes on connections can be found on the website (www.fieldbus.org) of the Fieldbus Foundation or in the Operating Instructions "FOUNDATION Fieldbus Overview" (available at: → www.endress.com → Download).

4.2 Shielding and grounding

When planning the shielding and grounding for a fieldbus system, there are three important points to consider:

- Electromagnetic compatibility (EMC)
- Explosion protection
- Safety of the personnel

To ensure the optimum electromagnetic compatibility of systems, it is important that the system components and above all the cables, which connect the components, are shielded and that no portion of the system is unshielded. Ideally, the cable shields are connected to the normally metal housings of the connected field devices. Since these are generally connected to the protective earth, the shield of the bus cable is grounded many times. Keep the stripped and twisted lengths of cable shield to the terminals as short as possible.

This approach, which provides the best electromagnetic compatibility and personal safety, can be used without restriction in systems with good potential matching.

In the case of systems without potential matching, a power supply frequency (50 Hz) equalizing current can flow between two grounding points which, in unfavorable cases, e.g. when it exceeds the permissible shield current, may destroy the cable.

To suppress the low frequency equalizing currents on systems without potential equalization, it is therefore recommended to connect the cable shield directly to the building ground (or protective earth) at one end only and to use capacitive coupling to connect all other grounding points.



Caution!

The legal EMC requirements are fulfilled **only** when the cable shield is grounded on both sides!

4.3 Connecting the remote version



Warning!

- Risk of electric shock. Switch off the power supply before opening the device. Do **not** install or wire the device while it is connected to the power supply. Failure to comply with this precaution can result in irreparable damage to the electronics.
- Risk of electric shock. Connect the protective conductor to the ground terminal on the housing before the power supply is applied.



Caution!

- Only sensors and transmitters with the same serial number may be connected with each other. Communication problems may occur if this is not adhered to.
- Risk of damaging the coil driver. Do not connect or remove the coil current cable until the power supply has been switched off.

4.3.1 Connecting the sensor

Procedure

1. Transmitter: Remove the cover from the connection compartment (a).
2. Sensor: Remove the cover from the connection housing (b).
3. Feed the electrode cable (c) and coil current cable (d) through the appropriate cable entries.



Caution!

Secure the connecting cable (see "Length of connecting cable" → 101).

4. Terminate the electrode and coil current cable in accordance with the table:
Promag S → Please see the "Cable termination" table → 40
Promag H → Please see the "Cable termination" table → 41
5. Set up the wiring between the sensor and the transmitter.
The wiring diagram applicable to your device can be found:
 - in the relevant diagram:
 - 28 (Promag S); → 29 (Promag H)
 - in the cover of the sensor and transmitter.



Note!

The cable shields of the Promag H sensor are grounded using strain relief clamps → 29.



Caution!

Insulate the cable shields that are not connected. This eliminates the risk of short-circuits with neighboring cable shields inside the connection housing.

6. Transmitter: Secure the cover on the connection compartment (a).
7. Sensor: Mount the cover on the connection housing (b).

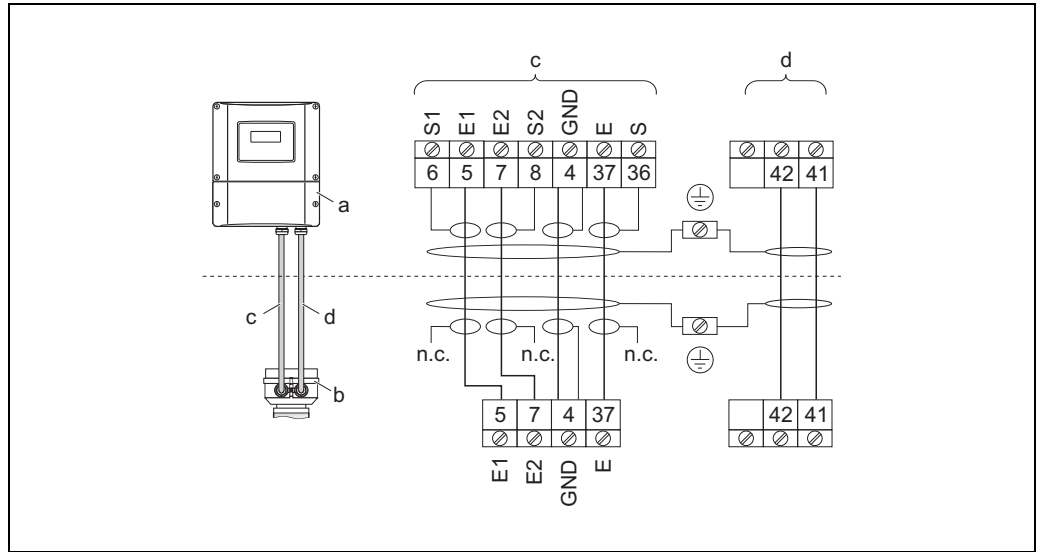

A0011722

Fig. 28: Connecting the remote version of the Promag S

- a Connection compartment, wall-mount housing
- b Connection housing, sensor
- c Electrode cable
- d Coil current cable
- n.c. Not connected, insulated cable shields
- n.c. Cable colors/numbers for terminals:
5/6 = brown, 7/8 = white, 4 = green, 37/36 = yellow

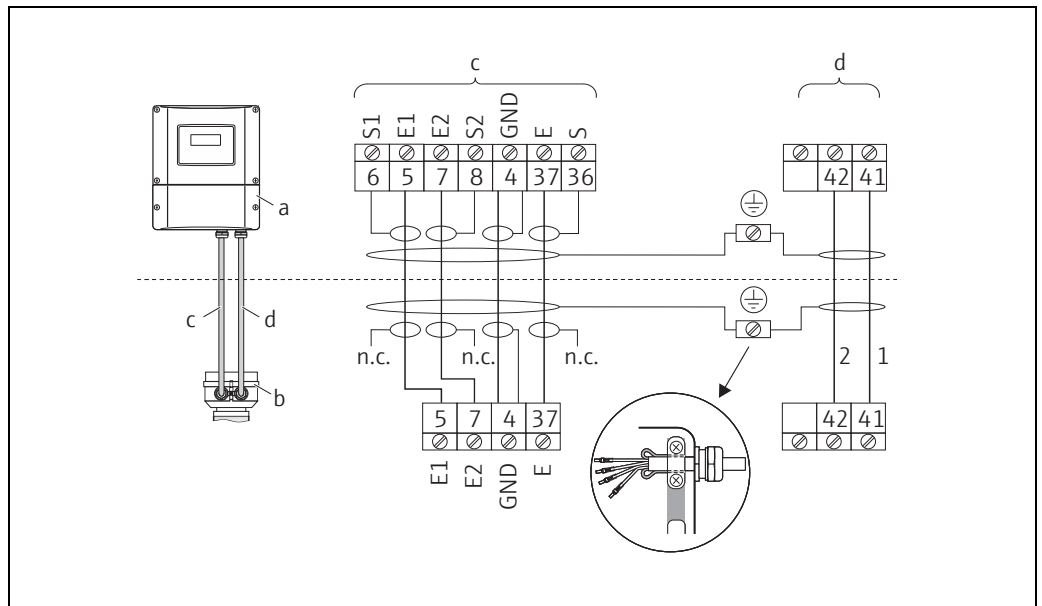

A0011747

Fig. 29: Connecting the remote version of the Promag H

- a Connection compartment, wall-mount housing
- b Connection housing, sensor
- c Electrode cable
- d Coil current cable
- n.c. Not connected, insulated cable shields
- n.c. Cable colors/numbers for terminals:
5/6 = brown, 7/8 = white, 4 = green, 37/36 = yellow

**Cable termination in remote version
Promag S**

Terminate the signal and coil current cables as shown in the figure below (Detail A).
Fit the fine-wire cores with wire end ferrules (Detail B).

Caution!

When fitting the connectors, pay attention to the following points:

- *Electrode cable* → Make sure that the wire end ferrules do not touch the wire shields on the sensor side!
Minimum distance = 1 mm / 0.04" (exception "GND" = green cable)
- *Coil current cable* → Insulate one core of the three-core wire at the level of the core reinforcement; you only require two cores for the connection.

TRANSMITTER

Electrode cable

Coil current cable

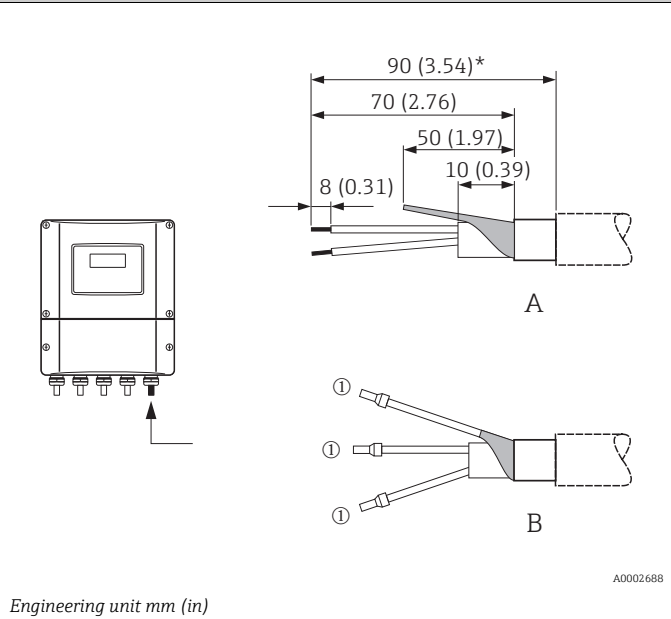
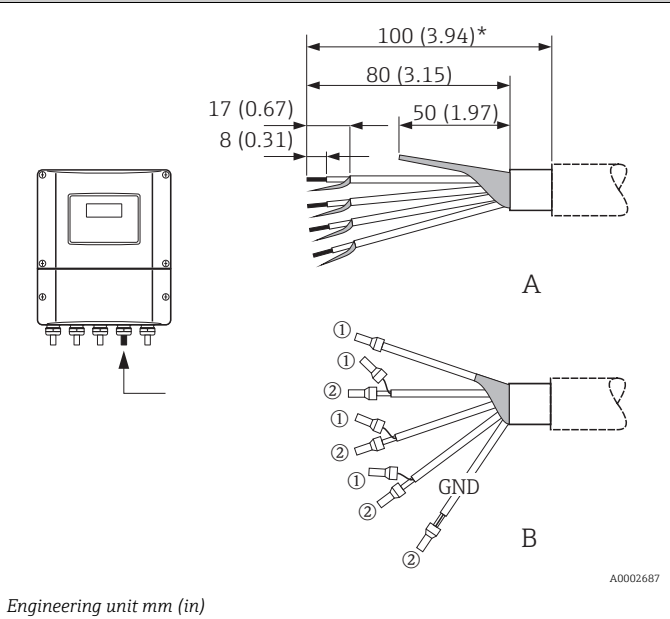

SENSOR

Electrode cable

Coil current cable

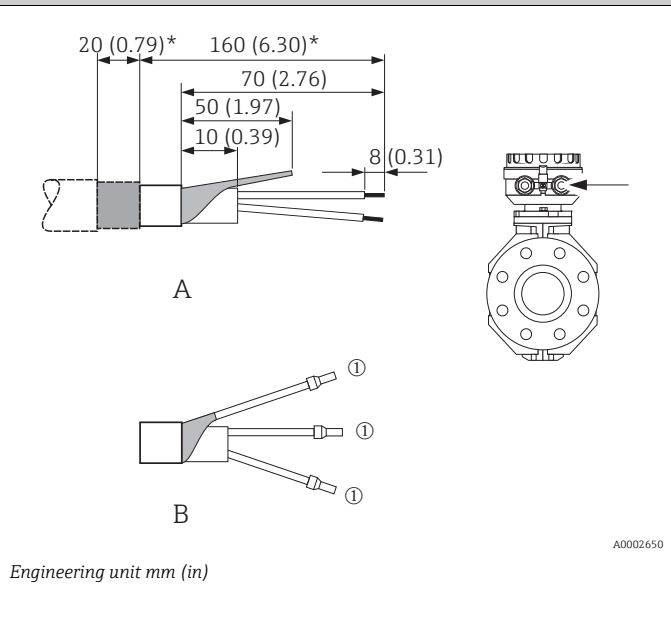
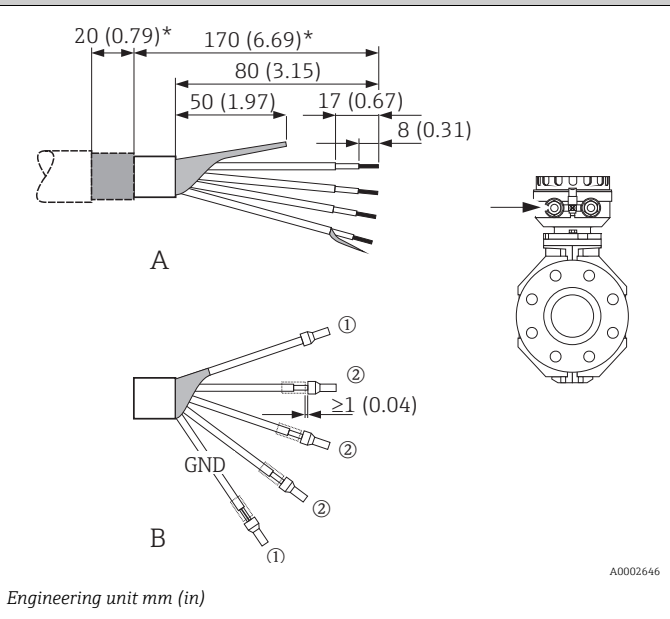

- ① = Cable end sleeve red, Ø 1.0 mm (0.04 in)
- ② = Cable end sleeve white, Ø 0.5 mm (0.02 in)
- * = Stripping for armored cables only

**Cable termination in remote version
Promag H**

Terminate the signal and coil current cables as shown in the figure below (Detail A).
Fit the fine-wire cores with wire end ferrules (detail B: ① = ferrules red, Ø 1.0 mm; ② = ferrule white, Ø 0.5 mm)

⚠ Caution!

When fitting the connectors, pay attention to the following points:

- **Electrode cable** → Make sure that the wire end ferrules do not touch the wire shields on the sensor side!
Minimum distance = 1 mm / " (exception "GND" = green cable)
- **Coil current cable** → Insulate one core of the three-core wire at the level of the core reinforcement; you only require two cores for the connection.
- On the sensor side, reverse both cable shields approx. 15 mm over the outer jacket. The strain relief ensures an electrical connection with the connection housing.

TRANSMITTER

Electrode cable

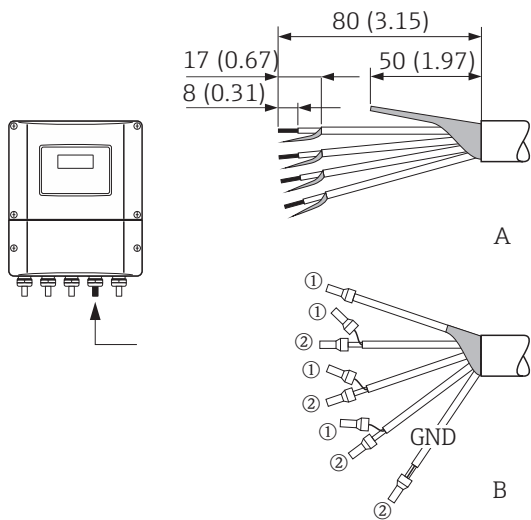

A0002686

Engineering unit mm (in)

Coil current cable

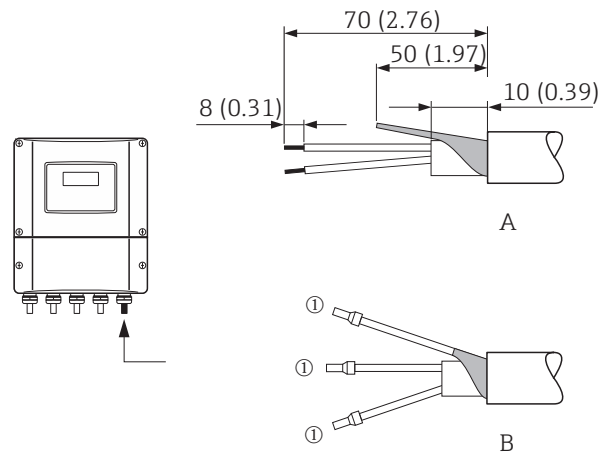

A0002684

Engineering unit mm (in)

SENSOR

Electrode cable

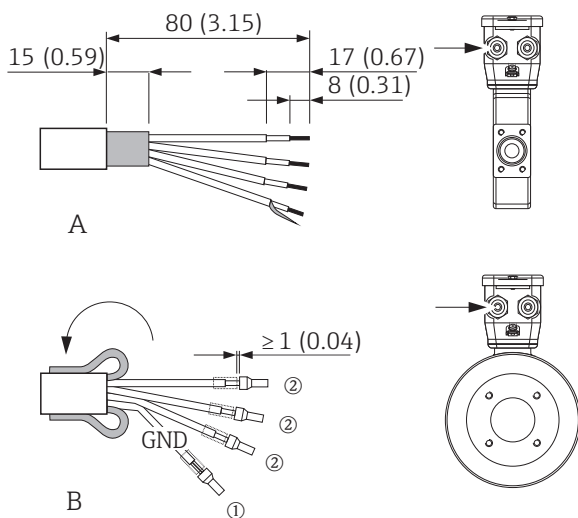

A0002647

Engineering unit mm (in)

Coil current cable

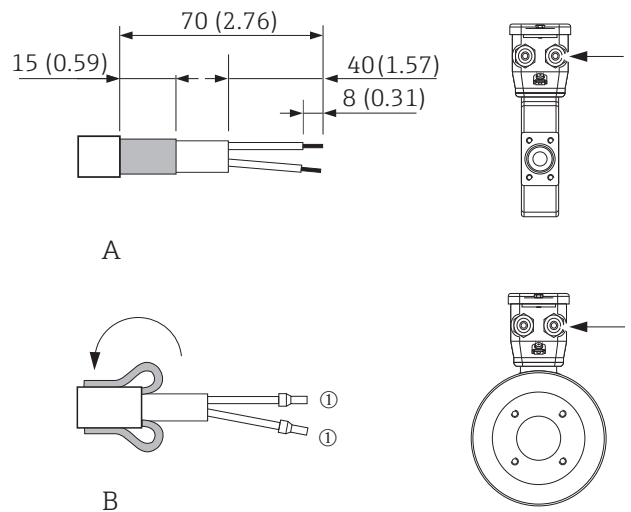

A0002648

Engineering unit mm (in)

4.3.2 Cable specifications

Coil current cable

- $3 \times 0.75 \text{ mm}^2$ (18 AWG) PVC cable with common, braided copper shield ($\varnothing \sim 9 \text{ mm}/0.35''$)
- Conductor resistance: $\leq 37 \text{ } \Omega/\text{km}$ ($\leq 0.011 \text{ } \Omega/\text{ft}$)
- Capacitance: core/core, shield grounded: $\leq 120 \text{ pF/m}$ ($\leq 37 \text{ pF/ft}$)
- Operating temperature:
 - Cable not permanently routed: -20 to $+80 \text{ } ^\circ\text{C}$ (-4 to $+176 \text{ } ^\circ\text{F}$)
 - Cable permanently routed: -40 to $+80 \text{ } ^\circ\text{C}$ (-40 to $+176 \text{ } ^\circ\text{F}$)
- Cable cross-section: max. 2.5 mm^2 (14 AWG)

Electrode cable

- $3 \times 0.38 \text{ mm}^2$ (20 AWG) PVC cable with common, braided copper shield ($\varnothing \sim 9.5 \text{ mm}/0.37''$) and individually shielded cores
- With Empty Pipe Detection (EPD): $4 \times 0.38 \text{ mm}^2$ (20 AWG) PVC cable with common, braided copper shield ($\varnothing \sim 9.5 \text{ mm}/0.37''$) and individually shielded cores
- Conductor resistance: $\leq 50 \text{ } \Omega/\text{km}$ ($\leq 0.015 \text{ } \Omega/\text{ft}$)
- Capacitance: core/shield: $\leq 420 \text{ pF/m}$ ($\leq 128 \text{ pF/ft}$)
- Operating temperature:
 - Cable not permanently routed: -20 to $+80 \text{ } ^\circ\text{C}$ (-4 to $+176 \text{ } ^\circ\text{F}$)
 - Cable permanently routed: -40 to $+80 \text{ } ^\circ\text{C}$ (-40 to $+176 \text{ } ^\circ\text{F}$)
- Cable cross-section: max. 2.5 mm^2 (14 AWG)

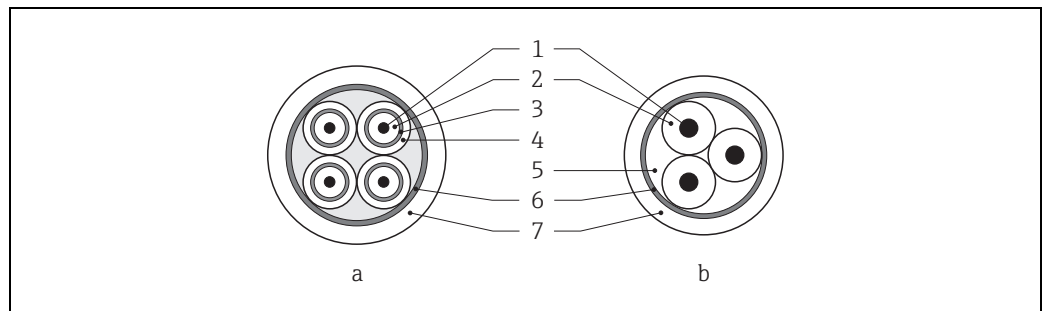

Fig. 30: Cable cross-section

- a Electrode cable
b Coil current cable

- 1 Core
2 Core insulation
3 Core shield
4 Core jacket
5 Core reinforcement
6 Cable shield
7 Outer jacket

Reinforced connecting cables

As an option, Endress+Hauser can also deliver reinforced connecting cables with an additional reinforcing metal braid. We recommend such cables for the following cases:

- Cables laid directly into the ground
- Rodent damage to cables
- Device operation which should comply with the IP 68 (NEMA 6P) standard of protection

Operation in zones of severe electrical interference

The measuring device complies with the general safety requirements in accordance with EN 61010-1, the EMC requirements of EN 61326/A1 and NAMUR recommendation NE 21.





Caution!

Grounding of the shield is by means of the ground terminals provided for the purpose inside the connection housing. Keep the stripped and twisted lengths of cable shield to the terminals as short as possible.

4.4 Connecting the measuring unit

Field instruments can be connected to the FOUNDATION Fieldbus in two ways:

- Connection via conventional cable gland →  43
- Connection using prefabricated fieldbus connector (option) →  45

4.4.1 Connecting the transmitter



Warning!

- Risk of electric shock. Switch off the power supply before opening the device. Do not install or wire the device while it is connected to the power supply. Failure to comply with this precaution can result in irreparable damage to the electronics.
- Risk of electric shock. Connect the protective earth to the ground terminal on the housing before the power supply is applied (e.g. galvanically isolated power supply SELV or PELV).
- Compare the specifications on the nameplate with the local voltage supply and frequency. Also observe the national regulations governing the installation of electrical equipment.

Procedure (→  31):

1. Unscrew the connection compartment cover (a) from the transmitter housing.
2. Feed the power supply cable (b) and fieldbus cable (d) through the appropriate cable entries.

 Note!

The device can also be supplied with the option of a ready-mounted fieldbus connector. More information on this can be found on →  45.

3. Perform wiring in accordance with the respective terminal assignment and the associated wiring diagram.

 Caution!

- Risk of damage to the fieldbus cable!
Observe the information about shielding and grounding the fieldbus cable →  37.
- We recommend that the fieldbus cable not be looped using conventional cable glands. If, at a later stage, you replace even just one measuring device, the bus communication will have to be interrupted.

 Note!

- The terminals for the fieldbus connection (26/27) have integrated reverse polarity protection. This ensures correct signal transmission via the fieldbus even if lines are transposed.
 - Conductor cross-section: max. 2.5 mm²
 - Between the stripped fieldbus cable shielding and the ground terminal (e), the cable shielding should not exceed a length of 5 mm.
4. Screw the cover of the connection compartment (a) back onto the transmitter housing.

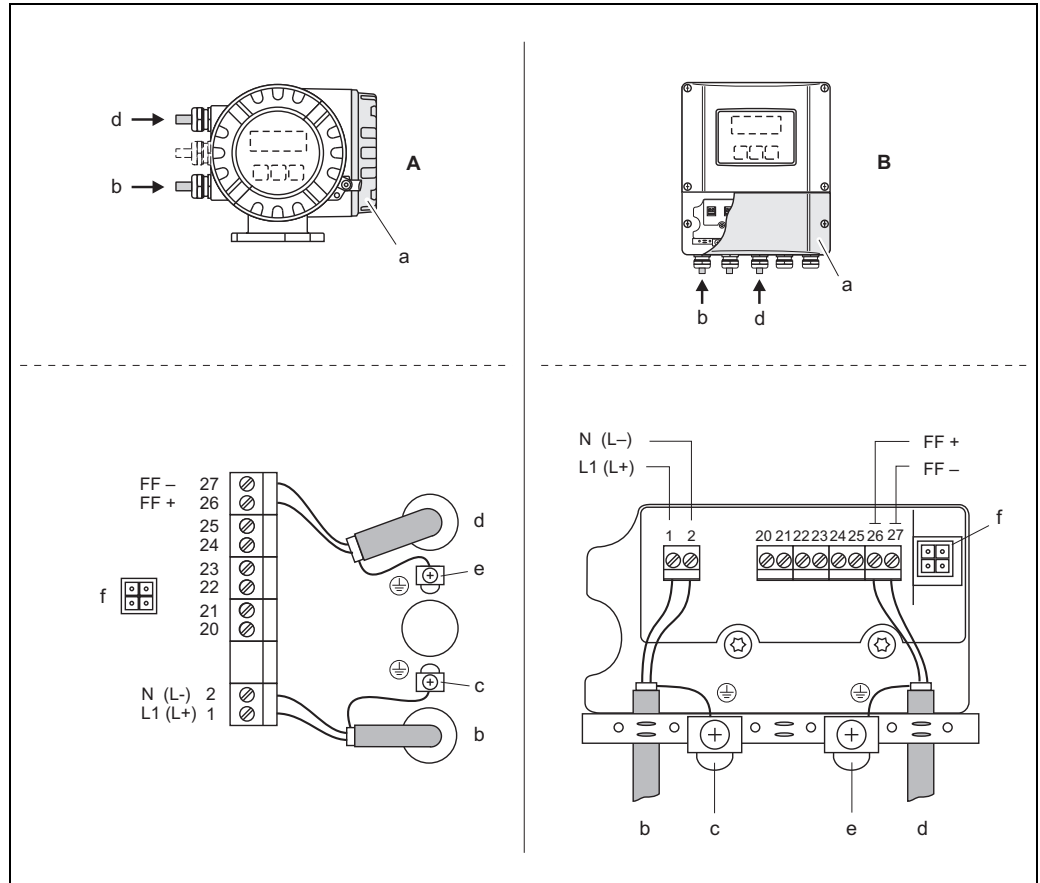

Fig. 31: Connecting the transmitter, cable cross-section: max. 2.5 mm²

- A View A (field housing)
 B View B (wall-mount housing)
 a Connection compartment cover
 b Cable for power supply
 Terminal no. 1:
 - L1 for AC, L+ for DC
 Terminal no. 2:
 - N for AC, L- for DC
 c Ground terminal for protective ground
 d Fieldbus cable
 Terminal no. 26:
 - FF + (with reverse polarity protection)
 Terminal no. 27:
 - FF - (with reverse polarity protection)
 e Fieldbus cable shield ground terminal
 Observe the following:
 - The shielding and grounding of the fieldbus cable → 37
 - Ensure the stripped and twisted lengths of cable shield to the ground terminal are as short as possible
 f Service connector for connecting the service interface FXA193 (Fieldcheck, FieldCare)

4.4.2 Fieldbus connector

The connection technology of FOUNDATION Fieldbus allows measuring devices to be connected to the fieldbus via uniform mechanical connections such as T-boxes, junction boxes, etc.

This connection technology using prefabricated distribution modules and plug-in connectors offers substantial advantages over conventional wiring:

- Field devices can be removed, replaced or added at any time during normal operation. Communication is not interrupted.
- Installation and maintenance are significantly easier.
- Existing cable infrastructures can be used and expanded instantly, e.g. when constructing new star distributors using 4-channel or 8-channel distribution modules.

The device can therefore be supplied with the option of a ready-mounted fieldbus connector. Fieldbus connectors for retrofitting can be ordered from Endress+Hauser as a spare part → 77.

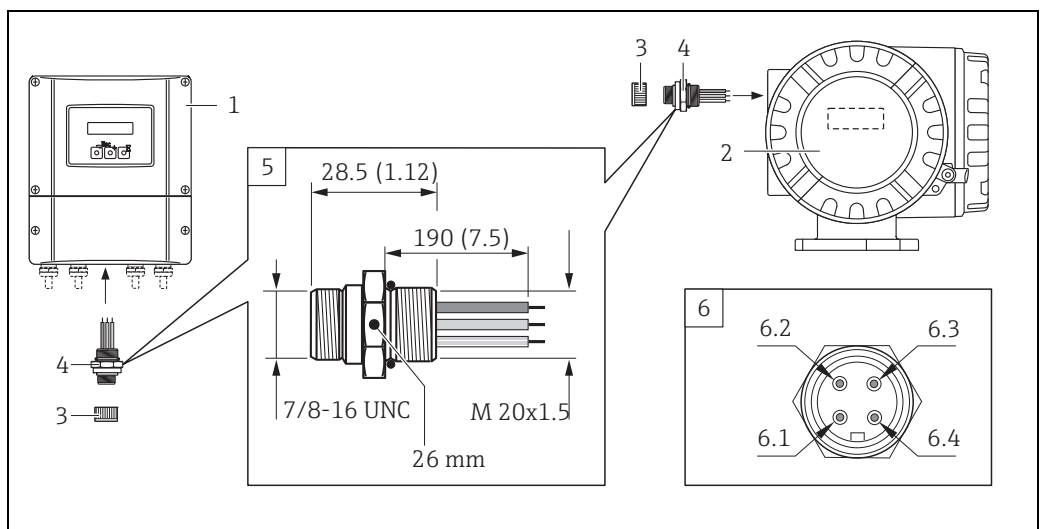

Fig. 32: Connector for connecting to the FOUNDATION Fieldbus

- 1 Wall-mount housing
- 2 Aluminum field housing
- 3 Protection cap for connector
- 4 Fieldbus connector
- 5 Dimensions Fieldbus connector
- 6 Field bus connector (pin assignment/color codes)
 - 6.1 Brown wire: FF + (Terminal 26)
 - 6.2 Blue wire: FF - (Terminal 27)
 - 6.3 Not assigned
 - 6.4 Green/yellow: ground (notes on connection → 44)

Technical data, connector:
 - Degree of protection IP 67
 - Ambient temperature: -40 to +150 °C (-40 to +302 °F)

4.4.3 Terminal assignment



Note!
 The electrical characteristic quantities are listed in the "Technical data" section.

Order code for "Input / Output"	Terminal No.			
	20 (+) / 21 (-)	22 (+) / 23 (-)	24 (+) / 25 (-)	26 = FF + ¹ 27 = FF - ¹
K	-	-	-	FOUNDATION Fieldbus

¹ With integrated reverse polarity protection

4.5 Potential equalization



Warning!

The potential equalization has to involved the measuring system.

Proper measurement is only ensured when the medium and the sensor have the same electrical potential. Most Promag sensors have a reference electrode installed as standard, which guarantees the required potential equalization.

The following must also be taken into account for potential equalization:

- Company-internal grounding guidelines
- Operating conditions such as material/grounding of piping etc. (see table)

4.5.1 Potential equalization, Promag S

- Reference electrode is standard for electrode material 1.4435 (316L), Alloy C-22, tantalum, titanium Gr. 2, Duplex 1.4462, tungsten carbide coating (for electrodes made of 1.4435)
- Reference electrode is optional for electrode made of platinum
- Reference electrode not present in measuring tubes with a natural rubber lining in conjunction with brush electrodes.



Caution!

- For sensors without reference electrodes or without metal process connections, carry out potential equalization as per the instructions for special cases → 46. These special measures are particularly important when standard grounding measures cannot be applied or extreme equalizing currents are expected.
- Sensors with brush electrodes do not have a reference electrode. For this reason, ground disks need to be installed in some cases to ensure sufficient potential equalization to the fluid. This applies in particular to isolating lined pipes which are not grounded → 46.

4.5.2 Potential equalization, Promag H

No reference electrode available!

The metallic process connection always establishes an electrical connection to the fluid.



Caution!

When using process connections made of plastic, potential equalization must be guaranteed through the use of grounding rings → 27.

The necessary grounding rings may be ordered separately as an accessory from Endress+Hauser (→ 77).

4.5.3 Connection examples for potential equalization

Standard case

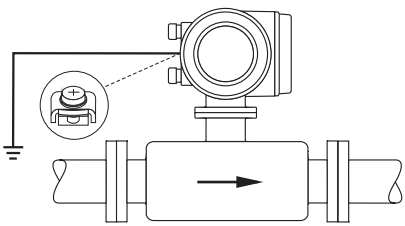
Operating conditions	Potential equalization
<p>When using the measuring device in:</p> <ul style="list-style-type: none"> ■ Metallic, grounded piping <p>Potential equalization is carried out via the ground terminal of the transmitter.</p> <p> Note! For installation in metal pipes, it is advisable to connect the ground terminal of the transmitter housing to the piping.</p>	 <p style="text-align: right; font-size: small;">A0011892</p> <p>Fig. 33: Via the transmitter's ground terminal</p>

Special cases

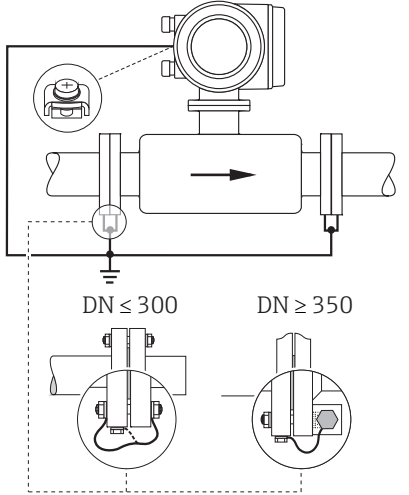
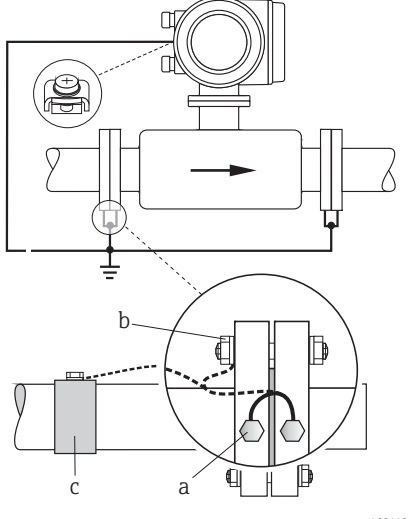
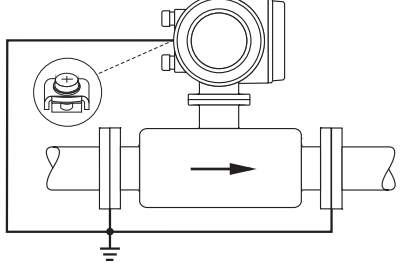
Operating conditions	Potential equalization
<p>When using the measuring device in:</p> <ul style="list-style-type: none"> ▪ Metallic, ungrounded piping <p>This type of connection occurs when:</p> <ul style="list-style-type: none"> ▪ The usual potential equalization cannot be guaranteed ▪ Extremely high equalizing currents are expected <p>A ground cable (copper wire, at least 6 mm² (0.0093 in²)) is used to connect both sensor flanges to the respective pipe flange and to ground them. Connect the transmitter or sensor connection housing, as applicable, to ground potential by means of the ground terminal provided for this purpose.</p> <p>The installation of the ground cable depends on the nominal diameter:</p> <ul style="list-style-type: none"> ▪ DN ≤ 300 (12"): The ground cable is in direct connection with the conductive flange coating and is secured by the flange screws. ▪ DN ≥ 350 (14"): The ground cable connects directly to the metal transport bracket. <p> Note! The ground cable for flange-to-flange connections can be ordered separately as an accessory from Endress+Hauser.</p>	 <p style="text-align: right;">A0011893</p> <p>Fig. 34: Via the transmitter's ground terminal and the pipe flanges</p>
<p>Version with pre-installed ground cable for DN ≤ 300 (12") (order option)</p> <p>Ground cables (copper wire, min. 6 mm² (0.0093 in²)), which are pre-installed on the sensor flange, are also optionally available. These ground cables can be secured and connected electrically to the piping in different ways:</p> <ul style="list-style-type: none"> ▪ Using a screw on the side of the pipe flange (a) ▪ Using the flange screws (b) ▪ Using a pipe clip installed around the pipe (c) 	 <p style="text-align: right;">A0011897</p> <p>Fig. 35: Possibilities for connecting and securing preinstalled ground cables</p>
<p>When using the measuring device in:</p> <ul style="list-style-type: none"> ▪ Plastic pipes ▪ Isolating lined pipes <p>This type of connection occurs when:</p> <ul style="list-style-type: none"> ▪ The usual potential equalization cannot be guaranteed ▪ Extremely high equalizing currents are expected <p>Potential equalization takes place using additional ground disks, which are connected to the ground terminal via a ground cable (copper wire, min. 6 mm² (0.0093 in²)). When installing the ground disks, please comply with the enclosed Installation Instructions.</p>	 <p style="text-align: right;">A0011895</p> <p>Fig. 36: Via the transmitter's ground terminal and the optionally available ground disks</p>

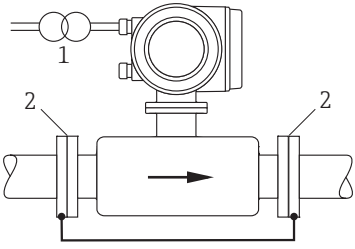
Operating conditions	Potential equalization
<p>When using the measuring device in:</p> <ul style="list-style-type: none"> ▪ Pipes with cathodic protection <p>The device is installed in the pipeline in such a way that it is potential-free.</p> <p>Using a ground cable (copper wire, min. 6 mm² (0.0093 in²)), only the two pipe flanges are connected. When doing so, the ground cable is mounted directly on the conductive flange coating using flange screws.</p> <p>Please note the following during installation:</p> <ul style="list-style-type: none"> ▪ The relevant regulations for potential-free installations must be observed. ▪ There must not be an electrically conductive connection between the piping and the device. ▪ The mounting material must be able to withstand the relevant torques. 	 <p style="text-align: right;">A0011896</p> <p>Fig. 37: Potential equalization and cathodic protection</p> <p>1 Isolation transformer power supply 2 Electrically isolated</p>

4.6 Degree of protection

The devices fulfill all the requirements for IP 67 (NEMA 4X).

Compliance with the following points is mandatory following installation in the field or servicing, in order to ensure that IP 67 protection (NEMA 4X) is maintained:

- The housing seals must be clean and undamaged when inserted into their grooves. The seals must be dried, cleaned or replaced if necessary.
- All housing screws and screw covers must be firmly tightened.
- The cables used for connection must be of the specified external diameter → 100.
- Tighten cable glands to prevent leakages.
- The cables must loop down before they enter the cable entries ("water trap"). This arrangement prevents moisture penetrating the entry. Always install the measuring device in such a way that the cable entries do not point up.
- Close off unused cable entries using suitable insert plugs.
- Do not remove the grommet from the cable entry.

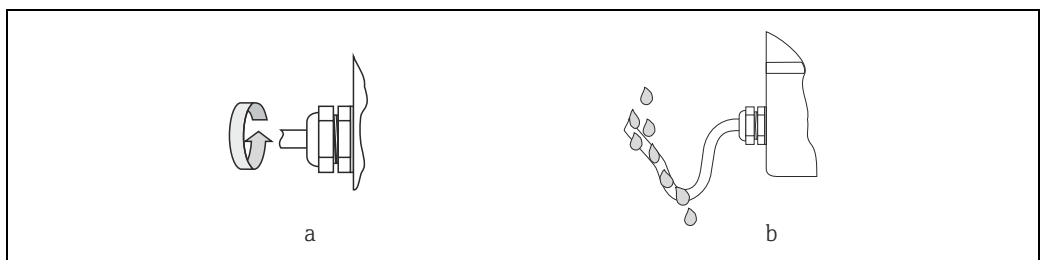

Fig. 38: Installation instructions, cable entries



Caution!

Do not loosen the screws of the sensor housing as otherwise the degree of protection guaranteed by Endress+Hauser no longer applies.



Note!

The sensor Promag S can also be supplied with IP 68 rating (permanent immersion in water to a depth of 3 meters). In this case the transmitter must be installed remote from the sensor.

4.7 Post-connection check

Perform the following checks after completing electrical installation of the measuring device:

Device condition and specifications	Notes
Are cables or the device damaged (visual inspection)?	-
Electrical connection	Notes
Does the supply voltage match the specifications on the nameplate?	→ 99
Do the cables comply with the specification?	FOUNDATION Fieldbus → 35 Sensor cable → 42
Do the cables have adequate strain relief?	-
Is the cable type route completely isolated? Without loops and crossovers?	-
Are the power-supply and electrode cables correctly connected?	See the wiring diagram inside the cover of the connection compartment
Only remote version: Is the flow sensor connected to the matching transmitter electronics?	Check serial number on nameplates of sensor and connected transmitter
Only remote version: Is the connecting cable between sensor and transmitter connected correctly?	→ 35
Are all screw terminals firmly tightened?	-
Have the measures for grounding/potential equalization been correctly implemented?	→ 46
Are all cable entries installed, firmly tightened and correctly sealed? Cables looped as "water traps"?	→ 48
Are all housing covers installed and firmly tightened?	-
Electrical connection of FOUNDATION Fieldbus H1	Notes
Are all the connecting components (T-boxes, junction boxes, connectors, etc.) correctly connected with each other?	-
Has each fieldbus segment been terminated at both ends with a bus terminator?	-
Has the max. length of the fieldbus cable been observed in accordance with the FOUNDATION Fieldbus specifications?	→ 36
Has the max. length of the spurs been observed in accordance with the FOUNDATION Fieldbus specifications?	→ 36
Is the fieldbus cable fully shielded (90%) and correctly grounded?	→ 37

5 Operation

5.1 Quick operation guide

The user has a number of options for configuring and commissioning the device:

1. **Local display (option)** → 51
The local display enables you to read all important variables directly at the measuring point, configure device-specific parameters in the field and perform commissioning.
2. **Operating programs** → 57
The FF functions and device-specific parameters are configured primarily via the fieldbus interface. Special configuration and operating programs from various manufacturers are available to users for this purpose.
3. **Jumpers for diverse hardware settings** → 59
Jumpers on the I/O board provide the means of setting the following hardware parameters for the FOUNDATION Fieldbus:
 - Enabling/disabling the simulation mode in the function blocks (e.g. AI, DO function block)
 - Switching the hardware write protection on and off

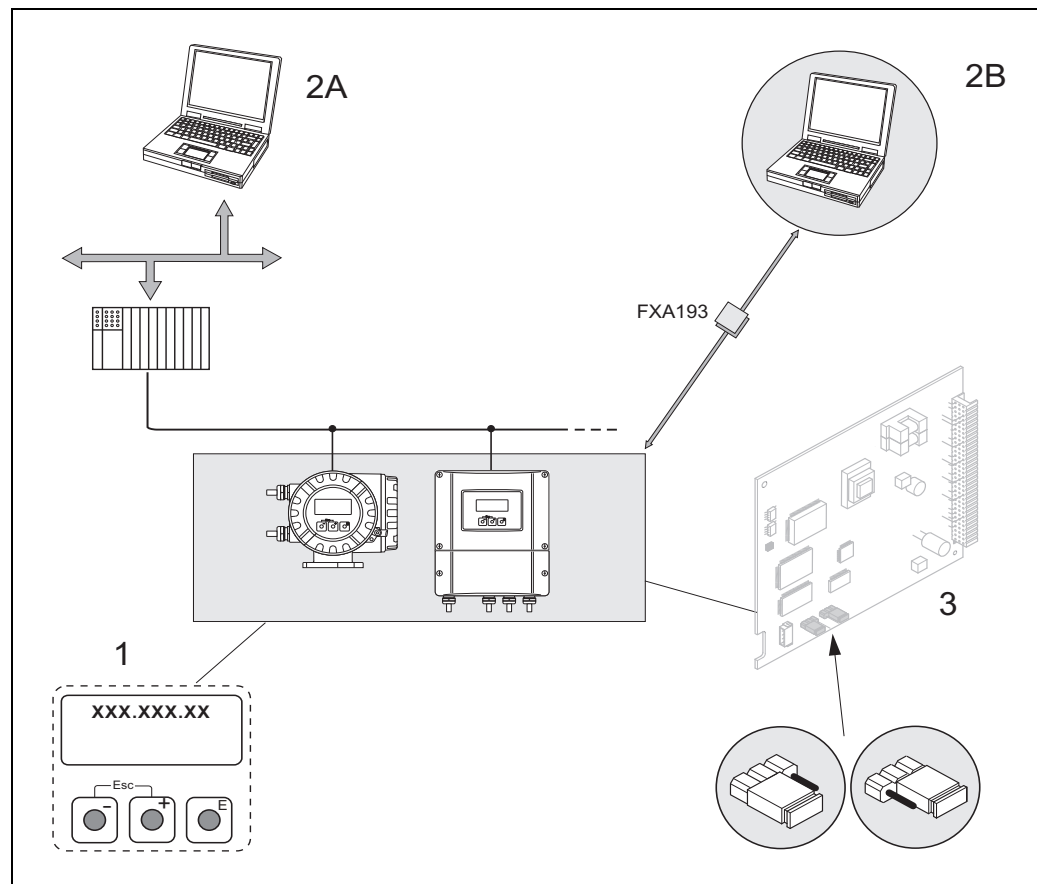

Fig. 39: FOUNDATION Fieldbus operating options

- 1 Local display for device operation in the field (option)
- 2A Configuration/operating programs for operating via the FOUNDATION Fieldbus (FF functions, device parameters)
- 2B Configuration/operating program for operating via the FXA193 service interface (e.g. FieldCare)
- 3 Jumper/miniature switches for hardware settings (write protection, simulation mode)

5.2 Local display

5.2.1 Display and operating elements

The local display enables you to read important parameters directly at the measuring point or to configure your device using the "Quick Setup" or the function matrix.

The display consists of four lines; this is where measured values and/or status variables (direction of flow, empty pipe, bar graph, etc.) are displayed. You can change the assignment of display lines to variables at will in order to customize the display to suit your needs and preferences (→ see the "Description of Device Functions" manual).

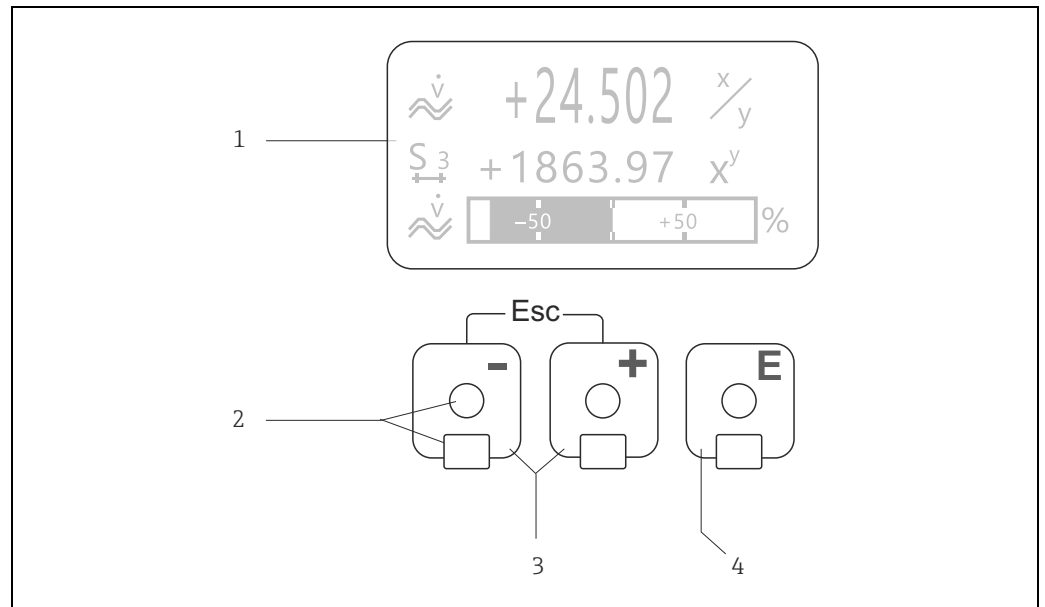

Fig. 40: Display and operating elements

- 1 **Liquid crystal display**
The backlit, four-line liquid crystal display shows measured values, dialog texts, fault messages and notice messages. The display as it appears when normal measuring is in progress is known as the HOME position (operating mode).
Display
- 2 **Optical sensors for Touch Control**
- 3 **⏏/⏏ keys**
 - HOME position → Direct access to totalizer values and actual values of inputs/outputs
 - Enter numerical values, select parameters
 - Select different blocks, groups and function groups within the function matrix

Press the ⏏/⏏ keys **simultaneously** to trigger the following functions:

 - Exit the function matrix step by step → HOME position
 - Press and hold down the ⏏/⏏ keys for longer than 3 seconds → Return directly to the HOME position
 - Cancel data entry
- 4 **⏏ key (Enter key)**
 - HOME position → Entry into the function matrix
 - Save the numerical values you input or settings you change

5.2.2 Display (operating mode)

The display area consists of three lines in all; this is where measured values are displayed, and/or status variables (direction of flow, bar graph, etc.). You can change the assignment of display lines to variables at will in order to customize the display to suit your needs and preferences (→ see the "Description of Device Functions" manual).

Multiplex mode:

A maximum of two different display variables can be assigned to each line. Variables multiplexed in this way alternate every 10 seconds on the display.

Error messages:

Display and presentation of system/process errors →  56

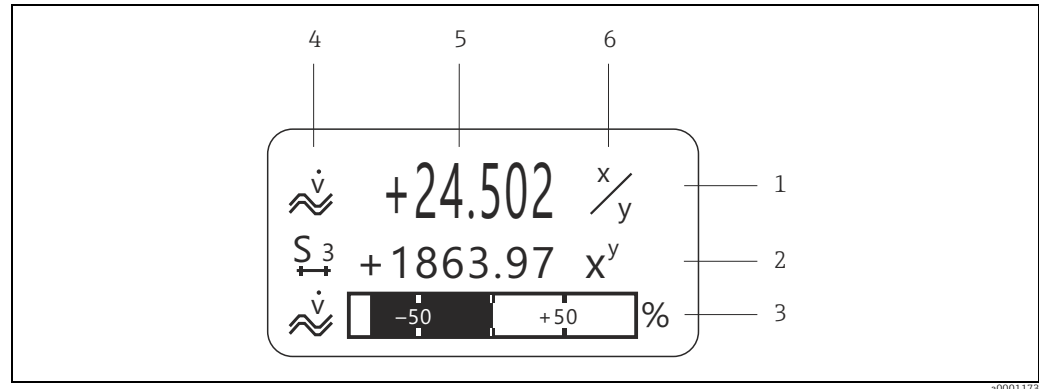





Fig. 41: Typical display for normal operating mode (HOME position)

- 1 Main line shows main measured values, e.g. flow
- 2 Supplementary line shows supplementary measured or status variables, e.g. totalizer reading.
- 3 Information line shows additional information on measured or status variables, e.g. bar graph representation of the full scale value attained by the flow rate
- 4 "Info icons" field shows additional information in the form of icons on the measured values displayed. A complete overview of all icons and their meaning can be found on →  53
- 5 "Measured values" field shows the current measured values
- 6 "Engineering unit" field shows the engineering units and time units defined for the current measured values.



Note!

In the HOME position, you can use the   keys to call up a list containing the following information:







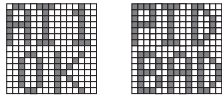

- Totalizer values (including overflow)
- Tag name (DEVICE PD-TAG)

  key → queries individual values in the list

Simultaneously press Esc key () → Return to the HOME position

5.2.3 Icons

The icons which appear in the field on the left make it easier to read and recognize measured variables, device status, and error messages.

Icon	Meaning	Icon	Meaning
S	System error	P	Process error
	Fault message (with impact on outputs)	!	Notice message (without impact on outputs)
Σ 1...n	Totalizer 1...n	AI (1...n)	Analog Input function block (1...n), output value OUT
PID	PID function block: A PID function block value as listed below is output, depending on the assignment of the lines in the local display: - OUT value (= manipulated variable) - IN value (= control variable) - CAS_IN value (= external set point)		
The messages listed below describe the status of the OUT value of the Analog Input function block and the value assigned to the PID function block.			
OK	Status = GOOD (valid)	UNC	Status = UNCERTAIN (conditionally valid)
BAD	Status = BAD (invalid)	Example:  <small>a0006255</small>	
 <small>a0001182</small>	Measuring mode: SYMMETRY (bidirectional)	 <small>a0001183</small>	Measuring mode: STANDARD
 <small>a0001184</small>	Totalizer counting mode: BALANCE (forward and reverse flow)	 <small>a0001185</small>	Totalizer counting mode: forward
 <small>a0001186</small>	Totalizer counting mode: reverse		
 <small>a0001188</small>	Volume flow	 <small>a0001195</small>	Mass flow

5.3 Brief Operating Instructions for the function matrix



Note!

- See the general notes → 55
 - Function descriptions → See the "Description of Device Functions" manual
1. HOME position → **it** → Enter the function matrix
 2. **+**/**-** → Select a block (e.g. MEASURED VARIABLES) → **E**
 3. **+**/**-** → Select a group (e.g. SYSTEM UNITS) → **E**
 4. **+**/**-** → Select a function group (e.g. CONFIGURATION) → **E**
 5. Select a function (e.g. UNIT VOLUME FLOW) and change parameters/enter numerical values:
 - +**/**-** → Select or enter release code, parameters, numerical values
 - E** → Save entries
 6. Exit the function matrix:
 - Press and hold down Esc key (**Esc**) for longer than 3 seconds → HOME position
 - Repeatedly press Esc key (**Esc**) → Return step by step to HOME position

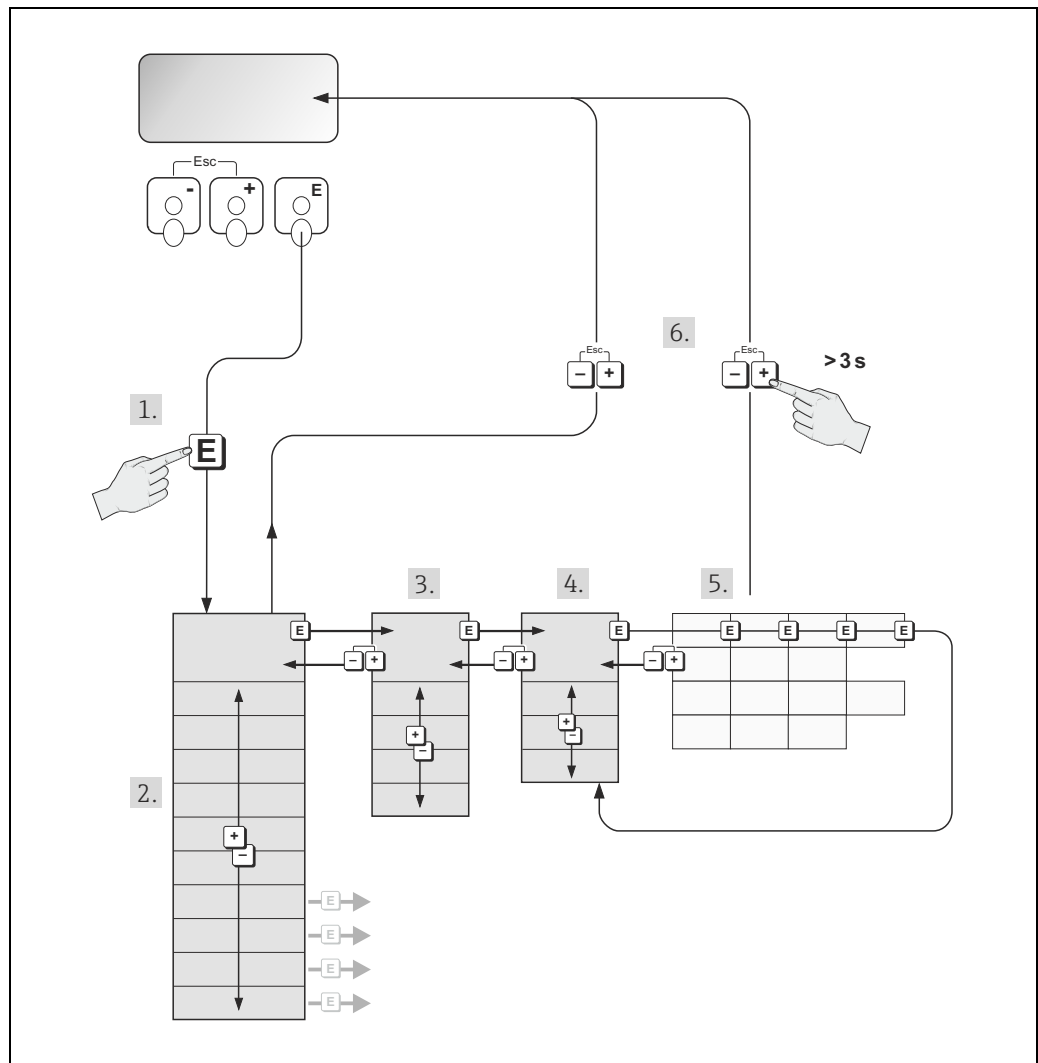



Fig. 42: Selecting functions and configuring parameters (function matrix)

5.3.1 General notes

The Quick Setup menu is adequate for commissioning with the necessary standard settings. Complex measuring operations on the other hand necessitate additional functions that you can configure as necessary and customize to suit your process parameters. The function matrix, therefore, comprises a multiplicity of additional functions which, for the sake of clarity, are arranged on a number of menu levels (blocks, groups, and function groups).

Comply with the following instructions when configuring functions:

- You select functions as described →  54.
Each cell in the function matrix is identified by a numerical or letter code on the display.
- You can switch off certain functions (OFF). If you do so, related functions in other function groups will no longer be displayed.
- Certain functions prompt you to confirm your data entries. Press O/S to select "SURE | YES |" and press F again to confirm. This saves your setting or starts a function, as applicable.
- Return to the HOME position is automatic if no key is pressed for 5 minutes.
- Programming mode is automatically disabled if you do not press a key within 60 seconds following automatic return to the HOME position.



Caution!

All functions are described in detail, including the function matrix itself, in the "Description of Device Functions" manual, which is a separate part of these Operating Instructions.



Note!



- The transmitter continues to measure while data entry is in progress, i.e. the current measured values are output via the signal outputs in the normal way.
- If the power supply fails, all preset and parameterized values remain safely stored in the EEPROM.

5.3.2 Enabling the programming mode

The function matrix can be disabled. Disabling the function matrix rules out the possibility of inadvertent changes to device functions, numerical values or factory settings. A numerical code (factory setting = 55) has to be entered before settings can be changed.

If you use a code number of your choice, you exclude the possibility of unauthorized persons accessing data (→ "Description of Device Functions" manual).

Comply with the following instructions when entering codes:

- If programming is disabled and the / keys are pressed in any function, a prompt for the code automatically appears on the display.
- If "0" is entered as the customer's code, programming is always enabled.
- The Endress+Hauser service organization can be of assistance if you mislay your personal code.



Caution!

- Changing certain parameters such as all sensor characteristics, for example, influences numerous functions of the entire measuring system, particularly measuring accuracy. There is no need to change these parameters under normal circumstances and consequently, they are protected by a special code known only to the Endress+Hauser service organization. Please contact Endress+Hauser first if you have any questions.
- With FF, programming is enabled separately in the Transducer Blocks.

5.3.3 Disabling the programming mode

Programming mode is disabled if you do not press a key within 60 seconds following automatic return to the HOME position.

You can also disable programming in the ACCESS CODE function by entering any number (other than the customer's code).

5.4 Error messages

5.4.1 Type of error

Errors which occur during commissioning or measuring operation are displayed immediately. If two or more system or process errors occur, the error with the highest priority is the one shown on the display.

The measuring system distinguishes between two types of error:

- **System errors:** This group comprises all device errors, e.g. communication errors, hardware errors, etc. → 84.
- **Process error:** This group includes all application errors e.g. empty pipe, etc. → 88.

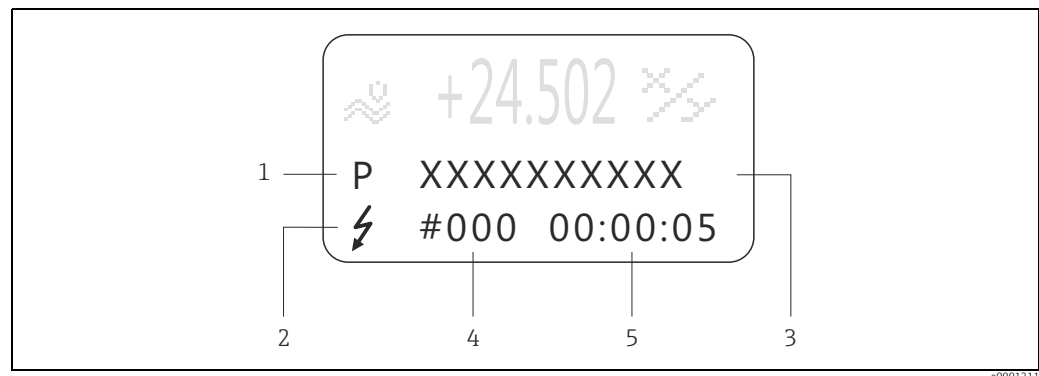

Fig. 4.3: Error messages on the display (example)

- 1 Error type: P = process error, S = system error
- 2 Error message type: ⚡ = fault message, ! = notice message
- 3 Error designation
- 4 Error number
- 5 Duration of most recent error occurrence (hours : minutes : seconds)

5.4.2 Error message type

The device always assigns system and process errors to two error message types (**fault or notice message**), with the result that they are evaluated differently → 79.

Critical system errors, e.g. module defects, are always identified and displayed as "fault messages" by the measuring device.

Notice message (!)

- The error in question has no effect on the current operation.
- Displayed as → exclamation mark (!), error type (S: system error, P: process error)
- FOUNDATION Fieldbus → Notice messages are transmitted to downstream function blocks or higher-level process control systems using the "UNCERTAIN" status of the output value OUT (AI Block).

Fault message (⚡)

- The error in question interrupts or stops the current operation.
- Displayed as → lightning flash (⚡), error type (S: system error, P: process error)
- FOUNDATION Fieldbus → Fault messages are transmitted to downstream function blocks or higher-level process control systems using the "BAD" status of the output value OUT (AI Block).

5.5 Operating programs

5.5.1 "FieldCare" operating program

FieldCare is Endress+Hauser's FDT-based plant asset management tool and enables the configuration and diagnosis of intelligent field devices. Through the use of status information, you also avail of a simple but effective tool for monitoring devices. The Proline flowmeters are accessed via a service interface e.g. service interface FXA193.

5.5.2 Operating with the FOUNDATION Fieldbus configuration programs

The user can obtain special configuration and operating programs offered by the different manufacturers for use in configuration. These can be used for configuring both the FOUNDATION Fieldbus functions and all the device-specific parameters. The predefined function blocks allow uniform access to all the network and fieldbus device data.

A step-by-step description of the procedure for commissioning the FOUNDATION Fieldbus functions is given on →  61, along with the configuration of device-specific parameters. General information on FOUNDATION Fieldbus is provided in the Operating Instructions "FOUNDATION Fieldbus Overview" (BA013S) available at: → www.endress.com → Download.

System files

You will need the following files for commissioning and network configuration:

- Commissioning → Device description (Device Description: *.sym, *.ffo)
- Network configuration → CFF file (Common File Format: *.cff)

You can obtain these files as follows:

- Free of charge from the internet → www.endress.com
- From Endress+Hauser stating the order number (No. 56003896)
- Via the Fieldbus Foundation Organization → www.fieldbus.org



Note!

Ensure you use the correct system files for linking the field devices into the host system. Appropriate version information can be called up via the following functions/parameters:

Local display:

- HOME → BASIC FUNCTION → FOUND. FIELDBUS → INFORMATION → DEVICE REVISION (6243)
- HOME → BASIC FUNCTION → FOUND. FIELDBUS → INFORMATION → DD REVISION (6244)

FOUNDATION Fieldbus configuration program:

- Resource Block → Parameter DEV_REV
- Resource Block → Parameter DD_REV

Example (with local display):

Displayed in the DEVICE REVISION (6243) function → 04

Displayed in the DD REVISION (6244) function → 01

Device description file (DD) required → 0401.sym / 0401.ffo

5.5.3 Current device description files

The following table illustrates the suitable device description file for the operating tool in question and then indicates where these can be obtained.

FOUNDATION Fieldbus protocol:

Valid for software	4.00.XX	→ "Device software" function (8100)
FOUNDATION Fieldbus device data		
Manufacturer ID:	11 _{hex} (ENDRESS+HAUSER)	→ "Manufact ID" function (6040)
Device ID:	1042 _{hex}	→ "Device ID" function (6041)
FOUNDATION Fieldbus version data	Device Revision 4/DD Revision 1	
Software release	11.2014	
Operating program:	Sources for obtaining device descriptions/program updates::	
Device Description (DD) and Capability File (CFF)	<ul style="list-style-type: none"> ▪ www.endress.com (→ Download → Software → Driver) ▪ CD-ROM (Endress+Hauser order number: 56003896) ▪ www.fieldbus.org 	
Device driver for the FF host systems::	Sources for obtaining:	
ABB (FieldController 800)	www.abb.com	
Allen Bradley (Control Logix)	See FF standard device driver	
Emerson (Delta V)	www.easydeltav.com	
Endress+Hauser (ControlCare)	See FF standard device driver	
Honeywell (Experion PKS)	www.honeywell.com	
SMAR (System 302)	See FF standard device driver	
Yokogawa (CENTUM CS 3000)	www.yokogawa.com	
Device driver for further FOUNDATION Fieldbus operating tools:	Sources for obtaining updates:	
Handheld terminal DXR375	<ul style="list-style-type: none"> ▪ www.fieldcommunicator.com <p> Note! The device drivers can be added and updated via the 375 Field Communicator easy upgrade program utility.</p>	

Operation via the service protocol:

Tester/simulator::	Sources for obtaining updates:
Fieldcheck	<ul style="list-style-type: none"> ▪ Update via FieldCare using the Flow Device FXA193/291 DTM in the Fieldflash module

5.6 FOUNDATION Fieldbus hardware settings

5.6.1 Switching hardware write protection on and off

Two jumpers on the I/O board provide the means of activating or deactivating hardware write protection and simulation mode (for AI and DO function block).



Warning!

Risk of electric shock. Exposed components carry dangerous voltages. Make sure that the power supply is switched off before you remove the cover of the electronics compartment.

1. Switch off power supply.
2. Remove the I/O board → 91.
3. Configure the hardware write protection and simulation mode accordingly with the aid of the jumpers (see Figure).
4. Installation of the I/O board is the reverse of the removal procedure.

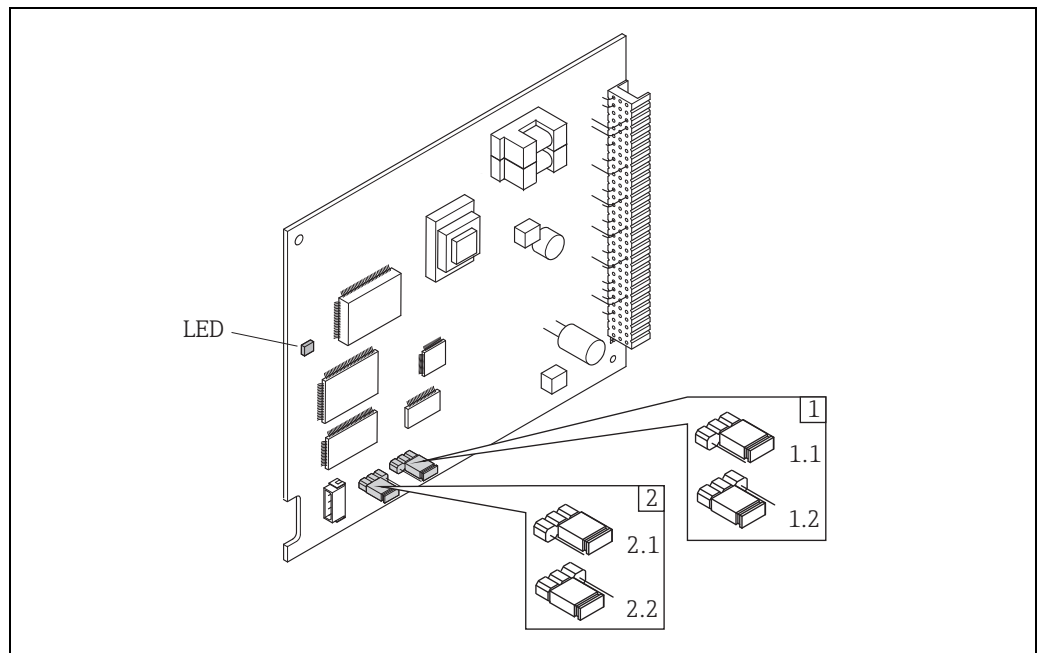



Fig. 44: Hardware configuration (I/O board)

- 1 Jumper for switching on/off the write protection:
- 1.1 Write protection switched off (default value) = write access to device functions via FF interface is possible
 - 1.2 Write protection switched on (default value) = write access to device functions via FF interface is **not** possible
- 2 Jumper for simulation mode:
- 2.1 Simulation mode enabled (default value) = simulation in Analog Input function block or in Discrete Output function block is possible
 - 2.2 Simulation mode disabled = simulation in Analog Input function block or in Discrete Output function block is **not** possible
- LED LED:
- Continuously lit → Ready (no communication via FF active)
 - Not lit → Not ready for operation
 - Flashes slowly → Ready (communication via FF active)
 - Flashes quickly → Device failure present (error message type "fault message") → 79

6 Commissioning

6.1 Function check

Make sure that all final checks have been completed before you start up your measuring point:

- Checklist for "Post-installation check" →  34
- Checklist for "Post-connection check" →  49

6.2 Switching on the measuring device

Once the connection checks have been successfully completed, it is time to switch on the power supply. The device is now operational.

The measuring device performs a number of post switch-on self-tests. As this procedure progresses the following sequence of messages appears on the local display:

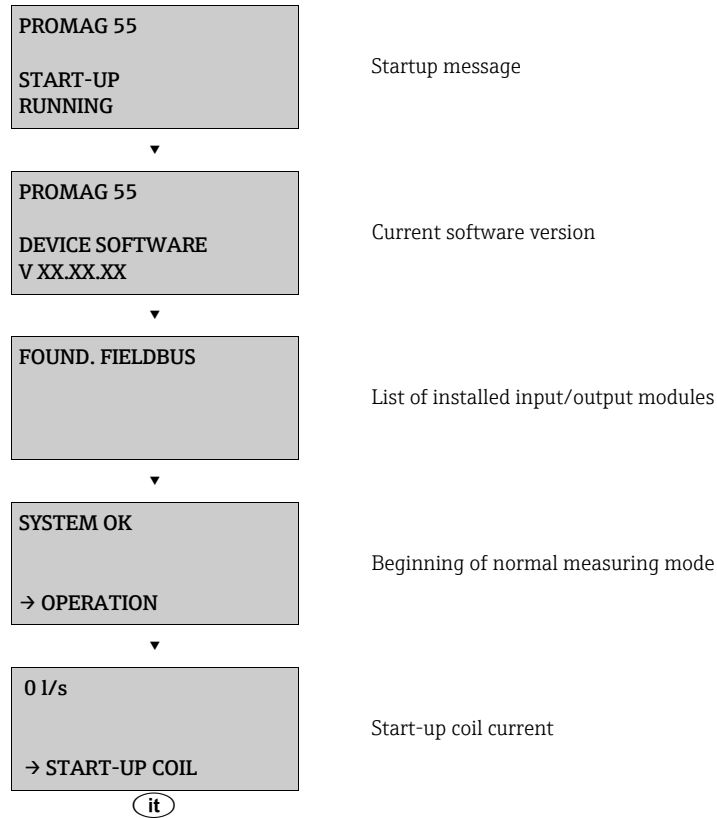

Normal measuring mode commences as soon as startup completes.

Various measured value and/or status variables appear on the display (HOME position).



Note!

If startup fails, an error message indicating the cause is displayed.

6.3 Commissioning using FOUNDATION Fieldbus

Note the following points:



- The files required for commissioning and network configuration can be obtained as described on →  57.
- The device is identified by the FOUNDATION Fieldbus in the host or configuration system via the device ID (DEVICE_ID). The DEVICE_ID is a combination of the manufacturer ID, device type and device serial number. It is unique and can never be duplicated. The DEVICE_ID of Promag 55 is composed as follows:

```

DEVICE_ID = 452B481042-XXXXXXXXXX
452B48 = Endress+Hauser
1042 = Promag 55
XXXXXXXXXX = device serial number (11-digit)
    
```

6.3.1 Commissioning

The following description allows step-by-step commissioning of the measuring device and all the necessary configuration for the FOUNDATION Fieldbus:

1. Switch on the measuring device.
2. Note the DEVICE_ID on the device nameplate →  6.
3. Open the configuration program.
4. Load the device description file or CFF file into the host system or into the configuration program. Ensure you use the correct system files. Refer to the example on →  57. The first time it is connected Promag 55 reports as follows:

- E+H_PROMAG_55_XXXXXXXXXX (tag name PD-TAG)
- 452B481042-XXXXXXXXXX (Device_ID)
- Block structure:

Display text (xxx... = serial number)	Base index	Description
RESOURCE_XXXXXXXXXX	400	Resource Block
TRANSDUCER_FLOW_XXXXXXXXXX	1400	"Flow" Transducer Block
TRANSDUCER_DIAG_XXXXXXXXXX	1600	"Diagnosis" Transducer Block
TRANSDUCER_DISP_XXXXXXXXXX	1800	"Display" Transducer Block
TRANSDUCER_TOT_XXXXXXXXXX	1900	"Totalizer" Transducer Block
TRANSDUCER_SCON_XXXXXXXXXX	2400	"Solids Content Flow" Transducer Block
TRANSDUCER_ADVD_XXXXXXXXXX	2500	"Advanced Diagnostics" Transducer Block
ANALOG_INPUT_1_XXXXXXXXXX	500	Analog Input function block 1
ANALOG_INPUT_2_XXXXXXXXXX	550	Analog Input function block 2
ANALOG_INPUT_3_XXXXXXXXXX	600	Analog Input function block 3
ANALOG_INPUT_4_XXXXXXXXXX	650	Analog Input function block 4
ANALOG_INPUT_5_XXXXXXXXXX	700	Analog Input function block 5
ANALOG_OUTPUT_XXXXXXXXXX	2300	Analog Output function block (AO)
DISCRETE_OUTPUT_XXXXXXXXXX	900	Discrete Output function block (DO)
PID_XXXXXXXXXX	1000	PID function block (PID)
ARITHMETIC_XXXXXXXXXX	1100	Arithmetic function block (ARTH)
INPUT_SELECTOR_XXXXXXXXXX	1150	Input Selector function block (ISEL)
SIGNAL_CHARACTER_XXXXXXXXXX	1200	Signal Characterizer function block (CHAR)
INTEGRATOR_XXXXXXXXXX	1250	Integrator function block (INTG)

**Note!**

The Promag 55 is supplied with the bus address "250" and is thus in the address range reserved for readdressing field devices, from 248 and 251. This means that the LAS (Link Active Scheduler) automatically assigns the device a free bus address in the initialization phase.

5. Identify the field device using the DEVICE_ID that you noted down and assign the desired field device tag name (PD_TAG) to the fieldbus device in question.
Factory setting: EH_PROMAG_55_XXXXXXXXXX

Configuration of the "Resource Block" (base index 400)

6. Open the Resource Block.
7. On delivery write protection is disabled so that you can access the write parameters via FF. Check this status via the parameter WRITE_LOCK:
 - Write protection activated = LOCKED
 - Write protection deactivated = NOT LOCKED

Deactivate the write protection if necessary → 59.

8. Enter the desired block name (optional).
Factory setting: RESOURCE_XXXXXXXXXX
9. Set the operating mode in the MODE_BLK parameter group (TARGET parameter) to AUTO.

Configuration of the "Transducer Blocks"

The individual Transducer Blocks comprise various parameter groups ordered by device-specific functions:

Transducer Block	Base index	Description
"Flow" Transducer Block	1400	Flow measurement
"Diagnosis" Transducer Block	1600	Diagnostic functions
"Display" Transducer Block	1800	Local display functions
"Totalizer" Transducer Block	1900	Totalizer 1 to 3
"Solids Content Flow" Transducer Block	2400	Solids content flow measurement
"Advanced Diagnostics" Transducer Block	2500	Extended diagnostic functions

The following description provides an example for the "Flow" Transducer Block (base index: 1400).

10. Enter the desired block name (optional).
Factory setting: TRANSDUCER_FLOW_XXXXXXXXXX
11. Open the "Flow" Transducer Block.
12. Now configure the device-specific parameters relevant for your application.

**Note!**

- Changes to the device parameters can only be made after entering a valid access code in the "Access - Code" parameter.
- The selection of the system units in the "Flow" Transducer Block has no effect on the output value OUT (AI Block). Units of the process variables which are transmitted via the FF interface must be specified separately in the Analog Input function block via the XD_SCALE and OUT_SCALE parameter group.

13. Set the "Flow" and "Totalizer" Transducer Blocks to AUTO in the MODE_BLK parameter group (TARGET parameter). Only then is it ensured that the process variables can be processed correctly by the downstream AI function block.

Configuration of the "Analog Input function blocks"

The measuring device has five Analog Input function blocks that can be assigned to the various process variables. The following description provides an example for the Analog Input function block 1 (base index: 500).

14. Enter the desired name for the Analog Input function block (optional).
Factory setting: ANALOG_INPUT_1xxxxxxxxxxx
15. Open the Analog Input function block 1.
16. Set the operating mode in the MODE_BLK parameter group (TARGET parameter) to OOS, i.e. block Out Of Service.
17. Using the CHANNEL parameter select the process variable that is to be used as the input value for the function block algorithm (scaling and limit value monitoring functions).
The following settings are possible:

Process variable	Channel parameter
Calculated mass flow	1
Volume flow	2
Totalizer 1	7
Totalizer 2	8
Totalizer 3	9
Conductivity	10
The following process variables are available if the add-on software "Solids content flow" is installed on the device (order option)	
Target mass flow	40
% Target mass	41
Target volume flow	42
% Target volume	43
Carrier mass flow	45
% Carrier mass flow	46
Carrier volume flow	47
% Carrier volume flow	48
The following process variables are available if the add-on software "Advanced Diagnostics" is installed on the device (order option).	
Deviation coating electrode 1	120
Deviation coating electrode 2	121
Deviation electrode potential 1	122
Deviation electrode potential 2	123
Deviation volume flow	124
Deviation noise value	125

18. In the XD_SCALE parameter group, select the desired engineering unit and the block input range (e.g. measurement range of the flow application) for the process variable in question (see the example below).

 **Caution!**

Make sure that the selected unit is suitable for the measurement variable of the selected process variable. Otherwise, the BLOCK_ERROR parameter will display the error message "Block Configuration Error", and the block operating mode cannot be set to AUTO.

19. In the L_TYPE parameter, select the mode of linearization for the input variable (Direct, Indirect, Indirect Sq Root) → "Description of Device Functions" manual



Caution!

Note that with the type of linearization "Direct" the configuration of the OUT_SCALE parameter group must agree with the configuration of the XD_SCALE parameter group. Otherwise the block operating mode cannot be set to AUTO. Such incorrect configuration is indicated in the BLOCK_ERROR parameter via the "Block Configuration Error" message.

Example:

- The measurement range of the sensor is 0 to 30 m³/h.
- The output range to the automation system should be 0 to 30 m³/h also.

The following settings should be made:

- Analog Input function block/ CHANNEL parameter (selection of input value), selection: 2 → Volume flow
- L_TYPE parameter → Direct
- XD_SCALE parameter group
 - XD_SCALE 0% = 0
 - XD_SCALE 100% = 30
 - XD_SCALE UNIT = m³/h
- OUT_SCALE parameter group
 - OUT_SCALE 0% = 0
 - OUT_SCALE 100% = 30
 - OUT_SCALE UNIT = m³/h

20. Use the following parameters to define the limit values for alarm and warning messages:

- HI_HI_LIM → Limit value for the upper alarm
- HI_LIM → Limit value for the upper warning
- LO_LIM → Limit value for the lower warning
- LO_LO_LIM → Limit value for the lower alarm

The limit values entered must be within the value range specified in the OUT_SCALE parameter group.

21. In addition to the actual limit values you must also specify the action taken if a limit value is exceeded using so-called "alarm priorities" (parameters HI_HI_PRI, HI_PRI, LO_PR, LO_LO_PRI) → See the "Description of Device Functions" manual. Reporting to the fieldbus host system only takes place if the alarm priority is higher than 2.
22. System configuration/connection of function blocks:
A concluding "overall system configuration" is essential so that the operating mode of the Analog Input function block can be set to AUTO and so that the field device is integrated into the system application. To do this, configuration software such as the NI-FBUS Configurator from National Instruments is used to connect the function blocks to the desired control strategy - generally graphically - and then the sequence of the individual process control functions is specified.
23. After specifying the active LAS, download all the data and parameters into the field device.
24. Set the operating mode in the MODE_BLK parameter group (TARGET parameter) to AUTO. However, this is possible only under two conditions:
- The function blocks are correctly connected with each other.
 - The Resource Block is in operating mode AUTO.

Configuration of the "Analog Output function block" (base index 2300)

The measuring device has an Analog Output function block that can be assigned to the various process variables.



Note!

The process value transmitted to the Analog Output function block by the density measuring device must be greater than 0, in order to avoid the status BAD or UNCERTAIN.

The following example shows how the value of a density measuring device (e.g. Gammapiot M) for operating density ("System Value - Fixed Density" parameter, → 69) can be read in via the Analog Output function block.

Firstly, a connection must be established between the Analog Output function block and the "System Value - Fixed Density" parameter in the "Flow" Transducer Block. In addition, the value "4" (density) must be assigned to the CHANNEL parameter.

25. Enter the desired name for the Analog Output function block (optional). Factory setting: ANALOG_OUTPUT_XXXXXXXXXX
26. Open the Analog Output function block.
27. Set the operating mode in the MODE_BLK parameter group (TARGET parameter) to OOS, i.e. block Out Of Service.
28. Using the CHANNEL parameter, select "Density" which is to be used as the input value for the Transducer Block algorithm (scaling function).
The following settings are possible:

Process variable	Channel parameter
Density	4

29. In the PV_SCALE parameter group, select the desired engineering unit and the block input range (measuring range of the density application) for the relevant process variable (see the following example).



Caution!

Make sure that the selected unit is suitable for the measurement variable of the selected process variable. Otherwise, the BLOCK_ERROR parameter will display the error message "Block Configuration Error", and the block operating mode cannot be set to AUTO.

Example:

- The measuring range of the density application is 0 to 30 kg/l.
- The output range to the automation system should be 0 to 30 kg/l also.
- The following settings are required:
 - Analog Output function block / CHANNEL parameter (output value option), option 4 = density
 - SHED_OPTIONS parameter → e.g. Normal Shed Normal Return
 - PV_SCALE parameter group
 - PV_SCALE 0% = 0
 - PV_SCALE 100% = 30
 - PV_SCALE UNIT = kg/l
 - OUT_SCALE parameter group
 - OUT_SCALE 0% = 0
 - OUT_SCALE 100% = 30
 - OUT_SCALE UNIT = kg/l

30. Set the operating mode in the MODE_BLK parameter group (TARGET parameter) to AUTO.

31. System configuration/connection of function blocks:

A concluding "overall system configuration" is essential so that the operating mode of the Analog Output function block can be set to AUTO and so that the device is integrated into the system application. To do this, configuration software is used to connect the function blocks to the desired control strategy - mainly graphically - and the sequence of the individual process control functions is then specified.

6.3.2 "Commissioning" Quick Setup menu

If the measuring device is equipped with a local display, all device-specific parameters that are important for standard measuring operation can be configured easily and quickly using the "Commissioning" Quick Setup menu.

In the case of measuring devices without a local display, the individual parameters and functions must be configured via the configuration program, e.g. NI-FBUS Configurator.

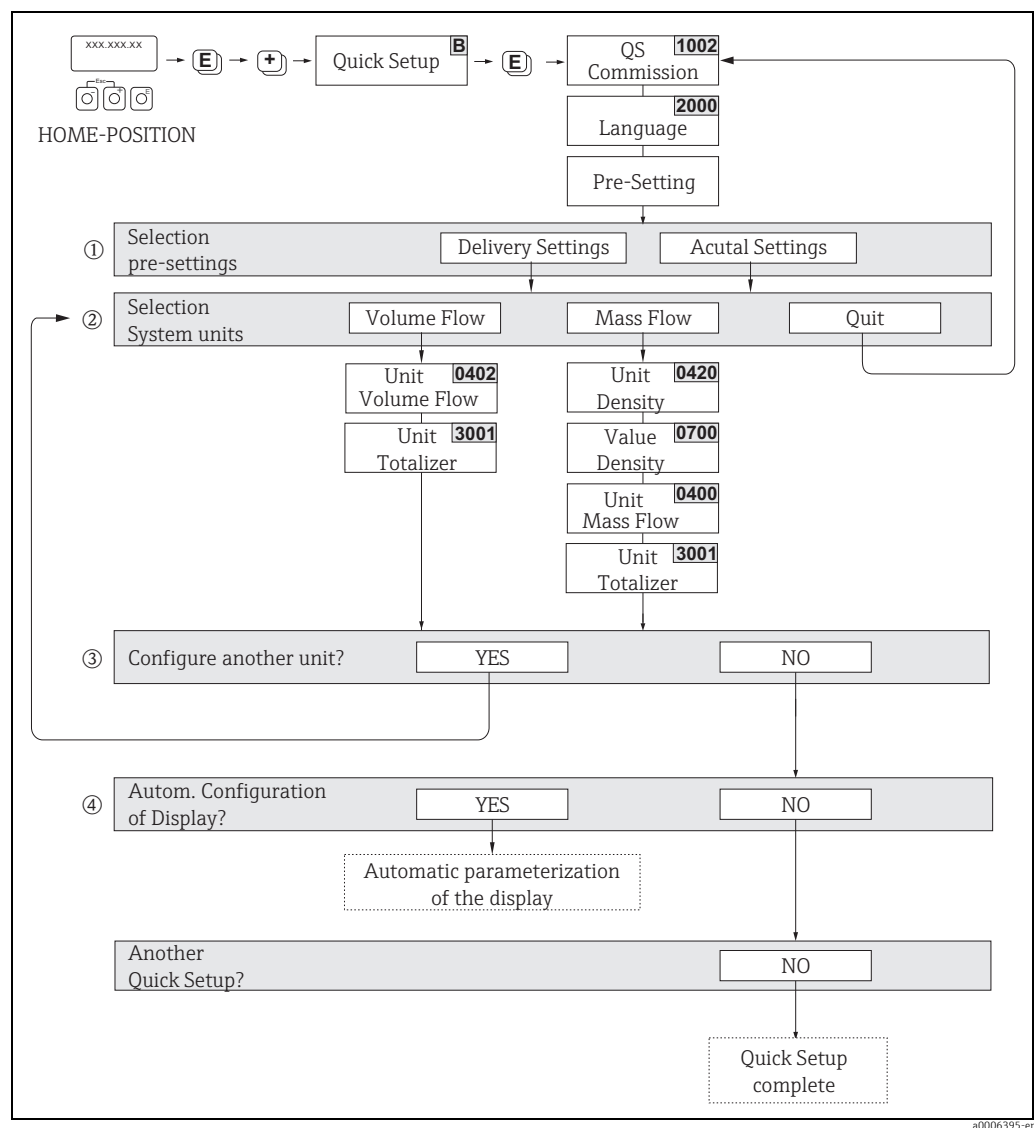



Fig. 45: Quick Setup for straightforward commissioning

- ① The DELIVERY SETTINGS option sets each selected unit to the factory setting. The ACT.SETTING option accepts the units previously set by you.
- ② Only units not yet configured in the current setup are offered for selection in each cycle. The unit for Mass and Volume is derived from the corresponding flow unit.

- ③ The "YES" option remains visible until all the units have been configured. "NO" is the only option displayed when no further units are available.
- ④ The "automatic parameterization of the display" option contains the following basic settings/factory settings:
 - YES Main line = Volume flow
 Additional line = Totalizer 1
 Information line = Operating/System conditions
 - NO The existing (selected) settings remain.

**Note!**

- The display returns to the SETUP COMMISSIONING (1002) cell if you press the  key combination during parameter interrogation. The stored parameters remain valid.
- The system units selected via the Quick Setup are only valid for the local display and for parameters in the Transducer Blocks. They do not affect the process variables which are transmitted via FOUNDATION Fieldbus.

6.3.3 Data backup/transmission

Using the T-DAT SAVE/LOAD function, you can transfer data (device parameters and settings) between the T-DAT (exchangeable memory) and the EEPROM (device storage unit).

This is required in the following instances:

- Creating a backup: current data are transferred from an EEPROM to the T-DAT.
- Replacing a transmitter: current data are copied from an EEPROM to the T-DAT and then transferred to the EEPROM of the new transmitter.
- Duplicating data: current data are copied from an EEPROM to the T-DAT and then transferred to EEPROMs of identical measuring points.



Note!

For information on installing and removing the T-DAT → 90.

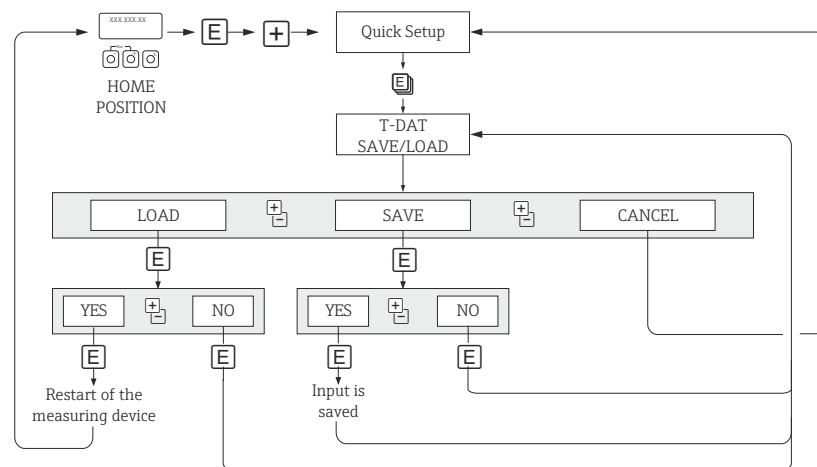

a0001221-en

Fig. 46: Data backup/transmission with T-DAT SAVE/LOAD function

Information on the LOAD and SAVE options available:

LOAD: Data are transferred from the T-DAT to the EEPROM.



Note!

- Any settings already saved on the EEPROM are deleted.
- This option is only available if the T-DAT contains valid data.
- This option can be performed only if the T-DAT is using either the same software version as the EEPROM or a newer version. Otherwise, the error message "TRANSM. SW-DAT" appears after a restart, and the LOAD function is then no longer available.

SAVE:

Data are transferred from the EEPROM to the T-DAT.

6.3.4 Measuring the flow of solids

In certain areas of industry, raw materials that are very inhomogeneous or which contain considerable quantities of solids, are transported and processed on a daily basis. Ore slurry, plaster or viscous pulps are only some examples. When measuring flow in the mining industry or, for example, in applications with suction dredgers, it is often not just the volume flow in a pipeline that is of interest but also the proportion of solids being transported along.

To record this flow of solids, electromagnetic flow measurement is usually combined with radiometric density measurement (total fluid density). If the total fluid density, solids density (target fluid) and the density of the transported fluid (carrier fluid) are known, e.g. as a result of laboratory testing, both the volume and mass flow can be calculated in addition to the proportion of individual components in mass, volume or percentage units (→  47).

Solids content flow measurement using Promag 55

Promag 55S has special functions for calculating the flow of solids. In order to do so, the following preconditions must be met:

- "Solids content flow" software option (F-CHIP)
- Analog Output function block (AO)
- A density measuring device, e.g. "Gammapilot M" from Endress+Hauser, for recording total fluid density (i.e. incl. solids)
- Knowledge of the density of the solids, e.g. resulting from laboratory testing
- Knowledge of the density of the transport fluid, e.g. resulting from laboratory testing or from reference tables (e.g. for water at 22 °C)

The following process variables can be calculated using Promag 55 and issued as an output signal:

- Volume flow total fluid (transport fluid + solids)
- Volume flow carrier fluid (transported fluid: e.g. water)
- Volume flow target fluid (transported solids: e.g. stone, sand, lime powder etc.)
- Mass flow total fluid
- Mass flow carrier fluid
- Mass flow target fluid
- % proportion of carrier fluid (volume or mass)
- % proportion of target fluid (volume or mass)

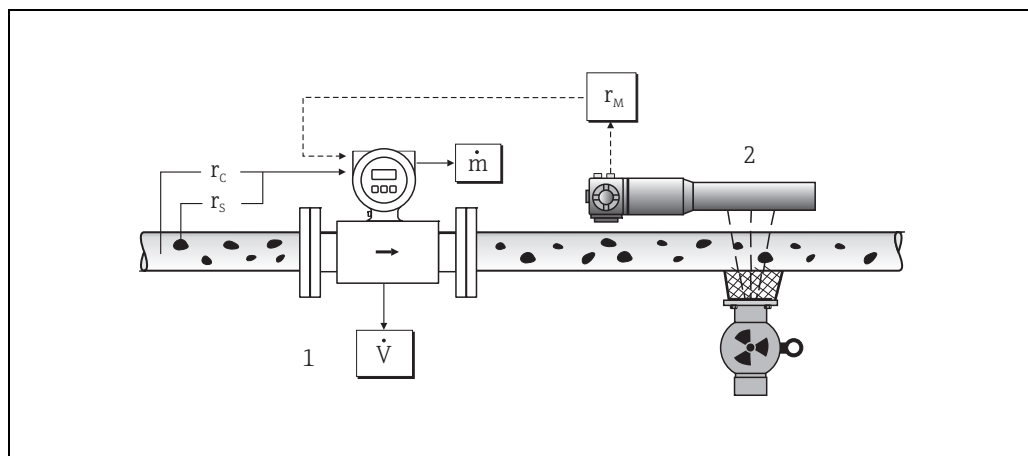

Fig. 47: Solids content flow measurement (\dot{m}) using a density and flow measuring device. If the density of the solids (ρ_s) and of the transport fluid (ρ_c) are also known, these can be used to calculate the solids content flow.

- 1 Flowmeter (Promag 55S) → Volume flow (\dot{V}). The density of the solids (ρ_s) and of the transported fluid (ρ_c) must also be entered into the transmitter.
- 2 Density measuring device (e.g. "Gammapilot M") → Total fluid density ρ_M (transport fluid and solids)

Formula for calculation (example)

The mass flow of the target fluid is calculated as follows:

$$m_Z = V \cdot (\rho_M - \rho_C) - (1 - \rho_C/\rho_S)$$

m_Z = Mass flow target fluid (solids), e.g. in kg/h

V = Volume flow (total fluid), e.g. in m³/h

ρ_C = Density of carrier fluid (transport fluid: e.g. water)

ρ_S = Density of target fluid (transported solids: e.g. stone, sand, lime powder etc.)

ρ_M = Total density of fluid

Configuration of solids content flow function

Please note the following points when commissioning the solids content flow function:

1. Please ensure that the settings in the following functions are identical in both the flow measuring device and the external density measuring device:
 - ASSIGN ANALOG OUTPUT (AO)
2. Then enter the following density values:
SPECIAL FUNCTIONS > SOLID CONTENT FLOW > CONFIGURATION > CARRIER DENSITY (7711) and TARGET MAT. DENSITY (7712)
3. Enter the desired density unit:
MEASURED VARIABLES > SYSTEM UNITS > ADDITIONAL CONFIGURATION > UNIT DENSITY (0420)
4. If necessary, assign the relevant measured variables for solids content flow to a display line or an output (current, frequency, relay). For process control, you may also assign freely definable limit values to the solids content flow (→ see the following examples).

Case study 1:

You would like to configure the totalizer for totaling the overall mass flow rate of solids (e.g. in tons).

1. Open the ASSIGN function for the totalizer (> TOTALIZER > CONFIGURATION > ASSIGN).
2. Assign the TARGET MASS FLOW variable to the totalizer.

Case study 2:

You would like to issue a warning via the relay, in case the solids content flow exceeds 60% of the total mass flow (transport fluid + solids).

1. Open the ASSIGN function for the relay output (> OUTPUTS > RELAY OUTPUT > CONFIGURATION > ASSIGN).
2. In addition, assign the LIMIT VALUE % TARGET MASS FLOW measured variable to the relay output.
3. Using the ON-VAL.LF-CUTOFF or OFF-VAL.LF-CUTOFF function, you can then enter the desired percentage value (%) for the maximum permitted solid content flow (e.g. switch on at 65% solids content; switch off at 55% solids content).

6.3.5 Advanced diagnostic functions

Using the optional software package "Advanced Diagnostics" (F-CHIP, accessories →  77), changes in the measuring system can be detected early, e.g. changes due to buildup or corrosion on the measuring electrodes. Such factors usually reduce the accuracy of measurement or, in extreme cases, result in system errors.

Using diagnostic functions, it is possible to record different diagnostic parameters during operation – e.g. electrode potentials of measuring electrodes 1 and 2, decay times for test pulses at electrodes 1 and 2 (as an indicator of possible buildup) etc. By analyzing trends in these measured values, deviations in the measuring system compared to a "reference status" can be detected early and the necessary measures taken.



Note!

Further information on this can be found in the "Description of Device Functions" manual.

Reference values as the basis for trend analyses

For trend analyses, reference values must always be recorded for the relevant diagnostic parameters. These must be determined under reproducible and constant conditions. These reference values are recorded for the first time during calibration at the factory and are stored in the measuring device.

However, reference data should also be collected under customer-specific process conditions, e.g. during commissioning or directly afterwards. The recording and saving of reference values in the measuring system is always performed using the REFERENCE STATUS USER (7501) device function.



Caution!

An analysis of trends in diagnostic parameters without reference values is not possible! Reference values should always be determined directly after commissioning. This ensures that the saved reference values are values in the "original status" of the measuring system - i.e. which have not yet been influenced by existing buildup or corrosion.

Type of data collection

There are two different ways to record diagnostic parameters, and you can set these in the ACQUISITION MODE (7510) function:

- PERIODICAL option: Data acquisition is carried out periodically by the measuring device. The desired time interval is entered using the ACQUISITION PERIOD (7511) function.
- SINGLE SHOT option: Data acquisition is carried out manually by the user at arbitrary points in time.



Note!

In the measuring system, the last 10 diagnostic parameter values recorded are stored in chronological order. The "history" of these parameter values can be called up using different functions:

Diagnostic parameters of the function groups *	Saved data records (for each diagnostic parameter)
COATING 1 COATING 2 ELECTRODE POTENTIAL 1 ELECTRODE POTENTIAL 2 VOLUME FLOW NOISE VALUE	Reference value → REFERENCE VALUE function Actual value → ACTUAL VALUE function Smallest measured value → MINIMUM VALUE function Highest measured value → MAXIMUM VALUE function List of the two (or hundred) previous measured values → HISTORY function Deviation, measurement/reference → ACTUAL DEVIATION function
* Further information on this can be found in the "Description of Device Functions" manual.	

Activating warnings

All diagnostic parameters can be assigned a limit value if necessary. If this limit value is exceeded, a warning is activated → WARNING MODE (7503) function.

The limit value is input into the measuring system as an absolute (+/-) or relative deviation compared to the reference value → WARNING (75....) function.

Deviations which occur and which are recorded by the measuring system may also be output via the current or relay outputs.

Interpretation of data

The interpretation of data records recorded by the measuring system greatly depends on the application in question. This requires that the users have an exact knowledge of their process conditions and the associated deviation tolerances in the process. In individual cases, these must be determined by the users themselves.

For example, in order to use the limit function, a knowledge of the permitted minimum and maximum deviation tolerances is of particular importance. Otherwise, there is the risk that a warning may be activated unintentionally in the case of "normal" process fluctuations.

Deviations from the reference status can happen for different reasons. The following table contains examples and notes for each of the six diagnostic parameters recorded:

Function group (diagnostic parameters)	Possible causes of deviations from the reference value
COATING 1	A deviation from the reference value may be caused by the following: <ul style="list-style-type: none"> ■ Formation of buildup on measuring electrode 1 ■ Electrical interruption ■ Short-circuit
COATING 2	A deviation from the reference value may be caused by the following: <ul style="list-style-type: none"> ■ Formation of buildup on measuring electrode 2 ■ Electrical interruption ■ Short-circuit
ELECTRODE POTENTIAL 1	A change in the electrode potential may be caused by the following: <ul style="list-style-type: none"> ■ Corrosion processes on measuring electrode 1 ■ Stronger fluctuations in the pH of the fluid ■ Formation of air bubbles on measuring electrode 1 ■ Mechanical shocks to the measuring electrode due to solids ■ Electrical interruption ■ Short-circuit
ELECTRODE POTENTIAL 2	A change in the electrode potential may be caused by the following: <ul style="list-style-type: none"> ■ Corrosion processes on measuring electrode 2 ■ Stronger fluctuations in the pH of the fluid ■ Air bubbles on measuring electrode 2 ■ Mechanical shocks to the measuring electrode due to solids ■ Electrical interruption ■ Short-circuit
VOLUME FLOW	The volume flow is additional information that is required in order to be able to assess the other diagnostic parameters sufficiently.
NOISE VALUE	A change in the noise value may be caused by the following: <ul style="list-style-type: none"> ■ Corrosion processes on the measuring or reference electrodes ■ Air bubbles ■ Mechanical shocks to the measuring electrodes due to solids



Note!

In order to assess the possible formation of buildup, the diagnostic parameters of the COATING 1 and COATING 2 function groups must be interpreted and evaluated only in conjunction with those under ELECTRODE POTENTIAL 1 and 2 and VOLUME FLOW. As the buildup typically develops over a period of months, it is useful to present and evaluate the relevant measured data and parameters using suitable software – for example using the Endress+Hauser software package "FieldCare" with the Flow Communication FXA193/291 DTM and Fieldsafe Module.

6.4 Adjustment

6.4.1 Empty pipe/full pipe adjustment

Flow cannot be measured correctly unless the measuring tube is full. This state can be permanently monitored by means of empty pipe detection (EPD).



Caution!

A **detailed** description and other helpful hints for the empty pipe/full pipe adjustment procedure can be found in the separate "Description of Device Functions" manual:

- EPD ADJUSTMENT (6480) → Carrying out the adjustment.
- EMPTY PIPE DET. (6420) → Switching EPD on and off
- EPD RESPONSE TIME (6425) → Input of the response time for EPD



Note!

- The EPD function is not available unless the sensor is fitted with an EPD electrode.
- The devices are already calibrated at the factory using water (approx. 500 $\mu\text{S}/\text{cm}$). If the fluid conductivity differs from this reference, empty pipe/full pipe adjustment must be performed again on site.
- The default setting for the EPD function when the devices are delivered is OFF; the function must be activated if required.
- The EPD process error can be output by means of the configurable relay outputs.

Performing empty pipe and full pipe adjustment (EPD)

1. Select the appropriate function in the function matrix:
HOME → → → BASIC FUNCTIONS → → → PROCESSPARAMETER
→ → → ADJUSTMENT → → EPD ADJUSTMENT
2. Empty the piping. For EPD empty pipe adjustment, the wall of the measuring tube should be wetted with fluid.
3. Start empty pipe adjustment: Select "EMPTY PIPE ADJUST" and confirm by pressing .
4. After empty pipe adjustment, fill the piping with fluid.
5. Start full pipe adjustment: Select "FULL PIPE ADJUST" and confirm by pressing .
6. Having completed the full pipe adjustment, select the "OFF" setting and exit the function by pressing .
7. Now select the EMPTY PIPE DET. function (6420). Switch on the empty pipe detection by selecting "ON STANDARD" and confirm by pressing .



Caution!

The adjustment coefficients must be valid before you can activate the EPD function. If adjustment is incorrect, the following messages might appear on the display:



- ADJUSTMENT FULL = EMPTY
The calibration values for empty pipe and full pipe are identical. In such cases you **must** repeat empty pipe or full pipe adjustment.
- ADJUSTMENT NOT OK
Adjustment is not possible because the fluid's conductivity is out of range.

Performing empty pipe/full pipe adjustment (with configuration program :)

1. Make sure that hardware write protection is switched off →  59.
2. In the configuration program, open the "Flow" Transducer Block (TRANSDUCER_FLOW_XXXXXXXXXX/base index: 1400).
3. Enable programming:
 - Enter the access code in the "Access – Code" parameter.
 - In the "Access – Status" parameter, the message "ACCESS CUSTOMER" should now appear.
4. Empty the piping. For the following empty pipe adjustment, the wall of the measuring tube should be wetted with fluid.
5. Start empty pipe adjustment:
 - In the "EPD – Adjustment" parameter, select the "Empty Pipe Adjust" setting.
 - Start the empty pipe adjustment by sending this setting to the field device.
6. After empty pipe adjustment, fill the piping with fluid.
7. Start full pipe adjustment when the medium is stagnant:
 - In the "EPD – Adjustment" parameter, select the "Full Pipe Adjust" setting.
 - Now start the full pipe adjustment by sending this setting to the field device.
8. On completion of the adjustment, select the setting "Off" and exit the function by sending this setting to the field device.
9. Now select the "EPD – Empty Pipe Detection" parameter. Switch on empty pipe detection by selecting the setting "ON (for EPD)" and sending the setting to the field device.

**Caution!**

The adjustment values must be valid before you can activate the EPD function. If the adjustment is incorrect, the following messages are output in the "Diagnosis" Transducer Block (base index: 1600) by means of the "Diag. – Act.Sys.Condition" parameter:

- EPD adjustment wrong – Err. No. 463
The adjustment values for empty pipe and full pipe are identical. In such cases you must repeat empty pipe or full pipe adjustment.
This error (→  88) is conveyed to the downstream function blocks by means of the "BAD" status of the AI Block output variable OUT.
- EPD adjustment not possible – Err. No. 461
Adjustment is not possible as the conductivity of the medium is outside the permitted range.
This error (→  88) is conveyed to the downstream function blocks by means of the "UNCERTAIN" status of the AI Block output variable OUT.

6.5 Data storage devices

At Endress+Hauser, the term HistoROM refers to various types of data storage modules on which process and measuring device data are stored. By plugging and unplugging such modules, device configurations can be duplicated onto other measuring devices to cite just one example.

6.5.1 HistoROM/S-DAT (sensor DAT)

The S-DAT is an exchangeable data storage device in which all sensor data are stored, i.e., nominal diameter, serial number, calibration factor, zero point.

6.5.2 HistoROM/T-DAT (transmitter DAT)

The T-DAT is an exchangeable data storage device in which all transmitter parameters and settings are stored.

Storing of specific parameter settings from the device memory (EEPROM) to the T-DAT module and vice versa must be carried out by the user (= manual save function). Detailed instructions regarding this can be found on →  68.

6.5.3 F-CHIP (function chip)

The F-CHIP is a microprocessor component which contains additional software packages which are used to enhance the functionality and therefore the range of application of the transmitter.

If an upgrade is carried out at a later stage, the F-CHIP can be ordered as an accessory and can simply be inserted into the I/O board. After startup, the transmitter can access this software immediately.

Accessories →  77

Inserting into the I/O board →  90



Caution!

To avoid any confusion, once the F-CHIP has been put on the I/O board, it is labeled with the transmitter's serial number i.e. the F-CHIP can then no longer be used for another measuring device.

7 Maintenance

No special maintenance work is required.

7.1 Exterior cleaning

When cleaning the exterior of measuring devices, always use cleaning agents that do not attack the surface of the housing or the seals.

7.2 Seals

The seals in the Promag H sensor should be replaced periodically, particularly when molded seals (aseptic version) are used!

The interval between replacements depends on the frequency of the cleaning cycles and on the temperature of the fluid and of the cleaning process.

Replacement seals (accessory) →  77.

8 Accessories

Various accessories, which can be ordered separately or with the device from Endress+Hauser, are available for the device. Detailed information can be provided by the Endress+Hauser service organization or can be found on the product page of the Endress+Hauser website: www.endress.com

8.1 Device-specific accessories

Accessory	Description	Order code
Transmitter Promag 55 FOUNDATION Fieldbus	Transmitter for replacement or for stock. Use the order code to define the following specifications: <ul style="list-style-type: none"> - Approvals - Degree of protection / version - Cable type for remote version - Cable entries - Display / power supply / operation - Software - Outputs / inputs 	55XXX - XXXXX * * * * * * * *
Software packages for Promag 55 FOUNDATION Fieldbus	Additional software on F-Chip can be ordered individually: <ul style="list-style-type: none"> - ECC electrode cleaning - Advanced diagnostics - Solids content flow 	DK5SO-X

8.2 Accessories specific to measuring principle

Accessory	Description	Order code
Mounting kit for Promag 55 transmitter	Mounting kit for wall-mount housing (remote version). Suitable for: <ul style="list-style-type: none"> ■ Wall mounting ■ Pipe mounting ■ Panel mounting Mounting set for aluminum field housing. Suitable for: <ul style="list-style-type: none"> ■ Pipe mounting 	DK5WM - * *
Cable for remote version	Coil current and electrode cables, various lengths. Reinforced cable on request.	DK5CA - * *
Ground cable for Promag S	A set consists of two ground cables.	DK5GC - * * *
Ground disk/liner protection plate for Promag S	Metal disk for potential equalization and/or for protecting the measuring tube lining.	DK5GD - * * * * *
Mounting kit for Promag H	Mounting kit for Promag H, consisting of: <ul style="list-style-type: none"> ■ 2 Process connections ■ Screws ■ Seals 	DKH * * - * * * *
Adapter connection for Promag A, H	Adapter connections for installing Promag 55H instead of Promag 30A, 33A or Promag 30H, 33H, DN 25.	DK5HA - * * * * * *
Grounding rings for Promag H	If the process connections are made of PVC or PVDF, ground rings are necessary to ensure that potential is matched. A set comprises 2 ground rings.	DK5HR - * * *
Seal set for Promag H	For regular replacement of seals in the Promag H sensor.	DK5HS - * * *

Accessory	Description	Order code
Wall mounting kit for Promag H	Wall mounting kit for Promag H transmitter.	DK5HM - **
Welding jig for Promag H	Weld nipple as process connection: Welding jig for installation in piping.	DK5HW - ***

8.3 Communication-specific accessories

Accessory	Description	Order code
Handheld terminal DXR375	Handheld terminal for remote parameterization and for fetching measured values via the FOUNDATION Fieldbus H1. Contact your Endress+Hauser representative for more information.	DXR375 - * * * *

8.4 Service-specific accessories

Accessory	Description	Order code
Applicator	Software for selecting and configuring flowmeters. Applicator can be downloaded from the Internet or ordered on CD-ROM for installation on a local PC. Contact your Endress+Hauser representative for more information.	DXA80 - *
Fieldcheck	Tester/simulator for testing flowmeters in the field. When used in conjunction with the "FieldCare" software package, test results can be imported into a database, printed and used for official certification. Contact your Endress+Hauser representative for more information.	50098801
FieldCare	FieldCare is Endress+Hauser's FDT-based plant asset management tool. It can configure all intelligent field devices in your plant and supports you in the administration of these devices. Through the use of status information, it is also an easy but effective means of monitoring the status of these devices.	See product list on the Endress+Hauser website: www.endress.com
FXA193	Service interface of device to the PC for operation via FieldCare.	FXA193 - *
Memograph M graphic display recorder	The Memograph M graphic display recorder provides information on all relevant process variables: Measuring values are recorded reliably, limit values monitored and measuring points analyzed. The data are stored in the 256 MB internal memory and also on an SD card or USB stick. The PC software package ReadWin® 2000, which is supplied as standard, is used for configuration, visualization and storage of the recorded data.	RSG40-*****

9 Troubleshooting

9.1 Troubleshooting instructions

If faults occur after commissioning or during operation, always start troubleshooting with the checklist below. The routine takes you directly to the cause of the problem and the appropriate remedial measures.



Caution!

In the event of a serious fault, a flowmeter might have to be returned to the manufacturer for repair. The necessary procedures must be carried out before you return the device to Endress+Hauser → 5.





Always enclose a duly completed "Declaration of Contamination" form. You will find a preprinted blank of this form at the back of this manual.

Check the display	
No display visible. No connection to the FF host system	<ol style="list-style-type: none"> 1. Check the supply voltage → Terminals 1, 2 2. Check device fuse → 95 20 to 260 V AC and 20 to 64 V DC: 2 A slow-blow / 250 V 3. Measuring electronics defective → Order spare part → 90
No display visible. Connection to the FF host system established however.	<ol style="list-style-type: none"> 1. Check whether the ribbon-cable connector of the display module is correctly plugged into the amplifier board → 90 2. Display module defective → Order spare part → 90 3. Measuring electronics defective → Order spare part → 90
Display texts are in a foreign language.	Switch off power supply. Then press the OS keys simultaneously to switch the device back on. The display text will appear in English (default) and is displayed at maximum contrast.
No connection can be established with the FF host system, even though measured value reading is visible.	Measuring electronics board defective → Order spare part → 90











Error messages on display	
Errors which occur during commissioning or operation are displayed immediately. Error messages consist of a variety of icons. The meanings of these icons are as follows (example): <ul style="list-style-type: none"> - Error type: S = system error, P = process error - Error message type: \$ = fault message, ! = notice message - EMPTY PIPE = type of error, e.g. measuring tube is only partly filled or completely empty - 03:00:05 = duration of error occurrence (in hours, minutes and seconds) - #401 = error number 	
Caution! <ul style="list-style-type: none"> ▪ Also observe the information on → 56 ▪ The measuring system interprets simulations and positive zero return as system errors, but displays them only as a notice message. 	
Error number: No. 001 - 399 No. 501 - 699	System error (device error) has occurred → 83
Error number: No. 401 - 499	Process error (application error) has occurred → 88



Faulty connection to the fieldbus host system	
No connection can be made between the fieldbus host system and the measuring device. Check the following points:	
Supply voltage Transmitter	Check the supply voltage → Terminals 1/2.
Device fuse	Check device fuse →  95 20 to 260 V AC and 20 to 64 V DC: 2 A slow-blow / 250 V
Fieldbus connection	FOUNDATION Fieldbus: check the data cable Terminal 26 = FF + Terminal 27 = FF -
Fieldbus connector (Option)	<ul style="list-style-type: none"> ▪ Check pin assignment/wiring →  45. ▪ Check connection between connector/fieldbus port. Is the coupling ring tightened correctly?
Fieldbus voltage	Check that a min. bus voltage of 9 V DC is present at terminals 26/27. Permissible range: 9 to 32 V DC
Network structure	Check permissible fieldbus length and number of spurs →  36.
Basic current	Is there a basic current of min. 12 mA?
Bus address	Check bus address: make sure there are no double assignments.
Bus termination	Is the FOUNDATION Fieldbus H1 correctly terminated? Each bus segment must always be terminated with a bus terminator at both ends (start and finish). Otherwise there may be interference during data transmission.
Current consumption, permitted feed current	Check the current consumption of the bus segment: The current consumption of the bus segment in question (= total of basic currents of all bus users) must not exceed the max. permissible feed current of the bus power supply.
Device Description (DD)	<p>Instal the DD if you cannot access the manufacturer-specific parameters.</p> <p> Note! Ensure you use the correct system files for linking the field devices into the host system. Appropriate version information can be called up in the measuring device via the following functions/parameters:</p> <p>Local display:</p> <ul style="list-style-type: none"> ▪ HOME → BASIC FUNCTION → FOUND. FIELDBUS → INFORMATION → DEVICE REVISION (6243) ▪ HOME → BASIC FUNCTION → FOUND. FIELDBUS → INFORMATION → DD REVISION (6244) <p>FF configuration program:</p> <ul style="list-style-type: none"> ▪ Resource Block → Parameter DEV_REV ▪ Resource Block → Parameter DD_REV <p>Example (local display): Displayed in the DEVICE REVISION (6243) function → 04 Displayed in the DD REVISION (6244) function → 01 Device description file (DD) required → 0401.sym / 0401.ffo</p>



Problems with configuration of function blocks	
<p>Transducer Blocks: The operating mode cannot be set to AUTO.</p>	<p>Check whether the operating mode of the Resource Block is in AUTO mode → MODE_BLK parameter group / TARGET parameter.</p>
<p>Analog Input function block: The operating mode cannot be set to AUTO.</p>	<p>There may be several reasons for this. Check the following in sequence:</p> <ol style="list-style-type: none"> 1. Check whether the operating mode of the Analog Input function block is in AUTO mode → MODE_BLK parameter group / TARGET parameter. If not and the mode cannot be set to AUTO, first check the following. 2. Please ensure that the CHANNEL parameter (process variable option) is already configured in the Analog Input function block → 90. The option CHANNEL = 0 (uninitialized) is not valid. 3. Make sure that the XD_SCALE parameter group (input range, unit) is already configured in the Analog Input function block → 90 (incl. configuration example) <p> Caution! Make sure that the selected unit is suitable for the process variable selected in the CHANNEL parameter. Otherwise the BLOCK_ERROR parameter will display the error message "Block Configuration Error". In this status the block operating mode cannot be set to AUTO.</p> 4. Make sure that the L_TYPE parameter (type of linearization) is already configured in the Analog Input function block → 90. <p> Caution! Make sure that with in the case of the "Direct" type of linearization, the scaling of the OUT_SCALE parameter group is identical to that of the XD_SCALE parameter group. If set incorrectly, the BLOCK_ERROR parameter will display the error message "Block Configuration Error". In this status, the operating mode cannot be set to AUTO. Configuration example → 90</p> 5. Check whether the operating mode of the Resource Block is set to AUTO → MODE_BLK parameter group / TARGET parameter. 6. Make sure that the function blocks are correctly interconnected and that this system configuration has been sent to the fieldbus users → 90.
<p>Analog Input function block: The operating mode is set to AUTO, but the status of the AI output value OUT is "BAD" or "UNCERTAIN".</p>	<ol style="list-style-type: none"> 1. Check whether the operating mode of the Transducer Blocks is set to AUTO → MODE_BLK parameter group / TARGET parameter. Use the different CHANNEL parameters to set the Transducer Blocks (→ 97) to AUTO. 2. Check if there is a fault in the "Diagnosis" Transducer Block (base index: 1600) → "Diagnosis" Transducer Block (base index: 1600) → "Diag. - Act.Sys.Condition" parameter. <p>Error messages → 83</p>

<p>Parameters cannot be modified, or no write access to parameters.</p>	<ol style="list-style-type: none"> 1. Parameters that display only values or settings cannot be modified! 2. Hardware write protection is enabled → Disable write protection →  90.  Note! You can use the WRITE_LOCK parameter in the Resource Block to check whether hardware write protection is enabled or disabled: LOCKED = write protection activated (enabled) UNLOCKED = no write protection (disabled) 3. The block operating mode is wrong. Certain parameters can only be modified in OOS (Out of Service) or MAN (MANual) mode → Set the operating mode of the block to the required mode → MODE_BLK parameter group. 4. The value entered is outside the specified input range for the parameter in question: → Enter suitable value → Increase input range if necessary 5. Transducer Blocks: The programming level is not enabled → Enable by entering the code in the "Access - Code" parameter or by means of the service code in the service parameters.
<p>Transducer Block: The manufacturer-specific parameters are not visible.</p>	<p>The device description file (Device Description, DD) has not yet been loaded into the host system or the configuration program → Download the file into the configuration system.</p> <p>Reference sources of the DD →  90</p> <p> Note! Ensure you use the correct system files for linking the field devices into the host system. Appropriate version information can be called up in the measuring device via the following functions/parameters:</p> <p>Local display:</p> <ul style="list-style-type: none"> ■ HOME → BASIC FUNCTION → FOUND. FIELDBUS → INFORMATION → DEVICE REVISION (6243) ■ HOME → BASIC FUNCTION → FOUND. FIELDBUS → INFORMATION → DD REVISION (6244) <p>FF interface:</p> <ul style="list-style-type: none"> ■ Resource Block → Parameter DEV_REV ■ Resource Block → Parameter DD_REV <p>Example (local display): Displayed in the DEVICE REVISION (6243) function → 04 Displayed in the DD REVISION (6244) function → 01 Required device description file (DD) → 0401.sym / 0401.ffe</p>
<p>Analog Input function block: The output value OUT is not updated despite having a valid "GOOD" status.</p>	<p>Simulation is active → Deactivate simulation via SIMULATE parameter group.</p>
<p>Error messages</p>	
<p>Error messages in the FF configuration program →  83 Error messages on the local display →  83</p>	
<p>▼</p>	
<p>Other errors (without error message)</p>	
<p>Some other errors have occurred.</p>	<p>Diagnosis and rectification →  89</p>

9.2 System/process error messages

General notes

The device assigns current system and process errors to two error message types, with the result that they are evaluated differently:

"Fault message" error message type:

- A message of this type immediately interrupts or stops measurement.
- Presentation on the FOUNDATION Fieldbus → Fault messages are transmitted to downstream function blocks or higher-level process control systems using the "BAD" status of the AI output parameter OUT.
- Local display → A flashing lightning symbol (⚡) is displayed

"Notice message" error message type:

- Measurement continues despite this message.
- Presentation on the FOUNDATION Fieldbus → Notice messages are transmitted to downstream function blocks or higher-level process control systems using the "UNCERTAIN" status of the AI output parameter OUT.
- Local display → A flashing exclamation mark (!) is displayed.

Critical system errors, e.g. defects in the electronics module, are always identified and displayed as "fault messages" by the measuring device. Simulations in the "Flow" Transducer Block and positive zero return, on the other hand, are identified by the measuring system as "notice messages" only.

Error messages in the FF configuration programs → See Table

In the Promag 55, system and process errors are recognized and reported in the Transducer Blocks. Such errors are displayed via the following parameters defined in the FOUNDATION Fieldbus specification:

- BLOCK_ERR
- Transducer Error

In the "Diagnosis" Transducer Block (base index: 1600), detailed causes of errors and device status messages are displayed by means of the "Diag. - Act.Sys.Condition" parameter (manufacturer-specific) → Table.

Error messages on the local display → See table

You will find more details on how error messages are presented on →  56.

9.2.1 List of system error messages

No.	Error messages: FOUNDATION Fieldbus (FF)* (local display)	Transducer Block error messages	Analog Input function block error messages	Cause/remedy
<p>* With FF, error messages are displayed in the "Diagnosis" Transducer Block (base index: 1600) by means of the "Diag. - Act.Sys.Condition" parameter (manufacturer-specific).</p> <p>§ = System error ⚡ = Fault message (with an effect on operation) ! = Notice message (without an effect on operation)</p>				
No. # 0xx → Hardware error				
001	Device status message (FF): ROM/RAM failure – Err. No. 001 Local display: §: CRITICAL FAIL. ⚡: # 001	BLOCK_ERR = Device needs maintenance now	OUT. QUALITY = BAD	Cause: ROM/RAM error. Error when accessing the program memory (ROM) or random access memory (RAM) of the processor. Remedy: Replace the amplifier board. Spare parts → 📦 91
		Transducer_Error = Electronics failure	OUT. SUBSTATUS = Device Failure	
			BLOCK_ERR = Input Failure (faulty input value from Transducer Blocks)	
011	Device status message (FF): Amplifier EEPROM failure – Err. No. 011 Local display: §: AMP HW EEPROM ⚡: # 011	BLOCK_ERR = Device needs maintenance now	OUT. QUALITY = BAD	Cause: Amplifier with faulty EEPROM Remedy: Replace the amplifier board. Spare parts → 📦 91
		Transducer_Error = Data integrity error	OUT. SUBSTATUS = Device Failure	
			BLOCK_ERR = Input Failure (faulty input value from Transducer Blocks)	
012	Device status message (FF): Amplifier EEPROM data inconsistent – Err. No. 012 Local display: §: AMP SW EEPROM ⚡: # 012	BLOCK_ERR = Device needs maintenance now	OUT. QUALITY = BAD	Cause: Error when accessing data of EEPROM measuring amplifier Remedy: Perform a "warm restart" (i.e. restart the measuring system without disconnecting mains power). <ul style="list-style-type: none"> ▪ FF: "Diagnosis" Transducer Block (base index: 1600) → "Sys. - Reset" RESTART SYSTEM parameter ▪ Local display: SUPERVISION → SYSTEM → OPERATION → SYSTEM RESET (→ RESTART SYSTEM)
		Transducer_Error = Data integrity error	OUT. SUBSTATUS = Device Failure	
			BLOCK_ERR = Input Failure (faulty input value from Transducer Blocks)	
031	Device status message (FF): S-DAT failure / S-DAT not inserted – Err. No. 031 Local display: §: SENSOR HW DAT ⚡: # 031	BLOCK_ERR = Device needs maintenance now	OUT. QUALITY = BAD	Cause: 1. S-DAT is not correctly plugged into the amplifier board (or is missing). 2. S-DAT is defective. Remedy: 1. Check whether the S-DAT is correctly plugged into the amplifier board, 2. Replace the S-DAT if it is defective. Spare parts → 📦 90 Check whether the new replacement DAT is compatible with the existing electronics. Check the: - Spare part set number - Hardware revision code 3. Replace measuring electronics boards if necessary Spare parts → 📦 90 4. Plug the S-DAT into the amplifier board.
		Transducer_Error = Electronics failure	OUT. SUBSTATUS = Device Failure	
			BLOCK_ERR = Input Failure (faulty input value from Transducer Blocks)	
032	Device status message (FF): S-DAT data inconsistent – Err. No. 032 Local display: §: SENSOR SW DAT ⚡: # 032	BLOCK_ERR = Device needs maintenance now	OUT. QUALITY = BAD	Cause: 1. S-DAT is not correctly plugged into the amplifier board (or is missing). 2. S-DAT is defective. Remedy: 1. Check whether the S-DAT is correctly plugged into the amplifier board, 2. Replace the S-DAT if it is defective. Spare parts → 📦 90 Check whether the new replacement DAT is compatible with the existing electronics. Check the: - Spare part set number - Hardware revision code 3. Replace measuring electronics boards if necessary Spare parts → 📦 90 4. Plug the S-DAT into the amplifier board.
		Transducer_Error = Data integrity error	OUT. SUBSTATUS = Device Failure	
			BLOCK_ERR = Input Failure (faulty input value from Transducer Blocks)	

No.	Error messages: FOUNDATION Fieldbus (FF)* (local display)	Transducer Block error messages	Analog Input function block error messages	Cause/remedy
041	<i>Device status message (FF):</i> T-DAT failure – Err. No. 041 <i>Local display:</i> S: TRANSM. HW-DAT !: # 041	BLOCK_ERR = Device needs maintenance now	OUT. QUALITY = BAD	<i>Cause:</i> 1. T DAT is not correctly plugged into the amplifier board (or is missing). 2. T-DAT is defective.
		Transducer_Error = Electronics failure	OUT. SUBSTATUS = Device Failure	<i>Remedy:</i> 1. Check whether the T-DAT is correctly plugged into the amplifier board.
			BLOCK_ERR = Input Failure (faulty input value from Transducer Blocks)	2. Replace the T-DAT if it is defective. Spare parts → 90 Check whether the new replacement DAT is compatible with the existing electronics. Check the: - Spare part set number - Hardware revision code
042	<i>Device status message (FF):</i> T-DAT data inconsistent – Err. No. 042 <i>Local display:</i> S: TRANSM. SW-DAT !: # 042	BLOCK_ERR = Device needs maintenance now	OUT. QUALITY = BAD	3. Replace measuring electronics boards if necessary Spare parts → 90 4. Plug the T-DAT into the amplifier board.
		Transducer_Error = Data integrity error	OUT. SUBSTATUS = Device Failure	
			BLOCK_ERR = Input Failure (faulty input value from Transducer Blocks)	
No. # 1xx → Software error				
101	<i>Device status message (FF):</i> GAIN ERROR AMPLIFIER – Err. No. 101 <i>Local display:</i> S: GAIN ERROR AMP. !: # 101	BLOCK_ERR = Device needs maintenance now	OUT. QUALITY = BAD	<i>Cause:</i> Gain deviation compared to reference gain is greater than 2%. <i>Remedy:</i> Replace the amplifier board → 90
		Transducer_Error = Electronics failure	OUT. SUBSTATUS = Device Failure	
			BLOCK_ERR = Input Failure (faulty input value from Transducer Blocks)	
121	<i>Device status message (FF):</i> Software compatibility problem amplifier – I/O module – Err. No. 121 <i>Local display:</i> S: A/C COMPATIB. !: # 121	BLOCK_ERR = Device needs maintenance now	OUT. QUALITY = BAD	<i>Cause:</i> Due to different software versions, I/O board and amplifier board are only partially compatible (possibly restricted functionality). <i>Note!</i> – Appears on the display as a notice message for only 30 seconds (with listing in "Previous system condition" function). – This occurrence of different software versions can occur if only one electronics board has been replaced; the extended software functionality is not available. The previously existing software functionality is still working and the measurement possible. <i>Remedy:</i> Module with lower software version must either be updated by "FieldCare" using the required (recommended) software version, or the module must be replaced. → 90
		Transducer_Error = I/O failure (input/output error)	OUT. SUBSTATUS = Device Failure	
			BLOCK_ERR = Input Failure (faulty input value from Transducer Blocks)	

No.	Error messages: FOUNDATION Fieldbus (FF)* (local display)	Transducer Block error messages	Analog Input function block error messages	Cause/remedy
No. # 2xx → Error in DAT / no communication				
205	<i>Device status message (FF):</i> Save to T-DAT failed – Err. No. 205 <i>Local display:</i> S: LOAD T-DAT !: # 205	BLOCK_ERR = Device needs maintenance now	OUT. QUALITY = BAD	<i>Cause:</i> Data backup (downloading) to T-DAT failed, or error when accessing (uploading) the calibration values stored in the T-DAT. <i>Remedy:</i> 1. Check whether the T-DAT is correctly plugged into the amplifier board. 2. Replace the T-DAT if it is defective → 90 Before replacing the DAT, check that the new, replacement DAT is compatible with the existing electronics. Check the: – Spare part set number – Hardware revision code 3. Replace measuring electronics boards if necessary → 90
		Transducer_Error = Electronics failure	OUT. SUBSTATUS = Device Failure	
			BLOCK_ERR = Input Failure (faulty input value from Transducer Blocks)	
206	<i>Device status message (FF):</i> Restore from T-DAT failed – Err. No. 206 <i>Local display:</i> S: SAVE T-DAT !: # 206	BLOCK_ERR = Device needs maintenance now	OUT. QUALITY = BAD	
		Transducer_Error = Electronics failure	OUT. SUBSTATUS = Device Failure	
			BLOCK_ERR = Input Failure (faulty input value from Transducer Blocks)	
261	<i>Device status message (FF):</i> Communication failure I/O – Err. No. 261 <i>Local display:</i> S: COMMUNICAT. I/O !: # 261	BLOCK_ERR = Device needs maintenance now	OUT. QUALITY = BAD	<i>Cause:</i> Communication error. No communication between amplifier and I/O board or faulty internal data transfer. <i>Remedy:</i> Check whether the electronics boards are correctly inserted in their holders → 91
		Transducer_Error = I/O failure (communication problems)	OUT. SUBSTATUS = Device Failure	
			BLOCK_ERR = Input Failure (faulty input value from Transducer Blocks)	
No. # 3xx → System limits exceeded				
321	<i>Device status message (FF):</i> Coil current out of tolerance – Err. No. 321 <i>Local display:</i> S: TOL. COIL CURR. !: # 321	BLOCK_ERR = Device needs maintenance now	OUT. QUALITY = BAD	<i>Cause:</i> The coil current of the sensor is out of tolerance. <i>Remedy:</i> ⚠ Warning! Switch off power supply before manipulating the coil current cable, coil current cable connector or measuring electronics boards! Remote version: 1. Check wiring of terminals 41/42 → 38 2. Check coil current cable connector. Compact and remote version: Replace measuring electronics boards if necessary → 90.
		Transducer_Error = Mechanical failure	OUT. SUBSTATUS = Device Failure	
			BLOCK_ERR = Input Failure (faulty input value from Transducer Blocks)	
No. # 5xx → Application error				

No.	Error messages: FOUNDATION Fieldbus (FF)* (local display)	Transducer Block error messages	Analog Input function block error messages	Cause/remedy
501	<i>Device status message (FF):</i> Download device software active – Err. No. 501 <i>Local display:</i> S: SW.-UPDATE ACT. !: # 501	BLOCK_ERR = Device needs maintenance now	OUT. QUALITY = UNCERTAIN	<i>Cause:</i> New amplifier or communication software version is loaded into device. Currently no other functions are possible. <i>Remedy:</i> Wait until the procedure is finished. The device will restart automatically.
		Transducer_Error = General Error	OUT. SUBSTATUS = Device Failure	
			BLOCK_ERR = Input Failure (faulty input value from Transducer Blocks)	
502	<i>Device status message (FF):</i> Up-/download device software active – Err. No. 502 <i>Local display:</i> S: UP-/DOWNLO. ACT. !: # 502	BLOCK_ERR = Device needs maintenance now	OUT. QUALITY = UNCERTAIN	<i>Cause:</i> Uploading or downloading the device data via operating program. Currently no other functions are possible. <i>Remedy:</i> Wait until the procedure is finished.
		Transducer_Error = General Error	OUT. SUBSTATUS = Device Failure	
			BLOCK_ERR = Input Failure (faulty input value from Transducer Blocks)	
No. # 6xx → Simulation mode active				
601	<i>Device status message (FF):</i> Positive zero return active – Err. No. 601 <i>Local display:</i> S: POS. ZERO-RETURN !: # 601		OUT. QUALITY = UNCERTAIN	<i>Cause:</i> Positive zero return is active.  Note! This notice message has the highest display priority! <i>Remedy:</i> Deactivate positive zero return: <ul style="list-style-type: none"> ■ FF: "Flow" Transducer Block (base index: 1100) → "System - Positive Zero Return" parameter → OFF ■ Local display: BASIC FUNCTIONS → SYSTEM PARAMETERS → CONFIGURATIONS → → POS. ZERO RETURN (→ OFF)
			OUT. SUBSTATUS = Nonspecific	
691	<i>Device status message (FF):</i> Simulation failsafe active – Err. No. 691 <i>Local display:</i> S: SIM. FAILSAFE !: # 691	BLOCK_ERR = Simulation active	OUT. QUALITY = UNCERTAIN	<i>Cause:</i> Simulation of failsafe mode (outputs) is active. <i>Remedy:</i> Switch off simulation: <ul style="list-style-type: none"> ■ FF: "Diagnosis" Transducer Block (base index: 1600) → "Sys. – Sim.Failsafe Mode" parameter → OFF ■ Local display: SUPERVISION → SYSTEM → OPERATION → SIM. FAILSAFE MODE (→ OFF)
			OUT. SUBSTATUS = Nonspecific	
			BLOCK_ERR = Simulation active	
692	<i>Device status message (FF):</i> Simulation volume flow active – Err. No. 692 <i>Local display:</i> S: SIM. MEASURAND !: # 692	BLOCK_ERR = Simulation active	OUT. QUALITY = UNCERTAIN	<i>Cause:</i> Simulation of the measured value is active. <i>Remedy:</i> Switch off simulation: <ul style="list-style-type: none"> ■ FF: "Flow" Transducer Block (base index: 1400) → "Simulation - Measurand" parameter → OFF ■ Local display: SUPERVISION → SYSTEM → OPERATION → SIM. MEASURAND (→ OFF)
			OUT. SUBSTATUS = Nonspecific	
			BLOCK_ERR = Simulation active	

No.	Error messages: FOUNDATION Fieldbus (FF)* (local display)	Transducer Block error messages	Analog Input function block error messages	Cause/remedy
-	No communication to amplifier	BLOCK_ERR = Device needs maintenance now	OUT. QUALITY = BAD	<i>Cause:</i> Communication error. No communication with measuring amplifier. <i>Remedy:</i> 1. Switch power supply off and on again. 2. Check whether the electronics boards are correctly inserted in their holders → 91
		Transducer_Error = General Error	OUT. SUBSTATUS = Device Failure	
			BLOCK_ERR = Input Failure (faulty input value from Transducer Blocks)	

9.2.2 List of process error messages

No.	Error messages: FOUNDATION Fieldbus (FF)* (local display)	Transducer Block error messages	Analog Input function block error messages	Cause/remedy
* With FF, error messages are displayed in the "Diagnosis" Transducer Block (base index: 1600) by means of the "Diag. - Act.Sys.Condition" parameter (manufacturer-specific). P = Process error ⚡ = Fault message (with an effect on operation) ! = Notice message (without an effect on operation)				
401	<i>Device status message (FF):</i> Empty pipe detected – Err. No. 401 <i>Local display:</i> P: EMPTY PIPE ⚡: # 401		OUT. QUALITY = UNCERTAIN OUT. SUBSTATUS = Non specific	<i>Cause:</i> Measuring tube partially filled or empty. <i>Remedy:</i> 1. Check the process conditions of the plant. 2. Fill the measuring tube.
461	<i>Device status message (FF):</i> EPD adjustment not possible – Err. No. 461 <i>Local display:</i> P: ADJ. NOT OK !: # 461	Transducer_Error = Configuration error	OUT. QUALITY = UNCERTAIN OUT. SUBSTATUS = Non specific	<i>Cause:</i> EPD adjustment not possible because the fluid's conductivity is either too low or too high. <i>Remedy:</i> The EPD function cannot be used with fluids of this nature.
463	<i>Device status message (FF):</i> EPD adjustment wrong – Err. No. 463 <i>Local display:</i> P: FULL = EMPTY ⚡: # 463	Transducer_Error = Configuration error	OUT. QUALITY = BAD OUT. SUBSTATUS = Configuration error BLOCK_ERR = Input Failure (faulty input value from Transducer Blocks)	<i>Cause:</i> The EPD adjustment values for empty pipe and full pipe are identical and therefore incorrect. <i>Remedy:</i> Repeat adjustment, making sure procedure is correct → 73.
467	<i>Device status message (FF):</i> AO Block Error – Err. No. 467 <i>Local display:</i> P: AO-BLOCK ERROR ⚡: # 467	BLOCK_ERR = Device needs maintenance now Transducer_Error = Data integrity error	OUT.QUALITY = BAD OUT.SUBSTATUS = Device Failure	<i>Cause:</i> The value transmitted to the AO block is 0. <i>Remedy:</i> Please ensure that the value transmitted to the AO block is greater than 0 → 63.

9.3 Process errors without a message

Symptoms	Rectification
 Note! You may have to change or correct certain settings in functions in the function matrix in order to rectify the fault. The functions outlined below, such as DISPLAY DAMPING, are described in detail in the "Description of Device Functions" manual.	
Flow values are negative, even though the fluid is flowing forwards through the pipe.	Change the sign of the flow rate variable. <ol style="list-style-type: none"> FF: "Flow" Transducer Block (base index: 1400) → "Sys. – Install.Direction Sensor" parameter Local display: HOME → BASIC FUNCTION → SYSTEM PARAMETER → CONFIGURATION → INSTALLATION DIRECTION SENSOR
Measured value reading fluctuates even though flow is steady.	<ol style="list-style-type: none"> Check grounding and potential equalization →  46 The medium is too inhomogeneous. Check the following medium characteristics: <ul style="list-style-type: none"> Gas bubble percentage too high? Solids percentage too high? Conductivity fluctuations too high? Increase the value for system damping: <ul style="list-style-type: none"> FF: Analog Input function block → PV_FTIME parameter FF: "Flow" Transducer Block (base index: 1400) → "Sys. – Flow Damping" parameter Local display: HOME → BASIC FUNCTION → SYSTEM PARAMETER → CONFIGURATION → SYSTEM DAMPING Increase the value for display damping: <ul style="list-style-type: none"> FF: "Display" Transducer Block (base index: 1800) → "Config. – Display Damping" parameter Local display: HOME → USER INTERFACE → CONTROL → BASIC CONFIG. → DISPLAY DAMPING
Measured-value reading or measured-value output pulsates or fluctuates, e.g. because of reciprocating pump, peristaltic pump, diaphragm pump or pump with similar delivery characteristic.	<ol style="list-style-type: none"> Increase the value for system damping: <ul style="list-style-type: none"> FF: Analog Input function block → PV_FTIME parameter FF: "Flow" Transducer Block (base index: 1400) → "Sys. – Flow Damping" parameter Local display: HOME → BASIC FUNCTION → SYSTEM PARAMETER → CONFIGURATION → SYSTEM DAMPING Increase the value for display damping: <ul style="list-style-type: none"> FF: "Display" Transducer Block (base index: 1800) → "Config. – Display Damping" parameter Local display: HOME → USER INTERFACE → CONTROL → BASIC CONFIG. → DISPLAY DAMPING
Measured value reading shown on display, even though the fluid is at a standstill and the measuring tube is full?	<ol style="list-style-type: none"> Check grounding and potential equalization →  46 Check the fluid for presence of gas bubbles. Enter or increase the value (>0) for the switching point of low flow cutoff: <ul style="list-style-type: none"> FF: "Flow" Transducer Block (base index: 1400) → "Low Flow Cut Off – On Value" parameter Local display: HOME → BASIC FUNCTION → PROCESS PARAMETER → CONFIGURATION → ON VALUE LF CUT OFF
Measured-value reading on display, even though measuring tube is empty.	<ol style="list-style-type: none"> Perform empty pipe/full pipe adjustment and then switch on empty pipe detection →  73. Fill the measuring tube.
The fault cannot be rectified or some other fault not described above has arisen. In these instances, please contact your Endress+Hauser service organization.	The following options are available for tackling problems of this nature: <ul style="list-style-type: none"> Request the services of an Endress+Hauser service technician If you contact our service organization to have a service technician sent out, please be ready to quote the following information: <ul style="list-style-type: none"> Brief description of the fault Nameplate specifications: order code and serial number →  6 Returning devices to Endress+Hauser The necessary procedures must be carried out before you return a flowmeter requiring repair or calibration to Endress+Hauser →  96. Always enclose a duly completed "Declaration of Contamination" form with the flowmeter. You will find a preprinted "Declaration of Contamination" form at the back of this manual. Replace transmitter electronics Components in the measuring electronics defective → Order spare parts →  90

9.4 Spare parts

You will find detailed troubleshooting instructions in the preceding sections → 79. The measuring device, moreover, provides additional support in the form of continuous self-diagnosis and error messages.

Fault rectification can entail replacing defective components with tested spare parts. The illustration below shows the available scope of spare parts.



Note!

You can order spare parts directly from your Endress+Hauser service organization by providing the serial number printed on the transmitter nameplate. → 6.

Spare parts are shipped as sets comprising the following parts:

- Spare part
- Additional parts, small items (screws, etc.)
- Mounting instructions
- Packaging

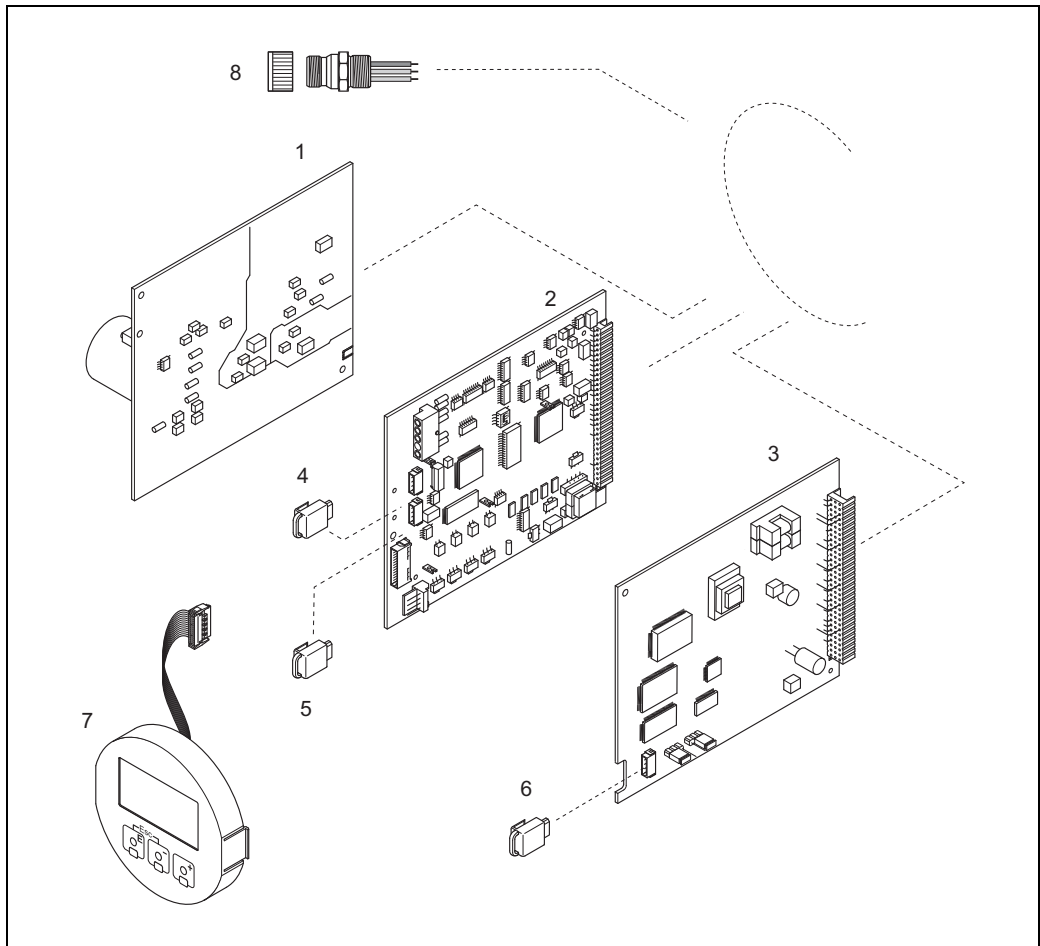

a0006392

Fig. 48: Spare parts for Promag transmitter (field and wall-mount housing)

- 1 Power unit board
- 2 Amplifier board
- 3 I/O board (FOUNDATION Fieldbus type)
- 4 S-DAT (sensor data storage device)
- 5 T-DAT (transmitter data storage device)
- 6 F-CHIP (function chip for optional software)
- 7 Display module
- 8 Fieldbus connectors consisting of connector and protection cap

9.4.1 Removing and installing electronics boards

Field housing



Warning!

- Risk of electric shock. Exposed components carry dangerous voltages. Make sure that the power supply is switched off before you remove the cover of the electronics compartment.
- Risk of damaging electronic components (ESD protection). Static electricity can damage electronic components or impair their operability. Use a workplace with a grounded working surface purpose-built for electrostatically sensitive devices!
- If you cannot guarantee that the dielectric strength of the device is maintained in the following steps, then an appropriate inspection must be carried out in accordance with the manufacturer's specifications.



Caution!

Use only original Endress+Hauser parts.

Installing and removing the boards →  49:

1. Unscrew cover of the electronics compartment from the transmitter housing.
2. Remove the local display (1) as follows:
 - Press in the latches (1.1) at the side and remove the display module.
 - Disconnect the ribbon cable (1.2) of the display module from the amplifier board.
3. Remove the screws and remove the cover (2) from the electronics compartment.
4. Remove power unit board (4) and I/O board (6):
Insert a thin pin into the hole provided (3) and pull the board clear of its holder.
5. Remove amplifier board (5):
 - Disconnect the plug of the electrode cable (5.1) including S-DAT (5.3) from the board.
 - Loosen the plug locking of the coil current cable (5.2) and gently disconnect the plug from the board, i.e. without moving it to and fro.
 - Insert a thin pin into the hole provided (3) and pull the board clear of its holder.
6. Installation is the reverse of the removal procedure.

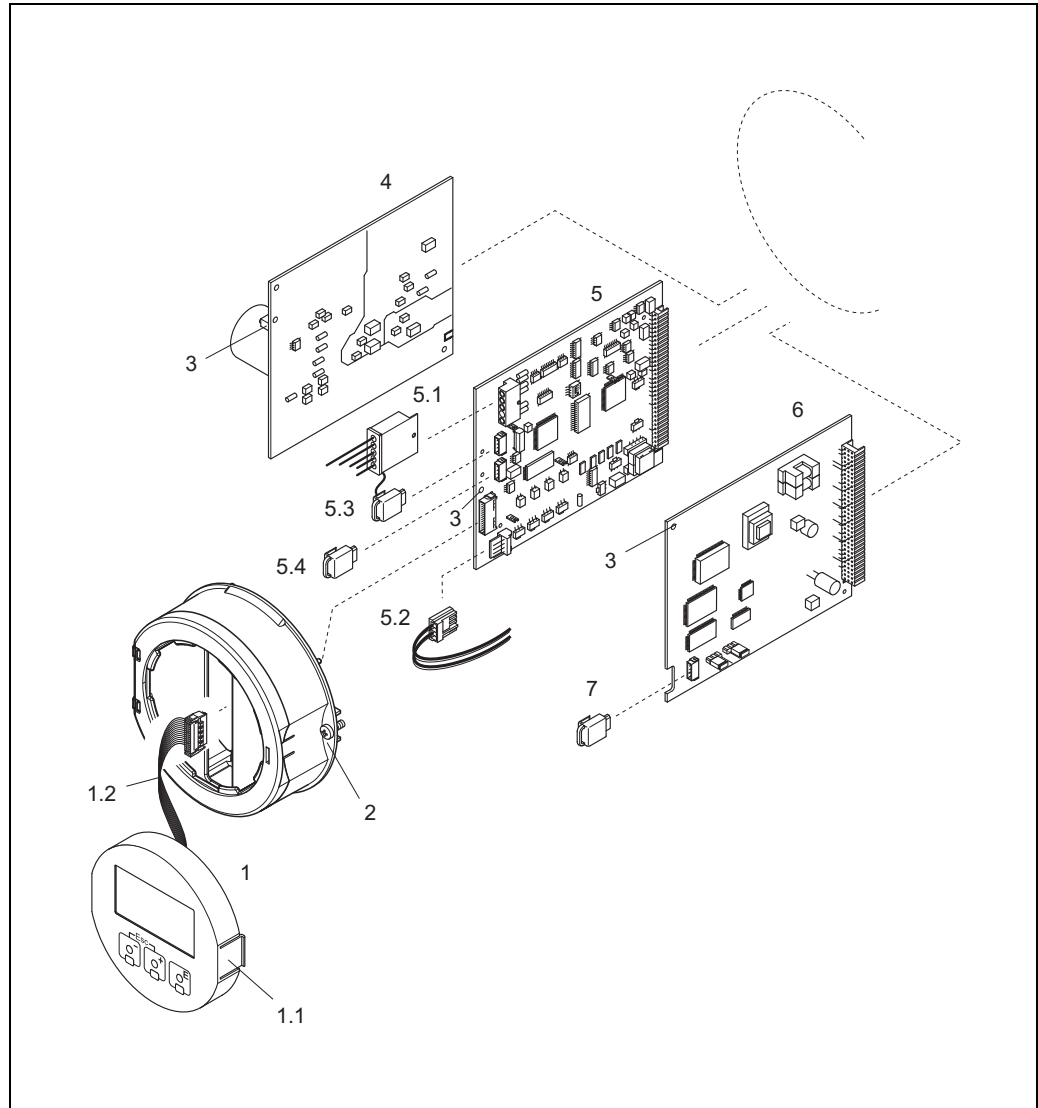

Fig. 49: Field housing: removing and installing electronics boards

- 1 Local display
- 1.1 Latch
- 1.2 Ribbon cable (display module)
- 2 Screws for electronics compartment cover
- 3 Aperture for installing /removing boards
- 4 Power unit board
- 5 Amplifier board
- 5.1 Electrode cable (sensor)
- 5.2 Coil current cable (sensor)
- 5.3 S-DAT (sensor data storage device)
- 5.4 T-DAT (transmitter data storage device)
- 6 I/O board (FOUNDATION Fieldbus type)
- 7 F-CHIP (function chip for optional software)

Wall-mount housing



Warning!

- Risk of electric shock. Exposed components carry dangerous voltages. Make sure that the power supply is switched off before you remove the cover of the electronics compartment.
- Risk of damaging electronic components (ESD protection). Static electricity can damage electronic components or impair their operability. Use a workplace with a grounded working surface purpose-built for electrostatically sensitive devices!
- If you cannot guarantee that the dielectric strength of the device is maintained in the following steps, then an appropriate inspection must be carried out in accordance with the manufacturer's specifications.



Caution!

Use only original Endress+Hauser parts.

Installing and removing the boards →  50:

1. Remove the screws and open the hinged cover (1) of the housing.
2. Loosen the screws securing the electronics module (2). Then push up electronics module and pull it as far as possible out of the wall-mount housing.
3. Disconnect the following cable plugs from amplifier board (7):
 - Electrode cable plug (7.1) including S-DAT (7.3)
 - Plug of coil current cable (7.2): To do so, loosen the plug locking of the coil current cable (7.2) and carefully disconnect the plug from the board, i.e. without moving it to and fro.
 - Ribbon cable plug (3) of the display module
4. Remove the cover (4) from the electronics compartment by loosening the screws.
5. Removing boards (6, 7, 8):
Insert a thin pin into the hole provided (5) and pull the board clear of its holder.
6. Installation is the reverse of the removal procedure.

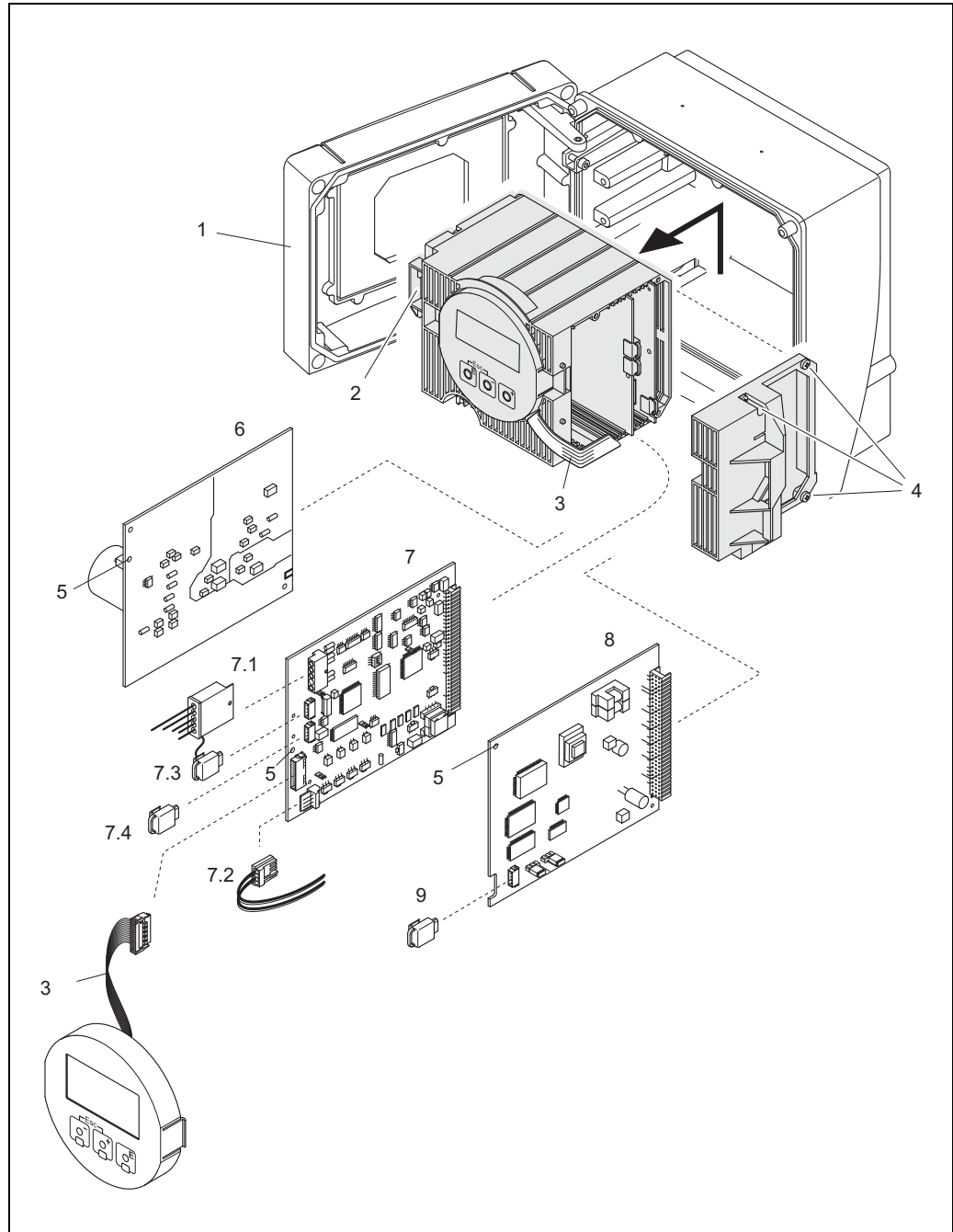

a0006394

Fig. 50: Wall-mount housing: removing and installing electronics boards

- 1 Housing cover
- 2 Electronics module
- 3 Ribbon cable (display module)
- 4 Screws for electronics compartment cover
- 5 Aperture for installing /removing boards
- 6 Power unit board
- 7 Amplifier board
- 7.1 Electrode cable (sensor)
- 7.2 Coil current cable (sensor)
- 7.3 S-DAT (sensor data storage device)
- 7.4 T-DAT (transmitter data storage device)
- 8 I/O board (FOUNDATION Fieldbus type)
- 9 F-CHIP (function chip for optional software)

9.4.2 Replacing the device fuse



Warning!

Risk of electric shock. Exposed components carry dangerous voltages. Make sure that the power supply is switched off before you remove the cover of the electronics compartment.

The main fuse is on the power supply board → 51.

The procedure for replacing the fuse is as follows:

1. Switch off power supply.
2. Remove power unit board → 91.
3. Remove cap (1) and replace the device fuse (2).
Use only fuses of the following type:
 - 20 to 260 V AC / 20 to 64 V DC → 2.0 A slow-blow / 250 V; 5.2 × 20 mm
 - Ex-rated devices → See the Ex documentation
4. Installation is the reverse of the removal procedure.



Caution!

Use only original Endress+Hauser parts.

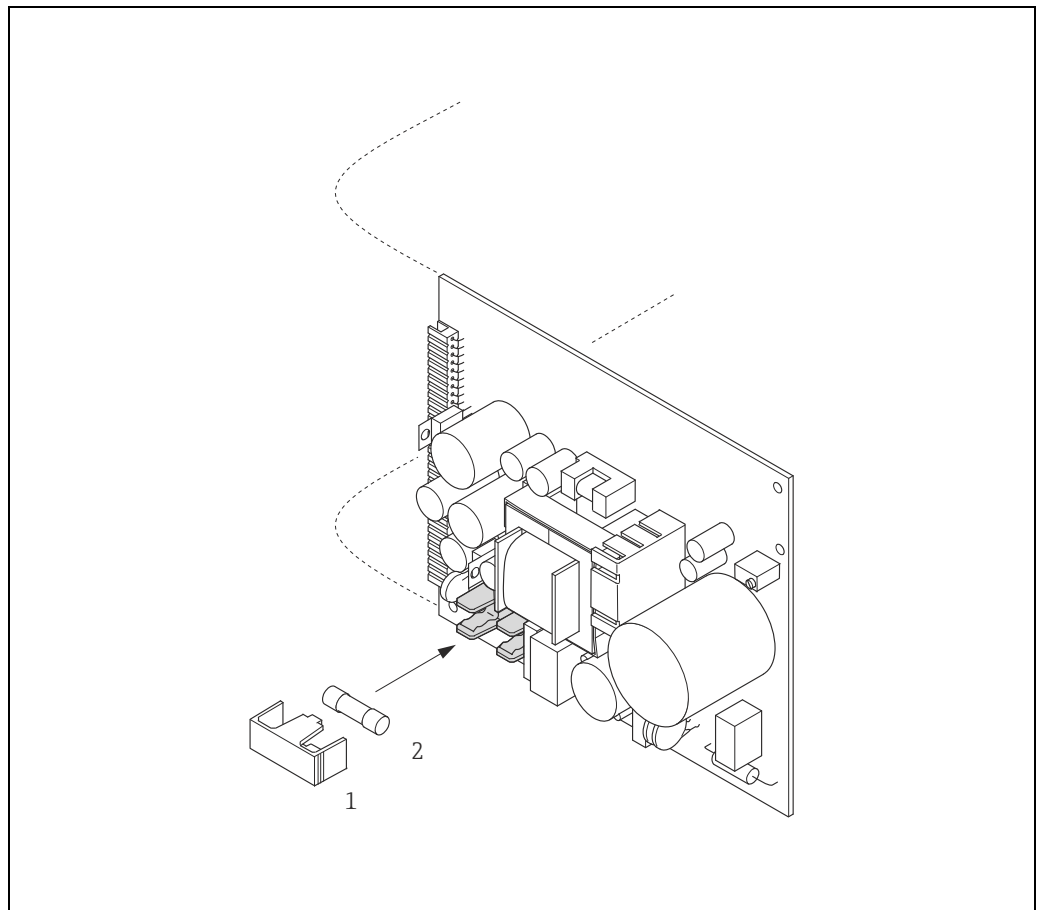

Fig. 51: Replacing the device fuse on the power supply board

- 1 Protection cap
2 Device fuse

9.5 Return

The measuring device must be returned if repairs or a factory calibration are required, or if the wrong measuring device has been ordered or delivered. According to legal regulations, Endress+Hauser, as an ISO-certified company, is required to follow certain procedures when handling returned products that are in contact with medium.

To ensure swift, safe and professional device returns, please read the return procedures and conditions on the Endress+Hauser website at www.services.endress.com/return-material

9.6 Disposal

Please observe the regulations applicable in your country or region.

9.7 Software history

Date	Software-Version	Changes to software	Documentation
11.2014	4.00.XX	-	71749055/14.25
10.2009	3.00.XX	Introduction of new FOUNDATION Fieldbus I/O board Reduced execution times: Analog Input function blocks 1 to 5 (18 ms) PID function block (25 ms) Discrete Output function block (18 ms) Integrator function block (18 ms) Software adjustments: - ITK version: 5.01 - CFF version: 1.8	71089883/07.09
01.2007	2.00.XX	New execution times: <ul style="list-style-type: none"> ▪ Analog Input function blocks 1 to 5 (20 ms) ▪ Discrete Output function block (20 ms) ▪ PID function block (50 ms) New function blocks: <ul style="list-style-type: none"> ▪ Arithmetic function block (20 ms) ▪ Input Selector function block (20 ms) ▪ Signal Characterizer function block (20 ms) ▪ Integrator function block (25 ms) Method: <ul style="list-style-type: none"> ▪ Communication ▪ Commissioning ITK Version: 5.01	71031357/09.06
09.2006	1.01.02	Original software	71031357/09.06

10 Technical data

10.1 Application

→  4

10.2 Function and system design

Measuring principle Electromagnetic flow measurement on the basis of Faraday's Law.

Measuring system →  6

10.3 Input

Measured variable

- Flow rate (proportional to induced voltage)
- Conductivity (without temperature compensation)

Measuring range

- Flow rate: Typical $v = 0.01$ to 10 m/s (0.03 to 33 ft/s) with the specified measuring accuracy
- Conductivity $s = 5$ to 2000 mS/cm
not for sensors without reference electrode (Promag H, Promag S with brush electrodes)

Operable flow range Flow rate: Over 1000 : 1

10.4 Output

Output signal Physical data transmission (Physical Layer Type):

- Fieldbus interface in accordance with IEC 61158-2
- Corresponds to device version type 112 of the FOUNDATION Fieldbus specification: type 112 standard data transfer (± 9 mA, symmetrical), separate supply to field device (4-wire), intrinsically safe version of the FF interface
- With integrated reverse polarity protection

Signal on alarm Status messages as per FOUNDATION Fieldbus specification

Link Master (LM) support Yes

Link Master (factory setting)/Basic Device can be selected Yes

Device basic current 12 mA

Device starting current < 12 mA

Device error current (FDE) 0 mA

Device (lift off) min. voltage 9 V (H1 segment)

Permissible fieldbus supply voltage 9 to 32 V

Integrated reverse polarity protection Yes

ITK Version 5.01

Number of VCRs (total) 38

Number of link objects in VFD 40

Galvanic isolation All circuits for inputs, outputs and power supply are galvanically isolated from each other.

Data transmission rate 31.25 kbit/s, voltage mode

Bus times Min. idle time between two telegrams:
MIN_INTER_PDU_DELAY = 6 octet time (transfer time per octet)

Block information, execution times

Block	Base index	Execution time [ms]	Functionality
Resource Block	400	-	Enhanced
"Flow" Transducer Block	1400	-	Vendor specific
"Diagnosis" Transducer Block	1600	-	Vendor specific
"Display" Transducer Block	1800	-	Vendor specific
"Totalizer" Transducer Block	1900	-	Vendor specific
"Solids Content Flow" Transducer Block	2400	-	Vendor specific
"Advanced Diagnostics" Transducer Block	2500	-	Vendor specific
Analog Input function block 1	500	18	Standard
Analog Input function block 2	550	18	Standard
Analog Input function block 3	600	18	Standard
Analog Input function block 4	650	18	Standard
Analog Input function block 5	700	18	Standard
Analog Output function block (AO)	2300	18	Standard
Discrete Output function block (DO)	850	18	Standard
PID function block (PID)	900	25	Standard
Arithmetic function block (ARTH)	1000	20	Standard
Input Selector function block (ISEL)	1050	20	Standard
Signal Characterizer function block (CHAR)	1100	20	Standard
Integrator function block (INTG)	1150	18	Standard

Output data

Transducer Blocks/Analog Input function blocks

Block	Process variable	Channel parameter (AI Block)
"Flow" Transducer Block	Calculated mass flow	1
	Volume flow	2
"Totalizer" Transducer Block	Totalizer 1	7
	Totalizer 2	8
	Totalizer 3	9

Input data



Discrete Output function block (channel 16)

Status change	Action
Discrete state 0 → Discrete state 1	reserved
Discrete state 0 → Discrete state 2	Positive zero return "ON"
Discrete state 0 → Discrete state 3	Positive zero return "OFF"
Discrete state 0 → Discrete state 4	reserved
Discrete state 0 → Discrete state 5	reserved
Discrete state 0 → Discrete state 6	reserved
Discrete state 0 → Discrete state 7	Reset Totalizer 1, 2, 3
Discrete state 0 → Discrete state 8	Reset Totalizer 1
Discrete state 0 → Discrete state 9	Reset Totalizer 2
Discrete state 0 → Discrete state 10	Reset Totalizer 3
Discrete state 0 → Discrete state 27	Permanent Storage "OFF"
Discrete state 0 → Discrete state 28	Permanent Storage "ON"

VCRs

VCRs (total 48)	48
Permanent Entries	1
Client VCRs	0
Server VCRs	24
Source VCRs	23
Sink VCRs	0
Subscriber VCRs	23
Publisher VCRs	23

10.5 Power supply

Terminal assignment→  38, →  43**Supply voltage**20 to 260 V AC, 45 to 65 Hz
20 to 64 V DC**Power consumption**AC: <45 VA at 260 V AC; <32 VA at 110 V AC (incl. sensor)
DC: <19 W (including sensor)

Switch-on current:

- Max. 2.5 A (< 200 ms) at 24 V DC
- Max. 2.5 A (<5 ms) at 110 V AC
- Max. 5.5 A (<5 ms) at 260 V AC

Power supply failure

Lasting min. 1 power cycle:

- EEPROM or HistoROM/T-DAT saves measuring system data if power supply fails
- HistoROM/S-DAT: exchangeable data storage device which stores sensor characteristic data (nominal diameter, serial number, calibration factor, zero point etc.)

Potential equalization

→  46

Cable entries

Power supply and electrode cable (inputs/outputs):

- Cable gland M20 × 1.5 (8 to 12 mm / 0.31 to 0.47 inch)
- Cable gland sensor for armored cables M20 × 1.5 (9.5 to 16 mm / 0.37 to 0.63 inch)
- Cable entries for thread ½" NPT, G ½"

Connecting cable for remote version:

- Cable gland M20 × 1.5 (8 to 12 mm / 0.31 to 0.47 inch)
- Cable gland sensor for armored cables M20 × 1.5 (9.5 to 16 mm / 0.37 to 0.63 inch)
- Cable entries for thread ½" NPT, G ½"

Cable specifications (remote version)

→  42

10.6 Performance characteristics

Reference operating conditions

- Error limits following DIN EN 29104, future ISO 20456
- Water, typically +15 to +45°C (+59 to +113 °F); 0.5 to 7 bar (73 to 101 psi)
- Specification as per calibration protocol
- Data on the measured error based on accredited calibration rigs traced back to ISO 17025

Maximum measured error

Volume flow

Pulse output:

- Standard: ±0.2% o.r. ± 2 mm/s (o.r. = of reading)
- With option brush electrodes: ±0.5% o.r. ± 2 mm/s (o.r. = of reading)

Current output:

in addition typically ± 5 µA



Note!

Supply-voltage fluctuations have no effect within the specified range.

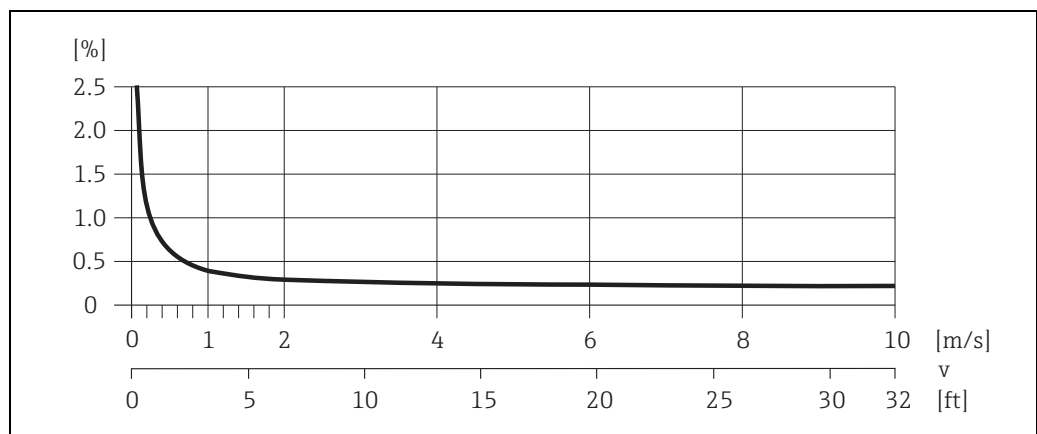

Fig. 52: Max. measured error in % of reading

a0004456

Conductivity

- Max. measuring error not specified
- Without temperature compensation

Repeatability**Volume flow**

- Standard: max. $\pm 0.1\%$ o.r. ± 0.5 mm/s (o.r. = of reading)
- With brush electrodes (Option): max. $\pm 0.2\%$ o.r. ± 0.5 mm/s (o.r. = of reading)

Conductivity

- Max. $\pm 5\%$ o.r. (o.r. = of reading)

10.7 Installation

Installation instructions→  12**Inlet and outlet runs**

Inlet run: typically $\geq 5 \times \text{DN}$
 Outlet run: typically $\geq 2 \times \text{DN}$

Length of connecting cable

The permissible cable length L_{max} for the remote version depends on the conductivity of the medium →  18

10.8 Environment

Ambient temperature range

Transmitter:

- Standard:
 - Compact version: -20 to $+50$ °C (-4 to $+122$ °F)
 - Remote version: -20 to $+60$ °C (-4 to $+140$ °F)
- Optional:
 - Compact version: -40 to $+50$ °C (-40 to $+122$ °F)
 - Remote version: -40 to $+60$ °C (-40 to $+140$ °F)



Note!

At ambient temperatures below -20 °C (-4 °F), the readability of the display may be impaired.

Sensor:

- Flange material carbon steel: -10 to $+60$ °C ($+14$ to $+140$ °F)
- Flange material stainless steel: -40 to $+60$ °C (-40 to $+140$ °F)



Caution!

Do not exceed the min. and max. temperatures for the lining of the measuring tube (→ "Medium temperature range").

Note the following points:

- Install the device at a shady location. Avoid direct sunlight, particularly in warm climatic regions.
- If both fluid and ambient temperatures are high, install the transmitter at a remote location from the sensor (→ "Medium temperature range").

Storage temperature

The storage temperature corresponds to the operating temperature range of the transmitter and sensor.

Degree of protection**Transmitter**

- As standard: IP 67, type 4X enclosure

Sensor

- As standard: IP 67, type 4X enclosure
- Optionally available for remote version for Promag S:
 - IP 68, type 6P enclosure

Shock and vibration resistance

Acceleration up to 2 g in accordance with IEC 600 68-2-6
(High-temperature version: no data available)

Interior cleaning



Caution!
The maximum fluid temperature permitted for the measuring device must not be exceeded.

CIP cleaning possible:

Promag S (with PFA), Promag H

CIP cleaning not possible:

Promag S (with PU, PTFE, hard rubber, natural rubber)

SIP cleaning possible:

Promag S (with PFA), Promag H

SIP cleaning not possible:

Promag S (with PU, PTFE, hard rubber, natural rubber)

Electromagnetic compatibility (EMC)

According to IEC/EN 61326 and NAMUR recommendation NE 21

10.9 Process

Medium temperature range

The permitted temperature depends on the lining of the measuring tube:

Promag S

- 0 to +80 °C (+32 to +176 °F) for hard rubber (DN 65 to 600 / 2½ to 24")
- 0 to +60 °C (+32 to +140 °F) for natural rubber (DN 65 to 600 / 2½ to 24")
- -20 to +50 °C (-4 to +122 °F) for polyurethane (DN 25 to 600 / 1 to 40")
- -20 to +180 °C (-4 to +356 °F) for PFA (DN 25 to 200 / 1 to 8"),
restrictions → see diagrams
- -40 to +130 °C (-40 to +266 °F) for PTFE (DN 15 to 600 / ½ to 24"),
restrictions → see diagrams

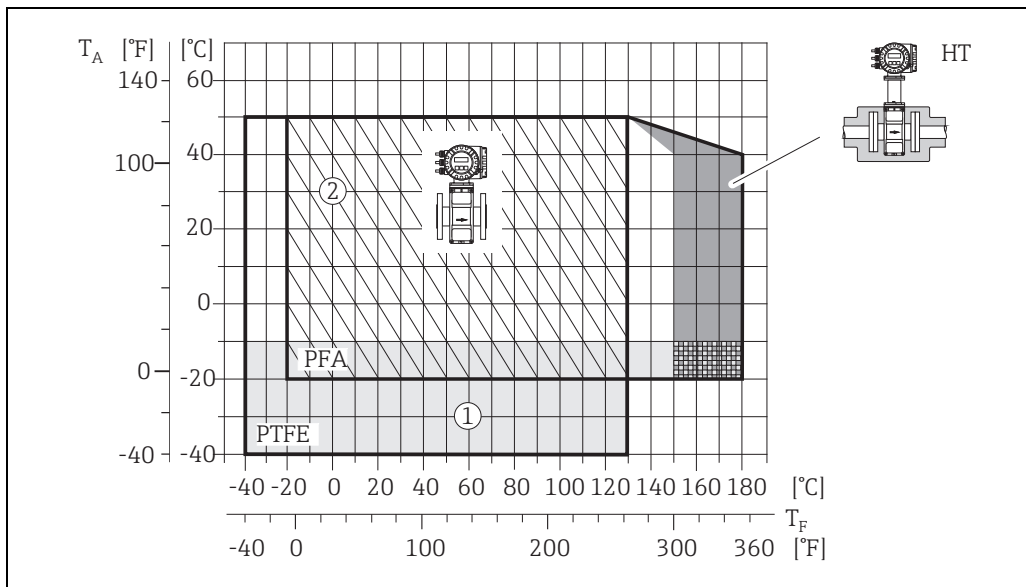

Fig. 53: Compact versions of Promag S (with PFA or PTFE lining)

T_A = ambient temperature; T_F = fluid temperature; HT = high-temperature version with insulation

1 = Light gray area \rightarrow Temperature range from -10 to 40 $^{\circ}\text{C}$ (-14 to -40 $^{\circ}\text{F}$) applies only to stainless steel flanges

2 = Diagonally hatched area \rightarrow foam lining (HE) + degree of protection IP68 = fluid temperature max. 130 $^{\circ}\text{C}$

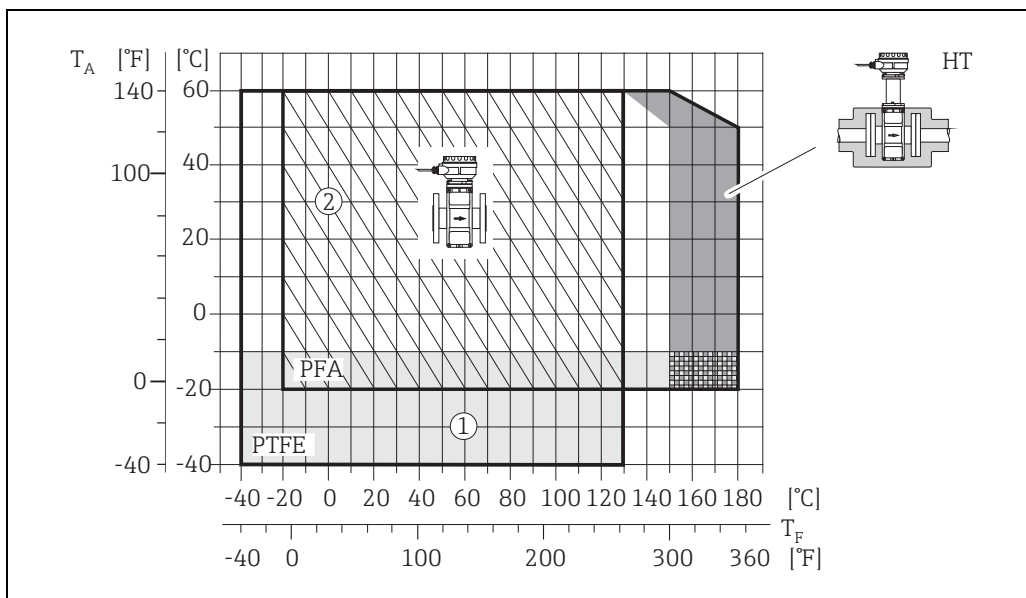

Fig. 54: Remote versions (with PFA or PTFE lining)

T_A = ambient temperature; T_F = fluid temperature; HT = high-temperature version with insulation

1 = Light gray area \rightarrow Temperature range from -10 to 40 $^{\circ}\text{C}$ (-14 to -40 $^{\circ}\text{F}$) applies only to stainless steel flanges

2 = Diagonally hatched area \rightarrow foam lining (HE) + degree of protection IP68 = fluid temperature max. 130 $^{\circ}\text{C}$

Promag H

Sensor:

- DN 2 to 25: -20 to +150 $^{\circ}\text{C}$ (-4 to +302 $^{\circ}\text{F}$)
- DN 40 to 100: -20 to +150 $^{\circ}\text{C}$ (-4 to +302 $^{\circ}\text{F}$)

Seals:

- EPDM: -20 to +150 $^{\circ}\text{C}$ (-4 to +302 $^{\circ}\text{F}$)
- Silicone: -20 to +150 $^{\circ}\text{C}$ (-4 to +302 $^{\circ}\text{F}$)
- Viton: -20 to +150 $^{\circ}\text{C}$ (-4 to +302 $^{\circ}\text{F}$)
- Kalrez: -20 to +150 $^{\circ}\text{C}$ (-4 to +302 $^{\circ}\text{F}$)

Conductivity

The minimum conductivity is:
 ■ $\geq 5 \mu\text{S}/\text{cm}$ for fluids in general



Note!
 In the remote version, the required minimum conductivity is also influenced by the length of the cable → 18.

Pressure-temperature ratings

An overview of the pressure-temperature ratings for the process connections are to be found in the "Technical Information" documents of the device in question.
 List of supplementary documentation → 112 section.

Limiting medium pressure range (nominal pressure)

Promag S sensor

- EN 1092-1 (DIN 2501): PN 10 (DN 200 to 600 / 8 to 24"), PN 16 (DN 65 to 600 / 2½ to 24"), PN 25 (DN 200 to 600 / 8 to 24"), PN 40 (DN 15 to 150 / ½ to 6")
- ASME B 16.5: Class 150 (DN ½ to 24"), Class 300 (DN ½ to 6")
- JIS B2220: 10 K (DN 50 to 600 / 2 to 24"), 20 K (DN 15 to 600 / ½ to 24")
- AS 2129: Table E (DN 25/1", DN 50/2")
- AS 4087: Cl. 14 (DN 50/2")

Promag H

The permissible nominal pressure depends on the process connection, the seal and the nominal diameter.

Details are provided in the separate documentation "Technical Information" → 112.

Pressure tightness (measuring tube lining)

Pressure tightness Promag S in SI units [mbar]

Nominal diameter [mm]	Measuring tube lining	Resistance of measuring tube lining to partial vacuum (SI units) Limit values for abs. pressure [mbar] at various fluid temperatures						
		25 °C	50 °C	80 °C	100 °C	130 °C	150 °C	180 °C
25 to 600	Polyurethane	0	0	-	-	-	-	-
65 to 600	Natural rubber	0	0	-	-	-	-	-
65 to 600	Hard rubber	0	0	0	-	-	-	-

Nominal diameter [mm]	Measuring tube lining	Resistance of measuring tube lining to partial vacuum (SI units) Limit values for abs. pressure [mbar] at various fluid temperatures					
		25 °C	80 °C	100 °C	130 °C	150 °C	180 °C
15	PTFE	0	0	0	100	-	-
25	PTFE / PFA	0/0	0/0	0/0	100/0	-/0	-/0
32	PTFE / PFA	0/0	0/0	0/0	100/0	-/0	-/0
40	PTFE / PFA	0/0	0/0	0/0	100/0	-/0	-/0
50	PTFE / PFA	0/0	0/0	0/0	100/0	-/0	-/0
65	PTFE / PFA	0/0	*	40/0	130/0	-/0	-/0
80	PTFE / PFA	0/0	*	40/0	130/0	-/0	-/0
100	PTFE / PFA	0/0	*	135/0	170/0	-/0	-/0
125	PTFE / PFA	135/0	*	240/0	385/0	-/0	-/0
150	PTFE / PFA	135/0	*	240/0	385/0	-/0	-/0
200	PTFE / PFA	200/0	*	290/0	410/0	-/0	-/0
250	PTFE	330	*	400	530	-	-
300	PTFE	400	*	500	630	-	-
350	PTFE	470	*	600	730	-	-

400	PTFE	540	*	670	800	-	-
450	PTFE	Partial vacuum is impermissible					
500	PTFE						
600	PTFE						
* No value can be quoted.							

Pressure tightness Promag S in US units [psia = pounds/inch²]

Nominal diameter [inch]	Measuring tube lining	Resistance of measuring tube lining to partial vacuum (US units) Limit values for abs. pressure [psia] at various fluid temperatures						
		77 °F	122 °F	176 °F	212 °F	266 °F	302 °F	356 °F
1 to 24"	Polyurethane	0	0	-	-	-	-	-
3 to 24"	Natural rubber	0	0	-	-	-	-	-
3 to 24"	Hard rubber	0	0	0	-	-	-	-

Nominal diameter [inch]	Measuring tube lining	Resistance of measuring tube lining to partial vacuum (US units) Limit values for abs. pressure [psia] at various fluid temperatures					
		77 °F	176 °F	212 °F	266 °F	302 °F	356 °F
½"	PTFE	0	0	0	1.5	-	-
1"	PTFE / PFA	0/0	0/0	0/0	1.5/0	-/0	-/0
-	PTFE / PFA	0/0	0/0	0/0	1.5/0	-/0	-/0
1 ½"	PTFE / PFA	0/0	0/0	0/0	1.5/0	-/0	-/0
2"	PTFE / PFA	0/0	0/0	0/0	1.5/0	-/0	-/0
-	PTFE / PFA	0/0	*	0.6/0	1.9/0	-/0	-/0
3"	PTFE / PFA	0/0	*	0.6/0	1.9/0	-/0	-/0
4"	PTFE / PFA	0/0	*	2.0/0	2.5/0	-/0	-/0
-	PTFE / PFA	2.0/0	*	3.5/0	5.6/0	-/0	-/0
6"	PTFE / PFA	2.0/0	*	3.5/0	5.6/0	-/0	-/0
8"	PTFE / PFA	2.9/0	*	4.2/0	5.9/0	-/0	-/0
10"	PTFE	4.8	*	5.8	7.7	-	-
12"	PTFE	5.8	*	7.3	9.1	-	-
14"	PTFE	6.8	*	8.7	10.6	-	-
16"	PTFE	7.8	*	9.7	11.6	-	-
18"	PTFE	Partial vacuum is impermissible					
20"	PTFE						
24"	PTFE						
* No value can be quoted.							

Pressure tightness Promag H (Measuring tube lining: PFA)

Promag H Nominal diameter		Resistance of measuring tube lining to partial vacuum (US units) Limit values for abs. pressure [psia] at various fluid temperatures					
[mm]	[inch]	25 °C	80 °C	100 °C	130 °C	150 °C	180 °C
		77 °F	176 °F	212 °F	266 °F	302 °F	356 °F
2 to 150	½ ₁₂ to 6"	0	0	0	0	0	0

Limiting flow

Further information can be found in the "Nominal diameter and flow rate" section →  17

Pressure loss

- No pressure loss if the sensor is installed in piping with the same nominal diameter (for Promag H only from DN8).
- Pressure losses for configurations incorporating adapters according to DIN EN 545 →  16.

10.10 Mechanical construction

Design / dimensions

The dimensions and face-to-face length of the sensor and transmitter can be found in the separate "Technical Information" documentation for each device which can be downloaded in PDF format from www.endress.com. A list of available "Technical Information" documentation can be found in the "Documentation" section →  112.

Weight (SI units)



Promag S

Note!

The following weights apply to standard pressure ratings and without packaging material.

Nominal diameter [mm]	Weight in kilograms [kg]								
	Compact version			Remote version (without cable)					
	EN (DIN) / AS*	JIS	Sensor		Transmitter (Wall-mount housing)				
	EN (DIN) / AS*	JIS	EN (DIN) / AS*	JIS					
15	PN 40	6.5	10K 10K	6.5	PN 40	4.5	10K	4.5	6.0
25		7.3		7.3		5.3		5.3	6.0
32		8.0		7.3		6.0		5.3	6.0
40		9.4		8.3		7.4		6.3	6.0
50		10.6		9.3		8.6		7.3	6.0
65	PN 16	12.0	10K 10K	11.1	PN 16	10.0	10K	9.1	6.0
80		14.0		12.5		12.0		10.5	6.0
100		16.0		14.7		14.0		12.7	6.0
125		21.5		21.0		19.5		19.0	6.0
150		25.5		24.5		23.5		22.5	6.0
200	PN 10	45	10K 10K	41.9	PN 10	43	10K	39.9	6.0
250		65		69.4		63		67.4	6.0
300		70		72.3		68		70.3	6.0
350		115		79		113		77	6.0
400		135		100		133		98	6.0
450		175		128		173		126	6.0
500		175		142		173		140	6.0
600		235		188		233		186	6.0

Transmitter (compact version): 3.4 kg
 High-temperature version: +1.5 kg
 * Only DN 25 and 50 are available for flanges according to AS

Promag H



Note!

The following weights apply to standard pressure ratings and without packaging material.

Nominal diameter DIN [mm]	Compact version (DIN)		Remote version (without cable; DIN)	
	Aluminum field housing [kg]	Stainless steel field housing [kg]	Sensor [kg]	Transmitter (wall-mount housing) [kg]
2	5.2	5.7	2.0	6.0
4	5.2	5.7	2.0	6.0
8	5.3	5.8	2.0	6.0
15	5.4	5.9	1.9	6.0
25	5.5	6.0	2.8	6.0
40	7.1	7.6	4.1	6.0
50	7.6	8.1	4.6	6.0
65	8.4	8.9	5.4	6.0
80	9.0	9.5	6.0	6.0
100	10.3	10.8	7.3	6.0
125	15.7	16.2	12.7	6.0
150	18.1	18.6	15.1	6.0

Transmitter (compact version): 3.4 kg

Weight (US units)



Promag S

Note!

The following weights apply to standard pressure ratings and without packaging material.

Nominal diameter [inch]	Weight in pounds [lbs]				
	Compact version		Remote version (without cable)		
	ASME		Sensor ASME	Transmitter (Wall-mount housing)	
1/2"	Class 150	14	Class 150	10	13
1"		16		12	13
1 1/2"		21		16	13
2"		23		19	13
3"		31		26	13
4"		35		31	13
6"		56		52	13
8"		99		95	13
10"		165		161	13
12"		243		238	13
14"		386		381	13
16"		452		448	13
18"		562		558	13
20"		628		624	13
24"		893		889	13

Transmitter (compact version): 7.5 lbs
High-temperature version: +3.3 lbs

Promag H



Note!

The following weights apply to standard pressure ratings and without packaging material.

Nominal diameter DIN [in]	Compact version (DIN)		Remote version (without cable; DIN)	
	Aluminum field housing [lbs]	Stainless steel field housing [lbs]	Sensor [lbs]	Transmitter (wall-mount housing) [lbs]
1/12"	11.5	12.6	4.0	13.0
1/8"	11.5	12.6	4.0	13.0
3/8"	11.7	12.8	4.0	13.0
1/2"	11.9	13.0	4.0	13.0
1"	12.1	13.2	6.0	13.0
1 1/2"	15.7	16.8	4.1	13.0
2"	16.8	17.9	4.6	13.0
3"	19.8	20.9	6.0	13.0
4"	22.7	23.8	7.3	13.0
6"	39.9	41.0	15.1	13.0
Transmitter (compact version): 7.5 lbs				

Material

Promag S

Transmitter housing:

- Compact and remote version: Powder-coated die-cast aluminum
- Window material: glass or polycarbonate

Sensor housing:

- DN 15 to 300 (1/2 to 12"): powder-coated die-cast aluminum
- DN 350 to 600 (14 to 24"): painted steel

Measuring tube:

- DN < 350 (14"): stainless steel 1.4301 or 1.4306 (304L). For flanges made of carbon steel with Al/Zn protective coating.
- DN > 300 (12"): stainless steel 1.4301 (304). For flanges made of carbon steel with protective varnish.

Flanges:

- EN 1092-1 (DIN 2501): EN 1092-1 (DIN 2501): S235JRG2, S2345JR+N, P250GH, P245GH, A105, E250C, 1.4571, F316L (DN < 350/14": with Al/Zn protective coating; DN > 300/12" with protective varnish)
- ASME B16.5: A105, F316L (DN < 350/14" with Al/Zn protective coating; DN > 300/12" with protective varnish))
- JIS B2220: A105, A350 LF2, F316L (DN < 350/14" with Al/Zn protective coating; DN > 300/12" with protective varnish))
- AS 2129: A105, P235GH, P265GH, S235JRG2, E250C, with Al/Zn protective coating
- AS 4087: A105, P265GH, S275JR, E250C, with Al/Zn protective coating

Ground disks: 1.4435 (316L) or Alloy C-22

Electrodes:

- 1.4435, platinum, Alloy C-22, tantalum, titanium Gr. 2, tungsten carbide coating (for electrodes made of 1.4435)
- 1.4310 (302) (for brush electrodes), Duplex 1.4462, Alloy X750 (for brush electrodes)

Seals: according to DIN EN 1514-1 form IBC

Promag H

Transmitter housing:

- Compact housing: Powder-coated die-cast aluminum or stainless steel field housing (1.4301 (316L))
- Wall-mount housing: Powder-coated die-cast aluminum
- Window material: glass or polycarbonate
- Sensor housing: stainless steel 1.4301
- Wall mounting kit (holder panel): stainless steel 1.4301
- Measuring tube: stainless steel 1.4301

Lining material:

- PFA (USP Class VI; FDA 21 CFR 177.1550; 3A)

Flanges:

- Connection generally made of stainless steel 1.4404, F316L
- Flanges (EN (DIN), ASME, JIS) also in PVDF
- Adhesive fitting made of PVC

Electrodes:

- Standard: 1.4435
- Optional: Alloy C-22, tantalum, platinum (only up to DN 25 (1"))

Seals:

- DN 2 to 25: O-ring (EPDM, Viton, Kalrez) or molded seal (EPDM, silicone, Viton)
- DN 40 to 150: molded seal (EPDM, silicone)

Grounding rings:

- Standard: 1.4435 (316L)
- Optional: Alloy C-22, tantalum

Fitted electrodes**Promag S**

Available as standard:

- 2 measuring electrodes for signal detection
- 1 EPD electrode for empty pipe detection
- 1 Reference electrode for potential equalization

Optionally available for measuring electrodes made of platinum:

- 1 EPD electrode for empty pipe detection
- 1 reference electrode for potential equalization

For measuring tube with natural rubber lining in combination with brush electrodes:

- 2 brush electrodes for signal detection

Promag H

- 2 measuring electrodes for signal detection
- 1 EPD electrode for empty pipe detection, not for DN 2 to 8 ($\frac{1}{12}$... $\frac{5}{16}$ ")

Process connection**Promag S**

Flange connection EN 1092-1 (DIN 2501):

- DN < 300: form A
- DN > 300: form B
DN 65 (2½") PN 16 and DN 600 (24") PN 16 exclusively according to EN 1092-1
- ASME
- JIS B2220
- AS 2129
- AS 4087

Promag H

With O-ring:

- Weld nipple DIN (EN), ISO 1127, ODT/SMS
- Flange EN (DIN), ASME, JIS
- Flange made of PVDF EN (DIN), ASME, JIS
- External thread
- Internal thread
- Hose connection
- PVC adhesive fitting

With molded seal:

- Weld nipple EN 10357 (DIN 11850), ODT/SMS
- Clamp ISO 2852, DIN 32676, L14 AM7
- Coupling DIN 11851, DIN 11864-1, ISO 2853, SMS 1145
- Flange DIN 11864-2

Surface roughness

All data relate to wetted parts.

- Liner → PFA: ≤ 0.4 μm (15 μin)
- Electrodes: 0.3 to 0.5 μm (12 to 20 μin)
- Process connection made of stainless-steel (Promag H):
 - With O-ring seal: ≤ 1.6 μm (63 μin)
 - With aseptic gasket seal: ≤ 0.8 μm (31.5 μin)
 - Optional: ≤ 0.38 μm (15 μin)

10.11 Operability

Display elements

- Liquid crystal display: illuminated, four lines with 16 characters per line
- Custom configurations for presenting different measured values and status variables
- 3 totalizers
- At ambient temperatures below -20 °C (-4 °F), the readability of the display may be impaired.

Operating elements

- Onsite operation with three optical sensor keys (☐/☒/☓)
- Application-specific Quick Setup menus for straightforward commissioning

Language packages

Language groups available for operation in different countries:

- Western Europe and America (WEA):
English, German, Spanish, Italian, French, Dutch, Portuguese
- Eastern Europe/Scandinavia (EES):
English, Russian, Polish, Norwegian, Finnish, Swedish, Czech
- South and East Asia (SEA):
English, Japanese, Indonesian
- China (CN):
English, Chinese

10.12 Certificates and approvals

CE approval	The measuring system complies with the legal requirements of the EU directives. Endress+Hauser confirms that the device has been tested successfully by affixing the CE mark to it.
C-tick symbol	The measuring system is in conformity with the EMC requirements of the "Australian Communications and Media Authority (ACMA)".
Ex approval	Information about currently available Ex versions (ATEX, FM, CSA, IECEx, NEPSI etc.) can be supplied by your Endress+Hauser Sales Center on request. All explosion protection data are given in a separate documentation which is available upon request.
Sanitary compatibility	<p>Promag S</p> <p>No applicable approvals or certification</p> <p>Promag H</p> <ul style="list-style-type: none"> ▪ 3A-approval and EHEDG-certified ▪ Seals: FDA-compliant (except for Kalrez seals)
Pressure equipment directive	<p>The devices can be ordered with or without a PED approval. If a device with a PED approval is required, this must be explicitly stated in the order. For devices with nominal diameters less than or equal to DN 25 (1"), this is neither possible nor necessary.</p> <ul style="list-style-type: none"> ▪ With the PED/G1/x (x = category) marking on the sensor nameplate, Endress+Hauser confirms compliance with the "Essential Safety Requirements" specified in Annex I of the Pressure Equipment Directive 2014/68/EU. ▪ Devices bearing this marking (PED) are suitable for the following types of medium: Media in Group 1 and 2 with a vapor pressure greater than, or smaller and equal to 0.5 bar (7.3 psi) ▪ Devices not bearing this marking (PED) are designed and manufactured according to good engineering practice. They meet the requirements of Art.4 Section 3 of the Pressure Equipment Directive 2014/68/EU. The range of application is indicated in tables 6 to 9 in Annex II of the Pressure Equipment Directive 2014/68/EU.
FOUNDATION Fieldbus certification	<p>The flowmeter has passed all the test procedures implemented and has been certified and registered by the Fieldbus Foundation. The device thus meets all the requirements of the following specifications:</p> <ul style="list-style-type: none"> ▪ Certified to FOUNDATION Fieldbus specification ▪ The flowmeter meets all the specifications of the FOUNDATION Fieldbus H1. ▪ Interoperability Test Kit (ITK), revision 5.01: The device can also be operated in conjunction with other-make certified devices. ▪ Physical Layer Conformance Test by Fieldbus Foundation
Other standards and guidelines	<ul style="list-style-type: none"> ▪ EN 60529: Degrees of protection by housing (IP code) ▪ EN 61010-1 Protection measures for electrical equipment for measurement, control, regulation and laboratory procedures ▪ IEC/EN 61326 "Emission in accordance with requirements for class A". Electromagnetic compatibility (EMC requirements). ▪ ANSI/ISA-S82.01

Safety Standard for Electrical and Electronic Test, Measuring, Controlling and related Equipment - General Requirements. Pollution degree 2, Installation Category II.

- CAN/CSA-C22.2 (No. 1010.1-92)
Safety requirements for Electrical Equipment for Measurement and Control and Laboratory Use. Pollution degree 2, Installation Category I.
- NAMUR NE 21
Electromagnetic compatibility (EMC) of industrial process and laboratory control equipment.
- NAMUR NE 43
Standardization of the signal level for the breakdown information of digital transmitters with analog output signal.
- NAMUR NE 53
Software of field devices and signal-processing devices with digital electronics.

10.13 Ordering information

Detailed ordering information is available from the following sources:

- In the Product Configurator on the Endress+Hauser website: www.endress.com → Select country → Instruments → Select device → Product page function: Configure this product
- From your Endress+Hauser Sales Center: www.endress.com/worldwide



Note!

Product Configurator - the tool for individual product configuration

- Up-to-the-minute configuration data
- Depending on the device: Direct input of measuring point-specific information such as measuring range or operating language
- Automatic verification of exclusion criteria
- Automatic creation of the order code and its breakdown in PDF or Excel output format
- Ability to order directly in the Endress+Hauser Online Shop

10.14 Accessories

Various accessories are available for the transmitter and the sensor. These can be ordered separately from Endress+Hauser →  77.



Note!

For detailed information on specific order codes, please contact the Endress+Hauser service organization.

10.15 Documentation

- Flow Measurement (FA00005D/06)
- Promag 55 S Technical Information (TI00071D/06)
- Promag 55 S Technical Information (TI00096D/06)
- Promag 55 Description of Device Functions (BA00127D/06)
- Supplementary documentation on Ex-ratings: ATEX, FM, CSA

Index

A

Accessories	77
Adapters (installation of sensors)	16
Ambient temperature range	101
Applicator (selection and configuration software)	78
Approvals	9

C

Cable entries	
Degree of protection	48
Technical data	100
Cable length (remote version)	18
Cable specifications	
Remote version	42
Cable specifications (remote version)	
Cable length, conductivity	18
Calibration factor	7
CE mark	111
CE mark (Declaration of Conformity)	9
Certificates	9
Change parameter / enter numerical values	54
CIP cleaning	102
Cleaning (exterior cleaning)	76
Code entry (function matrix)	55
Commissioning	
"Commissioning" Quick Setup menu	66
Empty pipe and full pipe adjustment (EPD)	73
Initial operation (FF interface)	61
Commubox FXA193	57
Conductivity of the fluid	
Length of connecting cable (remote version)	18
Connection	
See Electrical connection	
C-tick mark	9, 111

D

Data backup	68
Declaration of Conformity (CE mark)	9
Degree of protection	48
Designated use	4
Device description files	58
Device designation	6, 97
Device functions	
See the "Description of Device Functions" manual	
Display	
Display	52
Display and operating elements	51
Local display	51
See Display	
Turning the display	31
Disposal	96
Documentation, supplementary	112
Down pipes	13
Druckgerätezulassung	111

E

Electrical connection	
-----------------------	--

Cable specification (remote version)	42
Degree of protection	48
Post-connection check (checklist)	49
Potential equalization	46
Terminal assignment, transmitter	45
Transmitter	43, 88
Electrode cleaning circuitry	
See the "Description of Device Functions" manual ...	14
Electrodes	
Electrode Cleaning Circuitry (ECC)	14
EPD electrode	14
Fitted electrodes	109
Measuring electrode plane	14
Reference electrode (potential equalization)	14
Test pulses (detection of buildup)	71
Electromagnetic compatibility (EMC)	42
Electronics boards (installing/removing)	
Field housing	91
Wall-mount housing	93
Empty pipe adjustment	
See Empty Pipe Detection	
Empty pipe detection (EPD)	73
EPD electrode	14
General information	73
Environment	101
EPD	
See Empty Pipe Detection	
Error limits	
See Performance characteristics	
Error messages	
Confirming error messages	56
Process errors (application errors)	88
System errors (device errors)	83
Error types (system and process errors)	56
Europäische Druckgeräterichtlinie	111
Ex approval	111
Exterior cleaning	76

F

F-Chip	75
FieldCare	57
Fieldcheck (tester and simulator)	78
Flow rate (as a function of nominal diameter)	17
FOUNDATION Fieldbus	
Hardware write protection	59
Full pipe adjustment (EPD)	73
Function check	60
Function descriptions	
See the "Description of Device Functions" manual	
Function matrix (operation)	54
Fuse, replacing	95
FXA193	78

G

Galvanic isolation	98
Grounding	37

H	
Hardware write protection	
FOUNDATION Fieldbus	59
High-temperature version	
Installation	26
Temperature ranges	26
HOME position (operating mode display)	51
I	
Incoming acceptance	10
Inlet run	15
Input	97
Installation	
Promag H	27
Wall-mount housing	32
Installation conditions	
Dimensions	29
Down pipes	13
Foundations, supports	16
Inlet and outlet runs	15
Installing pumps	12
Mounting location	12
Nominal diameter and flow rate	17
Orientation (vertical, horizontal)	14
Partially filled pipes	12
Vibrations	15
Installing sensor	
Promag H with weld nipples	29
Installing the sensor	
Adapters	16
Foundations (DN > 300)	16
High-temperature version	26
Insulation of pipes (installing Promag S)	26
J	
Jumpers	59
L	
Language groups	110
Length of connecting cable (remote version)	101
Local display	
See Display	
M	
Maintenance	76
Material	108
Measured variable	97
Measuring accuracy	
Maximum measured error	100
Measuring electrodes	
See Electrodes	
Measuring principle	97
Measuring system	6, 97
Measuring tube	
Lining, resistance to partial vacuum	104
Lining, temperature range	102
Medium pressure range	104
Medium temperature range	102
Mounting the sensor	
See Installing the sensor	
N	
Nameplate	
Connections	8
Sensor	7
Transmitter	6
Nominal pressure	
See Medium pressure range	
O	
Operable flow range	97
Operating conditions	101
Operating elements	51
Operation	
Device description files	58
Display and operating elements	
FieldCare	57
Function matrix	54
Operational safety	4
Order code	
Accessories	77
Sensor	7
Transmitter	6
Outlet runs	15
Output	97
Output signal	97
P	
Post-installation check (checklist)	34
Power consumption	99
Power supply (supply voltage)	99
Power supply failure	100
Pressure loss	
Adapters (reducers, expanders)	16
General information	106
Resistance of measuring tube lining to partial vacuum	104
Pressure-temperature ratings	104
Process connection	109
Process error	
Definition	56
Process error messages	88
Process errors without a message	89
Programming mode	
Disable	55
Enable	55
Promag H	
Installation	27
Pumps	
Mounting location	12
Q	
Quick Setup	
Commissioning	66
Data backup	68
R	
Registered trademarks	9
Replacing	
Device fuse	95
Electronics boards (installing/removing)	91

Resistance of measuring tube lining to partial vacuum	104	Weights	106–107
S		Welding work	
Safety icons	5	grounding welding equipment	29
Safety instructions	4	Promag H with weld nipples	29
Sanitary compatibility	111	Wiring	
Screw tightening torques		See Electrical connection	
for Promag H (with plastic process connections)	27	Write protection	59
S-DAT (HistoROM)	75		
Seals	76		
Promag H	27		
Seals (sensor process connection)	20		
Sensor installation			
See Installing sensor			
Serial number	6–8		
Service interface			
Commubox FXA193	57		
Commubox FXA291	78		
Shielding	37		
Shock resistance	102		
Signal on alarm	97		
Software			
Amplifier display	60		
Versions (History)	96		
Spare parts	90		
Standards, guidelines	111		
Storage	11		
Supply voltage (power supply)	99		
System error			
Definition	56		
System error messages	83		
T			
T-DAT			
Save/load	68		
T-DAT (HistoROM)			
Description	75		
Temperature ranges			
Ambient temperature range	101		
Fluid temperature	102		
Storage temperature	101		
Torques (sensor installation)	21		
Transmitter			
Electrical connection	43		
Installing the wall-mount housing	32		
Length of connecting cable (remote version)	18		
Turning the field housing	30		
Turning the field housing (aluminum)	30		
Turning the field housing (stainless steel)	30		
Transporting the sensor	10		
Troubleshooting instructions	79		
V			
Vibration resistance	102		
Vibrations	15		
Measures to prevent vibrations	15		
Shock and vibration resistance	102		
W			
Wall-mount housing, installing	32		

www.addresses.endress.com
