

MODELS PA1 & PL1

PRESSURE REDUCING SANITARY REGULATORS

SECTION I

I. DESCRIPTION AND SCOPE

Models PA1 and PL1 are pressure reducing regulators used to control downstream (outlet or P_2) pressure. Inlet and outlet size 1/2" (DN15) and 3/4" (DN 20) with Tri-Clamp® connections. Each model incorporates electro-polished stainless steel construction. Refer to Technical Bulletin PA1/PL1-TB for specific design conditions and selection recommendations.

SECTION II

II. INSTALLATION

⚠ CAUTION

Installation of adequate overpressure protection is recommended to protect the regulator and all downstream equipment from damage in the event of regulator failure.

1. An inlet block valve should always be installed upstream of the regulator.
2. If service application is continuous such that shutdown is not readily accomplished, it is recommended that an inlet block valve, outlet block valve, and a manual bypass valve be installed.

⚠ CAUTION

The maximum outlet pressure is listed on the nameplate as the upper range spring pressure level, and is the recommended "upper operative limit" for the sensing diaphragm (see Section IV. Startup, Step 7). Higher pressures could damage the diaphragm. (Field hydrostatic tests frequently destroy diaphragms. DO NOT HYDROSTATIC TEST THROUGH AN INSTALLED UNIT; ISOLATE FROM TEST.)

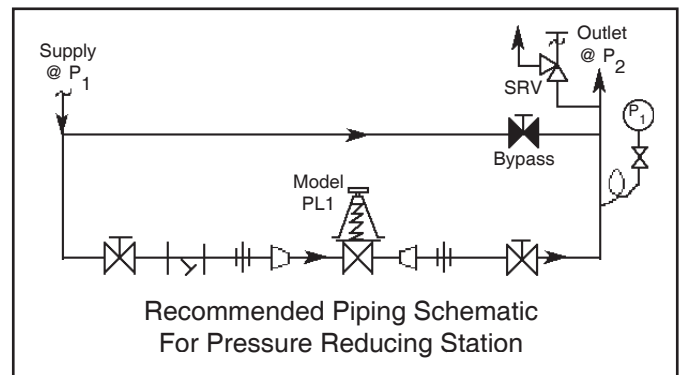

3. An outlet pressure gauge should be located approximately ten pipe diameters downstream, and within sight.
4. All installations should include a downstream relief device if the inlet pressure could exceed the pressure rating of any downstream equipment or the maximum outlet pressure rating of the unit.
5. Flow Direction: Install so the flow direction matches the arrow stamped on the regulator body.
6. Install unit with spring chamber (2) in the vertical position to allow for proper draining.

SECTION III

III. PRINCIPLE OF OPERATION

1. Movement occurs as pressure variations register on the diaphragm. The registering pressure is the outlet, P_2 , or downstream pressure. The range spring opposes diaphragm movement. As

outlet pressure drops, the range spring pushes the diaphragm down, opening the port; as outlet pressure increases, the diaphragm pushes up and the port opening closes.

2. A complete diaphragm failure will cause the regulator to fail open.

SECTION IV

IV. STARTUP

1. For Model PA1: ensure that lock-open pin (19) is not inserted into the hole in the side of the spring chamber. See Section VII.
2. Start with the block valves closed. A bypass valve may be used to maintain outlet pressure in the downstream system without changing the following steps.
3. Relax the range spring by turning the adjusting knob (3) counter clockwise (CCW) a minimum of three full revolutions. This reduces the outlet (downstream) pressure set point.
4. If it is a "hot" piping system and equipped with a bypass valve, slowly open the bypass valve to pre-heat the system piping and to allow slow expansion of the piping. Closely monitor outlet (downstream) pressure via gauge to assure not over-pressurizing. **NOTE:** *If no bypass valve is installed, extra caution should be used in starting up a cold system; i.e. do everything slowly.*
5. Crack open the outlet (downstream) block valve.
6. Slowly open the inlet (upstream) block valve observing the outlet (downstream) pressure gauge. Determine if the regulator is flowing. If not, slowly rotate the regulator's adjusting knob clockwise (CW) until flow begins.

7. Continue to slowly open the inlet (upstream) block valve until fully open.
8. Continue to slowly open the outlet (downstream) block valve, especially when the downstream piping system isn't pressurized. If the outlet (downstream) pressure exceeds the desired pressure, close the block valve and go to Step 3, then return to Step 5.
9. When flow is established steady enough that the outlet (downstream) block valve is fully open, begin to slowly close the bypass valve if installed.
10. Develop system flow to a level near its expected normal rate, and reset the regulator set point by turning the adjusting knob CW to increase outlet pressure, or CCW to reduce outlet pressure.
11. Reduce system flow to a minimum level and observe set point. Outlet pressure will rise from the set point of Step 10. The maximum rise in outlet pressure on decreasing flow should not exceed the stated upper limit of the range spring by greater than 10%; i.e. 20-50 psig (1.4-3.4 Barg) range spring, at low flow the outlet pressure should not exceed 55 psig (3.8 Barg), if it does, consult factory.

SECTION V

V. SHUTDOWN

1. On systems with a bypass valve, and where system pressure is to be maintained as the regulator is shut down, slowly open the bypass valve while closing the inlet (upstream) block valve. Fully close the inlet (upstream) block valve. (When on bypass, the system pressure must be constantly observed and manually regulated. Close the outlet (downstream) block valve.



2. If the regulator and system are to both be shut down, slowly close the inlet (upstream) block valve. Close the outlet (downstream) valve only if regulator removal is required.

SECTION VI

VI. MAINTENANCE



WARNING

SYSTEM UNDER PRESSURE. Prior to performing any maintenance, isolate the regulator from the system and relieve all pressure. Failure to do so could result in personal injury.

A. General:

1. Maintenance procedures hereinafter are based upon removal of the regulator unit from the pipeline where installed.
2. Owner should refer to owner's procedures for removal, handling, cleaning and disposal of nonreusable parts.
3. Refer to Figures 2 and 3 for basic regulator, item number reference ().

B. Maintenance :



WARNING

SPRING UNDER COMPRESSION. Prior to removing spring chamber, relieve spring compression by backing out the adjusting knob. Failure to do so may result in flying parts that could cause personal injury.

1. Secure the body (1) in a soft-jaw vise using the flats on the sides of the body. Orient the knob (3) upwards.
2. Relax compression on spring (8) by turning knob (3) CCW until removed from spring chamber. Not necessary to rotate nut (5). Remove name plate.
3. Loosen spring chamber (2) by placing wrench on flats of spring chamber and rotating CCW making sure not to use flats on either side of vent hole.
4. Remove spring chamber, ball (6), spring button (7) and range spring.
5. With a wrench, secure the flats on the plug (10). Using a 7/16" wrench rotate nut (11) CCW to remove nut and lock washer (12). **Do Not rotate the plug.** See Figure 1. Remove pressure plate (14). **NOTE:** For Model PA1: when nut is removed the plug (10) may slide out through the bottom, inlet connection. Do not let plug fall and damage seat surface.

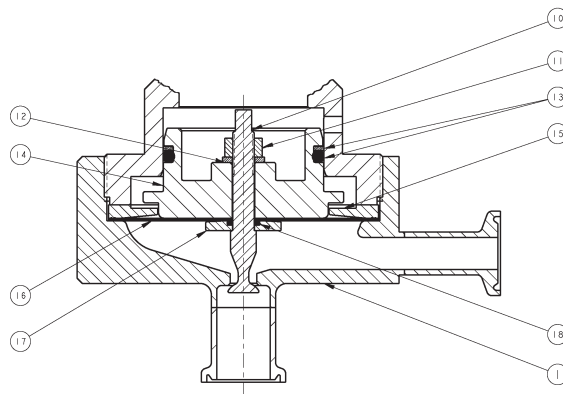

FIGURE 1: Diaphragm & Plug Subassembly

6. Remove stabilizing o-ring with backup ring (13) from groove in O.D. of the pressure plate.
7. Remove travel stop (15), diaphragm (16), o-ring (18) and pusher plate (17).
8. For Model PL1: orient the body in a soft-jaw vise with the body cap (23) upwards. Rotate body cap CCW and remove. Remove o-ring (22). From below, push plug (10) upwards to remove.
9. For Composition Seat Construction: Secure the flats on the small diameter end of the plug in a soft-jaw vise. Use a wrench on the flats of the tail piece and rotate CCW to remove. Remove seat disc (24).
10. Clean body cavity and all reusable parts. **NOTE:** Maintenance must include a level of cleanliness equal to Cashco cleaning standard #S-1576. Contact factory for details.
11. For Composition Seat Construction: Secure the flats on the small diameter end of the plug in a soft-jaw vise. Assemble the seat disc (24) and tail piece (9) on plug. Tighten to approximately 80 in.- oz.
12. For Model PL1: secure the body (1) in a soft-jaw vise using the flats on the side of the body. Orient with smaller, threaded I.D. facing upwards. For Model PA1: the inlet connection is upwards.
13. Insert the plug or plug assembly threaded end first through the body cap opening for Model PL1 or through inlet port for Model PA1.
14. For Model PL1: place o-ring (22) onto the landing above the threads of the body cap

- (23). Lightly apply "Food Grade Anti-Seez" to the body cap threads and install into the body. Tighten to 25-30 ft.-lbs.
15. Re-orient the body in soft jaw vise to where the large body opening faces upward. For Model PA1: hold on to threaded end of plug so it does not fall out of the inlet, bottom connection.
 16. Use appropriate end connection and loading source to pressurize the inlet of the body between 50 and 100 psig. (Inlet pressure will help hold the plug in place during the assembly and assure best plug position for regulation.
 17. Continue to hold the plug (10) while placing the pusher plate (17) over the threaded end of the plug. Be sure to correctly orient the pusher plate so the o-ring groove faces up.
 18. Slide the o-ring (18) over the threaded end of the plug and into the groove of the pusher plate
 19. While still holding the plug, place the diaphragm (16) over the plug down on top of the pusher plate (17). Make sure the diaphragm is lying flat and is centered inside the body.
 20. Place travel stop (15) over the diaphragm, ensure that the grooved side faces the diaphragm.
 21. Lubricate stabilizing o-ring (13) with "Food Grade Anti-Seez" and slide it over the top edge of the pressure plate and into the groove. Position the backup ring (13) above the stabilizing o-ring in the pressure plate groove. Place the pressure plate over the threaded end of the plug.
 22. Place the lock washer (12) over the threaded end of the plug and then thread nut (11) onto the same end of plug.
 23. Using a small adjustable wrench, hold the plug in place by the flats at the top. Use a 7/16" wrench to tighten hex nut to approx. 50 in.- lbs.
 24. Release all pressure that was applied to inlet of the regulator.
 25. Place the range spring (8) on top of the pressure plate. Then place the spring button (7) and ball (6) on top of range spring. Apply a small amount of "Food Grade Anti-Seez" to top of ball.
 26. Lubricate the outside threads and flat bottom surface of spring chamber (2) and threads of adjusting screw (4) with "Food Grade Anti-Seez".
 27. Thread the spring chamber into the body and tighten to 75-100 ft. lbs.
 28. Place the nameplate below the jam nut (5) and thread adjusting screw into the spring chamber until nut (5) makes contact with top of spring chamber.
 29. Use appropriate end connections and test per Cashco Spec #S-1526 for Pressure Reducing Regulators.

NOTE: *Regulators are not tight shutoff devices. Even if pressure builds up beyond set point, a regulator may or may not develop bubble tight shutoff. In general, tighter shutoff can be expected with composition seat.*
 30. For Model PL1: pressurize body with air and spray liquid leak detector to test around body cap (6) and body (1) for leakage. Test pressure should be a minimum of 100 psig (6.9 Barg) at the inlet.
 31. Return to Section IV for start up.

SECTION VII

VII. CLEANING PROCEDURE for MODEL PA1:

A. Pre-Sanitation:

1. Owner should refer to owner's operating procedures for system shutdown to include relieving all system pressure.
2. System internal pressure must be at/near 0 psig (0 Barg). This will ensure plug (17) is fully open. **NOTE: Do not change range spring (8) setting by rotating knob (3).**
3. Insert the lock-open pin (19) into hole in the spring chamber (2). See Figure 2.

B. Sanitation:

1. Flush, drain and sanitize system in accordance to owner's specifications.

NOTE: CIP is limited to 50 psig (3.45 Barg) maximum cleaning solution pressure at 300°F (149°C).

SIP is recommended to 20 psig (1.38 Barg) saturated steam pressure; can withstand 30 psig (2.07 Barg), but may reduce elastomer life expectancy.



CAUTION

Owner's cleaning solution must be compatible with regulator's trim materials.

C. Post-Sanitation:

1. Prior to system start-up, remove the lock-open pin (19) from the spring chamber (2). Unit is again operative at the setpoint established prior to cleaning.

SECTION VIII

VIII. TROUBLE SHOOTING GUIDE

1. Erratic operation; chattering.

Possible Causes	Remedies
A. Oversized regulator; inadequate rangeability.	A1. Check actual flow conditions, re-size regulator for minimum and maximum flow. A2. Increase flow rate. A3. Decrease regulator pressure drop; decrease inlet pressure by placing a throttling orifice in inlet piping union. A4. Install next step higher range spring. Contact factory. A5. Before replacing regulator, contact factory.
B. Worn o-ring; inadequate guiding.	B. Replace stabilizing o-ring (13).

2. Regulator can't pass sufficient flow.

Possible Causes	Remedies
A. Regulator undersized.	A1. Confirm by opening bypass valve together with regulator. A2. Check actual flow conditions, re-size regulator; if regulator has inadequate capacity, consult factory.
B. Incorrect range spring (screwing in CW of adjusting screw does not allow bringing pressure level up to proper level).	B. Replace range spring with proper higher range. Contact factory.
C. Too much droop.	C1. Review droop expected. C2. Contact factory.

3. Leakage through the spring chamber vent hole.

Possible Causes	Remedies
A. Normal-life diaphragm failure.	A. Replace diaphragm.
B. Abnormal short-life diaphragm failure.	B1. Can be caused by excessive chattering. See No. 1. to remedy chatter. B2. Can be caused by corrosive action. Consider alternate diaphragm material. B3. For composition diaphragms, assure not subjecting to over-temperature conditions. B4. Downstream (outlet) pressure buildup occurring that overstresses diaphragms. Relocate regulator or protect with safety relief valve.
C. O-ring failure.	C. Replace O-ring (18), apply appropriate torque.

4. Sluggish operation.

Possible Causes	Remedies
A. Fluid too viscous.	A. Heat fluid. Contact factory.

5. Excessive pressure downstream.

Possible Causes	Remedies
A. Regulator not closing tightly.	A. Inspect the seating. Clean and lap metal seat surfaces; replace if lapping does not remedy. If composition seats are depressed, nicked or embedded with debris, replace trim.
B. Downstream block.	B. Check system; isolate (block) flow at regulator inlet - not outlet. Relocate regulator if necessary.
C. No pressure relief protection.	C. Install safety relief valve, or rupture disc.
D. Restricted diaphragm movement.	D. Assure no moisture in spring chamber at temperatures below freeze point. Assure no dust or debris entering vent opening. If rainwater or debris can enter, re-orient regulator.

SECTION IX

IX. ORDERING INFORMATION

NEW REPLACEMENT UNIT vs PARTS "KIT" FOR FIELD REPAIR

To obtain a quotation or place an order, please retrieve the Serial Number and Product Code that was stamped on the metal name plate and attached to the unit. This information can also be found on the Bill of Material ("BOM") a parts list that was provided when unit was originally shipped. (Serial Number typically 6 digits). Product Code typical format as follows: (last digit is alpha character that reflects revision level for the product).

□□□ - □□□ 7 - □□□□□□□□□□

NEW REPLACEMENT UNIT:

Contact your local Cashco, Inc., Sales Representative with the Serial Number and Product code. With this information they can provide a quotation for a new unit including a complete description, price and availability.

 CAUTION
Do not attempt to alter the original construction of any unit without assistance and approval from the factory. All purposed changes will require a new name plate with appropriate ratings and new product code to accommodate the recommended part(s) changes.

PARTS "KIT" for FIELD REPAIR:

Contact your local Cashco, Inc., Sales Representative with the Serial Number and Product code. Identify the parts and the quantity required to repair the unit from the "BOM" sheet that was provided when unit was originally shipped.

NOTE: *Those part numbers that have a quantity indicated under "Spare Parts" in column "A" reflect minimum parts required for inspection and rebuild, - "Soft Goods Kit". Those in column "B" include minimum trim replacement parts needed plus those "Soft Goods" parts from column "A".*

If the "BOM" is not available, refer to the cross-sectional drawings included in this manual for part identification and selection.

A Local Sales Representative will provide quotation for appropriate Kit Number, Price and Availability.

The contents of this publication are presented for informational purposes only, and while every effort has been made to ensure their accuracy, they are not to be construed as warranties or guarantees, express or implied, regarding the products or services described herein or their use or applicability. We reserve the right to modify or improve the designs or specifications of such product at any time without notice. Cashco, Inc. does not assume responsibility for the selection, use or maintenance of any product. Responsibility for proper selection, use and maintenance of any Cashco, Inc. product remains solely with the purchaser.

FIGURE 2: Basic Model PA1 - showing Metal Seat

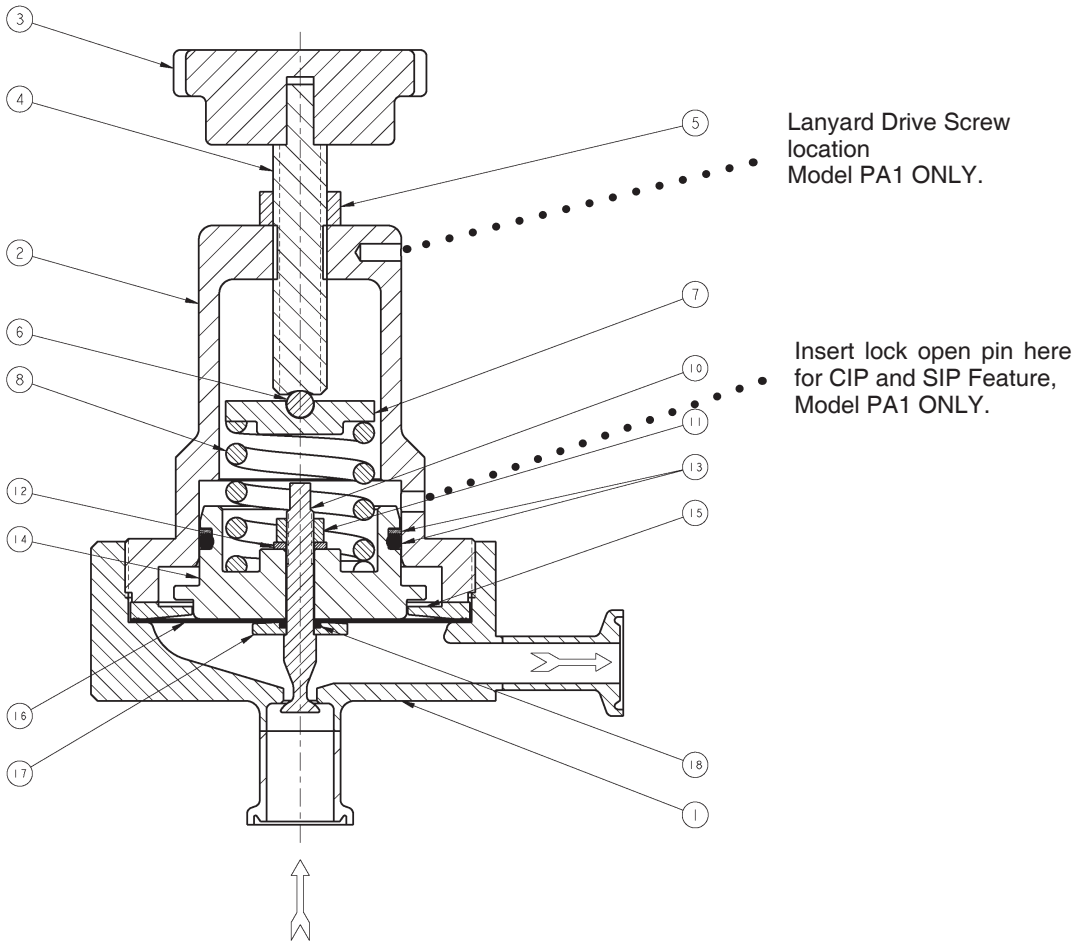
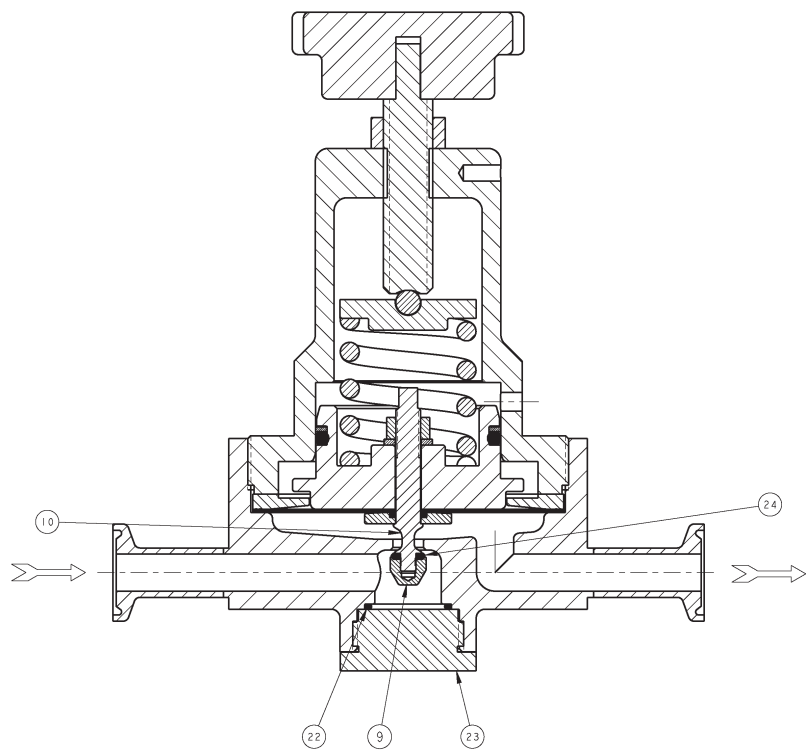

FIGURE 3: Basic Model PL1 - showing Soft Seat



Item No.	Description
1	Body
2	Spring Chamber
3	Knob
4	Adjusting Screw
5	Jam Nut
6	Ball
7	Spring Button
8	Range Spring
9	* Plug Tail Piece
10	Plug
11	Hex Nut (Plug)
12	* Lock Washer (Plug)
13	* Stabilizing O-Ring w/ Backup Ring
14	Pressure Plate
15	Travel Stop
16	* Diaphragm
17	Pusher Plate
18	* O-Ring (Pusher Plate)
19	Pin & Lanyard Assembly (Angle Style Only - Not Shown)
20	Lanyard Drive Screw (Angle Style Only - Not Shown)
21	Name Plate (Not Shown)
22	* O-Ring (Body Cap) (Inline Style Only)
23	Body Cap (Inline Style Only)
24	* Seat Disc

*Recommended replacement part

ATEX 2014/34/EU: Explosive Atmospheres and Cashco Inc. Products



Cashco, Inc. declares that the products listed in the table below has been found to comply with the Essential Health and Safety Requirements relating to the design and construction of products intended for use in potentially explosive atmospheres given in Annex II of the ATEX Directive 2014/34/EU. Compliance with the Essential Health and Safety Requirements has been assured by compliance with EN ISO 80079-36:2016 and EN ISO 80079-37:2016. The product will be marked as follows:

CE  II 2 G
Ex h IIB T6... T1 Gb
1000ATEXR1 X

The 'X' placed after the technical file number indicates that the product is subject to specific conditions of use as follows:

1. The maximum surface temperature depends entirely on the operating conditions and not the equipment itself. The combination of the maximum ambient and the maximum process medium temperature shall be used to determine the maximum surface temperature and corresponding temperature classification, considering the safety margins described prescribed in EN ISO 80079-36:2016, Clause 8.2. Additionally, the system designer and users must take precautions to prevent rapid system pressurization which may raise the surface temperature of system components and tubing due to adiabatic compression of the system gas. Furthermore, the Joule-Thomson effect may cause process gases to rise in temperature as they expand going through a regulator. This could raise the external surface temperature of the regulator body and the downstream piping creating a potential source of ignition. Whether the Joule-Thomson effect leads to heating or cooling of the process gas depends on the process gas and the inlet and outlet pressures. The system designer is responsible for determining whether the process gas temperature may raise under any operating conditions.
2. Where the process medium is a liquid or semi-solid material with a surface resistance in excess of 1GΩ, special precautions shall be taken to ensure the process does not generate electrostatic discharge.
3. Special consideration shall be made regarding the filtration of the process medium if there is a potential for the process medium to contain solid particles. Where particles are present, the process flow shall be <1m/s (<3.3 ft/s) in order to prevent friction between the process medium and internal surfaces.
4. Effective earthing (grounding) of the product shall be ensured during installation.
5. The valve body/housing shall be regularly cleaned to prevent build up of dust deposits.
6. Regulators must be ordered with the non-relieving option (instead of the self-relieving option) if the process gas they are to be used with is hazardous (flammable, toxic, etc.). The self-relieving option vents process gas through the regulator cap directly into the atmosphere while the non-relieving option does not. Using regulators with the self-relieving option in a flammable gas system could create an explosive atmosphere in the vicinity of the regulator.
7. Tied diaphragm regulators with outlet ranges greater than 7 barg (100 psig) should be preset to minimize the risk that improper operation might lead to an outboard leak and a potentially explosive atmosphere.
8. All equipment must only be fitted with manufacturer's original spare parts.
9. Ensure that only non-sparking tools are used, as per EN 1127-1, Annex A.

	PRODUCT
REGULATORS	31-B, 31-N
	1164, 1164(OPT-45)
	1171, 1171(OPT-45), 1171(CRYO)
	2171, 2171(OPT-45), 2171(CRYO), 3171
	1465, 3381, 3381(OPT-45), 3381(OPT-40)
	4381, 4381(OPT-37), 4381(CRYO), 4381(OPT-45), 5381
	MPRV-H, MPRV-L
	PBE, PBE-L, PBE-H
	CA-1, CA-2
	CA1, SA1, CA4, SA4, CA5, SA5
	DA2, DA4, DA5, DA6, DA8
	DA0, DA1, DAP, SAP
	SLR-1, SLR-2, PTR-1
	ALR-1, ULR-1, PGR-1
	BQ, BQ(OPT-45), BQ(CRYO)
	123, 123(CRYO), 123(OPT-45), 123(OPT-46G)
	123-1+6, 123-1+6(OPT-45), 123-1+6(OPT-46G), 123-1+6+S, 123-1+6+S(OPT-40)
	1000HP, 1000HP(OPT-37), 1000HP(OPT-45), 1000HP(OPT-45G), 1000HP(CRYO)
	1000HP-1+6, 1000HP-1+8, 1000LP, 1000LP(OPT-45), 1000LP(OPT-46G)
	6987
	8310HP, 8310HP-1+6, 8310HP-1+8, 8310LP, 8311HP, 8311LP
	345, 345(OPT-45)
	BA1/BL1, PA1/PL1
	C-BPV, C-PRV, C-CS
	D, D(CRYO), D(OPT-37), D(OPT-20), D(OPT-45)
	DL, DL(LCC), DL(OPT-45)
	BR, BR(CRYO)
	HP, HP(LCC), HP(OPT-45), HP(OPT46G), HP-1+6+S(OPT-40), HP-1+6+S
	P1, P2, P3, P4, P5, P7
	B2, B7
	POSR-1, POSR-2
	5200P, 5300P
	135
NW-PL, NW-SO	
CG-PILOT	
FG1	
CONTROL VALVES	RANGER, 987, PREMIER
	964, 521, 988, 988-MB, 989
	2296/2296HF
	SCV-30, SCV-S
	FL800/FL200
TANK BLANKETING	8700, 8910, 8920, 8930, 8940
	2100, 2199
	3100, 3200, 3300, 3400, 3500, 3600, 3700
	1078, 1088, 1100, 1049
	5100, 5200, 5400, 5500
	4100, 4200, 4300, 4400, 4500, 4600
MISC	764P/PD, 764-37, 764T

Cashco, Inc.
P.O. Box 6
Ellsworth, KS 67439-0006
PH (785) 472-4461
Fax. # (785) 472-3539
www.cashco.com
email: sales@cashco.com
Printed in U.S.A. IOM-PA1-PL1

Cashco GmbH
Handwerkerstrasse 15
15366 Hoppegarten, Germany
PH +49 3342 30968 0
Fax. No. +49 3342 30968 29
www.cashco.com
email: germany@cashco.com

Cashco do Brasil, Ltda.
Al.Venus, 340
Indaiatuba - Sao Paulo, Brazil
PH +55 11 99677 7177
Fax. No.
www.cashco.com
email: brazil@cashco.com