

Mark V-100 Series

Control Valve

The Mark V-100 ball valve bodies have excellent Pressure and Flow Control for gasses, various liquids, and fibrous slurries.

The Mark V-100 ball valve design utilizes a standard ball with a triangular shaped wedge formed in it. This design allows for both throttling control and on/off service used in conjunction with a variety of actuators.

The Mark V-100 valve design closes against one of several available ball seals with a shearing action. The Mark V-100 is a flangeless design and allows the valve body to fit between two existing pipeline flanges.

The typical actuator used is the pneumatic spring and diaphragm rotary actuator (1051). Mounting of this actuator can be on the right-hand or left-hand side viewed from the forward flow inlet.

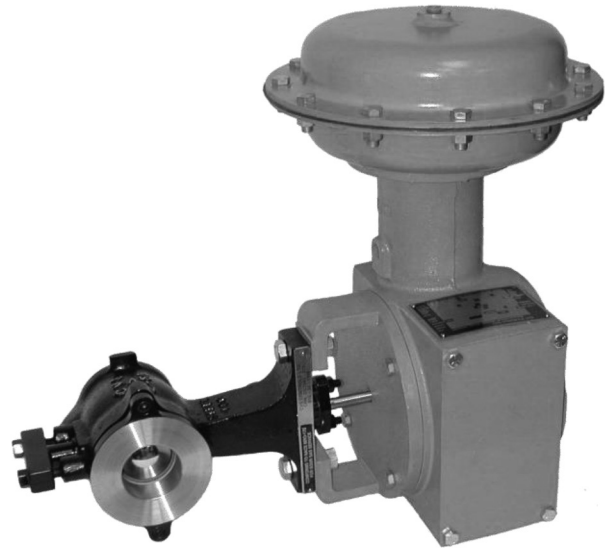

Mark V-100 Valve Body Shown

FEATURES

- Can be used for both throttling and on-off applications
- Flangeless body design fits between raised face flanges
- High flows
- Modified equal percentage flow characteristic
V-ball closes against the ball seal with a shearing action as the ball rotates.
- Used where there are low pressure drops and can be used in slurry applications
- Tight shutoff



Jordan Valve, a division of Richards Industries
3170 Wasson Road • Cincinnati, OH 45209
513.533.5600 • 800.543.7311 • 513.871.0105 (f)
info@richardsind.com • www.jordanvalve.com

SPECIFICATIONS

Sizes: 2"-12"

End Connections:

- ASME 150, 300, & 600 lbs, manufactured to ASME B16.34-latest edition

Body Materials:

- LCC
- WCB
- CF8M SST
- Additional materials may be available upon request

Trim Materials: Ball- CG8M/ Chrome Plated

Seats:

- Metal
- TCM

Shutoff:

Metal Ball Seal:

- 0.001% of valve capacity at full travel: 1/10 of Class IV per ASME/FCI 70-2

TCM Ball Seal:

- 2 ml of air/min/inch of nominal valve size at 50 psi differential (3.4 bar, differential)

Flow Ring:

- 2% of valve capacity at full travel

Maximum Inlet Pressures and Temperatures:

- Consistent with ASME Class 150, 300 and 600 lb pressure/temperature ratings as per ASME B16.34 Refer to the following table and do not exceed the pressure. Refer to "Installation" in the I & M.

Maximum Pressure Drops: Not to exceed pressure drop and temperature conditions specified at the time of ordering

Flow Characteristics: Modified Equal Percentage

Flow Direction:

- Normal (forward) flow is into the convex side of the V-ball
- Bi-directional flow is into either side of the V-Ball; TCM ball seal, metal ball seal, or flow ring

Body Rating and Flange Compatibility

Body Size, Inches	ANSI Rating Class Compatibility (B16.34-latest)	Flange Compatibility	
		ASME Class	DIN PN
2	150, 300, 600	150, 300, 600	10, 16, 25, and 40
3-6	150, 300, 600	150, 300, 600	10, 16, 25, and 40
8	150, 300, 600	150, 300, 600	10, 16 ^a , 25 ^a , and 40 ^a
10	150	150	10 and 16
	300	300	25 and 40
12	150, 300	150, 300	40

a. Special construction required.

MARK V-100 SERIES CONTROL VALVE

DIMENSIONS (INCHES)

Mark 1051 Actuator
and Mark V100 Ball Valve Dimensions

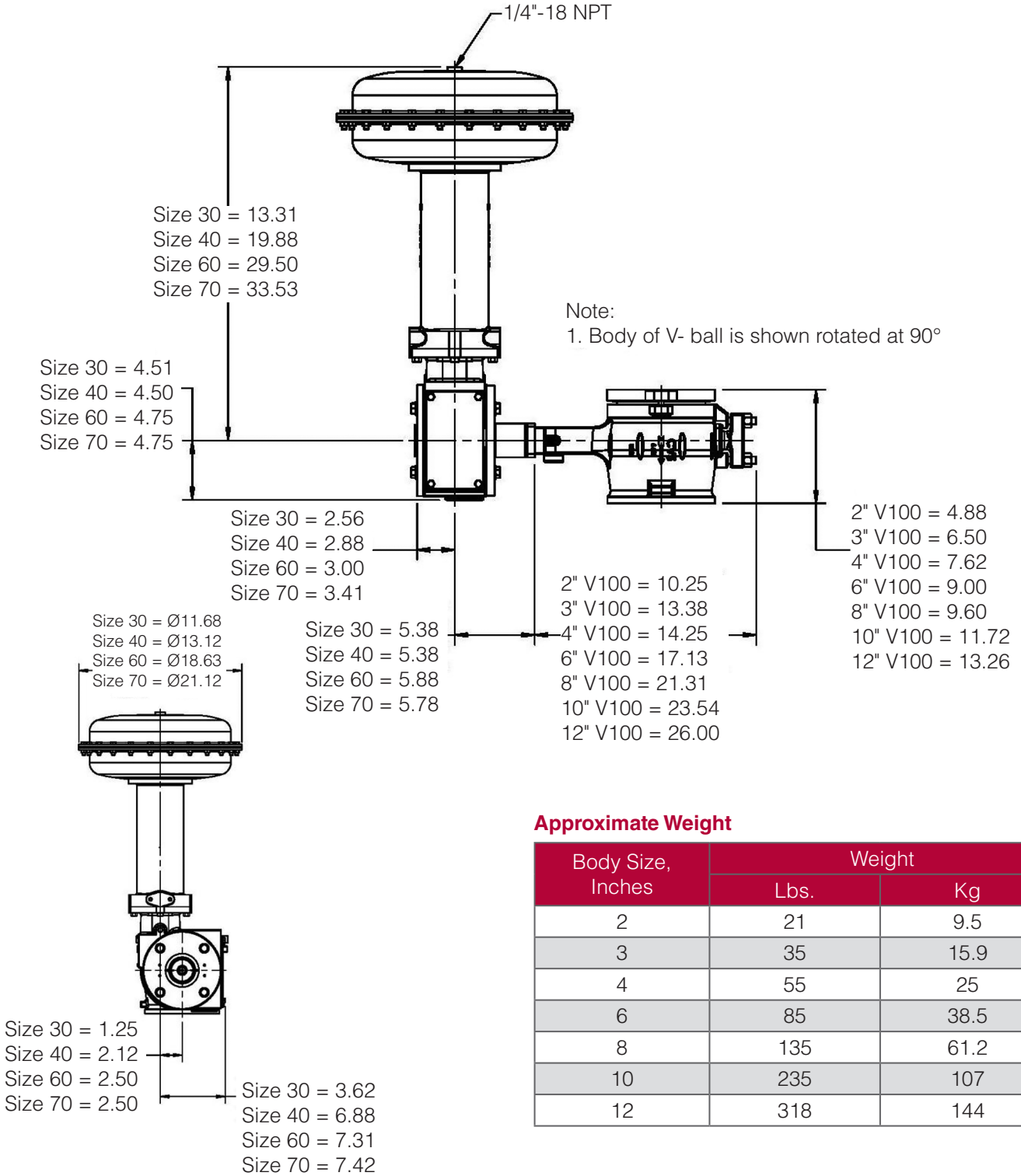

MARK V-100 SERIES CONTROL VALVE

FLOW COEFFICIENTS

Flow Coefficients:

Mark V-100

Line size: valve size=1:1

Valve Size Bore	Flow Coefficient - Cv Pressure Recovery - Km	Valve Rotation- 10° through 90°								
		10	20	30	40	50	60	70	80	90
2" Full	Cv	0.326	4.73	12.7	23.3	39.0	58.2	81.5	112	163
	Km	---	0,865	0,846	0,792	0,740	0,689	0,624	0,548	0,462
3" Full	Cv	1.49	7.44	22.3	44.6	73.7	114	164	242	372
	Km	---	0,792	0,774	0,757	0,723	0,672	0,593	0,533	0,462
4" Full	Cv	2.30	17.3	40.3	74.2	121	178	247	371	575
	Km	---	0,865	0,846	0,792	0,740	0,672	0,593	0,504	0,372
6" Full	Cv	4.64	30.2	78.9	148	231	331	463	664	1160
	Km	---	0,757	0,757	0,740	0,706	0,624	0,518	0,410	0,314
8" Full	Cv	5.66	47.8	120	225	354	512	749	1180	1770
	Km	---	0,828	0,810	0,774	0,706	0,608	0,462	0,360	0,281
10" Full	Cv	18.6	93.0	245	431	660	967	1350	1860	3100
	Km	---	0,810	0,810	0,774	0,723	0,656	0,578	0,476	0,325
12" Full	Cv	39.3	196	442	776	1210	1640	2370	4120	4910
	Km	---	0,828	0,828	0,723	0,672	0,593	0,518	0,436	0,325

Mark V-100

Line size: valve size=1.5:1

Valve Size Bore	Flow Coefficient - Cv Pressure Recovery - Km	Valve Rotation- 10° through 90°								
		10	20	30	40	50	60	70	80	90
2" Full	Cv	0.326	4.73	12.7	23.2	38.4	56.3	76.4	99.8	131
	Km	---	0,865	0,846	0,792	0,740	0,689	0,624	0,548	0,462
3" Full	Cv	1.49	7.44	22.3	44.5	73.1	112	157	222	311
	Km	---	0,792	0,774	0,757	0,723	0,672	0,593	0,533	0,462
4" Full	Cv	2.30	17.3	40.2	73.8	119	173	235	333	457
	Km	---	0,865	0,846	0,792	0,740	0,672	0,593	0,504	0,372
6" Full	Cv	4.64	30.2	78.9	148	230	326	450	625	1040
	Km	---	0,757	0,757	0,740	0,706	0,624	0,518	0,410	0,314
8" Full	Cv	5.66	47.8	120	224	351	503	723	1080	1490
	Km	---	0,828	0,810	0,774	0,706	0,608	0,462	0,360	0,281
10" Full	Cv	18.6	93.0	245	429	653	944	1290	1710	2520
	Km	---	0,810	0,810	0,774	0,723	0,656	0,578	0,476	0,325
12" Full	Cv	39.3	196	441	771	1190	1590	2230	3390	3940
	Km	---	0,828	0,828	0,723	0,672	0,593	0,518	0,436	0,325



Jordan Valve, a division of Richards Industries

3170 Wasson Road • Cincinnati, OH 45209

513.533.5600 • 800.543.7311 • 513.871.0105 (f)

info@richardsind.com • www.jordanvalve.com