

MODEL 8310HP-1+6 and MODEL 8310HP-1+8 DIFFERENTIAL PRESSURE REDUCING REGULATORS

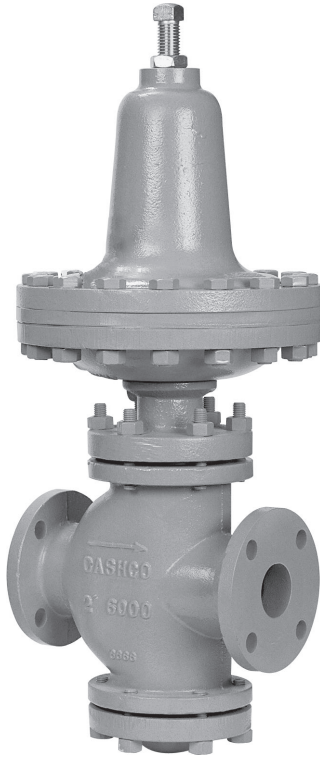

Model 8310HP 1+8

Models 8310HP-1+6 and 8310HP-1+8 are differential reducing regulators used to maintain a relatively constant pressure differential between the fluid loading pressure – P_{Load} , and the valve's outlet pressure – P_2 , with P_2 pressure higher than P_{Load} pressure.

Model 8310HP-1+6 is a single-diaphragm differential construction. Model 8310HP-1+8 is a double-diaphragm differential construction. A double-diaphragm design prevents the fluid passing through the body from mixing into the loading fluid pressurizing the spring chamber in the event of a diaphragm failure. (See Figures 1 and 2).

The design takes advantage of all the features of the basic 8310HP double seated reducing regulator; see Technical Bulletin 8310-BASIC-TB. The availability of optional construction is limited to those indicated in this Technical Bulletin.

APPLICATIONS

Widely applied in steam atomization systems using heavy oil (Nos. 3-6, Bunker C) to fuel burners.

A differential reducing regulator may also be applied for pressure loading service, allowing remote setpoint variation or sequential pressure control for batching operations. A “special case” of pressure loading is when a differential reducing regulator is applied together with a Model 764P pressure controller to provide very accurate pressure control; identified by Cashco as a Model 8310HP-1+6 “Accelerator”. Utilized on applications where near instantaneous reactions to flow or pressure variations are desired. Another “special” application is a “Smart Regulator”, which combines use of an I/P transducer and a differential reducing regulator.

Reference Technical Bulletin 8310HP/LP-BASIC-TB for pressure loading – Opt-20 – with no range spring utilized. Reference Technical Bulletin 1000HP-DIFF-TB for smaller differential valve flow capacities.



CAUTION

Option-1+6 contains a single diaphragm construction. In the event of diaphragm failure, the process fluid will mix with the loading fluid. If this is unacceptable, the Option-1+8 should be selected.

Option-1+8 contains a double diaphragm construction. In the event of diaphragm failure, leakage will be seen at the leakoff port between diaphragms. This will allow the user to repair the regulator before the second diaphragm fails.

STANDARD/GENERAL SPECIFICATIONS

Variations:	<p><u>8310HP-1+6</u>: “High Differential Pressure”, single diaphragm. <u>8310HP-1+8</u>: “High Differential Pressure”, double diaphragm.</p>	NOTES: 1. Maximum safety relief device setpoint is not to exceed – 8310HP-1+6: 1.10 x 8310HP-1+8: 1.10 x – the maximum Normal Outlet Pressure. 2. See Table 3 for maximum allowable pressure levels.
Body Sizes:	<p>1-1/2", 2", 2-1/2", 3", 4" (DN 40, 50, 65, 80, 100). (Complies with ASME B16.4 and B16.34)</p>	Temperature Range: Inlet and Outlet, all materials – <u>Liquid or Gas</u> -20 to +400°F (-29 to +205°C) <u>Steam</u> 406°F – SAT @ 250 psig (208°C – SAT @ 17.2 Barg).
Body/Spring Chamber Materials:	<p>CI/DI, CS/CS. CI = Cast iron. DI = Ductile iron. CS = Cast carbon steel.</p>	
End Connections:	<p><u>NPT</u>: 1-1/2" & 2" (DN 40 & 50) only. <u>Opt-30</u>: Integral Flanged: <u>125# Flgd</u>: All body sizes, CI body, flat faced (FF). <u>250# Flgd</u>: All body sizes, CI body, raised faced (RF). <u>150# Flgd</u>: All body sizes, CS body, raised faced (RF). <u>300# Flgd</u>: All body sizes, CS body, raised faced (RF). <u>Opt-34</u>: 14" Face to Face Flange Dim. (CS - Sizes 1-1/2" & 2" only)</p> <p>(Complies with ASME B16.4 and B16.34)</p>	Minimum Pressure Drop: <u>8310HP-1+6</u> : 3 psid (0.2 Bard). <u>8310HP-1+8</u> : 5 psid (0.3 Bard).
Trim Design:	<p>316 SST, double ported, metal or composition seated, inherently balanced. Metal or composition diaphragms. See Table 6 for trim materials.</p>	Seat Leakage: ANSI/FCI 70-2 (Rev. 1991), Class II.
Maximum Inlet Pressure:	<p><u>8310HP-1+6</u>: 400 psig (27.6 Barg). <u>8310HP-1+8</u>: 400 psig (27.6 Barg). (Consult factory for higher pressures.)</p>	Cv Capacity: See Tables 7 and 8 for flow capacity in Cv's. See Table 2 for “Wide Open Cv”; use for sizing safety relief device.
Differential Pressure Range:	<p><u>8310HP-1+6</u>: 10–100 psid (0.7–6.9 Bard). <u>8310HP-1+8</u>: 10–100 psid (0.7–6.9 Bard). (Consult factory for higher differential pressures.)</p>	Range Springs: Epoxy coated steel.
Maximum Loading Pressure:	<p>$P_2 = P_{Load} + \Delta P_{Diff}$ $Max P_{Load} = Max P_2 - Max \Delta P_{Diff}$</p>	External Bolting: Diaphragm flange, bonnet, bottom flange – high strength, zinc plated, heat treated steel.
Maximum Outlet Pressure:	<p><u>NORMAL OPERATION</u> – <u>8310HP-1+6</u>: 175 psig (12.1 Barg). <u>8310HP-1+8</u>: 175 psig (12.1 Barg).</p> <p><u>EMERGENCY OPERATION</u> – <u>8310HP-1+6</u>: 200 psig (13.8 Barg). <u>8310HP-1+8</u>: 200 psig (13.8 Barg).</p>	Gaskets: <u>Standard</u> : Graphite NBR. Not suitable for oxygen service.
		Outlet Pressure Balancing Valve: 1/2" – plated CS barstock; needle-type.
		Spring Chamber Vent Valve: Plated barstock CS, 1/8" M-NPT.
		Painting: <u>Standard</u> : All non-corrosion resistant portions to be painted with corrosion resistant epoxy paint per Cashco Spec #S-1606

OPTION SPECIFICATIONS

Option-1 (Std): CLOSING CAP. Use to prevent tampering with the set point pressure. Available on all spring chamber materials. Consists of a ductile iron closing cap, a sealing gasket, a sealing lock nut on the adjusting screw, and a 1/4" NPT female tapped spring chamber vent hole.

Option-15: STELLITED SEATS. Stellite seating surfaces on metal seating portions of plug and on both seat rings. See Table 3 for maximum allowable pressure drops.

Option- 30: INTEGRAL FLANGED END CONNECTIONS. Available with 125# FF and 250# RF flanges for cast iron body material or with 150# RF or 300# RF flanges for cast steel body material.

Option- 34: SPECIAL 14" FACE TO FACE DIMENSION FOR FLANGED END CONNECTIONS. CS body material, sizes 1-1/2" & 2" with 150# or 300# RF flanges only. See Opt.-30 for standard face to face dimension.

Option-56: SPECIAL CLEANING. Cleaning per Cashco Spec. #S-1542.

Option-65: FLOW-THRU SPRING CHAMBER. CS/CS body/spring chamber material ONLY. Spring chamber provided with two 1-1/4" (DN32) female NPT connections, allowing loading pressurizing fluid to be recirculated (see Figure 5). Recommended for heavy oils with high paraffin content.

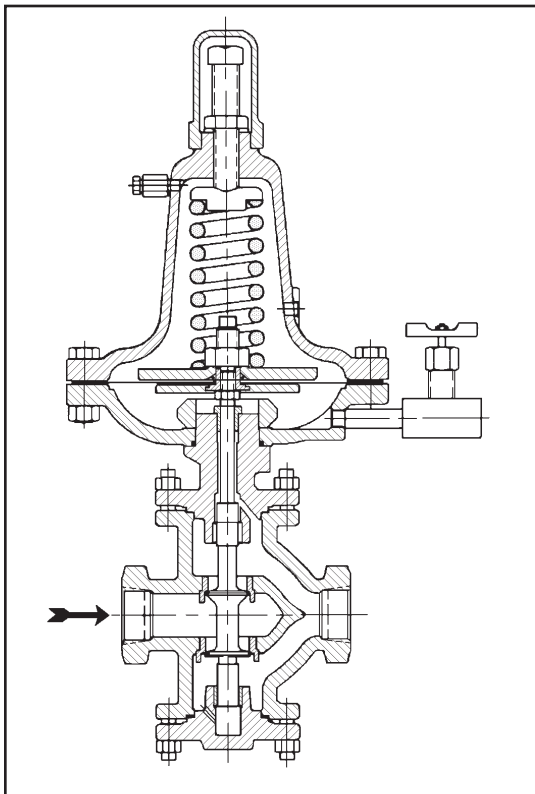

Figure 1: 8310HP-1+6, Single Diaphragm Const.

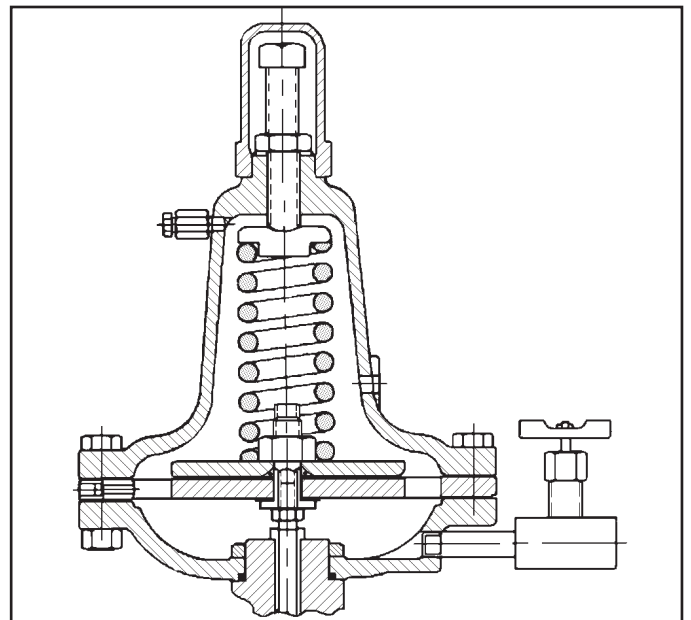

Figure 2: 8310HP-1+8, Double Diaphragm Const.

TECHNICAL SPECIFICATIONS

**TABLE 1
RANGE SPRINGS**

Model	Spring Range	
	psid	(Bard)
8310HP-1+6 or 8310HP-1+8	10-40	(0.7-2.7)
	30-100	(2.1-6.9)

**TABLE 2
MAXIMUM CAPACITY - Cv FOR SIZING SAFETY
RELIEF DEVICE (WITH PLUG WIDE OPEN)**

Maximum Cv per Size				
1-1/2"	2"	2-1/2"	3"	4"
(DN40)	(DN50)	(DN65)	(DN80)	(DN100)
27	40	55	78	100

- NOTES:** 1. Significant overpressure will do permanent damage to metal diaphragms and other internal parts.
 2. If overpressure is due to a high pressure condition from the P_L loading pressure, this pressure must be relieved prior to a safety device relieving at the differential valve's outlet.
 3. Do not exceed the P & T limits of Table 3.

**TABLE 3
MAXIMUM ALLOWABLE PRESSURE vs. TEMPERATURE;
FOR PRESSURE CONTAINMENT OF
BODY, FLANGES, BONNET & CASING**

--- 8310HP-1+6 or 8310HP-1+8 ---									
Materials of Construction Description - Abbreviation Body, Bottom Fig, Bonnet Diaph. Case/Spring Chamber	End Conn.	Inlet – Body				Outlet – Body & Spring Chamber			
		Pressure		Temperature		Pressure		Temperature	
		psig	(Barg)	°F	(°C)	psig	(Barg)	°F	(°C)
Cast Iron/ Ductile Iron (CI/DI) ASTM A126, Class B/ A395,GR. 60-40-18	125# Flgd.	200	(13.8)	-20 to +150	(-29 to +66)	200	(13.8)	-20 to +150	(-29 to +66)
		190	(13.1)	200	(94)	190	(13.1)	200	(94)
		175	(12.1)	250	(121)	175	(12.1)	250	(121)
		165	(11.4)	300	(149)	165	(11.4)	300	(149)
		150	(10.3)	353	(179)	150	(10.3)	353	(179)
	250# Flgd.	140	(9.7)	400	(205)	140	(9.7)	400	(205)
		375	(25.9)	300	(149)	200	(13.8)	-20 to +400	(-29 to +205)
		335	(23.1)	350	(177)				
	290	(20.0)	400	(205)					
	NPT	400	(27.6)	-20 to +150	(-29 to +66)	200	(13.8)	-20 to +400	(-29 to +205)
		400	(27.6)	200	(94)				
		400	(27.6)	250	(121)				
		375	(25.9)	300	(149)				
		335	(23.1)	350	(177)				
	Carbon Steel (CS/CS) ASTM A216, Gr. WCB per ANSI B16.5	150# Flgd.	290	(20.0)	400	(205)	200	(13.8)	-20 to +400
285			(19.7)	-20 to +100	(-29 to +38)				
260			(17.9)	200	(94)				
230			(15.9)	300	(149)				
300# Flgd. or NPT		200	(13.8)	400	(205)	200	(13.8)	-20 to +400	(-29 to +205)
		650	(44.8)	-20 to +300	(-29 to +149)				
		635	(43.8)	400	(205)				

TABLE 4 – MAXIMUM ALLOWABLE PRESSURE DROPS

Fluid	Max. Recommended Operating Pressure Drop				Option Number	Trim Designation Number
	Models 8310HP-1+6 & -1+8					
	Clean Fluid Industrial Quality		Unclean Fluid Pipeline Quality			
	psid	(Bard)	psid	(Bard)		
Non-Cavitating Liquid	200	(13.8)	100	(6.9)	None	All
	300	(20.7)	150	(10.3)	Stellited Opt-15	
Cavitating Liquids	Consult Factory		N/R		Stellited Opt-15	S1 Only
Gas	450	(31.0)	150	(10.3)	None	All
	450	(31.0)	300	(20.7)	Stellited Opt-15	
Steam	150	(10.3)	NR		None	S1, S36R
	300	(20.7)	150	(10.3)	Stellited Opt-15	

N/R: Not Recommended.

TABLE 5 – APPLICATIONS

Fluid	Recommended Construction	Trim Designation No.
Air or Industrial Gases	Composition Seat & Diaphragm	S3, S7
Chemicals	Metal Seat & Composition Diaphragm	S5, S40
	Metal Seat & Diaphragm	S1
	Composition Seat & Diaphragm	S3
	Composition Seat & Metal Diaphragm	S36, S36R
	Metal Seat & Composition Diaphragm	S5, S40
Hydrocarbon Gas or Liquids ‡	Metal Seat & Diaphragm	S1
	Composition Seat & Diaphragm	S3, S7, SR
	Metal Seat & Composition Diaphragm	S40
Water and Condensate	Metal Seat & Diaphragm	S1
	Composition Seat & Diaphragm	S3
	Metal Seat & Diaphragm	S1
Steam - Saturated or Superheated	Metal Seat & Diaphragm	S1

‡ In accordance with ASME B31.3 “process piping”, do not use Cast Iron Body for hydrocarbon or flammable fluid service with inlet pressures greater than 150 Psig (10.3 Barg) or temperatures greater than 300° F (149° C).

TABLE 6a – STAINLESS STEEL TRIM MATERIAL COMBINATIONS

Part	SST Trim Designation Number		
	Metal Diaphragm		
	S1	36	3R
Diaphragm	302 SST	302 SST	302 SST
Plug	316 SST	316 SST	316 SST
Seat Ring	316 SST	316 SST	316 SST
Seat	316 SST	TFE	Rulon LR
Stem	316 SST	316 SST	316 SST
Belleville Washer	300 Series SST	300 Series SST	300 Series SST
Stem Guides	Hardened 440C SST	Hardened 440C SST	Hardened 440C SST
Bonnet Plug	**	**	**
Pusher Plate	416 SST	416 SST	416 SST
Pressure Plate Nut	Steel	Steel	Steel
Pressure Plate O-ring	Fluorocarbon Elastomer	Fluorocarbon Elastomer	Fluorocarbon Elastomer
Diaphragm Casing O-Ring	TFE	TFE	TFE
Stem Bushing	303 SST	303 SST	303 SST
Bonnet Nut	Steel	Steel	Steel
Needle & Bleeder Valves	Steel	Steel	Steel
Temperature Range	-20 to +400°F (-29 to +205°C)	-20 to +400°F (-29 to +205°C)	-20 to +400°F (-29 to +205°C)
Available Variation Construction	All	All	All

** Same as body material.

NOTE: Cashco, Inc. does not recommend metal seated trim on any service flow that will dead end down stream of the pressure reducing regulator. Use composition seat for dead end service.

TABLE 6b – STAINLESS STEEL TRIM MATERIAL COMBINATIONS

Part	SST Trim Designation Number				
	Composition Diaphragm				
	S3	S40	S5	S7	S7R
Diaphragm	Neoprene	Neoprene	Fluorocarbon Elastomer	Fluorocarbon Elastomer	Fluorocarbon Elastomer
Plug	316 SST	316 SST	316 SST	316 SST	316 SST
Seat Ring	316 SST	316 SST	316 SST	316 SST	316 SST
Seat	TFE	316 SST	316 SST	TFE	Rulon LR
Stem	316 SST	316 SST	316 SST	316 SST	316 SST
Belleville Washer	300 Series SST	300 Series SST	300 Series SST	300 Series SST	300 Series SST
Stem Guides	Hardened 440C SST	Hardened 440C SST	Hardened 440C SST	Hardened 440C SST	Hardened 440C SST
Bonnet Plug	**	**	**	**	**
Pusher Plate	303 SST	303 SST	303 SST	303 SST	303 SST
Pressure Plate Nut	Steel	Steel	Steel	Steel	Steel
Pressure Plate O-ring	Fluorocarbon Elastomer	Fluorocarbon Elastomer	Fluorocarbon Elastomer	Fluorocarbon Elastomer	Fluorocarbon Elastomer
Diaphragm Casing O-Ring	TFE	TFE	TFE	TFE	TFE
Stem Bushing	303 SST	303 SST	303 SST	303 SST	303 SST
Bonnet Nut	Steel	Steel	Steel	Steel	Steel
Needle & Bleeder Valves	Steel	Steel	Steel	Steel	Steel
Temperature Range	-20 to +180°F (-29 to +83°C)	-20 to +180°F (-29 to +83°C)	-20 to +300°F (-29 to +149°C)	-20 to +300°F (-29 to +149°C)	-20 to +300°F (-29 to +149°C)
Available Variation Construction	8310HP-1+6	8310HP-1+6	8310HP-1+6	8310HP-1+6	8310HP-1+6

TABLE 7a
8310HP-1+6
CAPACITY TABLES – Cv - METAL DIAPHRAGM

Spring Range		Setpoint - Differential Pressure		1-1/2" Body			2" Body			2-1/2" Body			3" Body			4" Body		
				Droop			Droop			Droop			Droop			Droop		
psid	(Bard)	psid	(Bard)	10%	20%	30%	10%	20%	30%	10%	20%	30%	10%	20%	30%	10%	20%	30%
10-40	(0.7-2.7)	10	(0.7)	2.0	4.2	7.5	2.6	6.3	9.0	3.0	6.8	10.5	4.0	7.5	12.0	5.0	11.0	16.7
		15	(1.0)	3.0	8.0	12.0	4.0	9.2	14.5	5.0	11.2	16.5	6.0	12.5	19.0	8.5	17.5	23.5
		25	(1.7)	7.5	14.0	19.0	8.7	18.0	26.5	10.0	21.0	31.3	11.7	23.7	36.5	18.5	32.5	48.0
		35	(2.4)	11.5	19.7	25.2	14.0	27.5	35.7	16.5	32.3	45.7	18.7	37.2	55.7	26.5	51.5	78.7
30-100	(2.1-6.9)	50	(3.4)	6.2	11.7	16.7	7.3	14.8	22.0	8.0	16.8	25.2	9.5	19.0	28.7	13.0	26.8	39.5
		75	(5.2)	8.5	15.5	21.0	10.0	20.3	29.0	11.2	23.5	35.0	13.0	27.0	40.5	18.0	36.5	55.7
		100	(6.9)	8.7	18.0	21.2	10.5	21.0	29.5	12.0	23.8	36.0	13.7	27.2	41.3	18.7	37.5	56.5

TABLE 7b
8310HP-1+8
CAPACITY TABLES – Cv - METAL DIAPHRAGM

Spring Range		Setpoint - Differential Pressure		1-1/2" Body			2" Body			2-1/2" Body			3" Body			4" Body		
				Droop			Droop			Droop			Droop			Droop		
psid	(Bard)	psid	(Bard)	10%	20%	30%	10%	20%	30%	10%	20%	30%	10%	20%	30%	10%	20%	30%
10-40	(0.7-2.7)	10	(0.7)	1.6	3.36	6.0	2.1	5.0	7.2	2.4	5.4	8.4	3.2	6.0	9.6	4.0	8.8	13.4
		15	(1.0)	2.4	6.4	9.6	3.2	7.4	11.6	4.0	9.0	13.2	4.8	10.0	15.2	6.8	14.0	18.8
		25	(1.7)	6.0	11.2	15.2	7.0	14.4	21.2	8.0	16.8	25.0	9.3	18.9	29.2	14.8	26.0	38.4
		35	(2.4)	9.2	15.8	20.1	11.2	22.0	28.5	13.2	25.8	36.6	15.0	29.7	44.6	21.2	41.2	63.0
30-100	(2.1-6.9)	50	(3.4)	4.9	9.4	13.4	5.8	11.8	17.6	6.4	13.4	20.2	7.6	15.2	23.0	10.4	21.4	31.6
		75	(5.2)	6.8	12.4	16.8	8.0	16.2	23.2	8.9	18.8	28.0	10.4	21.6	32.4	14.4	29.2	44.6
		100	(6.9)	7.0	14.4	17.0	8.4	16.8	23.6	9.6	19.0	28.8	11.0	21.8	33.0	14.7	30.0	45.2

TABLE 8
8310HP-1+6
CAPACITY TABLES – Cv - COMPOSITION DIAPHRAGM

Spring Range		Setpoint - Differential Pressure		1-1/2" Body			2" Body			2-1/2" Body			3" Body			4" Body		
				Droop			Droop			Droop			Droop			Droop		
psid	(Bard)	psid	(Bard)	10%	20%	30%	10%	20%	30%	10%	20%	30%	10%	20%	30%	10%	20%	30%
10-40	(0.7-2.7)	10	(0.7)	6.0	11.2	16.2	7.0	14.0	21.5	8.0	16.2	24.8	9.2	18.7	28.7	13.0	26.2	39.1
		15	(1.0)	7.5	13.8	19.5	9.1	18.7	27.2	11.2	21.2	32.1	12.5	24.1	36.5	17.0	33.5	50.8
		25	(1.7)	10.5	19.0	25.0	13.0	26.3	34.8	15.0	31.0	44.3	17.6	35.5	53.5	24.0	48.8	73.7
		35	(2.4)	16.0	25.4	26.2	21.4	35.7	39.0	24.5	45.7	52.4	28.1	56.5	72.2	38.8	78.7	98.2
30-100	(2.1-6.9)	50	(3.4)	10.5	18.7	24.5	13.0	26.1	34.2	15.0	30.0	43.7	17.4	34.8	52.1	24.0	47.5	72.2
		75	(5.2)	15.2	24.7	26.2	20.2	34.7	38.7	22.9	43.7	51.2	26.5	52.8	70.0	36.7	72.8	97.5
		100	(6.9)	12.1	21.3	26.0	15.7	29.4	36.9	17.7	36.0	47.5	20.4	41.2	61.3	28.0	57.0	86.0

The contents of this publication are presented for informational purposes only, and while every effort has been made to ensure their accuracy, they are not to be construed as warranties or guarantees, express or implied, regarding the products or services described herein or their use or applicability. We reserve the right to modify or improve the designs or specifications of such product at any time without notice. Cashco, Inc. does not assume responsibility for the selection, use or maintenance of any product. Responsibility for proper selection, use and maintenance of any Cashco, Inc. product remains solely with the purchaser.

MODEL 8310HP-1+6 *
DIMENSIONS AND WEIGHTS - ENGLISH UNITS

Size Inches	End Connection	Dimensions - Inches								Approximate Ship Weight lbs.		
		A	B	C	D	E	F*	G*	H*	HP-1+6	HP-1+8	
		1-1/2" **	NPT	3.69	8.00	11.25	4.75	6.89	11.12	20.25	20.50	100
	125/150# Flgd.	4.06	8.75	106	116							
	250/300# Flgd.	4.31	9.25	114	124							
2" ***	NPT	4.25	9.26	11.25	6.38	8.44	12.69	21.50	22.00	140	150	
		125/150# Flgd.	4.62							10.00	152	162
		250/300# Flgd.	4.88							10.50	156	166
2-1/2"	125/150# Flgd.	5.06	10.88	11.25	6.38	8.44	12.69	21.50	22.00	180	190	
	250/300# Flgd.	5.38	11.50							185	195	
3"	125/150# Flgd.	5.50	11.75	11.25	7.69	9.74	14.00	22.75	23.50	205	215	
	250/300# Flgd.	5.88	12.50							213	223	
4"	125/150# Flgd.	6.56	13.88	11.25	7.69	9.74	14.00	22.75	23.50	230	240	
	250/300# Flgd.	6.88	14.50							248	258	

* Add 0.50 inch for Model 8310HP-1+8 variation.
 ** 1-1/2" Size CS body material with Opt-34: "A" dim. = 7.31" & "B" dim = 14.00"
 *** 2" Size CS body material with Opt-34: "A" dim. = 7.38" & "B" dim = 14.00"

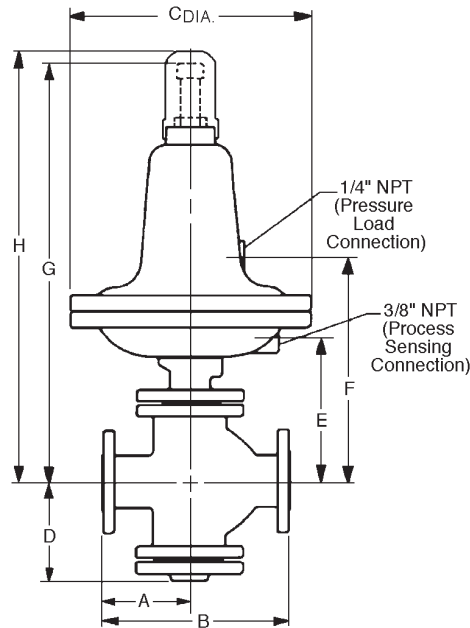

MODEL 8310HP-1+6 *
DIMENSIONS AND WEIGHTS - METRIC UNITS

Size (DN)	End Connection	Dimensions (mm)								Approximate Ship Weight (Kg)		
		A	B	C	D	E	F*	G*	H*	HP-1+6	HP-1+8	
		(40) **	NPT	94	203	286	121	175	283	514	521	45
	125/150# Flgd.	103	222	48	53							
	250/300# Flgd.	110	235	52	56							
(50) ***	NPT	108	235	286	162	214	322	546	559	63	68	
		125/150# Flgd.	117							254	59	59
		250/300# Flgd.	124							267	71	75
(65)	125/150# Flgd.	129	276	286	162	214	322	546	559	82	86	
	250/300# Flgd.	137	292							84	88	
(80)	125/150# Flgd.	140	298	286	195	247	356	578	597	93	97	
	250/300# Flgd.	149	318							97	101	
(100)	125/150# Flgd.	167	352	286	195	247	356	578	597	104	109	
	250/300# Flgd.	175	368							112	117	

* Add 13mm for Model 8310HP-1+8 variation.
 ** DN40" Size CS body material with Opt-34: "A" dim. = 185mm & "B" dim = 356mm.
 *** DN50 Size CS body material with Opt-34: "A" dim. = 187mm & "B" dim = 356mm.

MODEL 8310 DIFF - PRODUCT CODER

03/24/20

An "X" in POS 12 followed by a 5-digit control number overrides remaining selections.

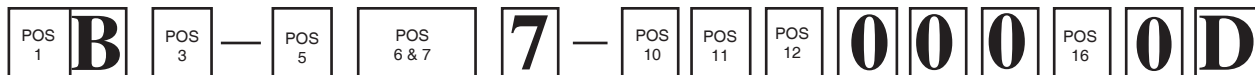

POSITION 1 - VALVE TYPE	
Description	CODE
Model 8310HP-1+6	N
Model 8310HP-1+8	P

POSITION 3 - SIZE		
Size		CODE
in	(DN)	
1-1/2"	(40)	8
2"	(50)	9
2-1/2" *	(65)	A
3" *	(80)	B
4" *	(100)	C

*Flanged only.

POSITION 5 - BODY & SPRING CHAMBER MATERIALS	
Body / Sp. Ch.	CODE
CI / DI	1
CS/CS	5

See TB Table 3 for material limitations for Design Pressure Ratings.

POSITION 6 & 7 - TRIM	
Body Material	
Desig.	CS or SST CODE
S1	S1
S5 *	S5
S40 *	40
S36	36
S36R	3R
S7*	S7
S7R*	SR
S3*	S3

* Available for -1+6 only.

POSITION 10 - END CONNECTIONS	
Description	CODE
NPT - Screwed	1
-30 Opt. Integral Flanged	
125 LB Flgs CI Only	3
150 LB Flgs CS Only	6
250 LB Flgs CI Only	5
300 LB Flgs CS Only	7
-34 Opt. - 150 LB RF Flgs. 14" F to F Dimension (Sizes 1-1/2" & 2" only) *	V
-34 Opt. - 300 LB RF Flgs. 14" F to F Dimension (Sizes 1-1/2" & 2" only) *	W

* CS body material only. Nipples & flanges of same material as body.

POSITION 11 - RANGE SPRINGS		
Steel Range Spring 8310HP 1+6 & 1 + 8		CODE
psid	(Bard)	
10 - 40	(.69-2.8)	1
30 - 100	(2.1-6.9)	2

POSITION 12 - TRIM VARIATIONS		
Description	Option	CODE
No Special Trim Variation	--	0
Stellited Seat Surface - S1 and S5 Trim Only.	-15	A
For Special Construction Contact Cashco for Special Product Code.	SPQ	X

POSITION 16 - CERTIFICATE OPTIONS		
Description	Option	CODE
No Option	-	0
Special Cleaning: Per Cashco Spec #S-1542.	-56	N

*** For information on ATEX see pages 10 & 11 on the IOM.**

Cashco, Inc.
P.O. Box 6
Ellsworth, KS 67439-0006
PH (785) 472-4461
Fax. # (785) 472-3539
www.cashco.com
email: sales@cashco.com
Printed in U.S.A. 8310HP-DIFF-TB

Cashco GmbH
Handwerkerstrasse 15
15366 Hoppegarten, Germany
PH +49 3342 30968 0
Fax. No. +49 3342 30968 29
www.cashco.com
email: germany@cashco.com

Cashco do Brasil, Ltda.
Al.Venus, 340
Indaiatuba - Sao Paulo, Brazil
PH +55 11 99677 7177
Fax. No.
www.cashco.com
email: brazil@cashco.com