

Type 8791 REV.2

Positioner SideCONTROL BASIC

Electro-pneumatic positioner

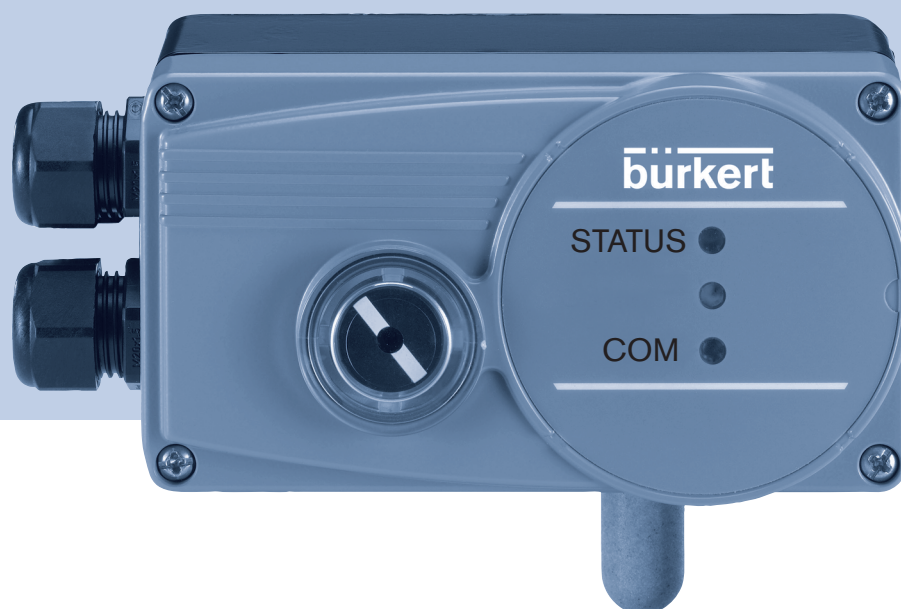

Operating instructions

We reserve the right to make technical changes without notice.
Technische Änderungen vorbehalten.
Sous réserve de modifications techniques.

© Bürkert Werke GmbH & Co. KG, 2009–2022

Operating Instructions 2211/04_ENen_00815310/Original DE

Electro-pneumatic positioner Type 8791 REV.2

CONTENT

1	ABOUT THESE INSTRUCTIONS	8
1.1	Symbols.....	8
1.2	Definition of terms.....	9
1.3	Firmware modifications	9
2	INTENDED USE	10
3	BASIC SAFETY INSTRUCTIONS	11
4	GENERAL NOTES.....	12
4.1	Contact address.....	12
4.2	Warranty	12
4.3	Information on the Internet.....	12
5	PRODUCT DESCRIPTION.....	13
5.1	General description.....	13
5.1.1	Characteristics.....	13
5.1.2	Combination with valve types and mounting variants.....	14
5.1.3	Optional external position feedback unit with inductive proximity switch.....	14
5.1.4	Overview of mounting options.....	15
6	STRUCTURE.....	16
6.1	Illustration.....	16
7	FUNCTION	17
7.1	Functional diagram	17
7.2	Position control function.....	18
7.2.1	Schematic presentation of the position control.....	19
7.2.2	Functions of the positioner software	20
7.3	Positioner interfaces	22
8	TECHNICAL DATA	23
8.1	Standards and directives.....	23
8.2	Operating conditions	23

8.3	Mechanical data.....	23
8.4	Type label	24
8.5	Electrical data	24
8.5.1	Electrical data, without fieldbus communication.....	24
8.5.2	Electrical data, IO-Link	25
8.5.3	Electrical data, bÜS.....	25
8.6	Pneumatic data	26
8.7	Safety end positions after failure of the electrical or pneumatic auxiliary power.....	27
8.8	Positioner factory settings.....	28
8.8.1	Functions that can be activated via DIP switch.....	28
8.8.2	Functions that can be activated via the communication software	28
9	OPERATION.....	29
9.1	Safety instructions	29
9.2	Operating state.....	29
9.3	Operating and display elements of the positioner	29
9.3.1	Assignment of the keys	30
9.3.2	DIP switch function.....	31
9.3.3	LED display.....	32
9.3.4	Status indicator.....	32
9.3.5	Status LED, green.....	34
9.4	Error notifications	35
9.4.1	Notifications on device status: Out of specification.....	35
9.4.2	Messages: Actuator is moving to safety position.....	35
10	FUNCTIONS.....	37
10.1	Basic functions.....	37
10.1.1	DIR.CMD - Inversion of direction of the positioner set-point value	38
10.1.2	CUTOFF - Sealing function for the positioner.....	39
10.1.3	CHARACT - Characteristic correction between the input signal (position set-point value) and stroke.....	40
10.1.4	INPUT - Input of standard signal (only variant without fieldbus communication)	42

10.1.5	RESET/FACTORY RESET - Reset device to factory settings	43
10.1.6	X.TUNE - Automatic calibration of the positioner to the respective operating conditions	43
10.2	Auxiliary functions	44
10.2.1	DIR.ACT - Actuator inversion of direction.....	45
10.2.2	SPLTRNG - Signal split range	46
10.2.3	X.LIMIT - Stroke limitation.....	47
10.2.4	X.TIME - Actuating time limit	48
10.2.5	X.CONTROL - control parameter of the positioner	49
10.2.6	SAFEPOS - Definition of safety position	49
10.2.7	SIG.ERROR - Configuring the cable break detection (only for variants without fieldbus communication).....	50
10.2.8	BINARY.IN - Configuring the digital input (only for variants without fieldbus communication).....	50
10.2.9	OUTPUT (variant) - Configuring the analogue output (only for variants without fieldbus communication).....	51
10.2.10	Setting LED operation mode, device status	51
11	MOUNTING AND INSTALLATION	52
11.1	Safety instructions	52
11.2	Mounting on a continuous valve with linear actuator according to NAMUR	53
11.2.1	Attachment kit (in accordance with IEC 534-6) on linear actuators (order number 787215)	53
11.2.2	Installation.....	54
11.2.3	Attaching the mounting bracket	56
11.2.4	Aligning the lever mechanism.....	57
11.3	Mounting on a continuous valve with rotary actuator.....	58
11.3.1	Attachment kit (in accordance with VDI/VDE 3845) on rotary actuator (Order number 787338).....	58
11.3.2	Installation.....	58
11.4	Remote operation with external position sensor.....	61
11.4.1	Attachment accessories	61

11.4.2	Connection and start-up of the remote sensor Type 8798.....	62
12	PNEUMATIC CONNECTION.....	63
12.1	Safety instructions.....	63
13	ELECTRICAL INSTALLATION WITHOUT FIELDBUS COMMUNICATION.....	65
13.1	Safety instructions.....	65
13.2	Electrical installation with circular plug-in connector.....	65
13.2.1	Designation of circular plug-in connector M12, 8-pin.....	65
13.2.2	Pin assignment for input signals from control centre (e.g. PLC).....	66
13.2.3	Pin assignment for the output signals to the control centre (PLC, for example), only for the analogue output variant.....	66
13.2.4	Pin assignment for operating voltage.....	67
13.3	Electrical installation with cable gland.....	67
13.3.1	Designation of screw-type terminals.....	67
13.3.2	Connection of terminals.....	67
13.3.3	Terminal assignment for input signals from control centre (e.g. PLC).....	68
13.3.4	Terminal assignment for the output signals to the control centre (PLC, for example), only for analogue output variant.....	68
13.3.5	Terminal layout for operating voltage.....	69
13.3.6	Terminal assignment for external position sensor (only for remote variant).....	69
14	ELECTRICAL INSTALLATION, IO-LINK.....	70
14.1	Connection assignment for external position sensor (only for remote variant).....	70
15	ELECTRICAL INSTALLATION, BÜS.....	72
15.1	Connection assignment for external position sensor (only for remote variant).....	72
16	START-UP.....	73
16.1	Safety instructions.....	73
16.2	Defining base settings.....	73
16.2.1	Execute the X.TUNE automatic adjustment.....	73

16.3	Set device with Bürkert Communicator	74
16.3.1	Connecting the IO-Link device to the Bürkert Communicator	74
16.3.2	Connecting the büS device to the Bürkert Communicator	75
17	IO-LINK	76
17.1	Information, IO-Link	76
17.2	Technical data, IO-Link	76
17.3	Configuring the fieldbus	76
18	BÜS	77
18.1	Information, büS	77
18.2	Configuring the fieldbus	77
19	MAINTENANCE	78
20	ACCESSORIES	78
20.1	Communication software	78
21	PACKAGING, TRANSPORT, DISPOSAL	79

1 ABOUT THESE INSTRUCTIONS

The operating instructions describe the entire life cycle of the device.

→ Keep these instructions ready to hand at the operating site.

Important safety information!

- ▶ Read these instructions carefully.
- ▶ Above all, observe the safety instructions, intended use and operating conditions.
- ▶ Persons who work on the device must read and understand these instructions.

1.1 Symbols



DANGER!

Warns of an immediate danger.

- ▶ Failure to observe these instructions will result in death or serious injuries.



WARNING!

Warns of a potentially hazardous situation.

- ▶ Failure to observe these instructions may result in serious injuries or death.



CAUTION!

Warns of a potential danger.

- ▶ Failure to observe these instructions may result in moderate or minor injuries.

WARNING!

Warns of damage.

- ▶ Failure to observe these instructions may result in damage to the device or the system.



Indicates important additional information, tips and recommendations.



Refers to information in these instructions or in other documentation.

- ▶ Designates instructions to avoid a danger.

→ Highlights a procedure which you must carry out.

- ✔ Designates a result.

Menu Marks a user interface text.

1.2 Definition of terms

In these instructions, the term “device” refers to the following types of devices:

Type 8791 positioner REV.2

The term “bÜS” (Bürkert system buS) used in this manual stands for the communication buS developed by Bürkert, based on the CANopen protocol.

The abbreviation “Ex” used in these instructions always stands for “potentially explosive atmosphere”.

1.3 Firmware modifications

From firmware version	Modifications
A.1.6	Information for “Valve position in between” changed from “LED off” to “LED lights white”

2 INTENDED USE

The Positioner type 8791 REV.2 has been designed for mounting on pneumatic actuators of process valves to control the flow of media. The permitted media are listed in the "Technical data".

- ▶ Use the device only as intended. Non-intended use of the device may be dangerous to people, nearby equipment and the environment.
- ▶ Prerequisites for safe and trouble-free operation are correct transportation, correct storage, installation, start-up, operation and maintenance.
- ▶ To use the device, observe the permitted data, operating conditions and application conditions. These specifications can be found in the contract documents, the operating instructions and on the Type label.
- ▶ Use the device only in conjunction with third-party devices and components recommended or approved by Bürkert.
- ▶ When used outdoors, protect the device against adverse weather conditions.
- ▶ In potentially explosive areas, only use devices that are approved for these areas. These devices are identified by a separate "Ex" type label. Before use, note the information on the separate Ex type label and the Ex additional instructions or the separate Ex operating Instructions.
- ▶ Do not use pulsating DC voltage (rectified AC voltage without smoothing) as the supply voltage.

3 BASIC SAFETY INSTRUCTIONS

These safety instructions do not take into account any unforeseen circumstances and events which occur during installation, operation and maintenance.

The operator is responsible for observing the location-specific safety regulations, also with reference to personnel.



DANGER!

Risk of injury due to high pressure and any escaping media.

- ▶ Switch off the pressure before working on the device or system. Vent or empty the lines.



DANGER!

Risk of injury from electric shock.

- ▶ Switch off the power supply before working on the device or system. Secure against reactivation.
- ▶ Observe the applicable accident prevention and safety regulations for electrical devices.



To prevent injuries, observe the following:

- ▶ Ensure that the device or system cannot be activated unintentionally.
- ▶ Only trained technicians may perform installation and maintenance work.
- ▶ Perform installation and maintenance work using suitable tools only.
- ▶ Do not make any changes to the device and do not subject it to mechanical stress.
- ▶ Use the device only when it is in perfect condition and in accordance with the operating instructions.
- ▶ Observe the general rules of technology.
- ▶ Install the device according to the regulations applicable in the respective country.
- ▶ Do not feed any aggressive or combustible media into the connections of the device.
- ▶ Do not feed any liquids into the device's connections.
- ▶ Only restart the process in a controlled manner following disruptions. Observe sequence:
 1. Apply supply voltage or pneumatic supply.
 2. Pressurise with medium.
- ▶ Observe the intended use.

WARNING!

Electrostatically sensitive components and assemblies.

The device contains electronic components that are susceptible to the effects of electrostatic discharging (ESD). Components that come into contact with electrostatically charged persons or objects are at risk. In the worst-case scenario, they will be destroyed immediately or will fail after start-up.

- ▶ Observe requirements of EN 61340-5-1 for minimising or avoiding the possibility of damage caused by sudden electrostatic discharge.
- ▶ Also ensure that you do not touch the electronic components when the voltage is applied.

4 GENERAL NOTES

4.1 Contact address

Germany

Bürkert Fluid Control System
Sales Centre
Christian-Bürkert-Str. 13-17
D-74653 Ingelfingen
Tel. + 49 (0) 7940 - 10 91 111
Fax + 49 (0) 7940 - 10 91 448
Email: info@burkert.com

International

The contact addresses can be found on the back pages of the printed operating instructions.

Also on the Internet at:

country.burkert.com

4.2 Warranty

A precondition for the warranty is that the Type 8791 positioner is used as intended and that the specified conditions of use are taken into account.

4.3 Information on the Internet

Operating instructions and data sheets for the Type 8791 can be found on the Internet at:

country.burkert.com

5 PRODUCT DESCRIPTION

5.1 General description

The Type 8791 positioner is a digital electro-pneumatic positioner for pneumatically actuated continuous valves. The device contains the main functional groups

- Position sensor
- Pilot valve system (electro-pneumatic actuating system)
- Microprocessor electronics

The position sensor measures the current positions of the continuous valve.

The microprocessor electronics continuously compare the current position (actual value) with a position set-point value prescribed by the standard signal input and supply the positioner with the result.

If there is a control difference, the pilot valve system corrects the actual position.

5.1.1 Characteristics

- **Variant**

The positioner is available with position control function.

The position of the actuator is controlled according to the position set-point value. The position set-point value is specified by an external standard signal (or via fieldbus).

- **Position sensor**

- Internal high-resolution conductive plastic potentiometer or
- External contactless wear-free position sensor (remote).

- **Microprocessor-controlled electronics assembly**

for signal processing, closed-loop control and valve control.

- **Control module**

The device is controlled with two keys and four DIP switches.

Two LEDs (one RGB-LED for the device status and one green LED for the status of the communication interface) enable different device statuses to be displayed.

- **Pilot valve system**

The actuating system consists of two solenoid valves and four diaphragm amplifiers. For single-acting actuators, working port 2 must be sealed with a threaded plug.

- **Position feedback**

The position of the valve can be transferred either via 2 proximity switches or via a 0/4...20 mA output (variant without fieldbus communication) or transferred digitally via a fieldbus communication (for example, büS, IO-Link) to the PLC. The proximity switches or basic positions can be changed by the user using control vanes.

- **Pneumatic interfaces**

Internal thread G1/4"

- **Electrical interfaces**

(circular plug-in connector or cable gland)

- **Communication interface**

To exchange process data and for configuration and parameterisation

- **Housing**

Plastic-coated aluminium housing with hinged cover and captive screws.

The housing of the positioner is protected against internal pressure that is too high, for example following leakages, by a pressure limiting valve.

- **Mounting**
On linear actuator in accordance with NAMUR recommendation (DIN IEC 534-6) or on rotary actuator in accordance with VDI/VDE 3845.
- **Optional**
Remote variant for standard rail assembly or for mounting brackets

5.1.2 Combination with valve types and mounting variants

The positioner Type 8791 can be attached to various continuous valves. For example, to valves with piston, diaphragm or rotary actuators. The actuators can be single- or double-acting.

- In single-acting actuators, only one chamber is aerated and vented. The pressure generated works against a spring. The piston moves until a force equilibrium is reached between the compressive force and spring force. For this, one of the two air connections is sealed with a threaded plug.
- For double-acting actuators, the chambers on both sides of the piston are pressurised. The aeration of one chamber aerates the other chamber and vice versa. No spring is installed in the actuator for this variant.

For the positioner Type 8791, two basic device variants are offered, which differ in terms of the attachment option and the position sensor.

NAMUR device variant:

An internal device position sensor is used which is designed as a rotary potentiometer. The positioner is mounted directly on the actuator.

Remote device variant:

An external position sensor (linear or rotative) is connected via a digital interface.

The positioner is either mounted with a standard rail or with a mounting bracket on a wall (remote variant) for this.

5.1.3 Optional external position feedback unit with inductive proximity switch

The positioner Type 8791 can be fitted with an external position feedback unit (see data sheet in the accessory).

The installation and settings are described in the assembly instructions enclosed with the external position feedback unit.

The assembly instructions can also be found on the Internet.

country.burkert.com → Type 8791

5.1.4 Overview of mounting options

<p>NAMUR mounting on rotary actuator</p>	
<p>NAMUR mounting with mounting bracket on a linear actuator</p>	
<p>Remote mounting with fastening bracket</p>	
<p>Remote mounting on standard rail</p>	

Table 1: Overview of mounting options

MAN 1000402005 EN Version: E Status: RL (released | freigegeben) printed: 19.02.2026

6 STRUCTURE

The positioner Type 8791 consists of the microprocessor-controlled electronic mechanism, the position sensor and the pilot valve system.

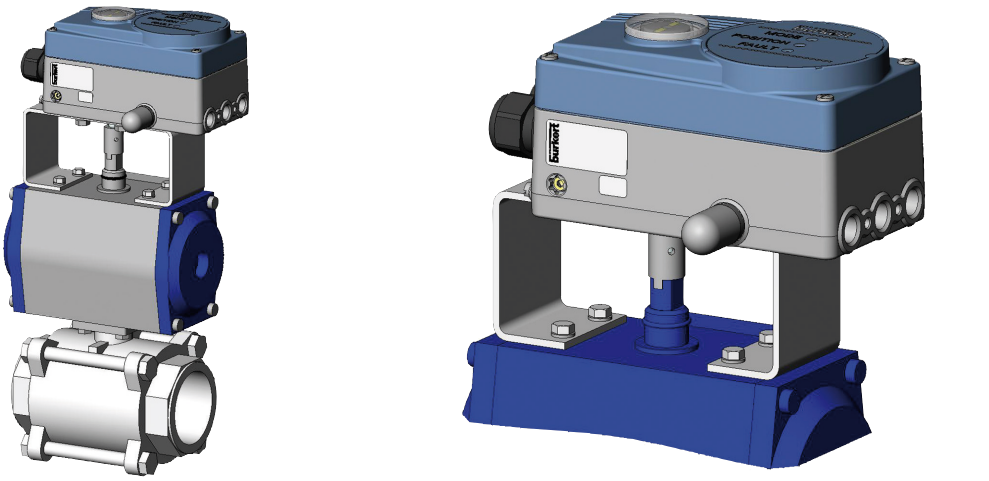
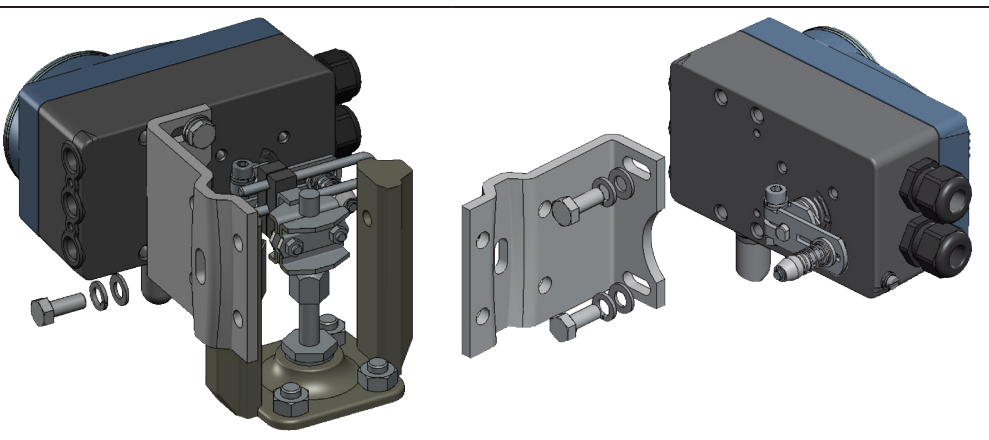
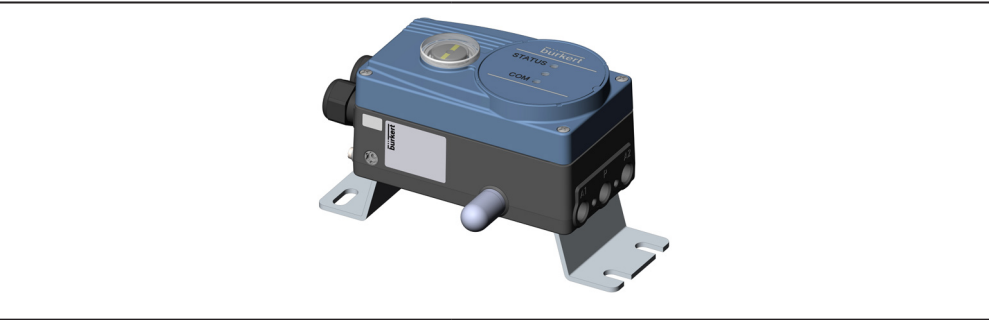
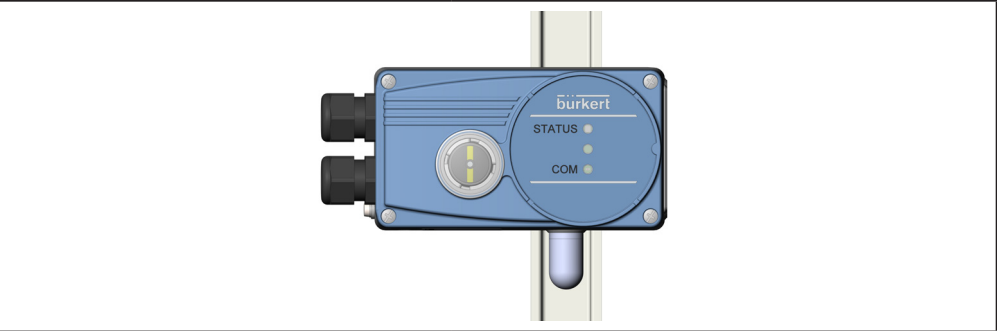
The device is controlled with two keys and four DIP switches. Two LEDs (one RGB-LED for the device status and one green LED for the status of the communication interface) enable different device statuses to be displayed.

The pilot valve system for single- and double-acting actuators consists of two solenoid valves.

6.1 Illustration

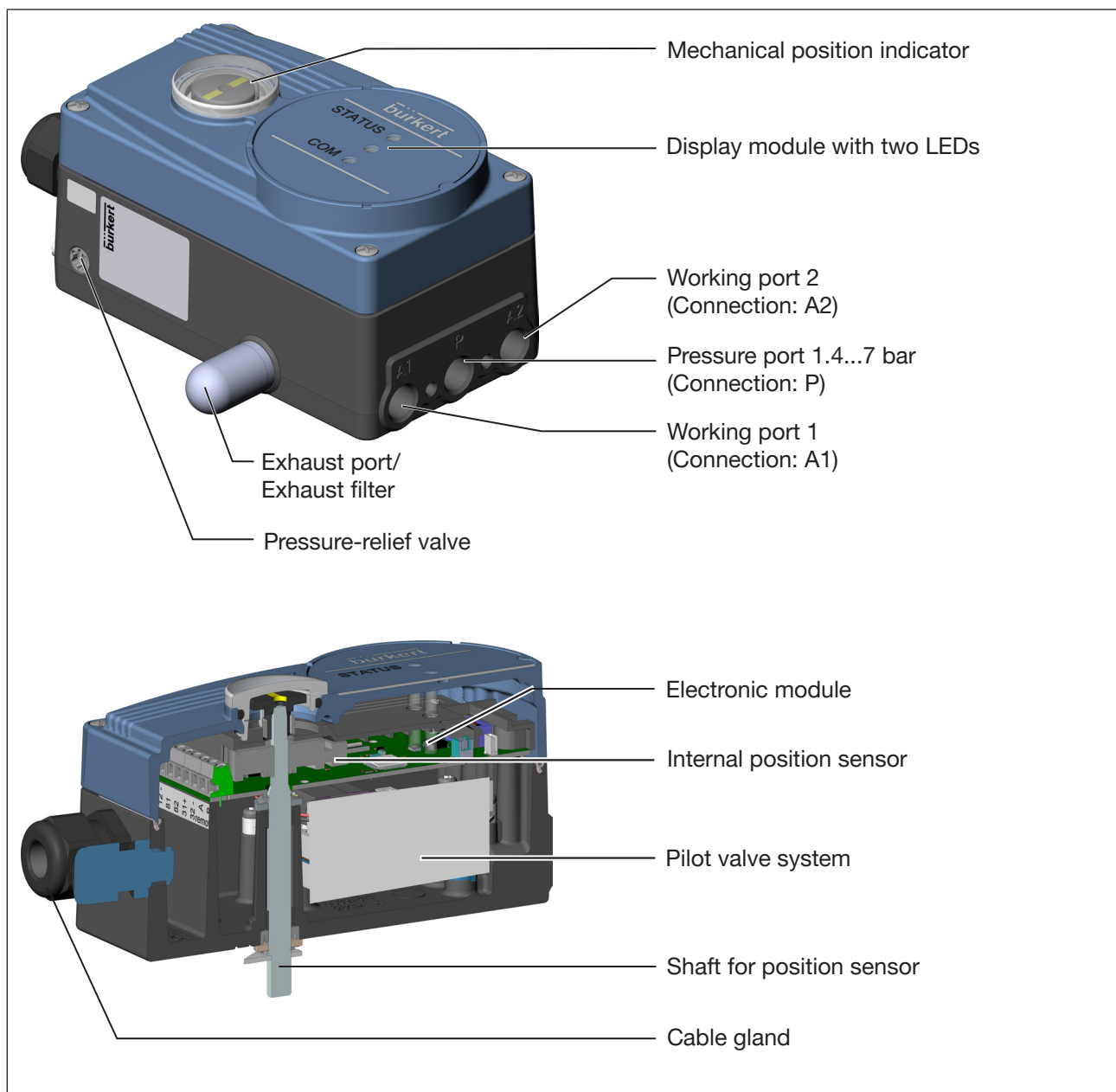

Fig. 1: Structure, positioner Type 8791

7 FUNCTION

7.1 Functional diagram

Exemplary presentation with single-acting actuator

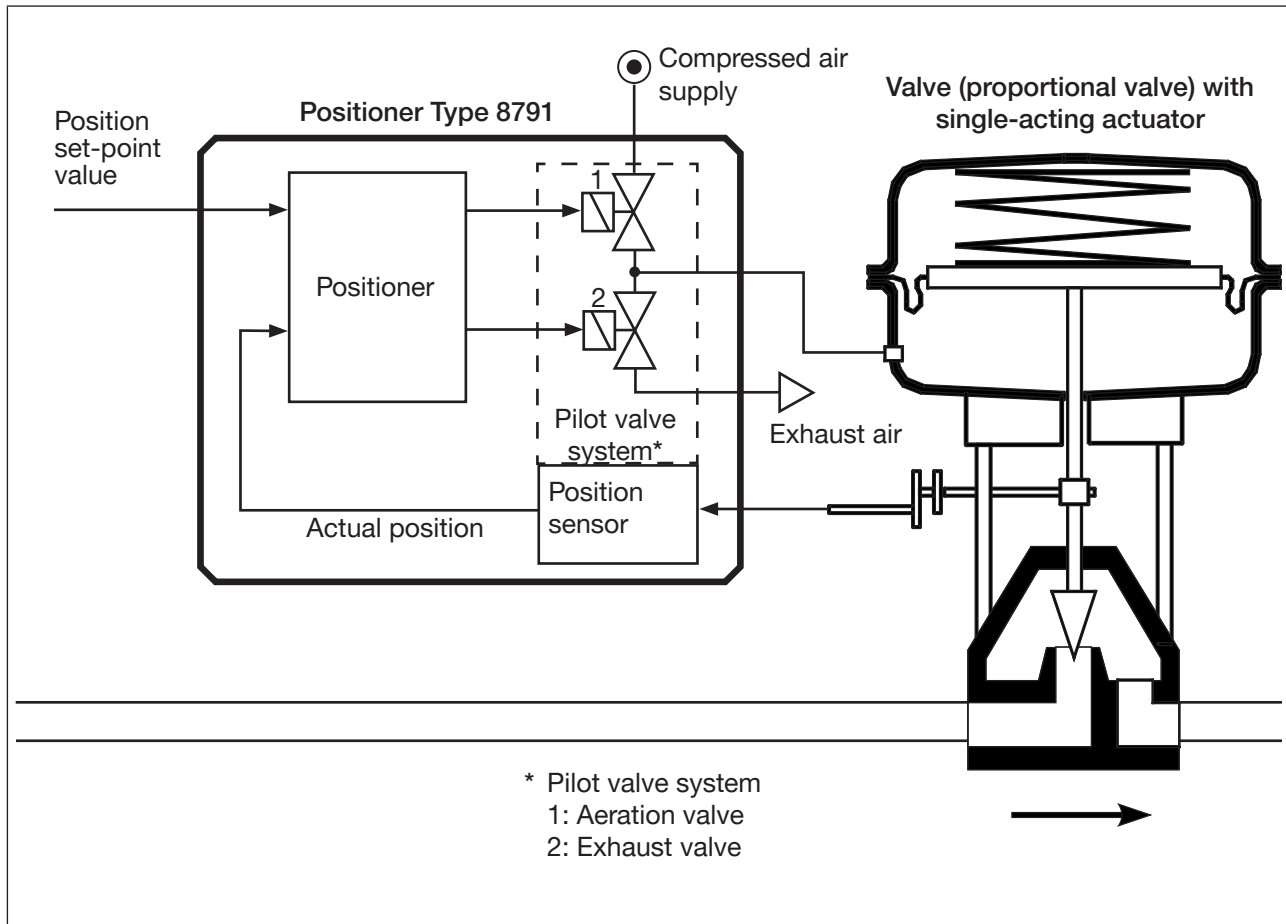

Fig. 2: Positioner Type 8791 functional diagram



For the remote variant, the position sensor is connected directly to the valve outside of the positioner and is connected to this using a cable.

7.2 Position control function

The position sensor records the current position (*POS*) of the pneumatic actuator. This actual position is compared by the positioner to the set-point value (*CMD*) specified as the standard signal. If there is a control difference (X_{d1}), the actuator is aerated and vented via the pilot valve system. In this way, the position of the actuator is changed up to control difference 0. Z_1 is a disturbance.

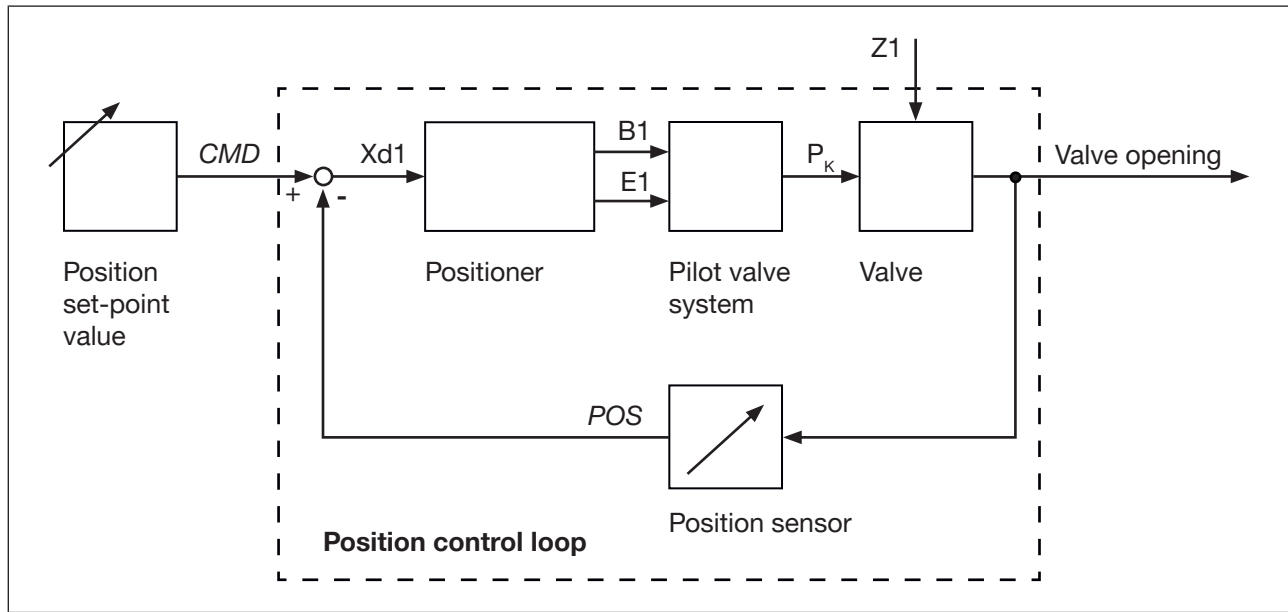

Fig. 3: Positioner signal flow plan

7.2.1 Schematic presentation of the position control

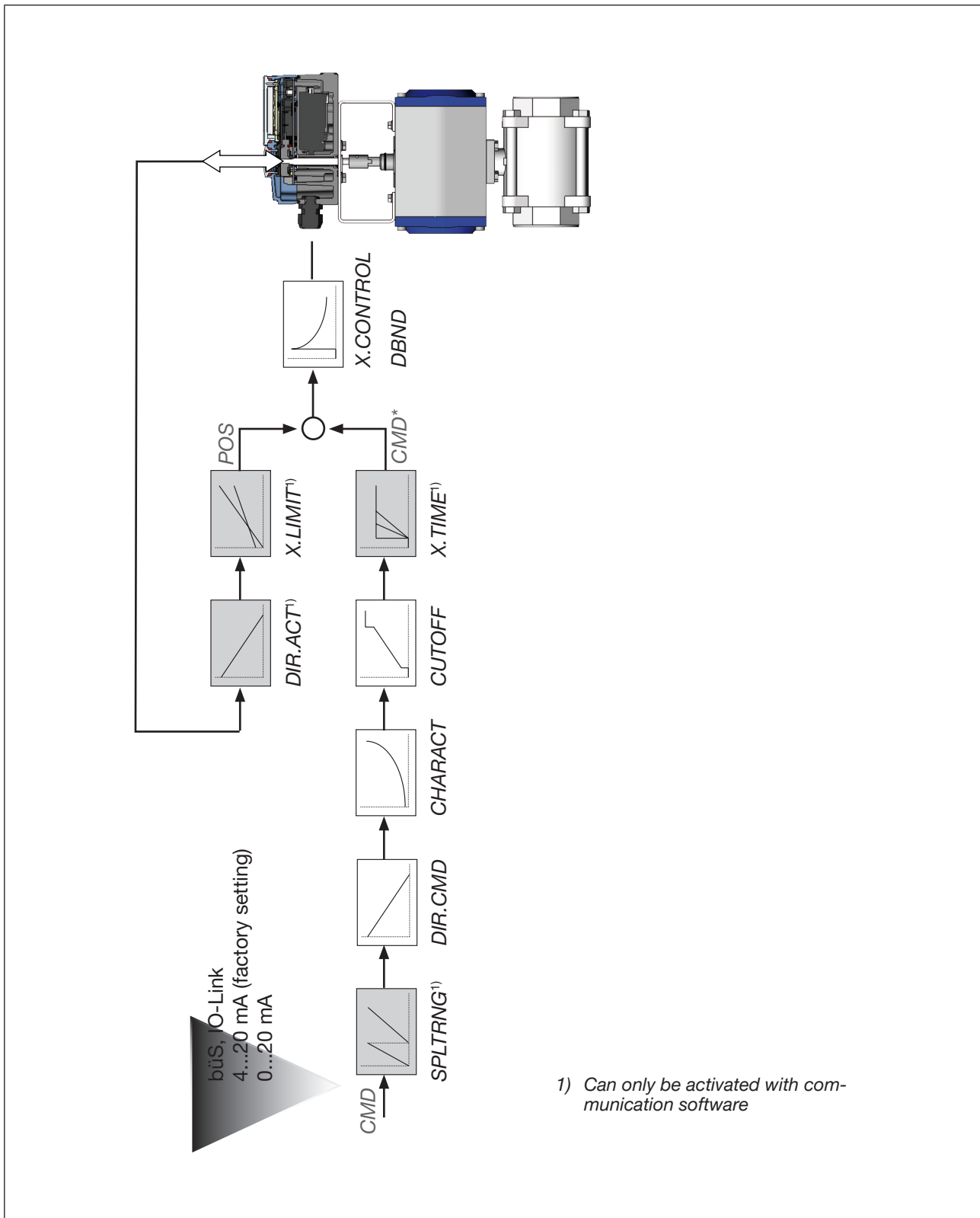

Fig. 4: Schematic presentation of the position control

7.2.2 Functions of the positioner software

Basic functions

- Activation with DIP switch
- Parameter setting with communication software

Function	Effect
Sealing function <i>CUTOFF</i>	Valve seals outside of the control range. Specification of the value (in %) from which the actuator is completely vented (at 0%) or aerated (at 100%) (see Chapter “9.3.2 DIP switch function”).
Characteristic correction <i>CHARACT</i>	Linearization of the operating characteristic can be executed (see Chapter “9.3.2 DIP switch function”).
Inversion of direction set-point value <i>DIR.CMD</i>	Reversal of the effective direction of the set-point value (see Chapter “9.3.2 DIP switch function”).

Table 2: Basic functions

Basic functions

- Activation with keys or communication software

Function	Effect
Standard signal ²⁾ <i>INPUT</i>	Selection of the standard set-point value signal
Automatic calibration of the positioner <i>X.TUNE</i>	
Factory reset <i>RESET</i>	Resetting to factory settings

Table 3: Basic functions

2) Can only be set with communication software.
Only for variants without fieldbus communication.

Auxiliary functions

- Activation and parameter setting with communication software

Function	Effect
Actuator inversion of direction <i>DIR.ACT</i>	Assignment of aeration status of the actuator chamber to the actual position.
Signal split range <i>SPLTRNG</i>	Standard signal in %, for which the valve runs through the whole stroke range.
Stroke limitation <i>X.LIMIT</i>	Limitation of mechanical stroke range
Actuating time limit <i>X.TIME</i>	Limit of control speed
Control parameters <i>X.CONTROL</i>	Parametrisation of the positioner
Safety position <i>SAFEPOS</i>	Definition of safety position
Cable break detection ³⁾ <i>SIG.ERROR</i>	Signal level error detection configuration
Digital input ³⁾ <i>BINARY.IN</i>	Digital input configuration
Analogue output ³⁾ <i>OUTPUT</i>	Configuration of the analogue output (variant)

Table 4: Auxiliary functions

3) Only for variants without fieldbus communication.

7.3 Positioner interfaces

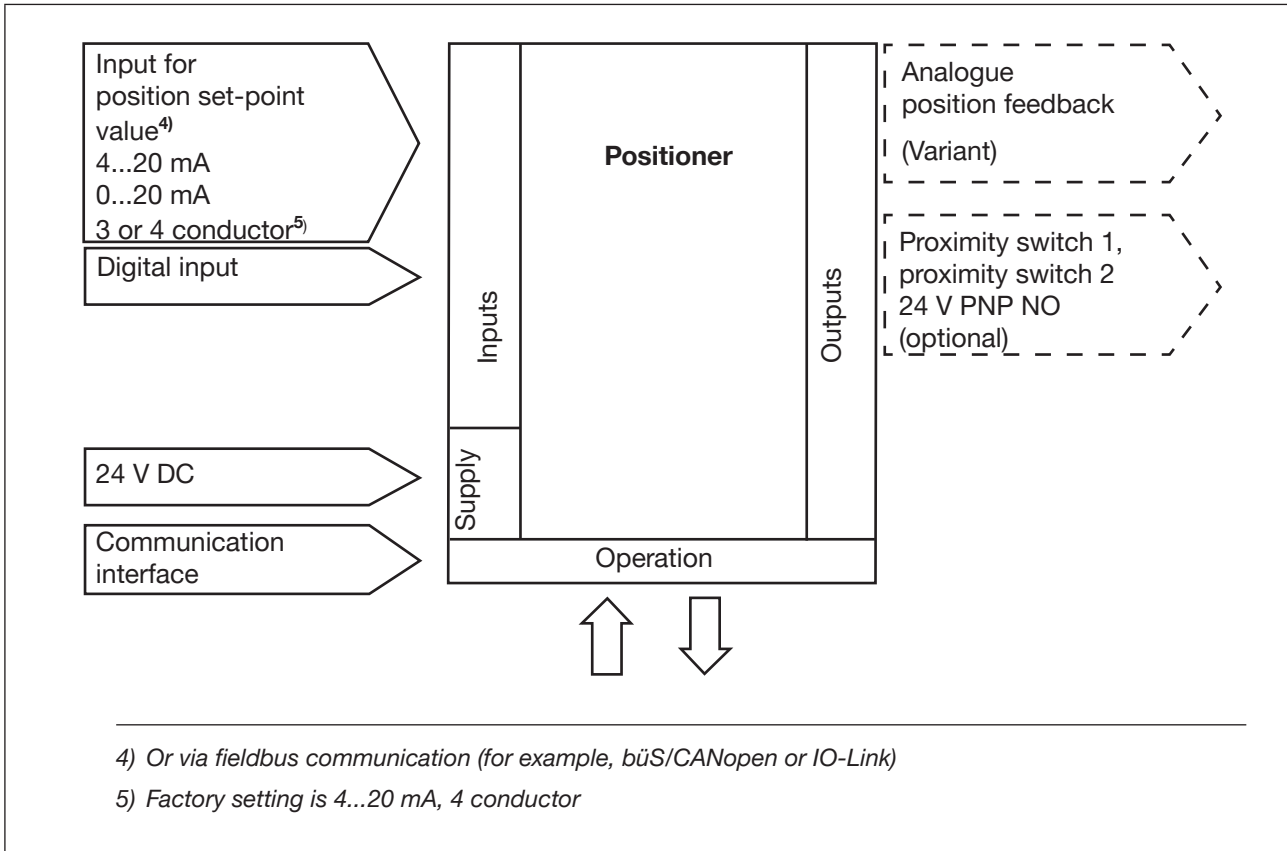

Fig. 5: Interfaces

! The positioner Type 8791 must be operated in the 3-conductor or 4-conductor connection type, i.e. the supply voltage (24 V DC) is separate from the set-point value signal.

- Input for position set-point value⁶⁾ (4...20 mA corresponds to 0...100%) (depending on the position of DIP switch 1).
- Digital input⁶⁾
When applying a voltage > 10 V safety position (*SAFEPOS*) becomes active, i.e. the valve is moved into safety position (factory setting, can be changed with communication software).
- Analogue position feedback⁶⁾ (Variant)
The position of the valve can be transferred to the PLC using an analogue 4...20 mA output (4...20 mA corresponds to 0...100%).

6) Only for variants without fieldbus communication.

8 TECHNICAL DATA

8.1 Standards and directives

The device complies with the relevant EU harmonisation legislation. In addition, the device also complies with the requirements of the laws of the United Kingdom.

The harmonised standards that have been applied for the conformity assessment procedure are listed in the current version of the EU Declaration of Conformity/UK Declaration of Conformity.

8.2 Operating conditions



WARNING!

Sunlight or temperature fluctuations may cause malfunctions or leaks.

- ▶ When using the device outdoors, protect it from adverse weather conditions.
- ▶ Ensure that ambient temperature does not exceed or drop below the permitted ambient temperature.

Ambient temperature	See type label
Degree of protection	IP65/IP67 ⁷⁾ to EN 60529 (only when cables or plugs and sockets connected correctly)
	<i>7) When using the positioner under IP67 conditions, the exhaust filter (see "Fig. 1: Structure, positioner Type 8791") must be removed and the exhaust air led to the dry area.</i>
Altitude	up to 2,000 m above sea level

8.3 Mechanical data

Dimensions	See data sheet
Materials	
Body material	Aluminium, plastic-coated
Other external parts	Stainless steel (V4A), PC, PE, POM, PTFE
Seal material	EPDM, NBR, FKM
Weight	approx. 1.0 kg

8.4 Type label

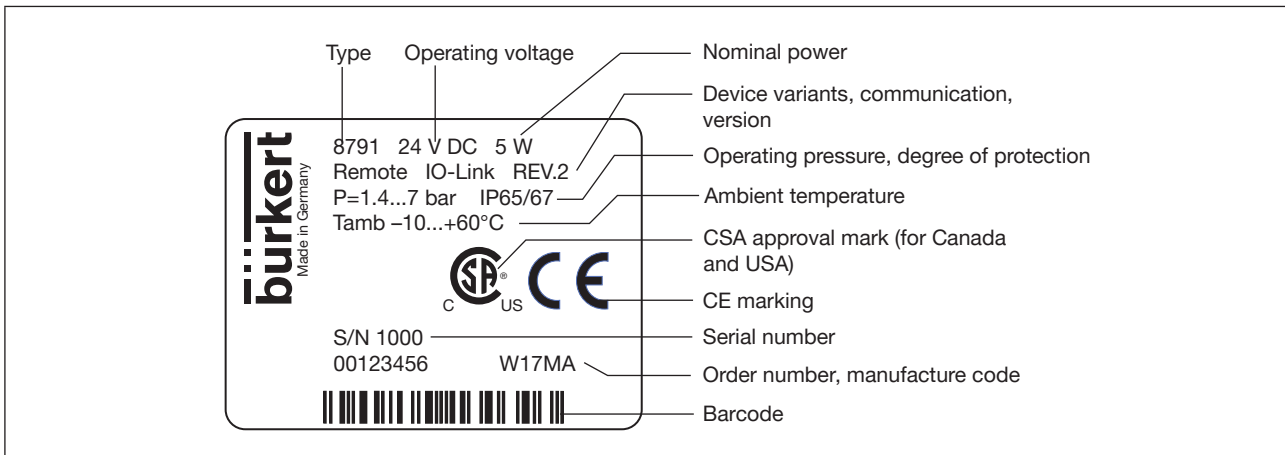

Fig. 6: Type label (example)

8.5 Electrical data

8.5.1 Electrical data, without fieldbus communication

Protection class	III according to DIN EN 61140 (VDE 0140-1)
Connections	2 cable glands (M20 x 1.5) with screw-type terminals 0.14...1.5 mm ² or circular plug-in connectors (M12, 8-pin)
Operating voltage	24 V DC ±25% max. residual ripple 10%
Current consumption	max. 190 mA
Power consumption	max. 3.5 W
Input resistance for set-point value signal	75 Ω at 0/4...20 mA/Resolution 12 bit
Analogue position feedback max. burden/load for current output 0/4...20 mA	560 Ω
Inductive proximity switches	100 mA current limit
Digital input	0...5 V = logical "0", 10...30 V = logical "1" (Invert the logic with software) (Input current < 6 mA)
Communication interface	Connection to PC using USB bÜS interface set
Communication software	Bürkert Communicator

8.5.2 Electrical data, IO-Link

Protection class	III according to DIN EN 61140 (VDE 0140-1)
Connection	Circular plug-in connector M12 x 1, 5-pin, A-coded
Port Class A	
Operating voltage	24 V DC $\pm 25\%$ (according to specification)
Current consumption	max. 150 mA
Port Class B	
Operating voltage	
System supply (Pin 1+3)	24 V DC $\pm 25\%$ (according to specification)
Actuator supply (Pin 2+5) ⁸⁾	24 V DC $\pm 25\%$ (according to specification)
Current consumption	
System supply (Pin 1+3)	max. 50 mA
Actuator supply (Pin 2+5)	max. 120 mA
Total power consumption	max. 3.5 W

8) Actuator supply is galvanically isolated from the system supply in accordance with IEC 60664 and for electrical safety in accordance with SELV from IEC 61010-2-201

8.5.3 Electrical data, bÜS

Protection class	III according to DIN EN 61140 (VDE 0140-1)
Connection	Circular plug-in connector M12 x 1, 5-pin, A-coded
Operating voltage	24 V DC $\pm 25\%$
Current consumption	max. 150 mA
Total power consumption	max. 3.5 W

8.6 Pneumatic data

Control medium	Neutral gases, air quality classes acc. to ISO 8573-1
Dust content	Class 7, max. particle size 40 µm, Max. particle density 10 mg/m ³
Water content	Class 3, max. pressure dew point –20 °C or min. 10 °C below the lowest operating temperature
Oil content	Class X, max. 25 mg/m ³
Temperature range	0...+60 °C
Pressure range	1.4...7 bar
Air flow rate	
Universal air flow rate	50 l _N /min (at 1.4 bar ³) for aeration and venting
Single- and double-acting	150 l _N /min (at 6 bar ³) for aeration and venting
6 bar	Q _{Nn} = 100 l _N /min (according to definition with pressure drop from 7 to absolute)
Low air flow rate bar single-acting	Q _{Nn} = 7 l _N /min (according to definition with pressure drop from 7 to 6 absolute)
Connections	Internal thread G1/4

8.7 Safety end positions after failure of the electrical or pneumatic auxiliary power

The safety end position depends on the pneumatic connection of the actuator to the working ports A1 or A2.

Actuator type	Designation	Safety end positions after failure of the electrical auxiliary power	pneumatic auxiliary power
	single-acting Control function A	down → Pneumatic connection in accordance with "Fig. 7"	univ. air flow rate: down
		up → Pneumatic connection in accordance with "Fig. 8"	Low air flow rate: not defined
	single-acting Control function B	up → Pneumatic connection in accordance with "Fig. 7"	univ. air flow rate: up
		down → Pneumatic connection in accordance with "Fig. 8"	Low air flow rate: not defined
	double-acting Control function I	→ Pneumatic connection see "Fig. 9"	not defined
		up = lower chamber of the actuator on A2	
		down = upper chamber of the actuator on A2	

Table 5: Safety end positions

Pneumatic connection: description for "Table 5".

Single-acting actuators Control function A or B	Double-acting actuators Control function I
Connect working port A1 to the actuator Seal A2	Connect working port A2 to the actuator Seal A1
	Connect working ports A1 and A2 to the actuator Safety end positions: up = lower chamber on A2 down = upper chamber on A2

Fig. 7: Connection A1

Fig. 8: Connection A2

Fig. 9: Connection at control function I (SF)

MAN 1000402005 EN Version: E Status: RL (released | freigegeben) printed: 19.02.2026

8.8 Positioner factory settings

8.8.1 Functions that can be activated via DIP switch

Function	Parameters	Value
<i>CUTOFF</i>	Sealing function bottom Sealing function top	2% 98%
<i>CHARACT</i>	Characteristic correction	FREE ¹⁰⁾
<i>DIR.CMD</i>	Inversion of direction set-point value	Off

Table 6: Factory settings;

8.8.2 Functions that can be activated via the communication software

Function	Parameters	Value
<i>INPUT</i>	Setpoint input	4...20 mA, 4 conductor
<i>DIR.ACT</i>	Actuator inversion of direction	Off
<i>SPLTRNG</i> Function disabled	Signal split range bottom Signal split range top	0% 100%
<i>X.LIMIT</i> Function disabled	Stroke limitation bottom Stroke limitation top	0% 100%
<i>X.TIME</i> Function disabled	Actuating time open Actuating time close	(1 s) Values determined by <i>X.TUNE</i> (1 s) Values determined by <i>X.TUNE</i> After executing <i>RESET</i> : 1 s
<i>X.CONTROL</i>	Dead band Open amplification factor Close amplification factor	1.0% (1) Values determined by <i>X.TUNE</i> (1) Values determined by <i>X.TUNE</i> After executing <i>RESET</i> : 1
<i>SAFEPOS</i>	Safety position	0%
<i>SIG.ERROR</i> ¹¹⁾ Function disabled	Cable break detection set-point value	Disabled
<i>BINARY.IN</i> ¹¹⁾	Digital input function Digital input circuit function	Safety position Normally open contact
<i>OUTPUT</i> ¹¹⁾ (Variant)	Function Standard signal	Position (POS) 4...20 mA

Table 7: Factory settings

10) If there have been no changes to the communication software a linear characteristic is set with *FREE*.

11) Only for variants without fieldbus communication.

9 OPERATION

9.1 Safety instructions



WARNING!

Risk of injury due to improper operation.

Improper operation may result in injuries as well as damage to the device and its surroundings.

- ▶ The operating personnel must know and have understood the contents of the operating instructions.
- ▶ The safety instructions and the intended use must be observed.
- ▶ Only adequately trained personnel may operate the system/device.

9.2 Operating state



To be able to operate the DIP switch and keys, ensure that the on-site operating lock is not disabled/ blocked (factory setting): with communication software or fieldbus communication.

AUTOMATIC (AUTO)

Normal controlled operation is executed and monitored in AUTOMATIC operating state.

MANUAL

In MANUAL operating state, the valve can be manually opened or closed using the keys.

DIP switch 4 changes between the 2 operating states, AUTOMATIC and MANUAL (see Chapter [“9.3.2 DIP switch function”](#)).

9.3 Operating and display elements of the positioner



To be able to operate the DIP switch and keys, ensure that the on-site operating lock is not disabled/ blocked (factory setting): with communication software or fieldbus communication.

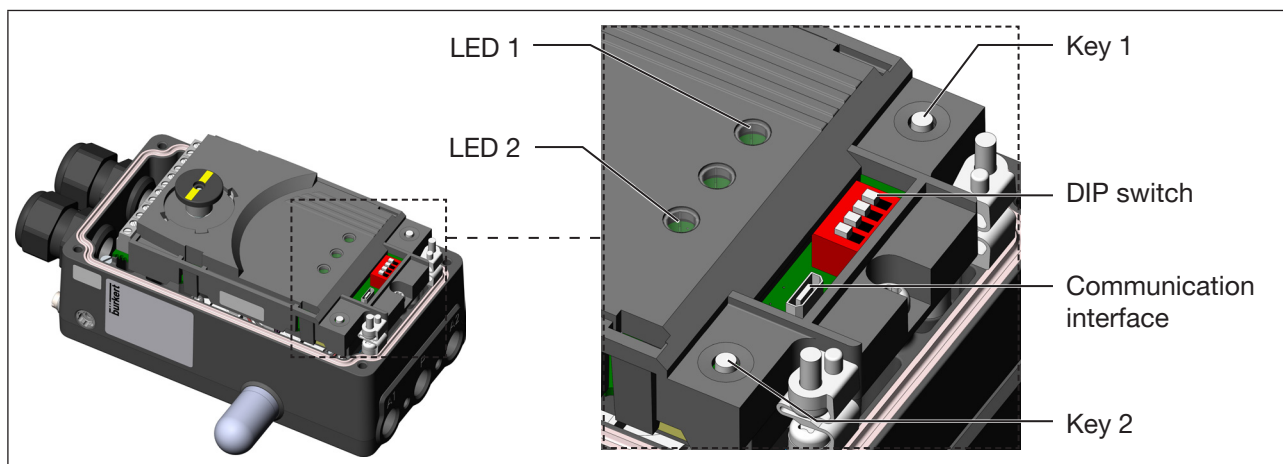

Fig. 10: Description of operating elements

The positioner is equipped with two keys, four DIP switches and two LEDs as display elements.

→ To operate the keys and DIP switch, unscrew the four screws on the housing cover and remove the housing cover.

9.3.1 Assignment of the keys



To be able to operate the DIP switch and keys, ensure that the on-site operating lock is not disabled/blocked (factory setting): with communication software or fieldbus communication.

The assignment of the two keys inside the actuator housing varies depending on the operating state (AUTOMATIC/MANUAL).

You can find the description of the operating states (AUTOMATIC/MANUAL) in Chapter “9.2 Operating state”.

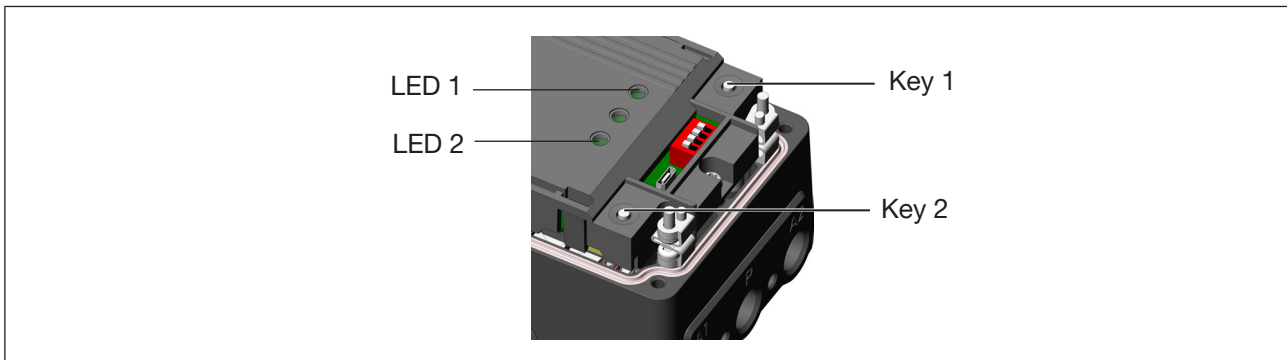

Fig. 11: Key description

→ To operate the keys and DIP switch, unscrew the four screws on the housing cover and remove the housing cover.

MANUAL operating state (DIP switch 4 set to ON):

Key	Function
1	Aeration (manual opening/closing of the actuator) ¹²⁾
2	Venting (manual opening/closing of the actuator) ¹²⁾
1 and 2 simul.	Press for longer than 10 s (< 30 s, LED 2 flashes at 5 Hz): device restart
	Longer than 30 s (LED 2 flashes at 10 Hz): Reset device to factory setting
¹²⁾ Dependent on the control function of the actuator.	

Table 8: MANUAL operating state key assignment

AUTOMATIC operating state (DIP switch 4 set to OFF):

Key	Function
1	Starting the X.TUNE function: press key for 5 s until LED 2 (green) flashes
2	-
1 and 2 simul.	Press for longer than 10 s (< 30 s, LED 2 flashes at 5 Hz): device restart
	Longer than 30 s (LED 2 flashes at 10 Hz): Reset device to factory setting

Table 9: AUTOMATIC operating state key assignment

9.3.2 DIP switch function



To be able to operate the DIP switch and keys, ensure that the on-site operating lock is not disabled/blocked (factory setting): with communication software or fieldbus communication.

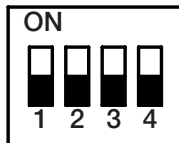

→ To operate the keys and DIP switch, unscrew the four screws on the housing cover and remove the housing cover.

DIP switch	Position	Function
1	ON	Reversal of the effective direction of the set-point value (<i>DIR.CMD</i>) (set-point value 20...4 mA = position 0...100%)
	OFF	Normal effective direction of the set-point value (set-point value 4...20 mA = position 0...100%)
2	ON	Sealing function active. The valve completely closes below 2% ¹³⁾ and opens above 98% of the set-point value (<i>CUTOFF</i>)
	OFF	No sealing function
3	ON	Correction characteristic for adjusting the operating characteristic (linearization of the operating characteristic, <i>CHARACT</i>) ¹⁴⁾
	OFF	Linear characteristic
4	ON	MANUAL operating state
	OFF	AUTO operating state

13) Factory setting, can be changed with communication software.
 14) The characteristic type can be changed with communication software

Table 10: DIP switch function



Notes on communication software:

The switch position of the DIP switch takes precedence over the communication software.

If the values of the sealing function (*CUTOFF*) or the correction characteristic (*CHARACT*) need to be changed with the communication software, the corresponding function needs to be active (DIP switch ON).

The effective direction of the set-point value (*DIR.CMD*) can only be changed with the DIP switch.

9.3.3 LED display

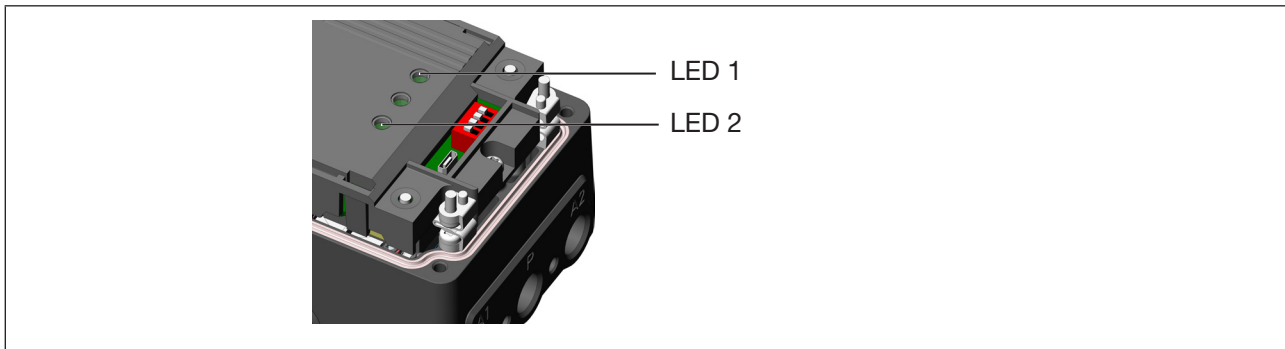

Fig. 12: LED display

LED 1 (RGB)	Display of device status and valve position
LED 2 (green)	Bus status display Feedback when pressing the keys to start functions <ul style="list-style-type: none"> • X.TUNE • device restart • Factory reset

9.3.4 Status indicator

LED 1 (RGB) shows the device status.

The user can set the following LED operation mode to display the device status and valve position:

- NAMUR operation mode
- Valve mode
- Valve mode and warnings (factory setting)
- Fixed colour
- LED off

The LED operation mode and valve position colours can be set using the Bürkert Communicator.

IO-Link:

The LED operation mode and valve position colours can also be set using an acyclic IO-Link parameter (see parameter list).



You can find the description for setting the LED operation mode in the operating instructions in Chapter [“10.2.10 Setting LED operation mode, device status”](#).

9.3.4.1 Valve mode

Displays in valve mode:

- Valve position: open, in between, closed
- Device status: failure

Valve position	Valve position State, colour	Device status: failure State, colour	
open	is lit yellow ¹⁵⁾	flashes red	alternately with yellow ¹⁵⁾
in between	is lit white ¹⁵⁾¹⁶⁾	flashes red	alternately with white ¹⁵⁾¹⁶⁾
closed	is lit green ¹⁵⁾	flashes red	alternately with green ¹⁵⁾

Table 11: Valve mode

9.3.4.2 Valve mode + warnings

Displays in valve mode + warnings:

- Valve position: open, in between, closed
- Device status: failure, function check, outside the specification, maintenance requirement (according to NAMUR)

Valve position		Device status
	State, colour	Normal operation
open	is lit yellow ¹⁵⁾	--
in between	is lit white ¹⁵⁾¹⁶⁾	--
closed	is lit green ¹⁵⁾	--

Table 12: Valve mode + warnings, normal operation

If several device statuses exist simultaneously, the highest priority device status is displayed.

Valve position	Device status				
	Failure	Function check	Outside the specification	Maintenance required	
	State, colour	State, colour	State, colour	State, colour	
open	flashes red	flashes orange	flashes yellow	flashes blue	alternately with yellow ¹⁵⁾
in between	flashes red	flashes orange	flashes yellow	flashes blue	alternately with white ¹⁵⁾¹⁶⁾
closed	flashes red	flashes orange	flashes yellow	flashes blue	alternately with green ¹⁵⁾

Table 13: Valve mode + warnings, device status

The LEDs briefly go off between colour changes for warning messages.

For localisation, the colours only display as flashes.

15) Factory setting, selectable colours for valve position: off, white, green, blue, yellow, orange, red

16) From firmware A.1.6

9.3.4.3 NAMUR operation mode

LED1 shows the device status.

The display elements change colour in line with NAMUR NE 107.

If several device statuses exist simultaneously, the device status with the highest priority is displayed. The priority is based on the severity of the deviation from controlled operation (red LED = failure = highest priority).

Status indicator in line with NE 107, issue 2006-06-12			
Colour	Colour code	Status	Description
Red	5	Failure, error or fault	Due to a malfunction in the device or its periphery, normal operation is not possible.
Orange	4	Function check	Work is being carried out on the device, which means that normal operation is temporarily not possible.
Yellow	3	Outside the specification	The environment conditions or process conditions for the device are not within the specified range.
Blue	2	Maintenance required	The device is in normal operation, but one function will soon be restricted. → Perform device maintenance
Green	1	Diagnostics active	Device is in error-free operation. Status changes are highlighted in colour. Messages are sent via any fieldbus that may be connected.

Table 14: Description of colour

9.3.5 Status LED, green

LED 2 (green) shows the following.

Colour	State	Description
Green	is not lit	IO-Link communication inactive ¹⁷⁾
	flashes	IO-Link communication active ¹⁷⁾
	flashes at 5 Hz	Feedback when pressing key 1 (start X.TUNE) or key 1+2 (device restart) > 5 s
	flashes at 10 Hz	Feedback when pressing keys 1+2 (reset device to factory setting) > 30 s

Table 15: LED 2, green

¹⁷⁾ Variant IO-Link only

9.4 Error notifications

9.4.1 Notifications on device status: Out of specification

Message	Description	Measure
Temperature warning limit exceeded	Ambient temperature is too high	Reduce ambient temperature Contact Bürkert Service if problem persists
Temperature warning limit undershot	Ambient temperature is too low	Increase ambient temperature
Voltage is above the warning limit	Supply voltage is too high	Check supply voltage
Voltage is below the warning limit	Supply voltage is too low	Check supply voltage
CMD cable break	Cable break in the set-point value signal. The message is parameterisable	Check signal line of set-point value

Table 16: Messages

9.4.2 Messages: Actuator is moving to safety position

Message	Description	Measure
Excess temperature detected	Device temperature too high for operation	Reduce ambient temperature Contact Bürkert Service if problem persists
Low temperature detected	Device temperature too low for operation	Increase ambient temperature
Overvoltage detected	Supply voltage too high for device operation	Check supply voltage
Undervoltage detected	Supply voltage failure, or supply voltage too low for device operation	Check supply voltage. Contact Bürkert Service if problem persists
Persistent memory unusable: defective or not available	Reading or writing error of internal data storage EEPROM	Restart the device. Contact Bürkert Service if problem persists
BüS event: producer(s) not found	Assigned external büS producer cannot be found	Check signal to büS partner
BüS event: bus connection lost/not available	büS network cannot be found	Check büS network
BüS event: producer is not operational	Producer not operational in this state	Check büS producer
BüS event: a device is using the same address	Another büS participant is using the same address	Assign a unique address to the device and büS participant

IO-Link errors	No valid process data was received	- Check connection to the IO-Link master - Check whether valid set-point values can be sent via the IO-Link interface to the device
X.TUNE error occurred	The last X.TUNE was not successful	-Check compressed air supply -Execute X.TUNE again
Actuator supply failed	The actuator supply voltage is too low. Only for IO-Link	Check actuator supply voltage
POS. monitor	The target position has not been reached. The message is parameterisable	-Execute X.TUNE -Check compressed air supply
CMD cable break	Cable break in the set-point value signal. The message is parameterisable	Check signal line of set-point value

Table 17: Messages

10 FUNCTIONS

The positioner Type 8791 has different basic and auxiliary functions that can be configured and parameterised via the DIP switch or communication software.

10.1 Basic functions

The following basic functions can be activated (*CUTOFF* and *CHARACT*) or changed (*DIR.CMD*) via the DIP switch.

The parameters for the sealing function (*CUTOFF*) and characteristic correction (*CHARACT*) are set with the communication software.

Function	Description	DIP switch	OFF	ON
Inversion of direction set-point value <i>DIR.CMD</i>	Effective direction between input signal and position set-point value	1	rising	falling
Sealing function <i>CUTOFF</i>	Sealing function for positioners	2	Sealing function off	Sealing function on
Characteristic correction <i>CHARACT</i>	Selection of the transfer characteristic between input signal and stroke (correction characteristic)	3	Linear characteristic	Correction characteristic

Table 18: DIP switch basic functions

The following basic functions can be activated or changed with keys or the communication software.

Function	Description	Factory setting
Standard signal ¹⁸⁾ <i>INPUT</i>	Input of the standard signal for the set-point value setting default	4...20 mA, 4 conductor
Factory reset <i>RESET</i>	Resetting to factory settings	
Automatic calibration of the positioner <i>X.TUNE</i>	Automatic adjustment of the positioner to the respective operating conditions	

Table 19: Basic functions

18) Can only be set with communication software.

10.1.1 *DIR.CMD* - Inversion of direction of the positioner set-point value

This function sets the effective direction between the input signal (*INPUT*) and the position set-point value of the actuator.

Factory setting: DIP switch OFF (rising)

DIP switch	Position	Function
1	ON	Reversal of the effective direction of the set-point value (<i>DIR.CMD</i>) (20...4 mA corresponds to 0...100 %), dropping
	OFF	Normal effective direction of the set-point value (set-point value 4...20 mA corresponds to position 0...100%), increasing

Table 20: *DIP switch 1*



The effective direction (*DIR.CMD*) can only be changed with DIP switch 1 in the positioner.

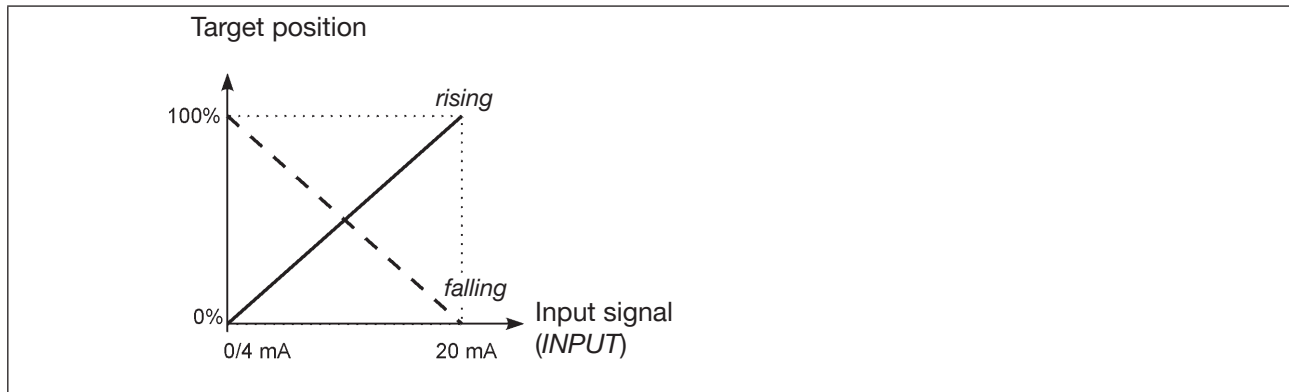

Fig. 13: *Diagram DIR.CMD*

10.1.2 CUTOFF - Sealing function for the positioner

This function ensures that the valve is tightly closed outside the control range.
Closed-loop control mode resumes with hysteresis of 1%.

Factory setting: DIP switch 2 to OFF (no sealing function)

DIP switch	Position	Function
2	ON	Sealing function active. The valve completely closes below 2% ¹⁹⁾ and opens above 98% of the set-point value (<i>CUTOFF</i>)
	OFF	No sealing function

Table 21: DIP switch 2

The limits for the position set-point value in per cent can be changed with the communication software.

! The switch position of the DIP switch in the positioner takes precedence over the communication software, i.e. sealing function (*CUTOFF*) settings which are changed with the communication software are only active if DIP switch 2 is set to ON in the positioner.

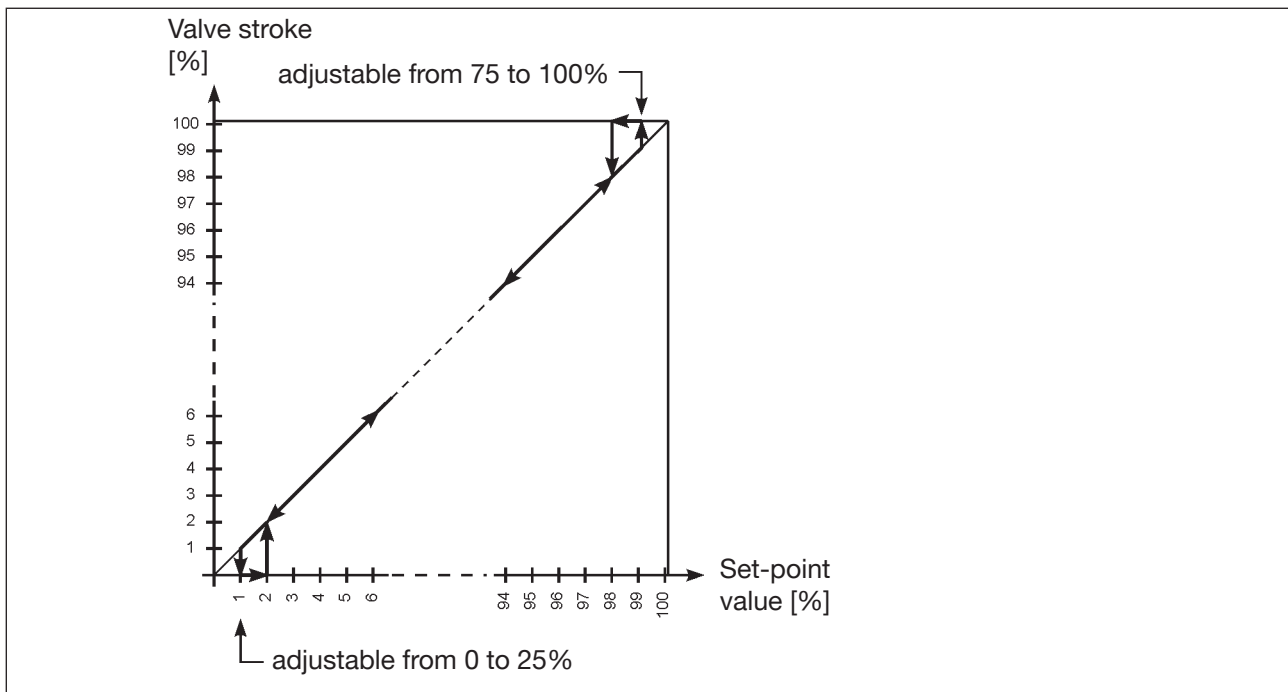

Fig. 14: CUTOFF diagram

19) Factory setting, can be changed using communication software.

10.1.3 **CHARACT** - Characteristic correction between the input signal (position set-point value) and stroke

Characteristic (client-specific characteristic)

This function enables a transfer characteristic with regard to the set-point value (position set-point value) and valve stroke for correcting the flow or operating characteristic.



The transfer characteristic can only be changed with communication software.

Factory setting: DIP switch 3 OFF (linear)

DIP switch	Position	Function
3	ON	Correction characteristic for adjusting the operating characteristic (linearization of the operating characteristic, <i>CHARACT</i>) ²⁰⁾
	OFF	Linear characteristic

Table 22: DIP switch 3



The switch position of the DIP switch in the positioner takes precedence over the communication software, i.e. settings of the correction characteristic (*CHARACT*) which are changed with the communication software are only active if DIP switch 3 is set to ON in the positioner.

Characteristics that can be selected with the communication software:

Characteristic curve	Description
Linear	Linear characteristic
1:25	Equal percentage characteristic 1:25
1:33	Equal percentage characteristic 1:33
1:50	Equal percentage characteristic 1:50
25:1	Inverse equal percentage characteristic 25:1
33:1	Inverse equal percentage characteristic 33:1
55:1	Inverse equal percentage characteristic 55:1
FREE	User-defined, freely programmable characteristic via supporting points

Table 23: Characteristic selection

²⁰⁾ The characteristic type can only be changed with communication software

The flow characteristic $k_v = f(s)$ indicates the flow rate of a valve, expressed by the k_v value, as a function of the stroke s of the actuator spindle. It is determined by the shape of the valve seat and the seat seal. Two types of flow characteristics are generally realised: the linear and the equal percentile.

With linear characteristics, equal stroke changes are apportioned the same k_v value changes dk_v .

$$(dk_v = n_{lin} \cdot ds).$$

With an equal percentage characteristic, a change in stroke ds corresponds to an equal percentage change in the k_v value.

$$(dk_v/k_v = n_{equal\ per} \cdot ds).$$

The operating characteristic $Q = f(s)$ shows the relationship between the volume flow Q in the installed valve and the stroke s . The properties of the pipelines, pumps and consumers are included in this characteristic. It therefore has a different shape to the flow characteristic.

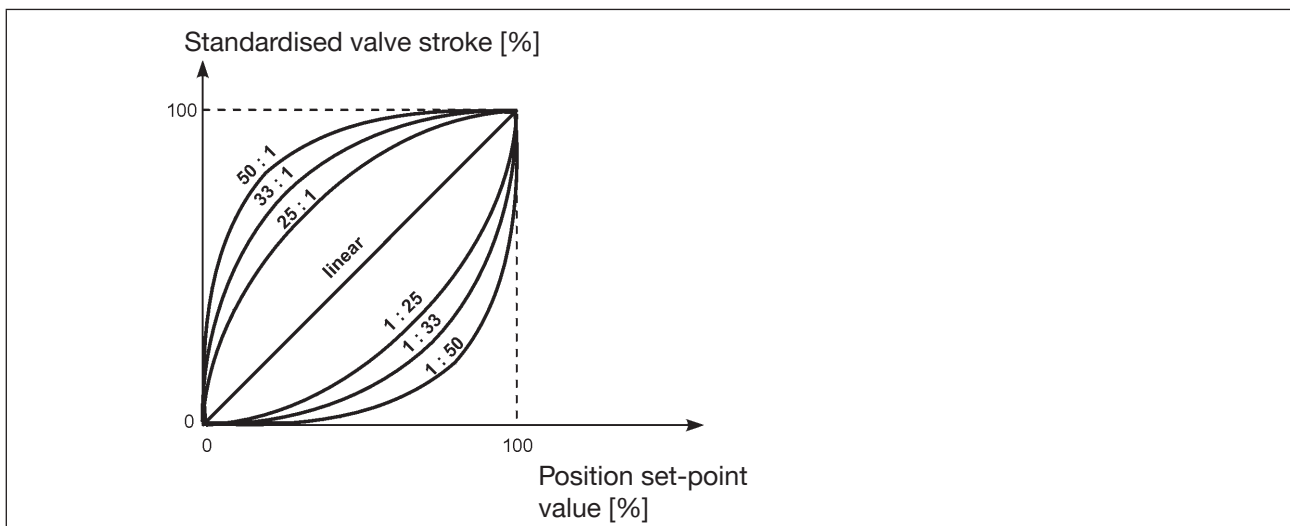

Fig. 15: Characteristic curve

In the case of positioning for closed-loop controls, special requirements are usually placed on the course of the operating characteristic, e.g. linearity. For this reason, it is occasionally necessary to correct the operating characteristic in an appropriate manner. For this purpose, a transmission element is provided in the positioner, which ensures various characteristics. These are used to correct the operating characteristic.

Equal percentage characteristics 1:25, 1:33, 1:50, 25:1, 33:1 and 50:1 as well as a linear characteristic can be set. In addition, it is possible to freely programme a characteristic curve via supporting points.

Input of the freely programmable characteristic

The characteristic is defined via 21 supporting points which are evenly distributed over the set-point range from 0 to 100%. Their spacing is 5%. A freely selectable stroke (setting range 0...100%) can be assigned to each supporting point. The difference between the stroke values of two adjacent supporting points must not be greater than 20%.

Example of a programmed characteristic

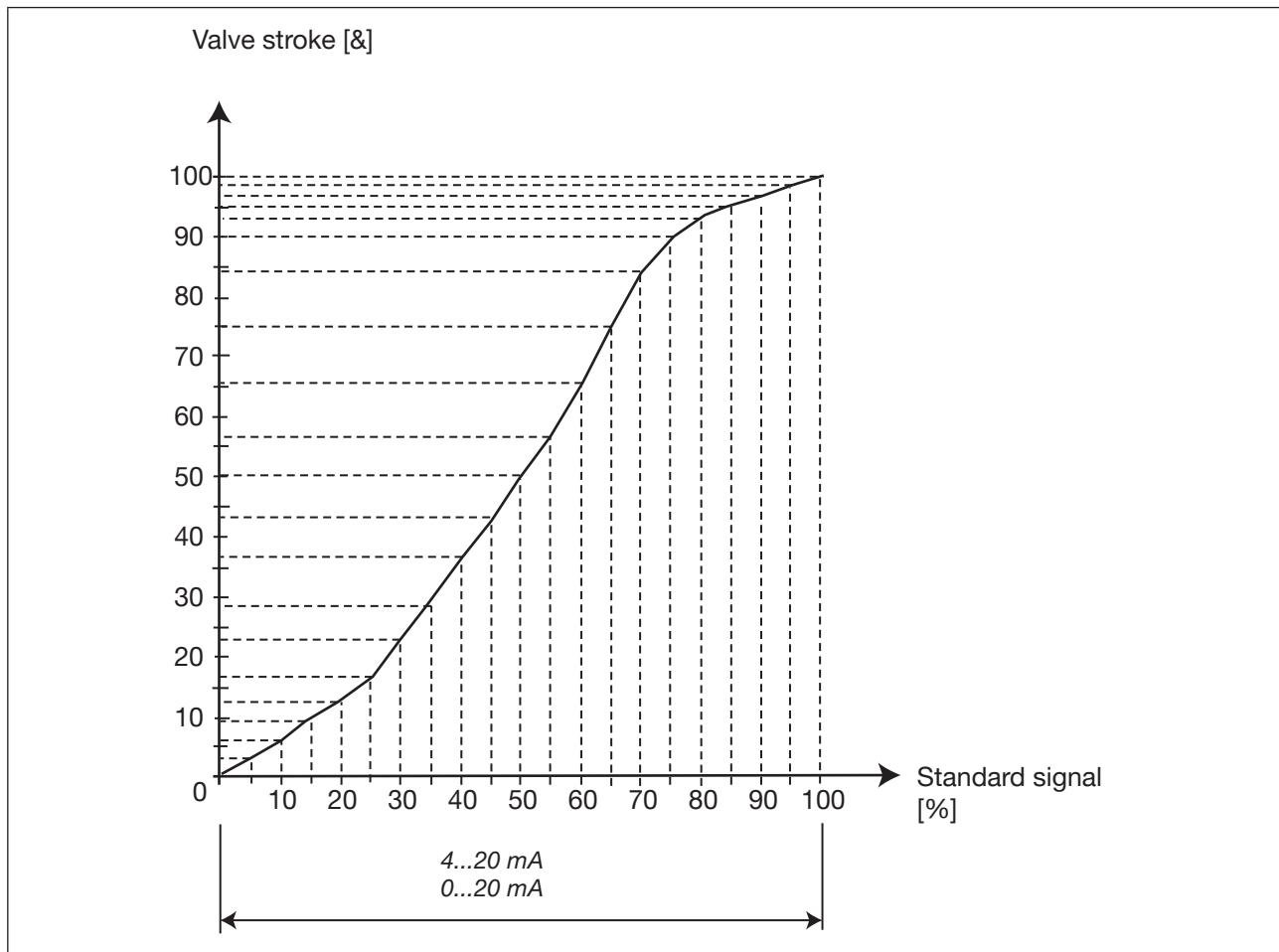

Fig. 16: Example of a programmed characteristic

10.1.4 INPUT - Input of standard signal (only variant without fieldbus communication)

This function is used to set the input signal for the set-point value.

Factory setting: 4...20 mA, 4 conductor

Other settings: 4...20 mA, 3 conductor
0...20 mA, 4 conductor
0...20 mA, 3 conductor

10.1.5 **RESET/FACTORY RESET -** Reset device to factory settings

This function resets the positioner to the factory settings.

10.1.6 **X.TUNE -** Automatic calibration of the positioner to the respective operating conditions



For a functional inspection of the positioner, the *X.TUNE* function must be executed to adapt the positioner to the local conditions.



WARNING!

During execution of the *X.TUNE* function, the valve automatically moves from its current position.

- ▶ *Never execute X.TUNE* when a process is running.
- ▶ Take appropriate measures to prevent the system/positioner from being operated unintentionally.

NOTE!

Avoid incorrect controller adjustment due incorrect pressure supply or activated operating medium pressure.

- ▶ **Always** execute *X.TUNE* in case of pressure supply (pneumatic auxiliary power) present in later operation.
- ▶ Ideally, execute the *X.TUNE* function **without** operating medium pressure to prevent interference as a result of flow forces.



To execute *X.TUNE* the positioner must be in AUTOMATIC operating state (DIP switch 4 = OFF).

→ Select **automatic calibration of the positioner**.

→ Start *X.TUNE* by pressing the **Next** button.

The progress of *X.TUNE* is displayed in the communication software:

If automatic adaptation has ended, a message appears.

The changes are automatically adopted after the *X.TUNE* function is successfully completed in the memory (EEPROM) of the positioner.

10.2 Auxiliary functions

The following auxiliary functions can be configured and parameterised with the communication software:

Function	Description
Actuator inversion of direction <i>DIR.ACT</i>	Assignment of aeration status of the actuator chamber to the actual position
Signal split range <i>SPLTRNG</i>	Signal split range: input signal in % for which the valve runs through the whole stroke range.
Stroke limitation <i>X.LIMIT</i>	Limitation of mechanical stroke range
Actuating time limit <i>X.TIME</i>	Limit of control speed
Control parameters <i>X.CONTROL</i>	Parametrisation of the positioner
Safety position <i>SAFEPOS</i>	Entry of safety position
Cable break detection ²¹⁾ <i>SIG.ERROR</i>	Signal level error detection configuration
Digital input ²¹⁾ <i>BINARY.IN</i>	Activation of digital input
Analogue output ²¹⁾ <i>OUTPUT</i>	Configuration of outputs (only with additional printed circuit board for analogue feedback or digital outputs)

Table 24: Auxiliary functions

21) Only for variants without fieldbus communication.

10.2.1 *DIR.ACT* - Actuator inversion of direction

This function sets the effective direction between the pressurisation state of the actuator and the actual position.

Factory setting: off (rising)

Rising: Direct effective direction (vented → 0%; aerated 100%)

dropping: Inverse effective direction (vented → 100%; aerated 0%)

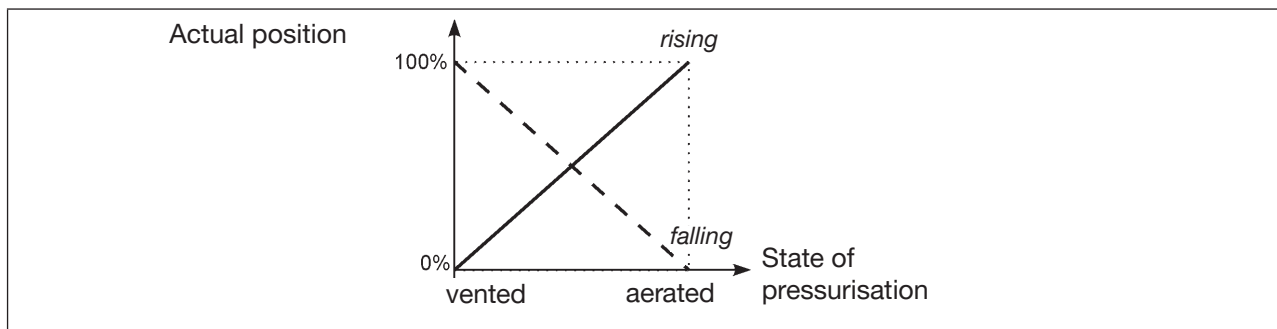

Fig. 17: *Diagram DIR.ACT*

10.2.2 *SPLTRNG* - Signal split range

Minimum and maximum value of the input signal in % for which the valve runs through the whole stroke range.

Factory setting: signal split range bottom = 0%; signal split range top = 100%

Signal split range bottom: Input of the minimum value of input signal in %:
Setting range: 0...75%

Signal split range top: Input of the maximum value of the input signal in %
Setting range: 25...100%

This function limits the position set-point value range of the positioner by setting a minimum and maximum value. This makes it possible to split a used standard signal range (4...20 mA, 0...20 mA) into several positioners (without or with overlap). In this way, several valves can be used alternately, or simultaneously for overlapping set-point value ranges, as proportional valves.

Splitting of one standard signal range into two set-point value ranges:

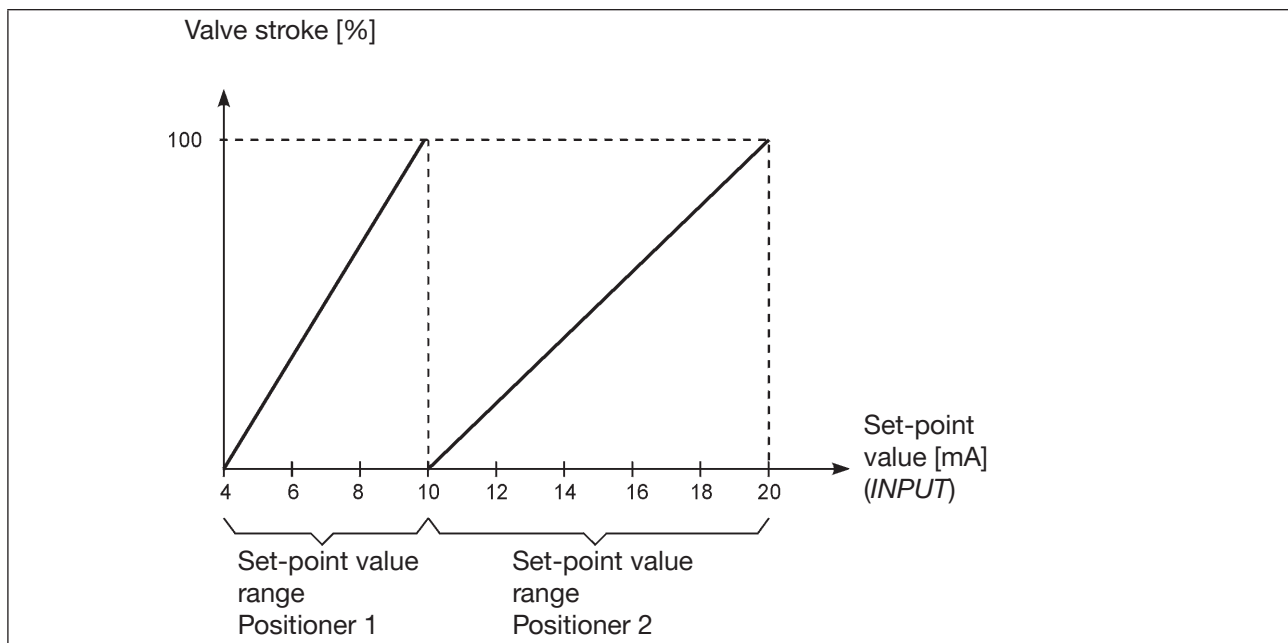

Fig. 18: *SPLTRNG* diagram

10.2.3 X.LIMIT - Stroke limitation

This function limits the (physical) stroke to predetermined % values (bottom and top). The stroke range of the limited stroke is thereby set to 100%. If the limited stroke range is exceeded during operation, negative actual positions or actual positions greater than 100% are displayed.

Factory setting: Bottom stroke limitation= 0%, Top stroke limitation = 100%

Setting ranges:

Bottom stroke limitation: 0...50% of the total stroke

Top stroke limitation: 50...100% of the total stroke

The minimum distance between the bottom and top stroke limitation is 50%, i.e. when a value is entered whose minimum distance is < 50%, the other values are automatically adapted.

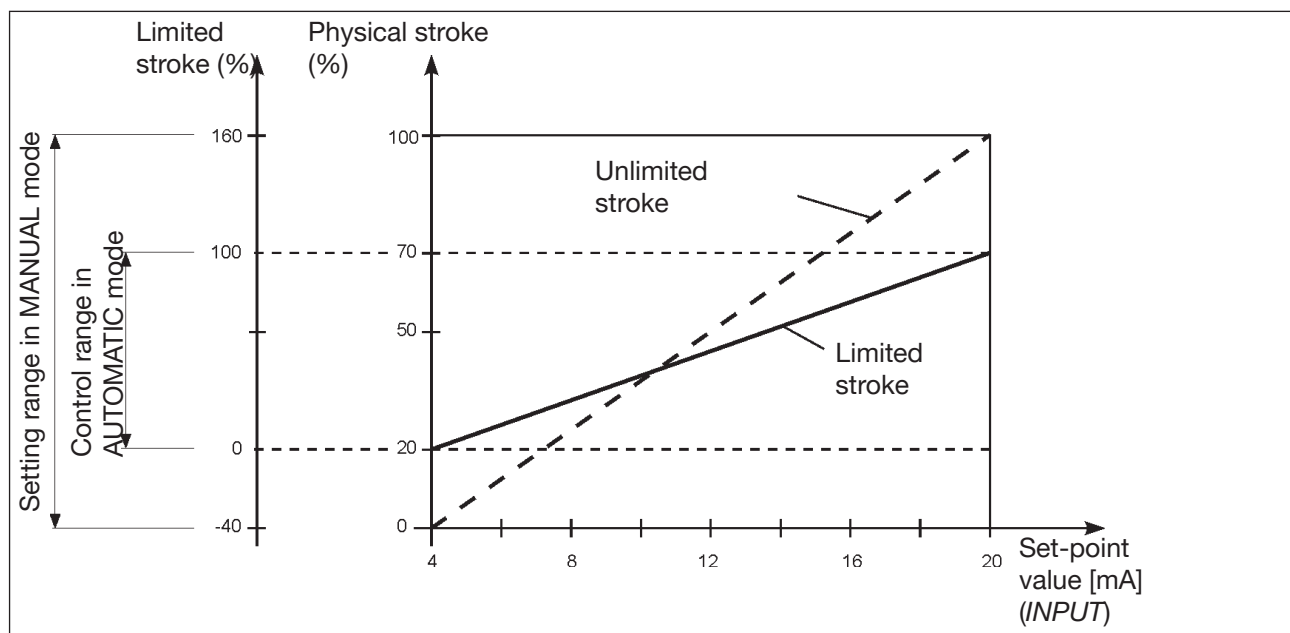

Fig. 19: Diagram X.LIMIT

10.2.4 X.TIME - Actuating time limit

This function can be used to set the opening and closing times for the entire stroke, and thus limit the control speeds.



When performing the *X.TUNE* function, the minimum opening and closing time are entered for the entire stroke for Open and Close. This facilitates movement at maximum speed.

Factory setting: factory-set values through the *X.TUNE* function

If the control speed is to be reduced, values can be entered for Open and Close which lie between the minimal values to be determined by *X.TUNE* and 60 s.

Actuating time Open: Opening time for the whole stroke (in seconds)
Setting range: 1...60 seconds

Actuating time close: Closing time for the whole stroke (in seconds)
Adjustment range: 1...60 seconds

Effect of a limit of the opening speed in the event of a spike in set-point value

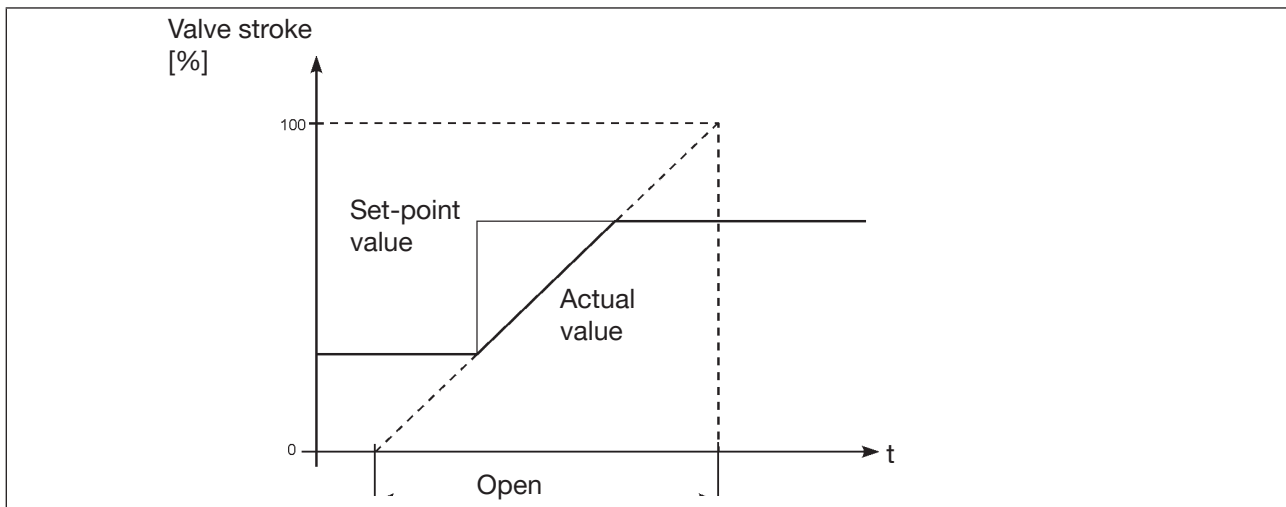

Fig. 20: Diagram X.TIME

10.2.5 X.CONTROL - control parameter of the positioner

This function sets the parameters of the positioner (dead band and amplification factors).

Dead band: Insensitivity range of the positioner

Input of the dead band in %, based on the scaled stroke range;

i.e. $X.LIMIT$ Stroke limitation top - $X.LIMIT$ Stroke limitation bottom (See auxiliary function $X.LIMIT$).

This function ensures that the controller does not respond until a certain control difference is reached. This function protects the solenoid valve in the positioner and the pneumatic actuator.



If, during the execution of $X.TUNE$, the control parameter ($X.CONTROL$) auxiliary function is in the main menu, the positioner dead band is determined automatically depending on the friction behaviour of the actuator. The value determined in this way is a guide value. It can be readjusted manually.

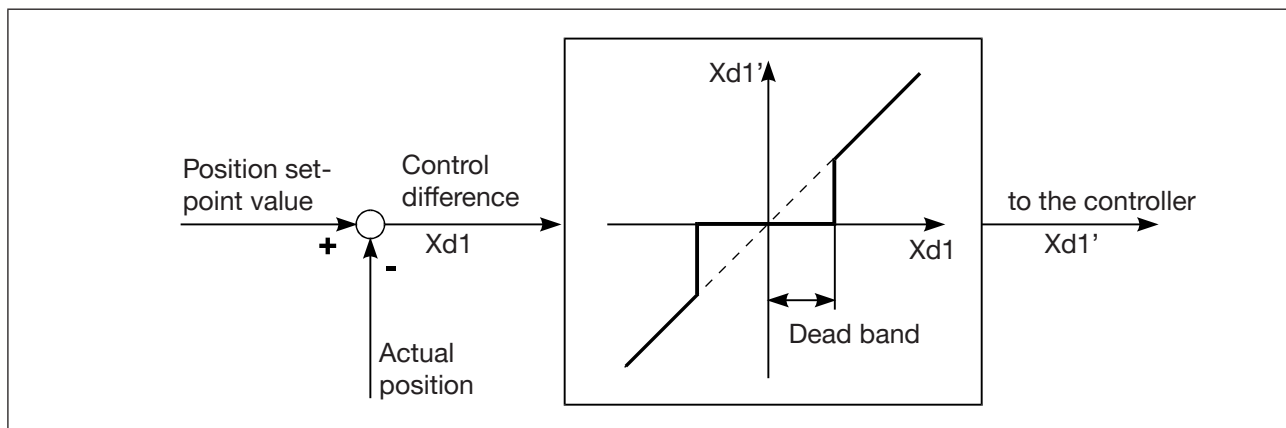

Fig. 21: Diagram X.CONTROL

Open/close amplification factor: Parameter of the positioner

Open amplification factor: Amplification factor of the positioner (for closing the valve)

Close amplification factor: Amplification factor of the positioner (for opening the valve)

10.2.6 SAFEPOS - Definition of safety position

This function is used to set the safety position of the actuator that is approached with defined signals.



The set safety position is only approached if there is a corresponding signal at the digital input (for configuration see digital input) ($BINARY.IN$) or when an error occurs. If the mechanical stroke range is limited with the stroke limit function ($X.LIMIT$), only safety positions within this limitation can be approached. This function is only executed in AUTOMATIC operating state.

10.2.7 **SIG.ERROR** - Configuring the cable break detection (only for variants without fieldbus communication)

The cable break detection function (*SIG.ERROR*) is used to detect an error on the set-point value signal.



Cable break detection can only be selected with 4...20 mA signal:
error with set-point value at ≤ 3.5 mA ($\pm 0.5\%$ of end value, hysteresis 0.5% of end value)

When selecting 0...20 mA, the cable break detection cannot be selected.

If cable break detection is enabled (error or outside of the specification), a signal error is displayed via LED 1 on the device.

Safety position when the cable break detection is enabled:

Active safety position (*SAFEPOS*) function

When an error is detected, the actuator moves to the position set under safety position.

Inactive safety position (*SAFEPOS*) function

When an error is detected, the actuator moves into the end position that it would take in de-energised state.

10.2.8 **BINARY.IN** - Configuring the digital input (only for variants without fieldbus communication)

The following settings can be configured:

- Approaching safety position
- Starting the *X.TUNE* function

Safety position

Digital input = 1 → Approaching safety position

Active safety position (*SAFEPOS*) function

The actuator moves to the position set under safety position.

Inactive safety position (*SAFEPOS*) function

The actuator moves into the end position that it would take in de-energised state.

Starting the *X.TUNE* function

Digital input = 1 → Start *X.TUNE*

10.2.9 OUTPUT (variant) - Configuring the analogue output (only for variants without fieldbus communication)

The analogue output (*OUTPUT*) function only appears in the function selection if the positioner has an analogue output (variant) or no parameters have been read in yet.

The analogue output can be used for feedback from the current position or from the set-point value at the control centre.

Function	Position (POS) Set-point value (CMD)	Issuing of the current position Issuing of the set-point value
Standard signal	4...20 mA 0...20 mA	Selection of the standard signal

10.2.10 Setting LED operation mode, device status

User level: installer

Factory setting: valve mode + warnings

Menu or function	Values or description
Device	
> General settings	
> Parameter	
> Status LED	
Operation mode	<input checked="" type="radio"/> NAMUR operation mode <input type="radio"/> Valve operation mode <input type="radio"/> Valve operation mode + warnings <input type="radio"/> Fixed colour <input type="radio"/> LED off

Setting LED operation mode, device status:

→ Status LED

→ Operation mode

Possible selection:

- NAMUR operation mode
- Valve operation mode
- Valve operation mode + warnings
- Fixed colour
- LED off

→ Choose operation mode.

The operation mode is set.

11 MOUNTING AND INSTALLATION



You can find the dimensions of the positioner and the different device variants in the data sheet.

11.1 Safety instructions



WARNING!

Risk of injury due to improper installation.

- ▶ Installation may be carried out by authorised technicians only and with the appropriate tools.

Risk of injury due to unintentional activation of the system and uncontrolled restart.

- ▶ Secure system against unintentional activation.
- ▶ Ensure a controlled restart after installation.

11.2 Mounting on a continuous valve with linear actuator according to NAMUR

The valve position is transmitted to the position sensor installed in the positioner via a lever (in accordance with NAMUR).

11.2.1 Attachment kit (in accordance with IEC 534-6) on linear actuators (order number 787215)

(Can be obtained from Bürkert as an accessory.)

No.	Pieces	Designation
1	1	NAMUR mounting bracket IEC 534
2	1	Hoop
3	2	Clamping piece
4	1	Driver pin
5	1	Conical roller
6a	1	NAMUR lever for stroke range 3–35 mm
6b	1	NAMUR lever for stroke range 35–130 mm
7	2	U-bolt
8	4	Hexagon bolt DIN 933 M8x20
9	2	Hexagon bolt DIN 933 M8x16
10	6	Spring lock washer DIN 127 A8
11	6	Washer DIN 125 B8.4
12	2	Washer DIN 125 B6.4
13	1	Spring VD-115E 0.70 x 11.3 x 32.7 x 3.5
14	1	Spring washer DIN 137 A6
15	1	Locking washer DIN 6799 - 3.2
16	3	Spring lock washer DIN 127 A6
17	3	Hexagon bolt DIN 933 M6x25
18	1	Hexagon nut DIN 934 M6
19	1	Square nut DIN 557 M6
21	4	Hexagon nut DIN 934 M8
22	1	Guide washer 6.2 x 9.9 x 15 x 3.5

Table 25: Attachment kit on linear actuators

11.2.2 Installation

WARNING!

Risk of injury due to improper installation.

- ▶ Installation may be carried out by authorised technicians only and with the appropriate tools.

Risk of injury due to unintentional activation of the system and uncontrolled restart.

- ▶ Secure system against unintentional activation.
- ▶ Ensure a controlled restart after installation.

Procedure:

- Mount the hoop (2) on the actuator spindle using the clamping pieces (3), hexagon bolts (17) and spring lock washers (16).

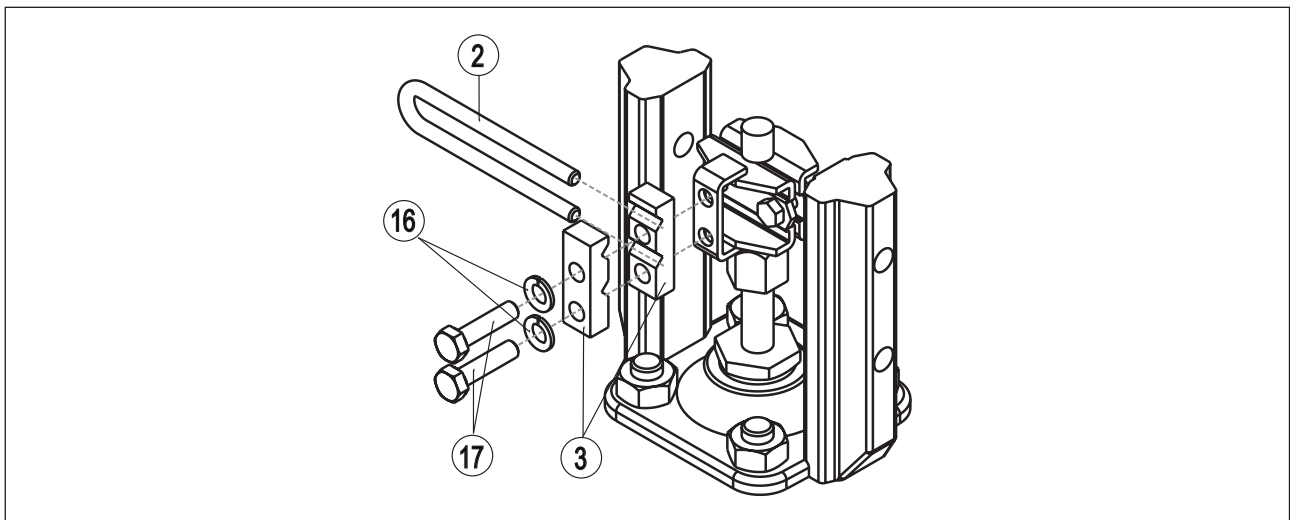

Fig. 22: Hoop installation

- Select a short or long lever according to the stroke of the actuator (see [“Table 25: Attachment kit on linear actuators”](#), no. 6a/6b).

- Assemble the lever (if not pre-assembled, see [“Fig. 23”](#)).

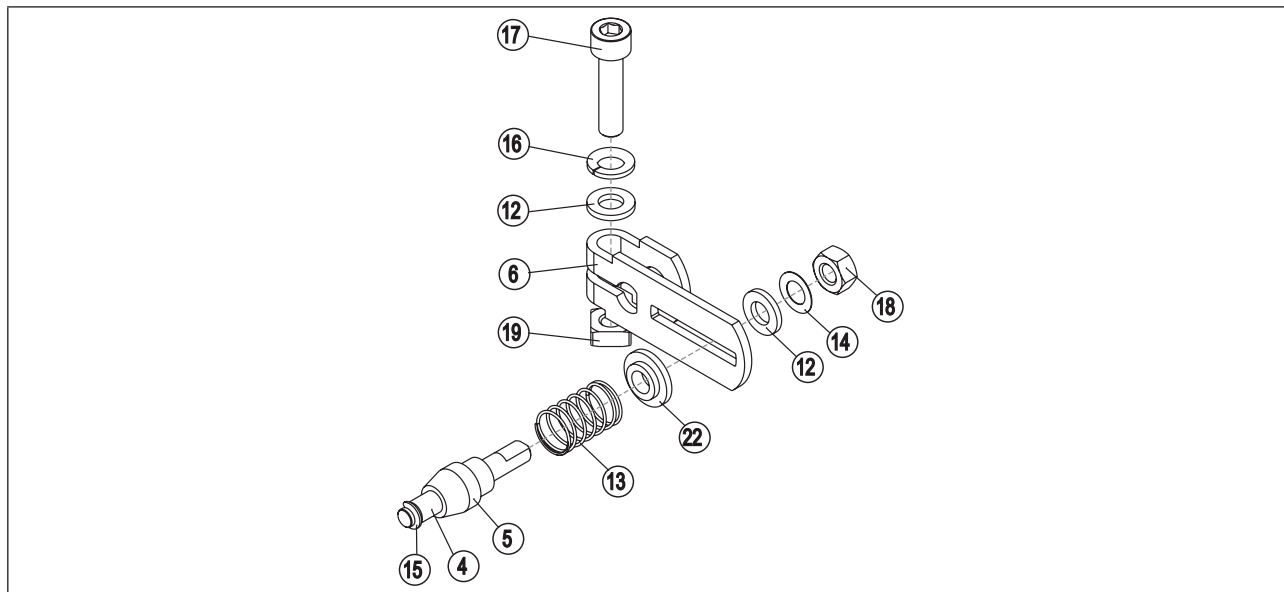

Fig. 23: Lever installation



The gap between the driver pin and the shaft should be the same as the actuator stroke. As a result, the lever has an ideal rotational range of 60° (see “Fig. 24”).

Position sensor angular range:

The maximum angular range of the position sensor is 180°.

Rotational range of the lever:

To ensure that the position sensor works with good resolution, the rotational range must be between 30° and 120°.

The scale printed on the lever is not relevant.

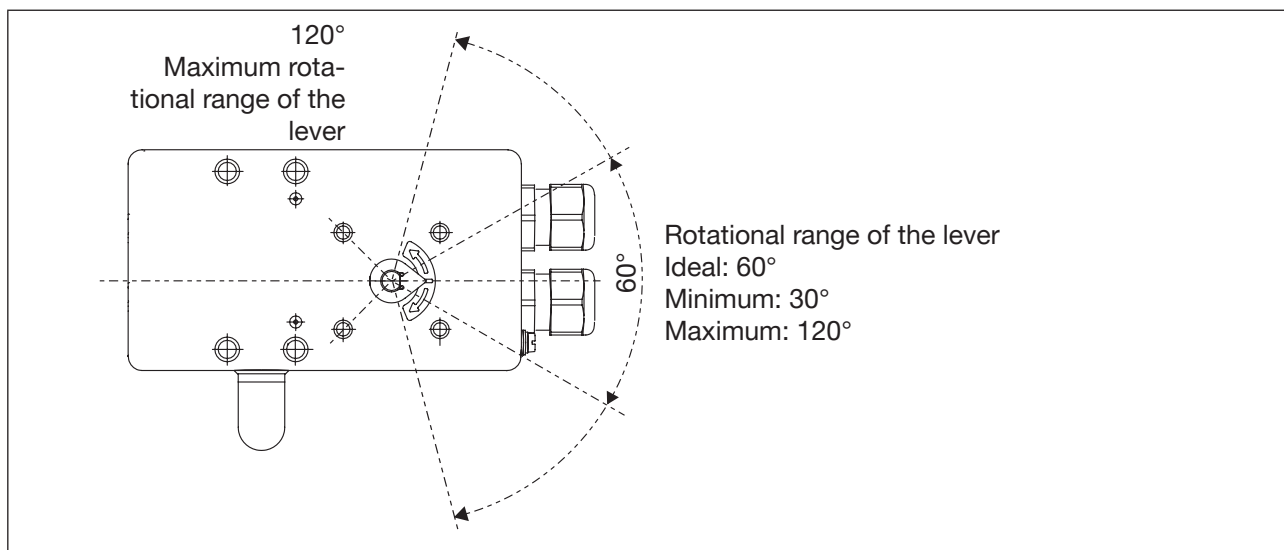

Fig. 24: Rotational range of the lever

→ Insert lever into the shaft of the positioner and tighten (17) and (19).

11.2.3 Attaching the mounting bracket

→ Attach the mounting bracket ① to the rear of the positioner using the hexagon bolts ⑨, the spring lock washers ⑩ and the washers ⑪ (see “Fig. 25”).

! Selection of the M8 thread used on the positioner depends on the actuator size.

→ To determine the correct position, hold the positioner with the mounting bracket on the actuator.

The conical roller on the lever of the **position sensor** in the hoop must be able to move freely along the entire stroke range of the actuator.

At 50% stroke, the lever position should be approximately horizontal (see Chapter “11.2.4 Aligning the lever mechanism”).

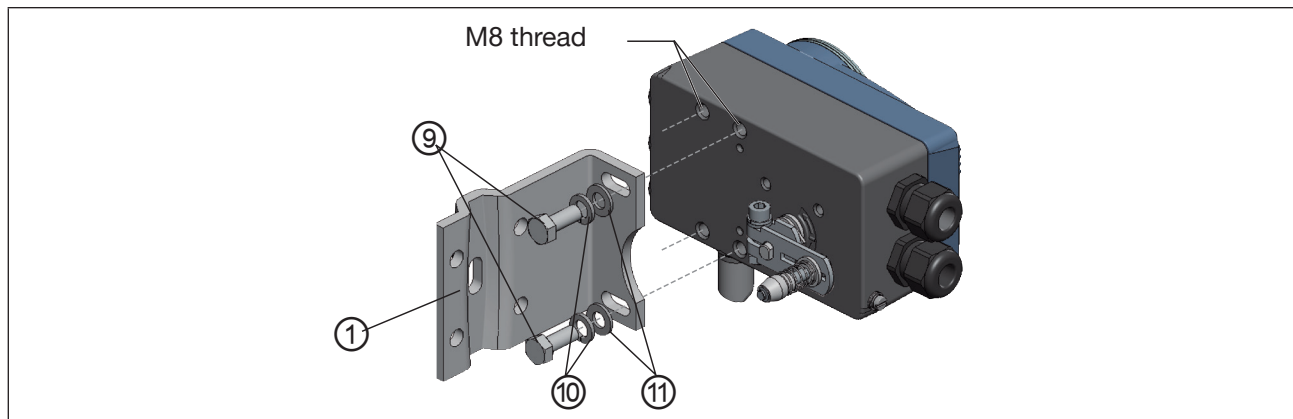

Fig. 25: Attaching the mounting bracket

Attaching the positioner with the mounting bracket for actuators with a cast frame:

→ Attach the mounting bracket to the cast frame using one or more hexagon bolts ⑧, the washers ⑪ and the spring lock washers ⑩ (see “Fig. 26”).

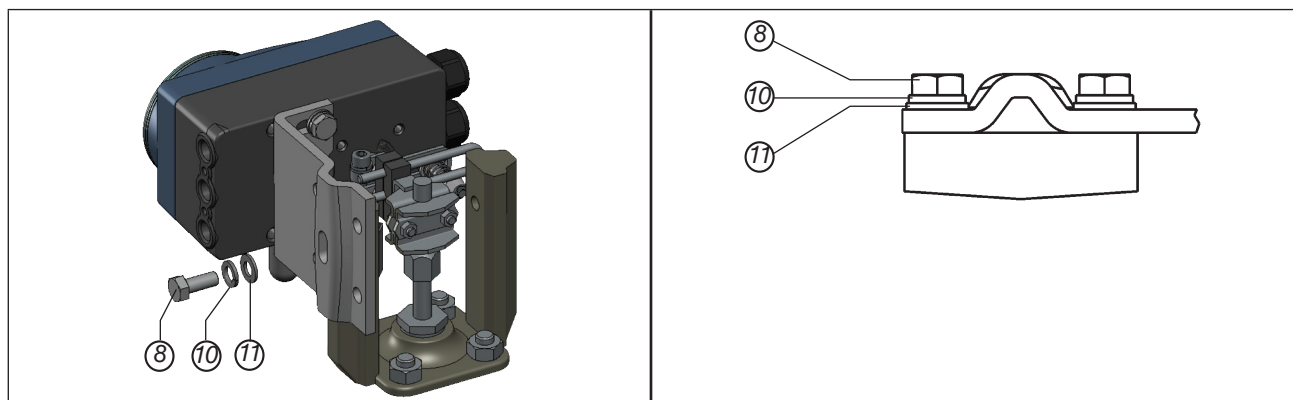

Fig. 26: Attaching the positioner with the mounting bracket; for actuators with a cast frame

Attaching the positioner with the mounting bracket for actuators with a columnar yoke:

→ Attach the mounting bracket to the columnar yoke using the U-bolt ⑦, the washers ⑪, the spring lock washers ⑩ and the hexagon nuts ② (see “Fig. 27”).

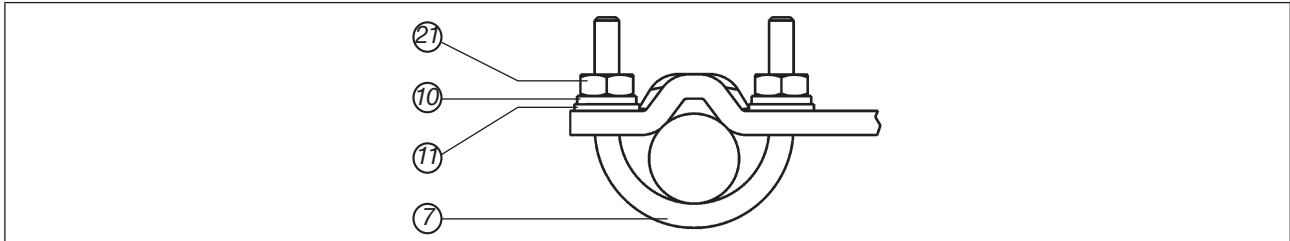

Fig. 27: Attaching the positioner with the mounting bracket; for actuators with a columnar yoke

11.2.4 Aligning the lever mechanism



The lever mechanism cannot be correctly aligned until the device has been electrically and pneumatically connected.

- Move the actuator in manual mode to half stroke (according to the scale on the actuator).
- Adjust the height of the positioner until the lever is horizontal.
- Fix the positioner in this position on the actuator.

11.3 Mounting on a continuous valve with rotary actuator

The shaft of the position sensor integrated into the positioner is directly connected to the shaft of the rotary actuator.

11.3.1 Attachment kit (in accordance with VDI/VDE 3845) on rotary actuator (Order number 787338)

(Can be obtained from Bürkert as an accessory.)

No.	Pieces	Designation
1	1	Adapter
2	2	Setscrew DIN 913 M4 x 10
3	4	Hexagon bolt DIN 933 M6 x 12
4	4	Spring lock washer B6
5	2	Hexagon nut DIN 985, M4

Table 26: Attachment kit on rotary actuators

Additional accessory parts:

The assembly bridge with fastening screws (in accordance with VDI/VDE 3845) can be obtained from Bürkert as an accessory under order number 770294.

11.3.2 Installation



WARNING!

Risk of injury due to improper installation.

- ▶ Installation may be carried out by authorised technicians only and with the appropriate tools.

Risk of injury due to unintentional activation of the system and uncontrolled restart.

- ▶ Secure system against unintentional activation.
- ▶ Ensure a controlled restart after installation.

Procedure:

- Specify the attachment position of the positioner:
 - Parallel to the actuator or
 - Rotated by 90° to the actuator.
- Determine the home position and the direction of rotation of the actuator.



Anti-twist safeguard:

Observe the spot face on the shaft.
One setscrew must lie on the spot face of the shaft as an anti-twist safeguard (see “Fig. 28”).

Angular range of the position sensor:

The maximum angular range of the position sensor is 180°.
The shaft of the positioner should only be used within this range.

- Insert adapter ① on to the shaft of the positioner and attach with two setscrews.
- Secure the setscrew with self-locking nuts.

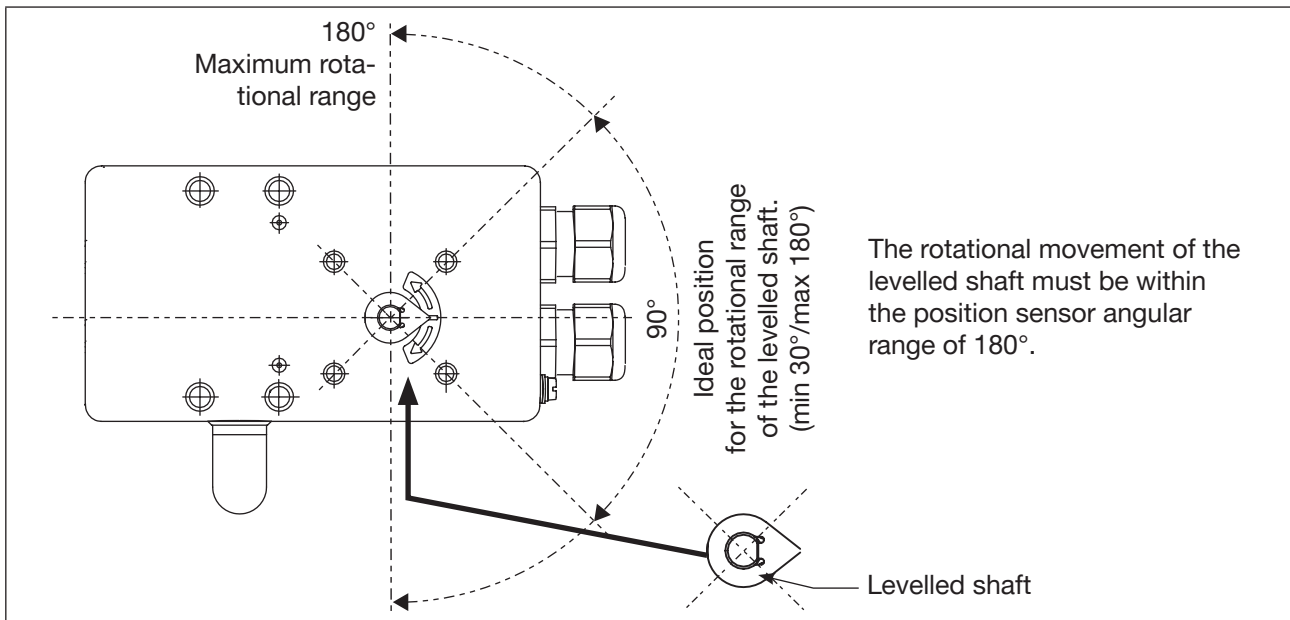

Fig. 28: Angular range/anti-twist safeguard

- Assemble the multi-part assembly bridge²²⁾ suitable for the actuator.
- Attach the assembly bridge to the positioner using four hexagon bolts ③ and spring lock washers ④ (see “Fig. 29”).

22) The assembly bridge consists of four parts, which can be adjusted to the actuator by varying the arrangement.

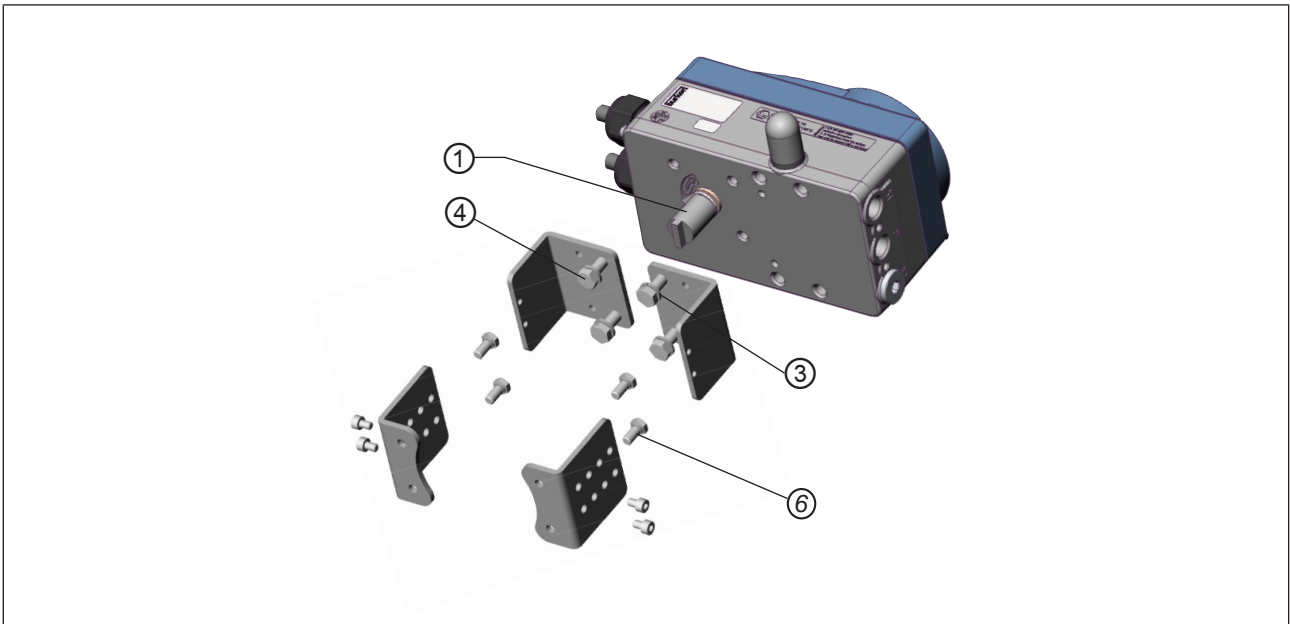

Fig. 29: Attaching assembly bridge (schematic representation)

→ Place the positioner with the assembly bridge on the rotary actuator and attach it using four hexagon bolts ⑥ (see “Fig. 30”).

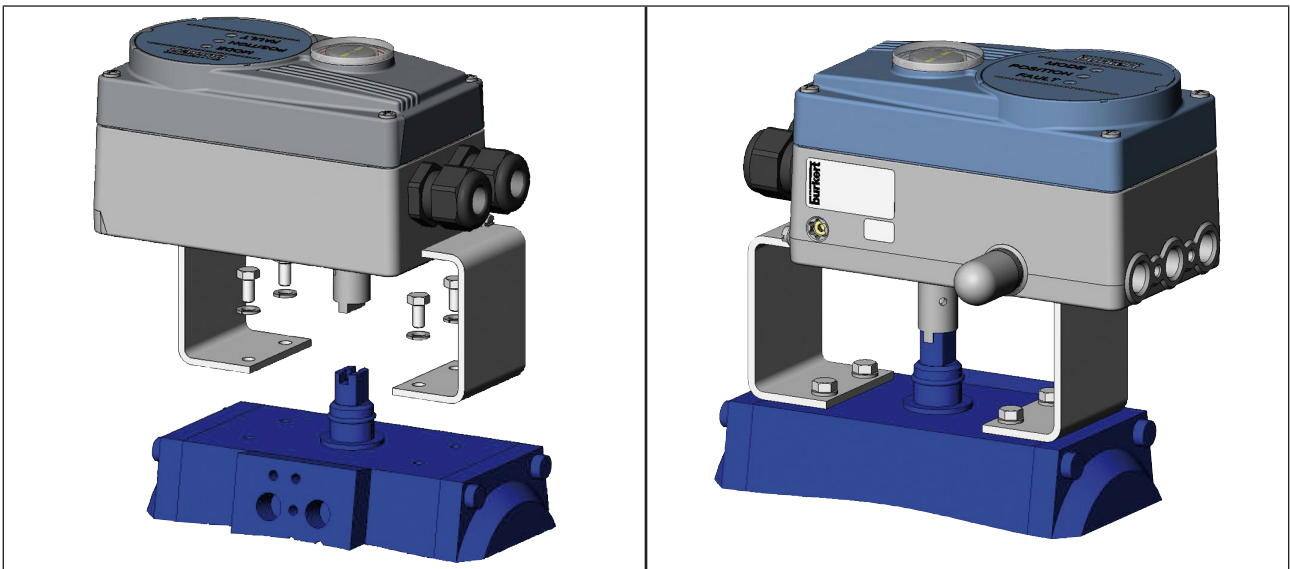

Fig. 30: Rotary actuator attachment

11.4 Remote operation with external position sensor

In this variant, the positioner does not have a position sensor in the form of an angle of rotation sensor but has an external remote sensor.

The Type 8798 remote sensor is connected using a serial digital interface.

11.4.1 Attachment accessories

There are two options for attaching the positioner in remote operation (see “Fig. 31”).

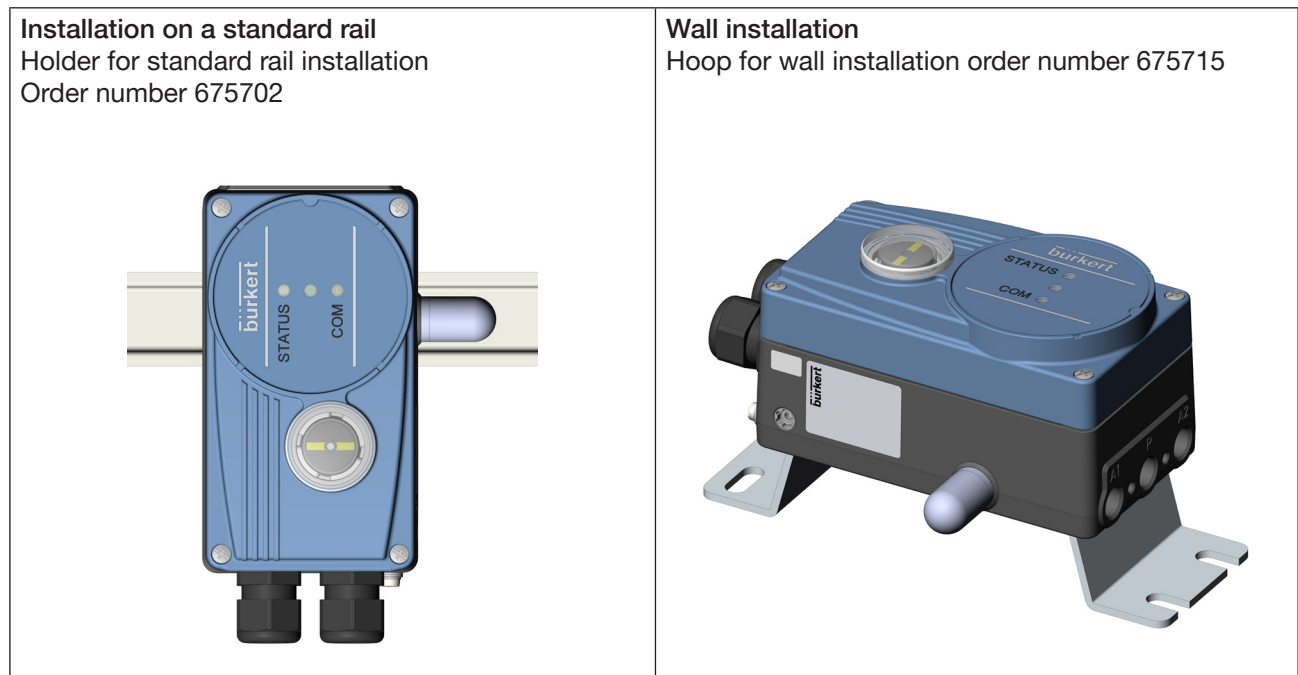

Fig. 31: Attachment types in remote operation

11.4.2 Connection and start-up of the remote sensor Type 8798



WARNING!

Risk of injury due to improper start-up.

- ▶ Start-up may be carried out by authorised technicians only and with the appropriate tools.

Risk of injury due to unintentional activation of the system and uncontrolled restart.

- ▶ Secure system against unintentional activation.
- ▶ Ensure a controlled restart after installation.

- Connect the four wires of the sensor cable to the screw-type terminals of the positioner intended for this (see Chapter "[13.3.6 Terminal assignment for external position sensor \(only for remote variant\)](#)").
- Mount the remote sensor on the actuator.
The proper procedure is described in the quickstart for the Type 8798 remote sensor.
- Pneumatically connect the positioner to the actuator.
- Connect compressed air to the positioner.
- Switch on the positioner supply voltage.
- Perform the *X.TUNE* function.

12 PNEUMATIC CONNECTION

12.1 Safety instructions

DANGER!

Risk of injury from high pressure in the system/device.

- ▶ Before working on the system or device, switch off the pressure and vent/empty the lines.

WARNING!

Risk of injury due to improper installation.

- ▶ Installation may be carried out by authorised technicians only and with the appropriate tools.

Risk of injury due to unintentional activation of the system and uncontrolled restart.

- ▶ Secure system against unintentional activation.
- ▶ Following installation, ensure a controlled restart.

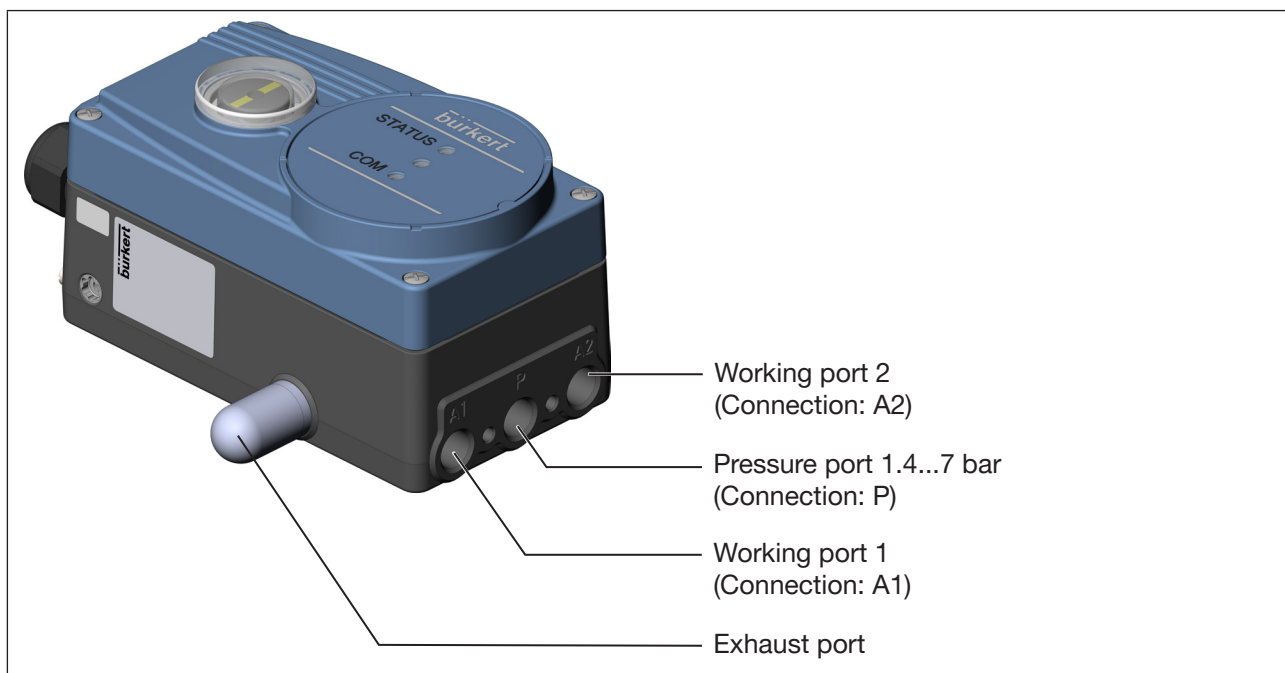

Fig. 32: Pneumatic installation, location of connections

Procedure:

→ Apply supply pressure (1.4...7 bar) to the pressure port P.

For single-acting actuators (control function A and B):

→ Connect working port (A1 or A2, depending on the desired safety end position) to the chamber of the single-acting actuator.

For safety end positions see Chapter [“8.7 Safety end positions after failure of the electrical or pneumatic auxiliary power”](#).

→ Seal the working ports that are not needed with a sealing plug.

For double-acting actuators (control function I):

→ Connect working ports A1 and A2 to the respective chamber of the double-acting actuator.

For safety end positions see Chapter [“8.7 Safety end positions after failure of the electrical or pneumatic auxiliary power”](#).



Important information for perfect control behaviour.

To prevent the control behaviour in the upper stroke range from being negatively influenced by a small pressure difference:

→ Keep the applied supply pressure at least 0.5...1 bar above the pressure that is required to move the pneumatic actuator into end position.

The control parameters calibrated with the *X.TUNE* function are not ideal for larger fluctuations.

→ Keep the supply pressure fluctuations as low as possible during operation (max. ± 10%).

13 ELECTRICAL INSTALLATION WITHOUT FIELDBUS COMMUNICATION

All electrical inputs and outputs of the device are not galvanically isolated to the supply voltage.

13.1 Safety instructions



DANGER!

Risk due to electric shock.

- ▶ Before working on the system or device, switch off the power supply and secure against reactivation.
- ▶ Observe any applicable accident prevention regulations and safety regulations for electrical devices.



WARNING!

Risk of injury due to improper installation.

- ▶ Installation may be carried out by authorised technicians only and with the appropriate tools.

Risk of injury due to unintentional activation of the system and uncontrolled restart.

- ▶ Secure system against unintentional activation.
- ▶ Following installation, ensure a controlled restart.

13.2 Electrical installation with circular plug-in connector

13.2.1 Designation of circular plug-in connector M12, 8-pin

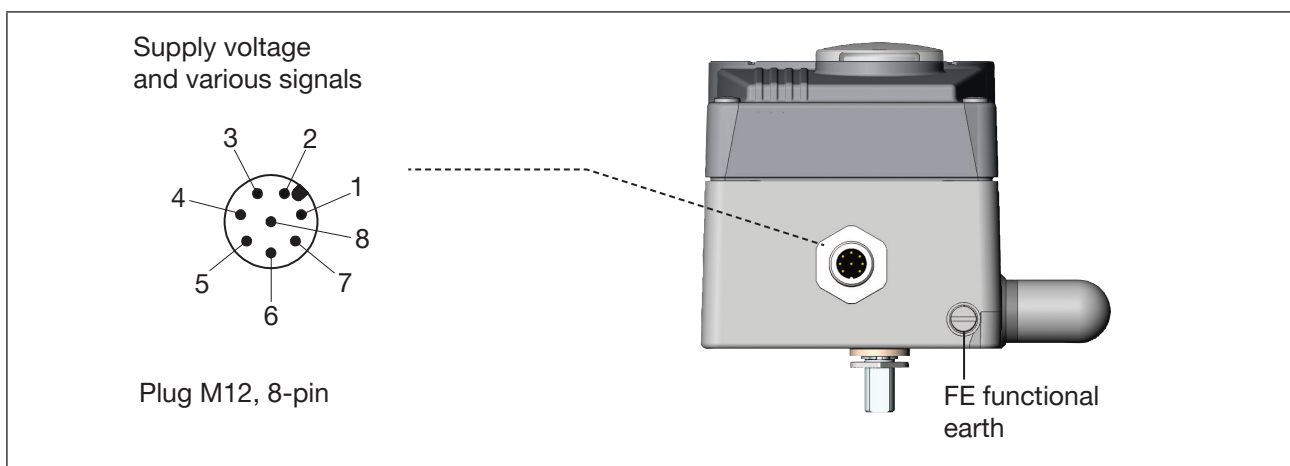



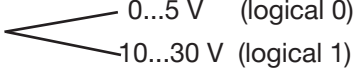

Fig. 33: Designation circular plug-in connector and contacts

13.2.2 Pin assignment for input signals from control centre (e.g. PLC)

Pin	Wire colour*	Assignment	Device end	External circuit/signal level
1	white	Set-point value + (0/4...20 mA)	1  — + (0/4...20 mA)	
2	brown	Set-point value GND	2  — GND	See table 3-conductor or 4-conductor connection type
5	grey	Digital input	5  — +	 0...5 V (logical 0) 10...30 V (logical 1) referring to pin 3 (GND)

* The specified wire colours refer to the connection cable available as an accessory with No. 919061.

Table 27: Pin assignment, input signal from control centre

3-conductor or 4-conductor connection type (configuration with communication software):



4-conductor connection type (factory setting)	3-conductor connection type
<p>The set-point value input is designed as a differential input, i.e. the GND lines of the set-point value input and the supply voltage are not identical.</p> <p>Note: if the GND signals of the set-point value input and the supply voltage are connected, the 3-conductor connection type must be set in the software.</p>	<p>The set-point value input is linked to the GND line of the supply voltage, i.e. set-point value input and supply voltage share a GND line.</p>
 <p>Diagram showing a differential input stage with two input lines (1 and 2) and two supply lines (3 and 4). Line 1 is labeled '0/4...20 mA' and line 2 is 'GND'. Line 3 is 'GND' and line 4 is '+24 V DC'. A resistor is connected between lines 1 and 2.</p>	 <p>Diagram showing a single input line (1) and two supply lines (3 and 4). Line 1 is labeled '0/4...20 mA' and line 3 is 'GND'. Line 4 is '+24 V DC'. A resistor is connected between lines 1 and 3.</p>

Table 28: Connection type

13.2.3 Pin assignment for the output signals to the control centre (PLC, for example), only for the analogue output variant

Pin	Wire colour*	Assignment	Device end	External circuit/signal level
8	red	Analogue feedback +	8  — + (0/4...20 mA)	
7	blue	Analogue feedback GND	7  — GND (identical to GND operating voltage)	

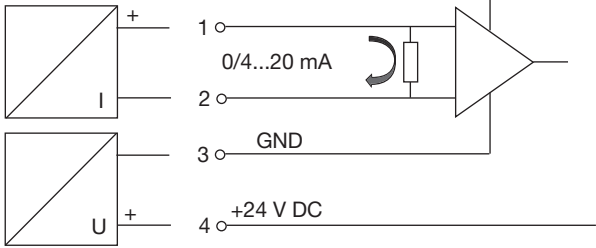
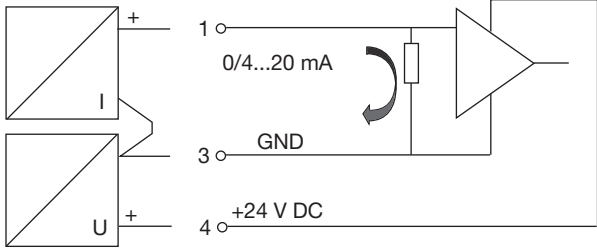
* The specified wire colours refer to the connection cable available as an accessory with No. 919061.

Table 29: Pin assignment, output signal to control centre

13.2.4 Pin assignment for operating voltage

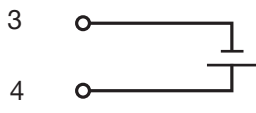
Pin	Wire colour*	Assignment	External circuit/signal level
3	green	GND	 24 V DC $\pm 25\%$ max. residual ripple 10%
4	yellow	+24 V	

* The specified wire colours refer to the connection cable available as an accessory with ID No. 919061.

Table 30: Pin assignment, operating voltage

13.3 Electrical installation with cable gland

13.3.1 Designation of screw-type terminals

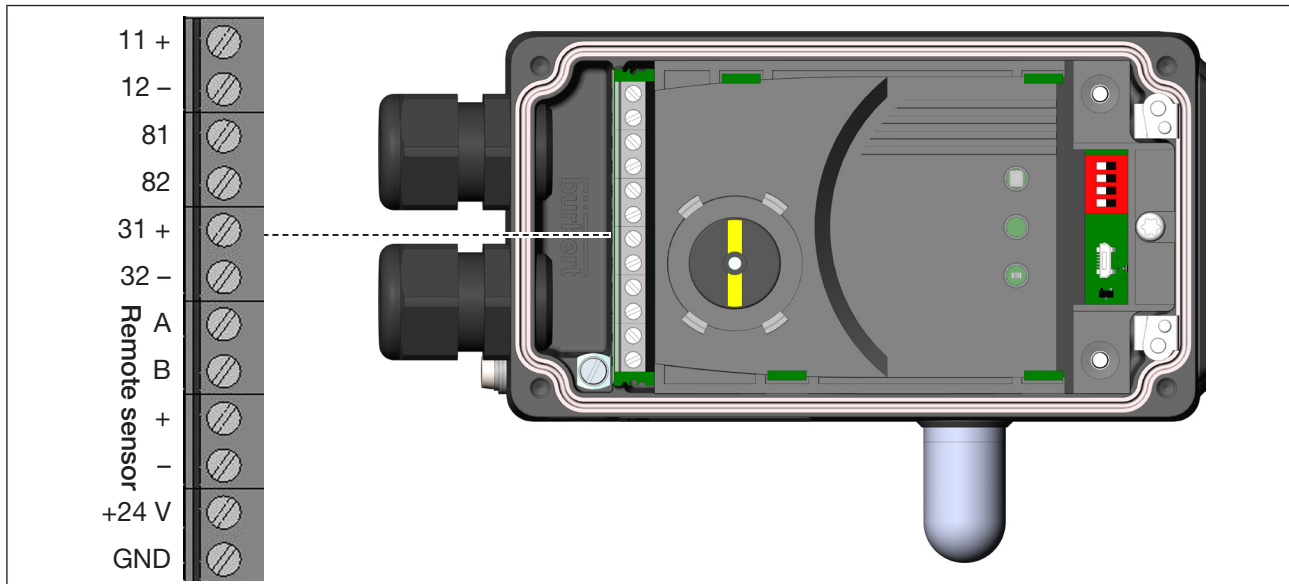

Fig. 34: Designation of screw-type terminals

13.3.2 Connection of terminals

- Unscrew the four screws on the housing cover and remove the cover.
The screw-type terminals are now accessible.
- Connect terminals according to the assignment.

13.3.3 Terminal assignment for input signals from control centre (e.g. PLC)

Terminal	Assignment	Device end	External circuit/signal level
11 +	Set-point value +	11 ○ ——— + (0/4...20 mA)	
12 -	Set-point value GND	12 ○ ——— GND See table 3-conductor or 4-conductor connection type	
81 +	Digital input +	81 + ○ ——— +	0...5 V (logical 0) 10...30 V (logical 1)
82 -	Digital input -	82 - ○ ——— GND (identical to GND operating voltage)	

Table 31: Terminal layout, input signal from control centre

3-conductor or 4-conductor connection type (configuration via communication software):

4-conductor connection type (factory setting)	3-conductor connection type
<p>The set-point value input is designed as a differential input, i.e. the GND lines of the set-point value input and the supply voltage are not identical.</p> <p>Note: if the GND signals of the set-point value input and the supply voltage are connected, the 3-conductor connection type must be set in the software.</p>	<p>The set-point value input is linked to the GND line of the supply voltage, i.e. set-point value input and supply voltage share a GND line.</p>

Table 32: Connection type

13.3.4 Terminal assignment for the output signals to the control centre (PLC, for example), only for analogue output variant

Terminal	Assignment	Device end	External circuit/signal level
31 +	Analogue feedback +	31 + ○ ——— + (0/4...20 mA)	
32 -	Analogue feedback GND	32 - ○ ——— GND (identical to GND operating voltage)	

Table 33: Terminal layout, output signal to control centre

13.3.5 Terminal layout for operating voltage

Terminal	Assignment	External circuit/signal level
+24 V	Operating voltage +	 24 V DC $\pm 25\%$ max. residual ripple 10%
GND	Operating voltage GND	

Table 34: Terminal layout operating voltage

13.3.6 Terminal assignment for external position sensor (only for remote variant)

Terminal	Assignment	Device end	External circuit/signal level
S +	Sensor supply +	S +	 Remote sensor Type 8798 ²³⁾
S -	Sensor supply -	S -	
A	Serial interface, A-line	A	
B	Serial interface; B-line	B	

23) For assignment of wire colour see "Table 36".

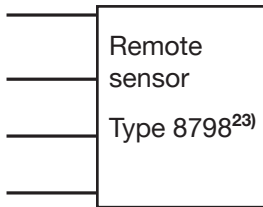
Table 35: Terminal assignment, external position sensor

Positioner terminal	Wire colour Remote sensor with cable type 1	Wire colour Remote sensor with cable type 2
S +	brown	brown
S -	white	black
A	green	red
B	yellow	orange

Table 36: Assignment of wire colour on the remote sensor

14 ELECTRICAL INSTALLATION, IO-LINK

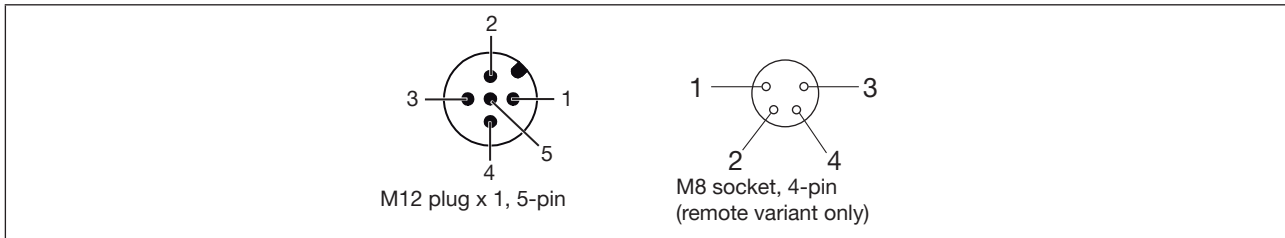

Fig. 35: Pin assignment

Pin assignment port class A

Pin	Designation	Assignment	
1	L +	24 V DC	System supply
2	I/Q	NC	Not used
3	L -	0 V (GND)	System supply
4	C/Q	IO-Link	Communication
5	NC	NC	Not used

Table 37: Pin assignment port class A

Pin assignment port class B

Pin	Designation	Assignment	
1	L +	24 V DC	System supply
2	P24	24 V DC	Actuator supply
3	L -	0 V (GND)	System supply
4	C/Q	IO-Link	Communication
5	N24	0 V (GND)	Actuator supply

Table 38: Pin assignment port class B

14.1 Connection assignment for external position sensor (only for remote variant)

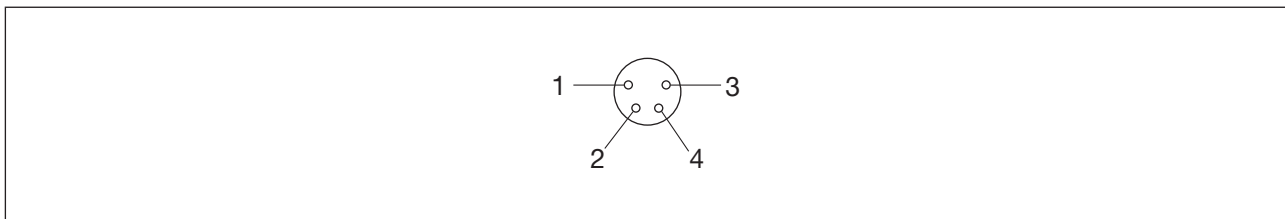

Fig. 36: Pin assignment socket, 4-pin

Pin	Assignment	Device end	External circuit/signal level
1	Sensor supply +	S +	+
2	Sensor supply -	S -	-
3	Serial interface, A-line	A	A-line
4	Serial interface; B-line	B	B-line

Remote sensor
Type 8798²⁴⁾

24) For assignment of wire colour see "Table 40".

Table 39: Pin assignment, external position sensor

Positioner pin	Wire colour Remote sensor with cable type 1	Wire colour Remote sensor with cable type 2
1	brown	brown
2	white	black
3	green	red
4	yellow	orange

Table 40: Assignment of wire colour on the remote sensor

15 ELECTRICAL INSTALLATION, BÜS

	Pin	Wire colour	Assignment
	1	CAN label/shielding	CAN label/shielding
	2	red	24 V DC ±25% max. residual ripple 10%
	3	black	GND/CAN_GND
	4	white	CAN_H
	5	blue	CAN_L

Table 41: Pin assignment



For electrical installation with bÜS network note the following:

Use a 5-pin circular plug and a shielded 5-wire cable.

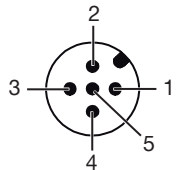
The shielding is capacitively connected to the functional earth through the device.

15.1 Connection assignment for external position sensor (only for remote variant)

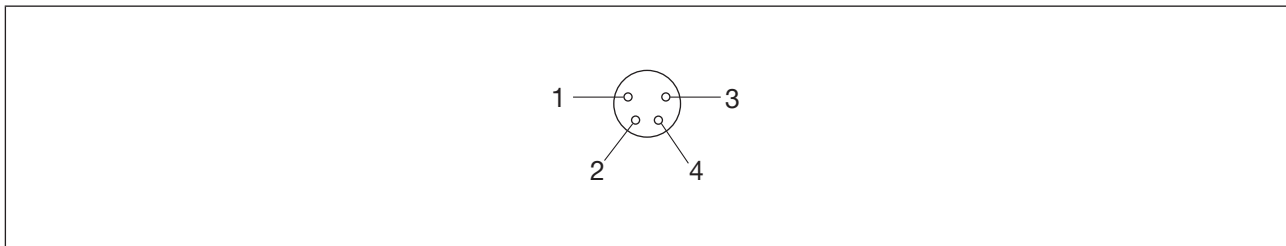









Fig. 37: Pin assignment socket, 4-pin

Pin	Assignment	Device end	External circuit/signal level
1	Sensor supply +	S + 	+ 
2	Sensor supply -	S - 	- 
3	Serial interface, A-line	A 	A-line 
4	Serial interface; B-line	B 	B-line 

Remote sensor
Type 8798²⁵⁾

25) For assignment of wire colour see "Table 43".

Table 42: Pin assignment; external position sensor

Positioner pin	Wire colour Remote sensor with cable type 1	Wire colour Remote sensor with cable type 2
1	brown	brown
2	white	black
3	green	red
4	yellow	orange

Table 43: Assignment of wire colour on the remote sensor

16 START-UP

16.1 Safety instructions



WARNING!

Risk of injury due to improper operation.

Improper operation may result in injuries as well as damage to the device and the area around it.

- ▶ Before start-up, ensure that the operating personnel are aware of and have completely understood the contents of the operating instructions.
- ▶ The safety instructions and the intended use must be observed.
- ▶ Only adequately trained personnel may start up the system/device.

16.2 Defining base settings

The base settings of the positioner are configured in the factory.



To adapt the positioner to the local conditions, the *X.TUNE* function must be executed after installation.

16.2.1 Execute the *X.TUNE* automatic adjustment



WARNING!

Risk from changing the valve position when executing the *X.TUNE* function.

If *X.TUNE* is operated under operating pressure there is an acute risk of injury.

- ▶ *Never execute X.TUNE* when a process is running.
- ▶ Secure the system against unintentional activation.

NOTE!

Avoid incorrect controller adjustment from incorrect supply pressure or activated operating medium pressure.

- ▶ **Always** execute *X.TUNE* in case of supply pressure (pneumatic auxiliary power) present in later operation.
- Ideally, execute the *X.TUNE* function **without** operating medium pressure to prevent interference as a result of flow forces.

→ Unscrew the four screws on the housing cover and remove the housing cover.



To execute *X.TUNE* the positioner must be in **AUTOMATIC** operating state (DIP switch 4 = OFF).

→ Start *X.TUNE* by pressing key 1 for 5 s²⁶⁾.

LED 2 flashes at 5 Hz. The device is in NAMUR state functional inspection, LED1 lights orange.

If *X.TUNE* has been successfully complete, the NAMUR state is reset. The changes are automatically adopted in the memory (EEPROM).

If LED1 lights red after *X.TUNE*:

→ Execute *X.TUNE* again.

→ Perform device restart if necessary.

16.3 Set device with Bürkert Communicator

All settings can be made on the device with Bürkert Communicator.



You can find the settings in Bürkert Communicator in the operating instructions.

16.3.1 Connecting the IO-Link device to the Bürkert Communicator

Necessary components:

- Communication software: Bürkert Communicator for PC
- USB büS interface set (see accessories)
- büS adapter for communication interface (see accessories)
- A büS cable extension if necessary (see accessories)

→ To connect the IO-Link device to Bürkert Communicator, unscrew the housing cover.

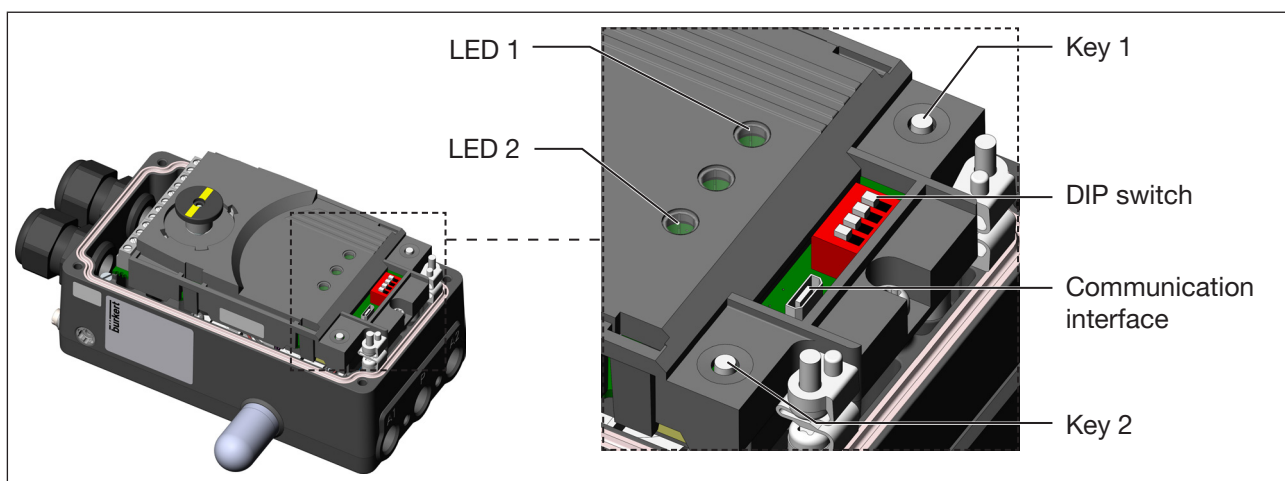

Fig. 38: Description of operating elements

26) *X.TUNE* can also be started via communication software.

- Insert the Micro USB plug into the communication interface.
- Make the connection to the PC with the USB büS interface set.
- Start the Bürkert Communicator.
- Configure settings.

16.3.2 Connecting the büS device to the Bürkert Communicator

Necessary components:

- Communication software: Bürkert Communicator for PC
- USB büS interface set (see accessories)

- Make the connection to the PC with the USB büS interface set.
- Start the Bürkert Communicator.
- Configure settings.

17 IO-LINK

17.1 Information, IO-Link

IO-Link is an internationally standardised IO technology (IEC 61131-9) for communicating with sensors and actuators.

IO-Link is a point-to-point communication system with 3-wire connection technology for sensors and actuators and unshielded standard sensor lines.

To ensure unambiguous communication, IO-Link devices should not be configured simultaneously using the global controller (PLC) via the IO-Link master and using the Bürkert Communicator (via the communication interface).

17.2 Technical data, IO-Link

IO-Link specification	V1.1.2
Supply	via IO-Link (M12 x 1, 5 pin, A-coded)
Port class	A or B
SIO mode	No
IODD file	See Internet
VendorID	0x0078, 120
DeviceID	See IODD file
ProductID	8791
Transmission speed	COM3 (230.4 kbit/s)
PD input bits	80
PD output bits	40
M-sequence cap.	0x0D
Min. cycle time	5 ms
Data storage	Yes
Max. line length	20 m

17.3 Configuring the fieldbus

The necessary start-up files and the description of the process data and acyclic parameters are available online.



Download at:

www.burkert.com / Type 8791 / Software

18 BÜS

18.1 Information, büS

büS is a system bus developed by Bürkert with a communication protocol based on CANopen.

18.2 Configuring the fieldbus

The necessary start-up files and the description of the objects are available online.



Download at:

www.burkert.com / Type 8791 / Software

19 MAINTENANCE

If the positioner Type 8791 is operated in accordance with the steps of these instructions, no maintenance is required.

20 ACCESSORIES



CAUTION!

Risk of injury and/or damage due to incorrect parts.

Incorrect accessories and unsuitable spare parts may cause injuries and damage the device and the area around it

- ▶ Use only original accessories and original spare parts from Bürkert.



You can find the order numbers of the attachment kits for linear or rotary actuators and the matching cable plug of the multi-pin variant of the positioner in the Type 8791 data sheet.

Designation	Order no.
Connection cable M12 x1, 8-pin	919061
Bürkert Communicator communication software	Info at www.buerkert.de
USB bÜS interface set:	
USB bÜS interface set 2 (bÜS stick + 0.7 m cable with M12 plug)	772551
bÜS adapter for communication interface (M12 to bÜS service interface micro-USB)	773254
bÜS cable extension (M12 plug to M12 socket), length 1 m	772404
bÜS cable extension (M12 plug to M12 socket), length 3 m	772405
bÜS cable extension (M12 plug to M12 socket), length 5 m	772406
bÜS cable extension (M12 plug to M12 socket), length 10 m	772407

Table 44: Accessories

20.1 Communication software

The Communicator PC operating program has been designed for communication with devices from the Bürkert positioner family.

Please contact the Bürkert Sales Center for compatibility questions.



A detailed description of the installation and operation of the software can be found in the associated operating instructions.

Download the software from: country.buerkert.com.

21 PACKAGING, TRANSPORT, DISPOSAL

ATTENTION

Damage in transit due to inadequately protected devices.

- ▶ Protect the device against moisture and dirt in shock-resistant packaging during transportation.
- ▶ Observe permitted storage temperature.

ATTENTION

Incorrect storage may damage the device.

- ▶ Store the device in a dry and dust-free location.
- ▶ Storage temperature: -20...+65 °C

Environmentally friendly disposal



- ▶ Follow national regulations regarding disposal and the environment.
- ▶ Collect electrical and electronic devices separately and dispose of them as special waste.

Further information country.burkert.com.

