

# SERVOTOUGH Laser 3 Plus - DeNOx Ammonia

THE SERVOTOUGH LASER 3 PLUS DeNOx AMMONIA, NEXT-GENERATION TUNABLE DIODE LASER (TDL) SINGLE PATH SPECTROMETER, COMBINES UNIQUE FEATURES, LEADING PERFORMANCE AND REDUCED COST-OF OWNERSHIP IN A REVOLUTIONARY COMPACT DESIGN.



## SERVOTOUGH Laser 3 Plus - DeNOx Ammonia

The SERVOTOUGH Laser 3 Plus is a revolution in TDL Absorption Spectroscopy analysis: a highly compact gas monitor for in-situ cross stack applications, which delivers exceptional performance benefits in a compact design.

Servomex's pioneering approach to design has produced an analyzer that occupies a footprint up to 1/10th the size of competitor products and includes an integrated display and key pad. This provides instant benefits in terms of installation ease and flexibility.

The SERVOTOUGH Laser 3 Plus delivers exceptional TDL performance with a fast response to Ammonia in a wide range of applications. Utilizing the latest Wavelength Modulated Spectroscopy (WMS) measurement techniques with advanced Servomex signal processing, the Laser 3 Plus provides stable and repeatable results with minimal installation and maintenance costs.

### FLEXIBLE

- Compact design
- Performs in high particulate environments
- Path lengths from 0.7m to 10m
- Minimal cross interference
- Diverse mounting: ideal for ducts, stacks and reactor installations

### EASY TO USE

- Simple to install and operate
- Robust and reliable
- Space saving
- Digital communications Modbus over Ethernet
- User friendly interface and rapid disconnect for easy calibration

### LOW COST OF OWNERSHIP

- Intuitive alignment for easy installation and maintenance
- Non-depleting TDL technology
- No moving parts, no consumables
- No sample conditioning system - reduced maintenance costs
- No hazardous area purge required

### UNRIVALLED PERFORMANCE

- Process temperatures up to 600°C \*
- Low detection limit
- Negligible zero drift
- Calibration 6-12 month

### BENCHMARK COMPLIANCE

- ATEX, IECEx hazardous area approvals
- North American hazardous area Class 1 Div 2
- IP66
- SIL 2
- CE approved

\* Application and measurement dependent

**WITH LINE LOCK TECHNOLOGY - SAFE, SECURE, RELIABLE**

Learn more about the SERVOTOUGH Laser 3 Plus  
VISIT [SERVOMEX.COM](http://SERVOMEX.COM)



[SERVOMEX.COM](http://SERVOMEX.COM)

# PRODUCT OVERVIEW: Laser 3 Plus - DeNOx Ammonia

## A REVOLUTIONARY APPROACH TO TDL GAS ANALYSIS

By combining the latest advances in hardware with leading-edge software processing, the SERVOTOUGH Laser 3 Plus is a revolutionary step forward for TDL gas analysis. Servomex has approached TDL analysis afresh, creating an analyzer a fraction of the size without compromising performance. The result is TDL analysis that is easier and faster to install - saving valuable space while enabling much greater installation flexibility.

## LOW MAINTENANCE, LOW COST-OF-OWNERSHIP

The next-generation ethos of the Laser 3 Plus works hard to reduce costs at all stages. In addition to the immediate advantages of TDL technology - a non-depleting measurement which requires no sample conditioning system - the Laser 3 Plus compact design greatly reduces installation time, with small, light intuitive alignment for easy installation and maintenance. Full ethernet communications for commissioning, diagnostics and trouble shooting.

## HIGH PERFORMANCE MONITORING

The hardware advances of the Laser 3 Plus are matched by advanced Wave Length Signal Modulated Spectroscopy processing software which eliminates drift over extended operational periods by automatically tracking on a sealed reference cuvette absorption line - Line Lock Technology. This robust tracking mechanism ensures a highly reliable and accurate operation over long periods, with calibration frequencies extended beyond twelve months for many applications.

The result is a sturdy, general purpose and hazardous area optimized design which ensures Laser 3 Plus can handle the most challenging of locations; including particulate-rich environments.

## LINE LOCK TECHNOLOGY - SAFE, SECURE, RELIABLE.

### KEY APPLICATIONS

- Process Heaters
- Incinerators
- Thermal Crackers
- Thermal Oxidizers
- Power Stations
- Furnaces



# PRODUCT OVERVIEW: Laser 3 Plus - DeNOX Ammonia

MEASUREMENT	DETECTION LIMIT * ‡	MIN. RANGE ‡	MAX. RANGE ‡	MAX. PRESSURE BAR ABSOLUTE ‡	MAX. TEMPERATURE/°C ‡	MAX. PATH LENGTH ‡
NH <sub>3</sub>	0.2ppm	0-15ppm	0-150ppm	1.2	600	10m
<b>NOTES</b>	* Detection limits are specified as the 95% confidence interval for 1m optical path and gas temperature/pressure = to 25°C/1 bar abs. ‡ Dependent on temperature, path length and dust. Refer to Servomex for application specific performance and limits.					

SPECIFICATION	
Technology	Single Line Tunable Diode Laser Spectroscopy
Optical path length *	0.7-10m
Measurement update rate	5 readings per second
T <sub>90</sub> response time **	Minimum 1 second †
Zero drift	Negligible, <2% FSR between calibrations
Span drift	<4% FSR between calibrations
Linearity	1% FSR
Calibration	Recommended every 6-12 months
Maintenance	Recommended every 12 months
Outputs and alarms	4-20 mA output: Isolated current loops, 500 Ω maximum 4-20 mA input: Maximum current 22mA input impedance 50 Ω Status Relays: 1A at 30V Vdc/ac
Digital communications	Modbus TCP/IP Ethernet (10 or 100 base)
Power supply	24V dc
Measurement availability	Optimal measurement availability via sealed reference cuvette and Servomex's unique line lock technology principle as standard.
<b>NOTES</b>	* Application dependent, on temperature, pathlength and dust. Refer to Servomex for further details. ** Quoted specifications at T <sub>10</sub> - T <sub>90</sub> <30 seconds.

FEATURES	
Pathlength specific optics	Optics are specified to ensure optimal measurement performance
Outputs and alarms options	Standard: 1 x 4-20 mA output, 1 x Status Relay Additional option Card: 1 x 4-20mA output, 2 x Status Relays, 2 x 4-20mA inputs
Flange sizes *	DN25, DN50, ANSI 1", 2", 3" and 4"
Sample wetted seals †	Viton 70 (standard) or Chemraz 505 (solvent resist)
In-line span cell *	Validation of reading
Accessories	Accessories such as alignment tools, calibration cell kits, purge panels and insertion tubes, isolation flanges and thermal spacers are available for specific applications – contact your local servomex business center
<b>NOTES</b>	* Application dependent † Or equivalent



# PRODUCT DATA: Laser 3 Plus - DeNOx Ammonia

## DEVICE SPECIFICATION

### Size:

- TRANSMITTER:  
131mm width (5<sup>1</sup>/<sub>8</sub>"")  
164mm high (6<sup>1</sup>/<sub>2</sub>"")  
302.4mm deep (11<sup>9</sup>/<sub>10</sub>"")
- RECEIVER:  
110mm width (4<sup>5</sup>/<sub>16</sub>"")  
146mm high (5<sup>3</sup>/<sub>4</sub>"")  
247.6mm deep (9<sup>3</sup>/<sub>4</sub>"")

### Weight:

- TRANSMITTER: <3.0 kg (6.6 lbs)
- RECEIVER: <2.0 kg (4.4 lbs)

### Operating temperature:

- -20°C to +65°C (standard)

### Certifications:

- ATEX Cat 3 (Gases)
- ATEX Cat 21 (Dust)
- IECEx Zone 2 and Zone 21
- North American Class 1 Division 2 and Zone 2 (Gas and Dust)
- Safe Area / General Purpose
- CE marked in compliance with ATEX, EMC, LVD and all other applicable directives

### Protection Class:

- IP66
- NEMA 4X

*These analyzers are not intended for any form of use on humans and are not medical devices as described in the Medical Devices Directive 93/42EEC.*

## DEVICE SCHEMATIC

### Transmitter

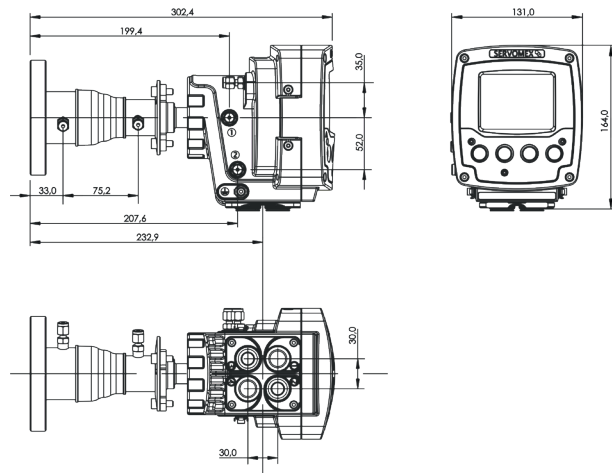

### Receiver

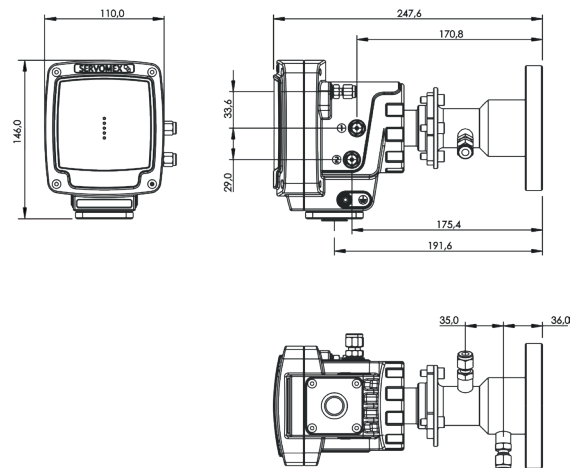

**Please note:** While every effort has been made to ensure accuracy, no responsibility can be accepted for errors or omissions. Data may change, as well as legislation, and you are strongly advised to obtain copies of the most recently issued regulations, standards and guidelines. This document is not intended to form the basis of a contract.

AMERICAS BUSINESS CENTER  
Tel: +1 281 295 5800  
Email: americas\_sales@servomex.com

ASIA PACIFIC BUSINESS CENTRE  
Tel: +86 (0)21 6489 7570  
Email: asia\_sales@servomex.com

EUROPEAN BUSINESS CENTRE  
Tel: +44 (0) 1892 603330  
Email: europe\_sales@servomex.com

INDIA BUSINESS CENTRE  
Tel: +91 22 3934 2700  
Email: MEI\_sales@servomex.com

MIDDLE EAST BUSINESS CENTRE  
Tel: +971 6552 8073  
Email: MEI\_sales@servomex.com