

# SFU

## Gas Sampling Unit

with Weatherproof Enclosure

**SICK**  
Sensor Intelligence.

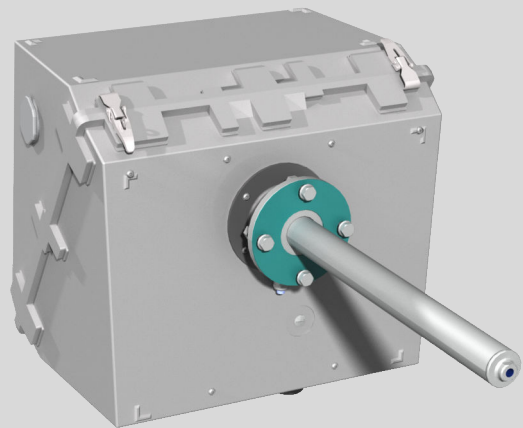

---

### **Described product**

SFU (gas sampling unit) with higher protection class

These Operating Instructions refer to the gas sampling unit of the SFU-BF NI GL in the weatherproof enclosure.

### **Manufacturer**

SICK AG  
Erwin-Sick-Str. 1  
79183 Waldkirch  
Germany

### **Legal information**

This work is protected by copyright. Any rights derived from the copyright shall be reserved for SICK AG. Reproduction of this document or parts of this document is only permissible within the limits of the legal determination of Copyright Law. Any modification, abridgment or translation of this document is prohibited without the express written permission of SICK AG.

The trademarks stated in this document are the property of their respective owner.

© SICK AG. All rights reserved.

### **Original document**

This document is an original document of SICK AG.



## Contents

<b>1</b>	<b>About this document.....</b>	<b>5</b>
1.1	Function of this document.....	5
1.2	Target group.....	5
1.3	Symbols and document conventions.....	5
1.3.1	Warning symbols.....	5
1.3.2	Warning levels / signal words.....	6
1.3.3	Information symbols.....	6
<b>2</b>	<b>Safety information.....</b>	<b>7</b>
2.1	Basic safety information.....	7
2.2	Warnings on the device.....	7
2.3	Intended use.....	8
2.4	Qualification of the operator.....	8
<b>3</b>	<b>Product description.....</b>	<b>9</b>
3.1	Product identification.....	9
3.2	Product description.....	10
3.3	Design.....	11
3.3.1	Gas sampling tube.....	11
<b>4</b>	<b>Installation and start-up.....</b>	<b>12</b>
4.1	Important information.....	12
4.2	Weatherproof enclosure.....	13
4.3	Preparing the connection bundle.....	14
4.4	Mounting.....	15
4.4.1	Installing the welding neck flange.....	15
4.4.2	Connection of sample gas line.....	17
4.4.3	Connection of the pneumatic lines.....	18
4.5	Electrical installation.....	19
4.6	Installing the gas sampling tube on the gas sampling unit.....	20
4.7	Installing the SFU on the welding neck flange.....	20
<b>5</b>	<b>Maintenance.....</b>	<b>22</b>
5.1	Important Information.....	22
5.2	Maintenance plan.....	22
5.3	Spare parts.....	23
5.4	Replacing the sintered metal filter element.....	23
5.5	Replacing the glass fiber filter element.....	26
5.6	Retrofitting the filter element.....	29
5.7	Checking for correct operation.....	32
<b>6</b>	<b>Troubleshooting.....</b>	<b>33</b>
6.1	Troubleshooting.....	33
<b>7</b>	<b>Disposal.....</b>	<b>34</b>

<b>8</b>	<b>Technical data.....</b>	<b>35</b>
8.1	Compliances and Standards.....	35
8.2	Dimensions.....	35
8.3	Operating data.....	35

# 1 About this document

## 1.1 Function of this document

These Operating Instructions describe:

- Device components
- Installation
- Operation
- Maintenance work required for reliable operation

## 1.2 Target group

This document is addressed to technicians (persons with technical understanding) installing, operating and maintaining the measuring system.

### Responsibility of the operator



- Use the device only as described in these Operating Instructions. The manufacturer assumes no responsibility for any other use.
- Maintenance work should be performed as prescribed in this Manual.
- Do not remove, add or change any components in or on the device unless such changes are officially allowed and specified by the manufacturer.
  - Otherwise the manufacturer's warranty becomes void.
  - Otherwise the device can become dangerous.
- Observe special local conditions.
  - Follow all local laws, regulations, and company policies applicable at the installation location.
- Retain documents. These Operating Instructions:
  - Must be kept available for reference.
  - Must be passed on to new owners.





### Requirements on the maintenance personnel

- The technician must be familiar with the exhaust gas technology of the operator's plant (overpressure, toxic and hot flue gases) and be able to avoid hazards when working on gas ducts.
- The technician must be familiar with handling compressed gas cylinders (span gases).
- The technician must be able to avoid hazards caused by noxious span gases.
- The technician must be familiar with gas lines (PTFE lines) and their screw fittings (be able to ensure gas-tight connections).
- Only electricians are permitted to work on the electrical system or electrical sub-assemblies.

## 1.3 Symbols and document conventions

### 1.3.1 Warning symbols

Symbol	Significance
	Hazard (general)
	Hazard by voltage

Symbol	Significance
	Hazard by acidic substances
	Hazards by noxious substances
	Hazard by high temperature
	Hazard for the environment/nature/organic life

1.3.2 Warning levels / signal words

**DANGER**

Risk or hazardous situation which will result in severe personal injury or death.

**WARNING**

Risk or hazardous situation which could result in severe personal injury or death.

**CAUTION**

Hazard or unsafe practice which could result in less severe or minor injuries.



**Notice**

Hazard which could result in property damage.

**Note**

Hints.

1.3.3 Information symbols

Symbol	Significance
	Important technical information for this product
	Important information on electric or electronic functions

## 2 Safety information

### 2.1 Basic safety information

- 
- WARNING**  
 Health risk through dangerous sample gas  
 If dangerous sample gas is applied to the SFU:
- ▶ The operator is responsible for safe handling of sample gas.
- 

- WARNING**  
 Risk of explosion in potentially explosive atmospheres
- ▶ Do not operate the SFU in potentially explosive atmospheres.
- 

- WARNING**  
 Hazard through explosive or ignitable gases
- ▶ Do not use the SFU for measuring explosive or combustible gases.
- 

### 2.2 Warnings on the device

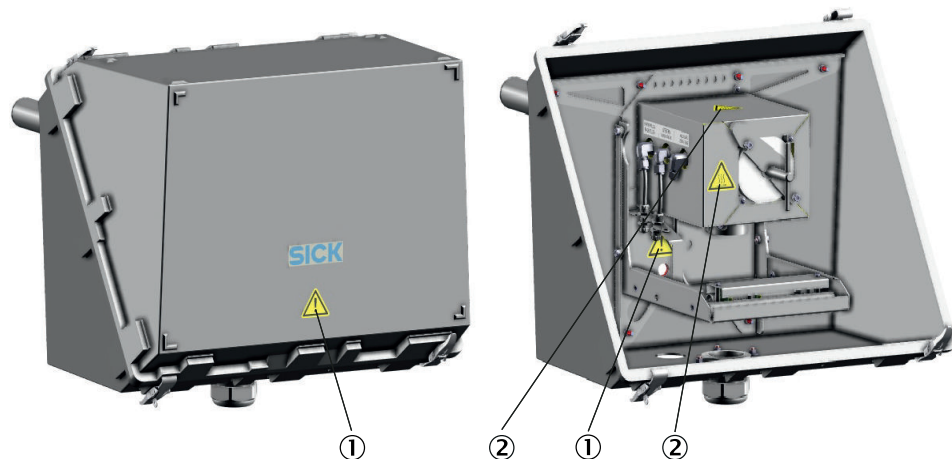

Figure 1: Location of the warning signs on the device

- ① Warning sign "Caution!"
- ② Warning sign "Hot surface!"

- 
- DANGER**  
 Hazard by voltage
- ▶ Only authorized electricians may perform work on electrical components.
  - ▶ Do not touch live components.
  - ▶ Disconnect the device from the power supply before working on electrical components (e.g. by switching off the measuring system).
-



### **WARNING**

Risk of burns on hot surfaces

- ▶ Avoid contact with hot surfaces or wear protective clothing (e.g. protective gloves).
  - ▶ Lay hot parts on fireproof supports only.
- 

### **2.3 Intended use**

The gas sampling unit is used for extracting a partial stream of a gas mixture (usually flue gas) from a line, stack or similar and for retaining particles that are contained in the gas stream.

### **2.4 Qualification of the operator**

The SFU may only be maintained by persons properly instructed on the tasks assigned, possible risks and protective measures.



## 3 Product description

### 3.1 Product identification

Product name	SFU-BF NI GL The exact type designation can be found on the type plate.
Accessories:	<ul style="list-style-type: none"> <li>• 0.5 m unheated maritime gas sampling tube</li> <li>• 0.8 m unheated maritime gas sampling tube</li> <li>• 0.5 m heated gas sampling tube</li> <li>• 0.8 m heated gas sampling tube</li> <li>• 1.0 m heated gas sampling tube</li> <li>• 1.5 m heated gas sampling tube</li> <li>• 2.0 m heated gas sampling tube</li> <li>• IP54 enclosure</li> </ul> <p>Can already be ordered pre-assembled in combination with the maritime gas sampling unit SFU-BF NI GL</p>
Name of the pre-assembled set: Consisting of:	SFU-BF NI GL in IP54 enclosure (PN 2098126) <ul style="list-style-type: none"> <li>• SFU-BF NI GL</li> <li>• IP54 enclosure for SFU</li> </ul>
Manufacturer	SICK AG Erwin-Sick-Str. 1 · D-79183 Waldkirch · Germany
Type plate	The type plate is located on the underside of the gas sampling unit.



#### NOTICE

It is possible that your SFU has a different configuration to that described in this Manual.

- Refer to the System Documentation delivered with your SFU for the individual configuration of your system.

#### 3.2 Product description

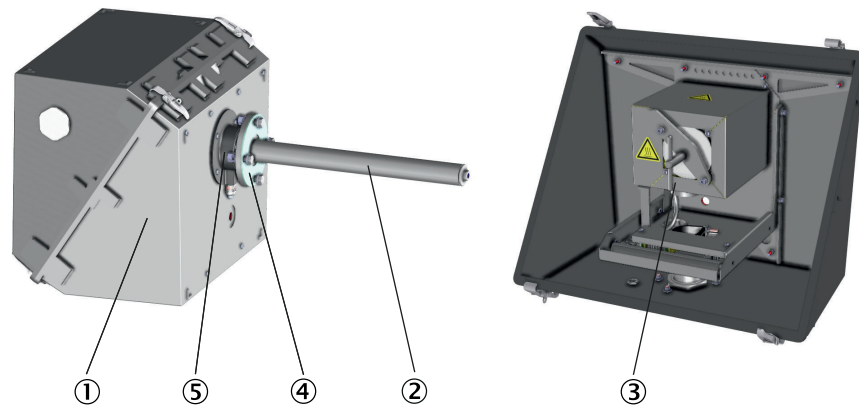

Figure 2: Example configuration of a set consisting of weatherproof enclosure and SFU

- ① Weatherproof enclosure
- ② Gas sampling tube
- ③ SFU filter housing
- ④ Flange
- ⑤ Silicone press ring seal (gas sampling tube seal)

The gas sampling unit consists of filter housing, gas sampling tube, weatherproof enclosure and optional pre-filter.

##### Application area

The gas sampling unit SFU is used for flue gas extraction and filtering for analysis in a measuring system.

The flue gas is taken via a gas sampling tube and fed to a measuring system after filtration.

The gas sampling tube is optionally available in various lengths.

As an option, the gas sampling tube contains a pre-filter at the probe tip.

For maritime applications, unheated gas sampling tubes without pre-filters are used.

##### Measuring system

The gas sampling unit is operated on a SICK measuring system. Thus, only this operating mode is described in this Manual.

Applications with customer-owned peripheral devices are not planned.

### 3.3 Design

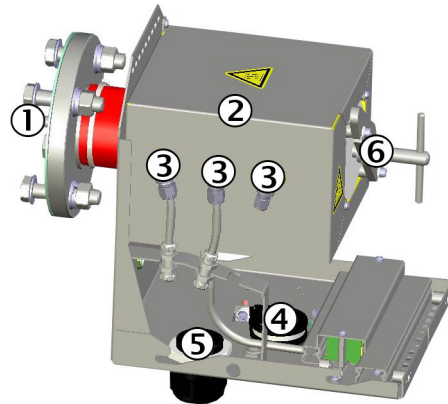

Figure 3: SFU-BF NI GL

- ① Gas sampling tube
- ② Filter housing
- ③ 3 pneumatic lines (backflush, activation of main valve, zero gas)
- ④ Output sample gas line
- ⑤ Input connection bundle (electrical and pneumatic lines)
- ⑥ Filter element with rotary handle

The gas sampling unit consists of the following subassemblies:

- Gas sampling tube:
  - Heated gas sampling tube:
  - Unheated maritime gas sampling tube
  - Optional: Pre-filter at the tip of the gas sampling tube
- SFU in IP54 enclosure:
  - Heated filter housing with filter element
  - Weatherproof enclosure

The electrically heated filter housing is made of coated aluminum. The filter housing is insulated by an aluminum housing lined with polyimide.

The weatherproof enclosure is made of glass fiber reinforced plastic (GRP).

#### Thermostatic control

The gas sampling unit is thermostatically controlled.

- Heating control with Pt100 sensor and external heating control
- Limit value monitoring in the controller of the measuring system

#### 3.3.1 Gas sampling tube

The length of the gas sampling tube depends on the conditions at the sampling point.

The gas sampling tube is available for maritime applications in an unheated version.

Type and length of the gas sampling tube are described in the supplied system documentation.



#### NOTE

The gas sampling tube is supplied pre-assembled.

## 4 Installation and start-up

### 4.1 Important information



**WARNING**

Risk of injury by a heavy load

The weatherproof enclosure including the sampling system with flange weighs approx. 30 kg.

- ▶ Use proper lifting techniques to lift or move the device.
- ▶ Lift the unit by the enclosure. If necessary, remove the cover in order to grip the device better and reduce the weight.
- ▶ Always work in pairs.



**WARNING**

Health risk through dangerous sample gas

If dangerous sample gas is applied to the SFU: The operator is responsible for safe handling of sample gas.

- ▶ In addition to these Operating Instructions, observe all local laws, technical rules, and company-internal instructions valid at the site where the SFU is installed.
- ▶ Operate the SFU only in rooms with adequate installation OR install suitable gas monitoring equipment.
- ▶ Channel sample gas off safely.



**WARNING**

Hazard through sample gas pressure

The stacks can have underpressure or overpressure.

- ▶ Observe information from the plant operator.



**WARNING**

Risk of burns on hot surfaces

Filter housing, flanges and sample gas line can be hot.

- ▶ Allow the surface of the device parts to cool down to body temperature or wear suitable protective gloves.



**WARNING**

Danger to life by electric voltage

- ▶ Only allow an authorized electrician to work on the electric system.

The assembly of the gas sampling unit contains the following work steps:

Step	Work step	Special features	Side
1	Install the welding neck flange	Has to be performed by the operator beforehand	<a href="#">page 15</a>
2	Connect the sample gas line		<a href="#">page 17</a>
3	Connect the hoses for valves		<a href="#">page 18</a>
4	Connect the electrical connections		<a href="#">page 19</a>
5	Install the gas sampling tube		<a href="#">page 20</a>

Step	Work step	Special features	Side
6	Attach the SFU to the welding neck flange	Observe preheating period	<a href="#">page 20</a>

## 4.2 Weatherproof enclosure

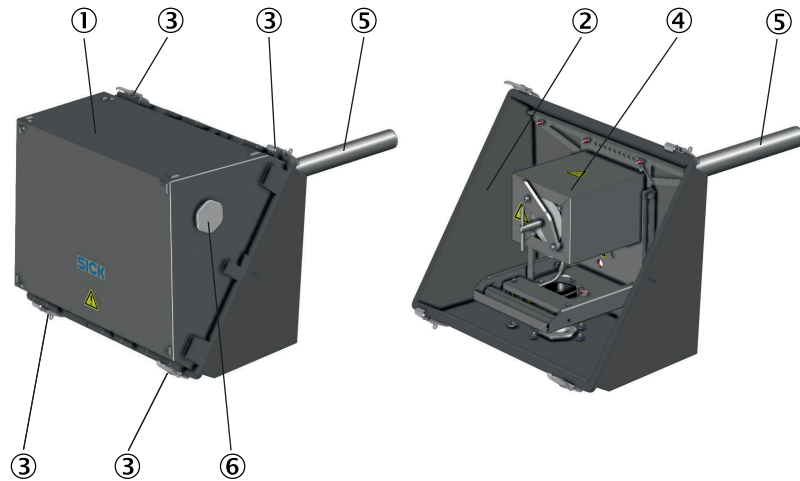

Figure 4: SFU-BF NI GL in weatherproof enclosure (closed left and open right)

- ① Enclosure cover
- ② Enclosure base
- ③ Tension locks
- ④ Filter housing
- ⑤ Gas sampling tube
- ⑥ Ventilation membrane



### DANGER

Hazard by voltage

Live parts are accessible after the weatherproof enclosure has been opened.

- ▶ Disconnect the gas sampling unit from the power supply before opening the enclosure (for example by switching off the measuring system).



### CAUTION

Risk of burns on hot surfaces

You can perform the work while the filter is hot.

- ▶ Wear suitable gloves.

### Removing the enclosure cover

- 1 Unlock the tension locks.
- 2 Pull the enclosure cover away from the gas sampling tube and lift.

### Fitting the enclosure cover

- 1 Fit the enclosure cover in the direction of the gas sampling tube.
- 2 Lock the tension locks.

### 4.3 Preparing the connection bundle



Figure 5: Standard connection bundle

Standard hose bundle cable (system-specific example) with:

- Power supply
- Grounding conductor yellow/green
- Signal lines
- Tube, gray: Zero gas/span gas
- Tube, black: Main valve
- Tube, blue: Backflush

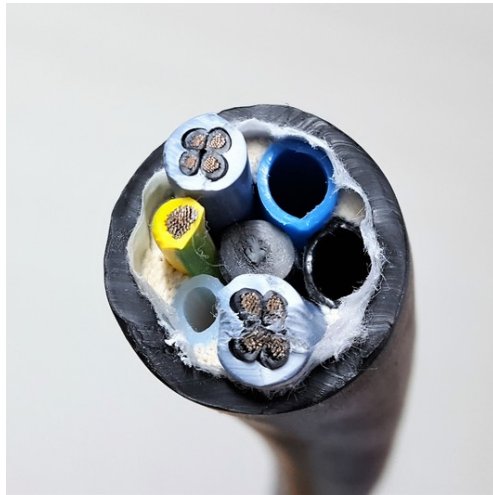

Figure 6: DNV GL approved connection bundle:

DNV GL approved connection bundle:

- Power supply
- Grounding conductor yellow/green
- Signal lines
- Tube, gray: Zero gas/span gas
- Tube, black: Main valve
- Tube, blue: Backflush

Halogen-reduced for use on passenger ships

Additionally improved protection against fire

The connection bundle (option) connects the SFU with the measuring system.

---

### Preparation of the connection bundle

---

**NOTE**

Leave a sufficient length for pulling the gas sampling unit out of the stack (approx. 2 m).

---

- 1 Strip the connection bundle and shorten the hoses and lines to the required length.  
Cut the hoses at right angles. Avoid damaging the lines and hose lines.
- 2 Cut the flexible wires to the required length. Press the crimp lead end sleeves onto the ends of the flexible wires.

## 4.4 Mounting

### 4.4.1 Installing the welding neck flange

---

**WARNING**

Risk of burns by hot flanges.

The flanges can reach high temperatures.

- ▶ Before starting any work on the flanges, allow the flanges to cool down to body temperature or wear appropriate protective gloves.
- 

**DANGER****Health risk through hot or toxic gases/dusts in the measuring duct**

The measuring duct can contain hot or toxic gases or dust deposits which can escape when opening the duct-side flange. Even if the measuring duct is out of operation during the installation, escaping gases can lead to severe damage to health.

- ▶ Always put the measuring duct out of operation for the duration of the installation.
  - ▶ If required, purge the measuring duct with ambient air before starting installation work.
  - ▶ During installation work, always wear protective clothing which is suitable or specified by the operating company.
- 

The operator is responsible for installing the welding neck flange.

The specifications of the flange connection are described in the System Documentation delivered.

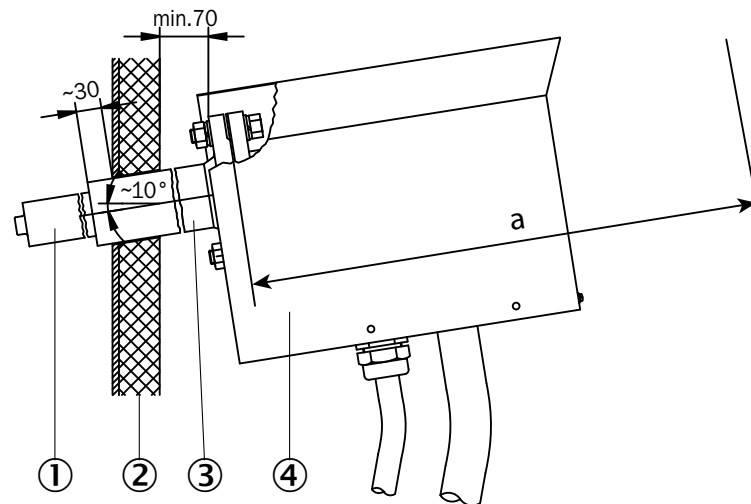

Figure 7: Installation requirements for welding neck flange

- ① Gas sampling tube
- ② Stack wall
- ③ Welding neck flange
- ④ Probe filter

- ▶ Attach the flange with a tilt of approx. 10°.
- ▶ The minimum distance a behind welding neck flange must be min. the length specified in the following table in order to maintain and dismantle the gas sampling unit.

Table 1: Minimum distance behind welding neck flange

Length of gas sampling tube	Minimum distance a
0.5 m	915 mm
0.8 m	1215 mm
1.0 m	1415 mm
1.5 m	1915 mm
2.0 m	2415 mm



4.4.2 Connection of sample gas line

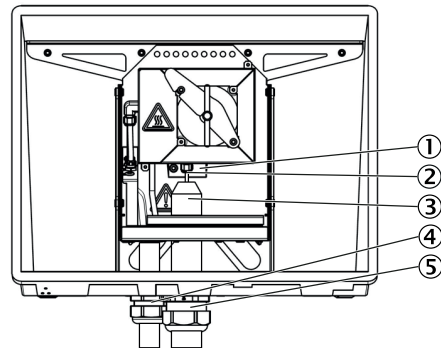

Figure 8: Sample gas connection SFU-BF NI GL in weatherproof enclosure

- ① Insulating shell
- ② Clamping ring screw connection
- ③ Sample gas line
- ④ Cable gland with cap nut, small
- ⑤ Cable gland with cap nut, large



**NOTE**

If you lay the heated sample gas line before installing the gas sampling unit: Observe the installation of the sample gas line:

- ▶ Start laying at the measuring system:
  - The end **with** electrical connection is connected to the measuring system.
  - The end **without** electrical connection is connected to the gas sampling unit. Roll up excess length at the gas sampling unit. Leave enough length for pulling out the gas sampling unit (approx. 2 m).
- ▶ Protect the line from damage (chafing through vibration, mechanical and thermal load).
- ▶ Observe a minimum bending radius of 300 mm.

1. Remove the enclosure cover (see "Weatherproof enclosure", page 13).
2. Unscrew the large cap nut and slide it onto the sample gas line.
3. Unscrew the insulation half-shell.
4. Feed the sample gas line through the large cable gland of the weatherproof enclosure and then through the installation plate and the hose clamp.
5. Screw the sample gas line tight on the clamping ring screw connection.
  - For first screwing (clamping ring still loose): 1¼ turn to "hand-tight".
  - For further screwing: (clamping ring tight) ¼ turn to "hand-tight".
6. Fasten the sample gas line using a hose clamp. The screw head can be reached via an opening in the chamfer of the installation plate.
7. Screw the insulation half-shell back on again.
8. Tighten the cap nut hand-tight.
9. Check hose connections for leaks:
 

The leak tightness check is performed via the connected measuring system: See the Operating Instructions of the measuring system.

### 4.4.3 Connection of the pneumatic lines



#### NOTICE

Risk of damaging the measuring system.

- Ensure correct assignment of the pneumatic connections.
- Ensure leak tightness of the system.

#### Connection for SFU-BF NI GL

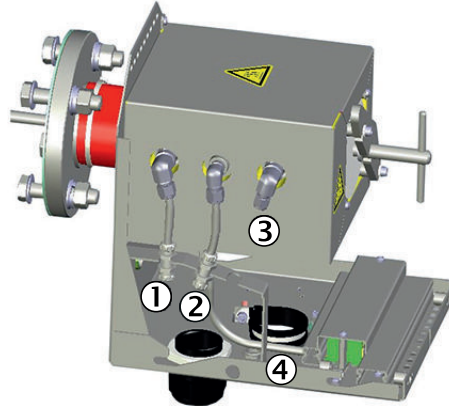

Figure 9: Connection of SFU-BF NI GL pneumatic lines

- ① Backflush
- ② Main valve
- ③ Zero gas
- ④ Installation plate

1. Push the cap nut onto the connection bundle.
2. Feed the connection bundle through the cable gland of the weatherproof enclosure and then through the installation plate.
3. Connect the 3 hoses with the 3 hose fittings on the filter housing and ensure correct layout.
4. Push the hoses flush over the hose connections of the hose fitting.
5. Hose for the zero gas: Use clamping ring screw connection with support sleeve.
6. Tighten the cap nut by hand.
7. Screw the cable gland tight.

#### 4.4.3.1 Adapter for inch thread (option)

If you want to connect pneumatic lines with inch thread: There is an adapter set with 4 clamping ring screw fittings.

Part No. "Adapter set inch thread": 2083838

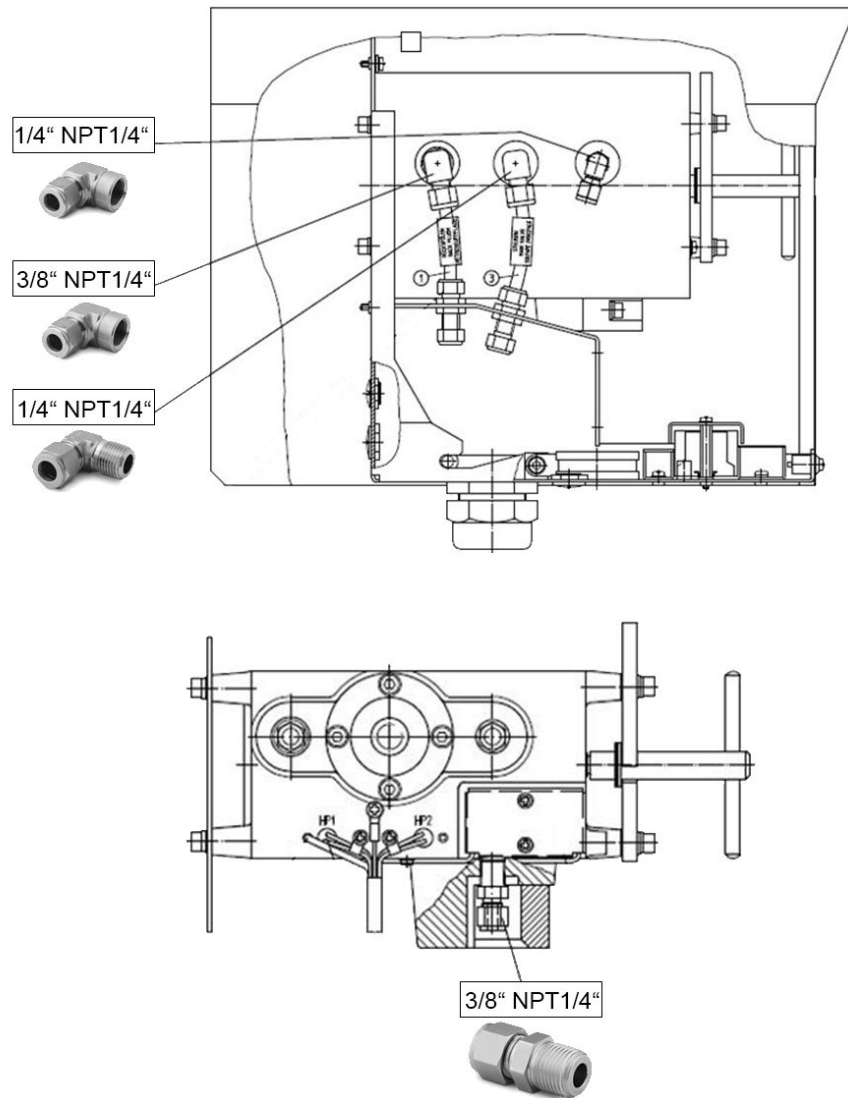

Figure 10: Adapter set

**Installation**

1. Wrap the thread with 2 - 2.5 layers of Teflon tape.
2. Tighten the adapter with an open-end wrench until a distinct increase in strength is felt.  
Then tighten by approx. 1/8 to 1/4 turn.

**4.5 Electrical installation**



**WARNING**

Danger to life by electric voltage

- ▶ Only allow an authorized electrician to work on the electric system.



**WARNING**

Risk of short-circuit due to condensate.

- ▶ Allow the electronics to acclimatize sufficiently before connecting.

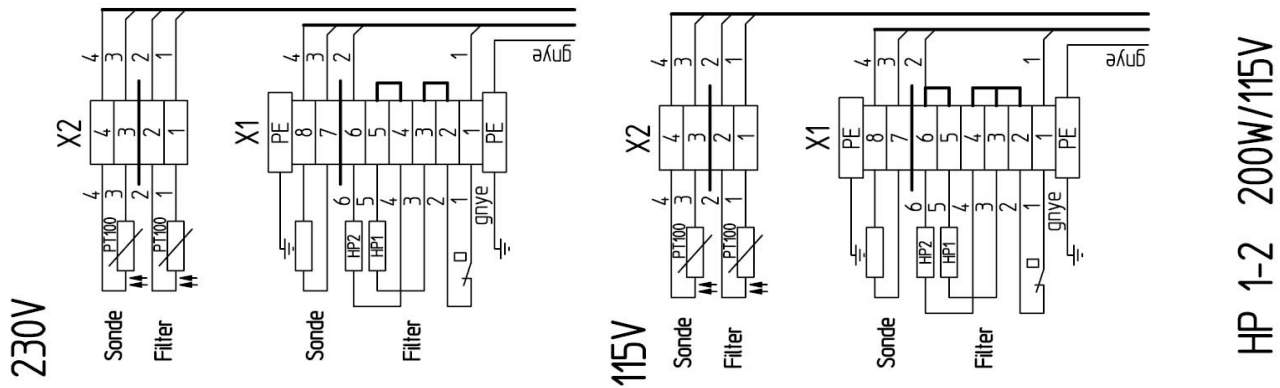

Figure 11: Terminal diagram for 230 V and 115 V

The electrical connection of the gas sampling unit is made via the connection terminals on the installation plate.

Observe the terminal diagram on the SFU.

The temperature sensors and the heating cartridges are wired ex factory.

- ▶ Remove the enclosure.
- ▶ Perform electrical connections.

### 4.6 Installing the gas sampling tube on the gas sampling unit

#### Installing the gas sampling tube

The gas sampling unit with gas sampling tube is supplied pre-assembled.

#### Installing the pre-filter

The pre-filter can be screwed to the gas sampling tube.

- 1 Wrap the thread with Teflon tape.
- 2 Screw the pre-filter onto the tip of the gas sampling tube. Tighten by hand with a wrench.

### 4.7 Installing the SFU on the welding neck flange



#### NOTICE

Risk of contamination of the gas sampling unit

Do not install a cold gas sampling unit on the stack.

- ▶ Allow the gas sampling unit to warm up before installing it on the welding neck flange.
- ▶ Warm-up time: Approx. 1.5 h at 25 °C ambient temperature

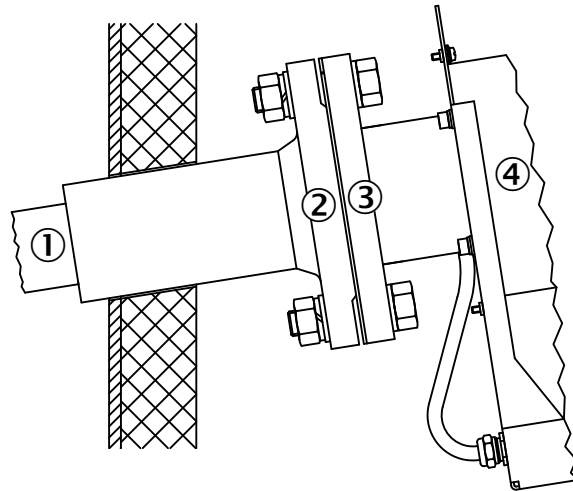

Figure 12: Installation of gas sampling tube on welding neck flange

- ① Gas sampling tube
- ② Welding neck flange
- ③ Filter housing flange
- ④ Filter housing



#### WARNING

Risk of burns on hot surfaces

The gas sampling tube and the gas sampling unit become hot during operation.

- ▶ Wear suitable protective clothing, e.g. heat-resistant gloves.

1. Push the seal over the gas sampling tube.
2. Push the gas sampling unit with probe tube into the welding neck flange.  
The hose outputs of the gas sampling unit have to point downwards.
3. Screw the filter housing flange of the gas sampling unit to the welding neck flange.
4. Fit the weatherproof enclosure: see "[Weatherproof enclosure](#)", page 13

## 5 Maintenance

### 5.1 Important Information



#### WARNING

Risk of injury by a heavy load

The weatherproof enclosure including the sampling system with flange weighs approx. 30 kg.

- ▶ Use proper lifting techniques to lift or move the device.
- ▶ Lift the unit by the enclosure. If necessary, remove the cover in order to grip the device better and reduce the weight.
- ▶ Always work in pairs.



#### WARNING

Health risk through dangerous sample gas

If dangerous sample gas is applied to the SFU: The operator is responsible for safe handling of sample gas.

- ▶ In addition to these Operating Instructions, observe all local laws, technical rules, and company-internal instructions valid at the site where the SFU is installed.
- ▶ Operate the SFU only in rooms with adequate installation OR install suitable gas monitoring equipment.
- ▶ Channel sample gas off safely.



#### WARNING

Hazard through sample gas pressure

The stacks can have underpressure or overpressure.

- ▶ Observe information from the plant operator.



#### WARNING

Risk of burns on hot surfaces

Filter housing, flanges and sample gas line can be hot.

- ▶ Allow the surface of the device parts to cool down to body temperature or wear suitable protective gloves.



#### WARNING

Danger to life by electric voltage

- ▶ Only allow an authorized electrician to work on the electric system.



### 5.2 Maintenance plan

No.	Maintenance work	Reference	Interval
W1	Replace sintered metal filter element and seals	see <a href="#">"Replacing the sintered metal filter element"</a> , page 23	3M <sup>1</sup>
W2	Replace glass fiber filter element and seals	see <a href="#">"Replacing the glass fiber filter element"</a> , page 26	3M <sup>1</sup>
W3	Check gas connections	see <a href="#">"Checking for correct operation"</a> , page 32	3M <sup>1</sup>

<sup>1</sup> 3M = every 3 months

No.	Conversion	Reference	Interval
U1	Change from sintered metal to glass fiber filter element	see "Retrofitting the filter element", page 29	-

### 5.3 Spare parts

Required spare parts for W1 and W2	Part number	Quantity required	Picture
Service kit (contains: 1*2 µm sintered metal filter element, 2*flat seals, 1*O-ring)	2039002	1	
Service kit (contains 1*0.1µm glass fiber filter element, 1*flat seal, 1*O-ring)	2043616	1	

Required spare parts for U1	Part number	Quantity required	Picture
Glass fiber filter element with holder (contains 1*0.1µm glass fiber filter element, adapter, 1*flat seal, 1*O-ring)	2024972	1	



**NOTE**

Further spare parts can be found in the individual System Description provided with the gas sampling unit.

### 5.4 Replacing the sintered metal filter element

You can perform the work while the filter element is hot.

Pay attention to the warning about hot surfaces.

The filter element may be hot inside.



**WARNING**

Risk of burns on hot surfaces

The filter element can reach high temperatures in operation.

- ▶ Wear suitable gloves.
- ▶ Provide a heat-resistant support.



**WARNING**

Hazard by toxic substances

Filter elements can contain toxic substances depending on the sample gas composition.

- ▶ Observe the relevant safety regulations.
- ▶ Dispose of the filter elements in an environmentally compatible manner.

### Procedure

1. Switch off the fuse of the gas sampling unit in the measuring system.  
The position of the fuse is described in the System Documentation enclosed with the measuring system.
2. Remove the enclosure: see ["Weatherproof enclosure"](#), page 13.
3. Check all gas connections:
  - Optical condition
  - Tight seat
  - Leak tightness:  
The leak tightness check is performed via the connected measuring system:  
See the Operating Instructions of the measuring system.

### Changing the sintered metal filter element

1. Loosen the rotary handle counterclockwise.

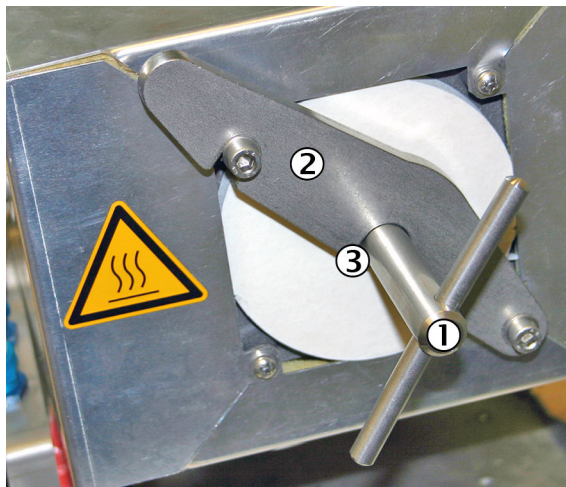

- ① Rotary handle
- ② Mounting bracket
- ③ Pressure disk (covered)

2. Swing the mounting bracket to the right.



#### WARNING

Risk of burns on hot surfaces

The inner parts of the gas sampling filter can be especially hot.

- ▶ Wear suitable gloves.
- ▶ Provide a heat-resistant support.



#### CAUTION

Risk of injury due to high weight

- ▶ Do not drop the filter cover.

3. Pull the filter cover out using the rotary handle.
4. If the filter cover is hot: Place the filter cover on a heat-resistant mat.
5. Remove the sintered metal filter element.



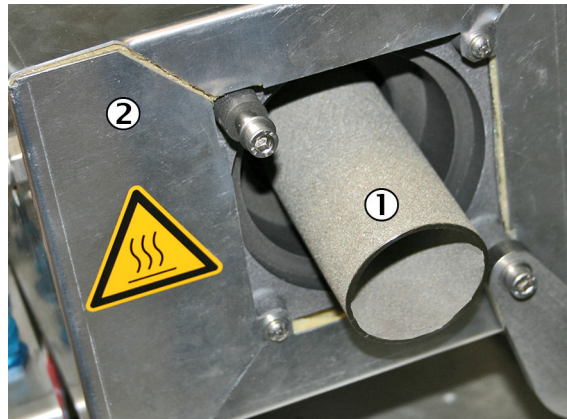

- ① Sintered metal filter element
- ② Filter housing

6. Pull out the bottom flat seal with a hook.
7. Insert new bottom flat seal.

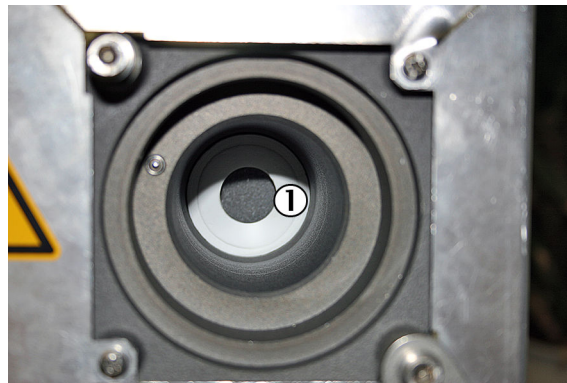

- ① Bottom flat seal

8. Replace O-ring and flat seal of the filter cover.

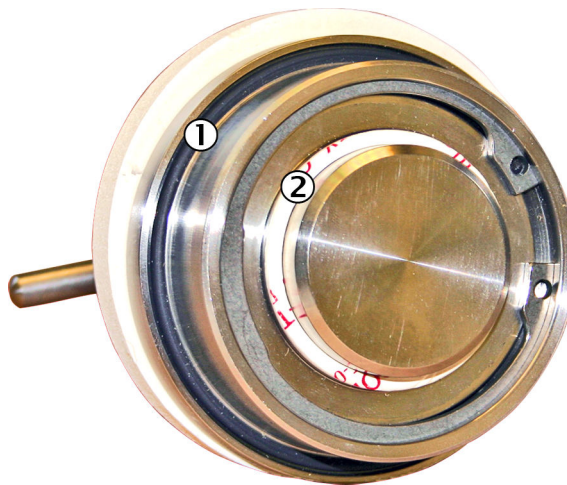

- ① O-ring
- ② Flat seal

9. Insert new or cleaned filter element.  
If one side of the filter element has a groove: The groove must point in the direction of the filter cover.

10. Fit the filter cover.
11. Swing back the mounting bracket. Make sure that the pressure disk is behind the mounting bracket.

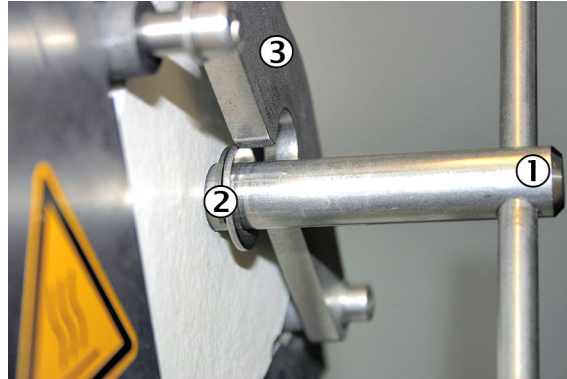

- ① Rotary handle
- ② Pressure disk
- ③ Mounting bracket

12. Tighten the rotary handle clockwise.
13. Fit the enclosure again: [see "Weatherproof enclosure", page 13.](#)

### 5.5 Replacing the glass fiber filter element

You can perform the work while the filter element is hot.

Pay attention to the warning about hot surfaces.

The filter can have an internal temperature of 185 °C.



#### **WARNING**

Risk of burns on hot surfaces

The filter element can reach high temperatures in operation.

- ▶ Wear suitable gloves.
  - ▶ Provide a heat-resistant support.
- 



#### **WARNING**

Hazard by toxic substances

Filter elements can contain toxic substances depending on the sample gas composition.

- ▶ Observe the relevant safety regulations.
  - ▶ Dispose of the filter elements in an environmentally compatible manner.
- 

#### **Replacing fine filter cartridge**

1. Loosen the rotary handle counterclockwise.

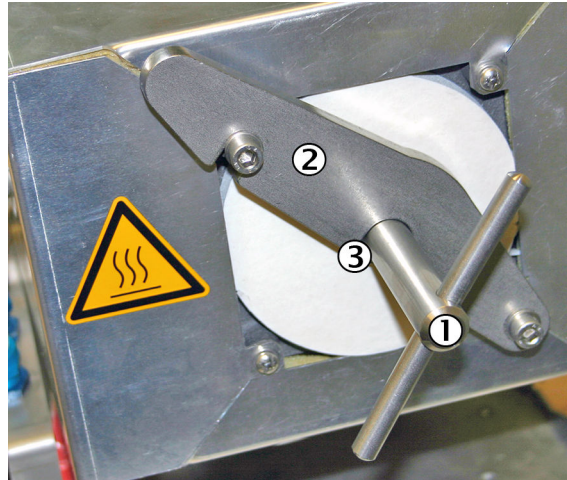

- ① Rotary handle
- ② Mounting bracket
- ③ Pressure disk (covered)

2. Swing the mounting bracket to the right.



**WARNING**

Risk of burns on hot surfaces

The filter element can reach high temperatures in operation.

- ▶ Wear suitable gloves.
- ▶ Provide a heat-resistant support.



**CAUTION**

Risk of injury due to high weight

- ▶ Do not drop the filter cover.

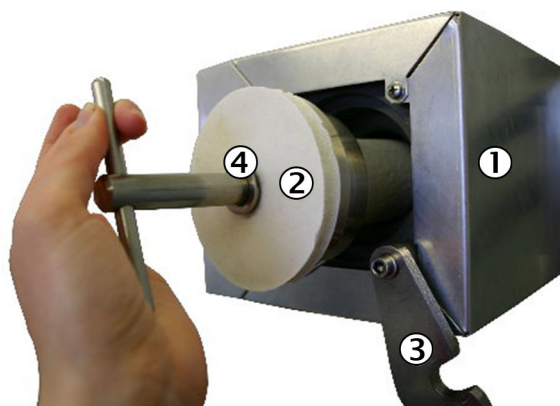

- ① Filter housing
- ② Filter cover
- ③ Mounting bracket
- ④ Pressure disk

- 3. Pull out the filter cover with glass fiber filter element using the rotary handle.
- 4. If the filter cover is hot: Place the filter cover on a heat-resistant mat.
- 5. Pull out the bottom flat seal with a hook.

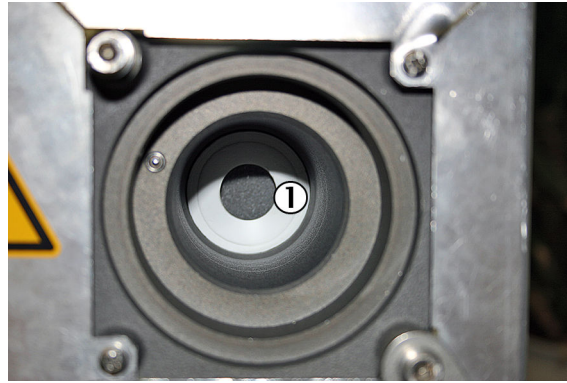

① Bottom flat seal

6. Loosen the glass fiber filter element from the filter handle by opening the spiral thread.

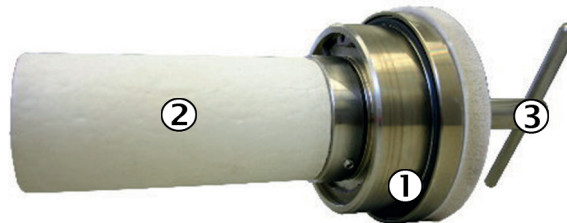

① O-ring  
 ② Glass fiber filter element  
 ③ Rotary handle

7. Insert new bottom flat seal.
8. Renew the O-ring in the filter cover.
9. Fit new or cleaned glass fiber filter element on the filter cover. Tighten the spiral thread.
10. Replace the filter cover.

If one side of the filter element has a groove: The groove must point in the direction of the filter cover.

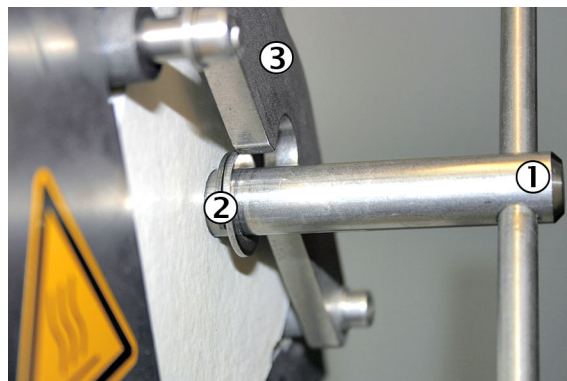

① Rotary handle  
 ② Pressure disk  
 ③ Mounting bracket

11. Swing back the mounting bracket. Make sure that the pressure disk is behind the mounting bracket.

12. Tighten the rotary handle clockwise.
13. Fit the housing again: see "[Weatherproof enclosure](#)", page 13.

## 5.6 Retrofitting the filter element

You can perform the work while the filter element is hot.

Pay attention to the warning about hot surfaces.

The filter can have an internal temperature of 185 °C.



### WARNING

Risk of burns on hot surfaces

The filter element can reach high temperatures in operation.

- ▶ Wear suitable gloves.
- ▶ Provide a heat-resistant support.



### WARNING

Hazard by toxic substances

Filter elements can contain toxic substances depending on the sample gas composition.

- ▶ Observe the relevant safety regulations.
- ▶ Dispose of the filter elements in an environmentally compatible manner.

### Procedure

1. Switch off the fuse of the gas sampling unit in the measuring system.  
The position of the fuse is described in the System Documentation enclosed with the measuring system.
2. Remove the enclosure: see "[Weatherproof enclosure](#)", page 13.
3. Check all gas connections:
  - Optical condition
  - Tight seat
  - Leak tightness:  
The leak tightness check is performed via the connected measuring system:  
See the Operating Instructions of the measuring system.

### Retrofitting the sintered metal filter element to a glass fiber filter element

1. Loosen the rotary handle counterclockwise.

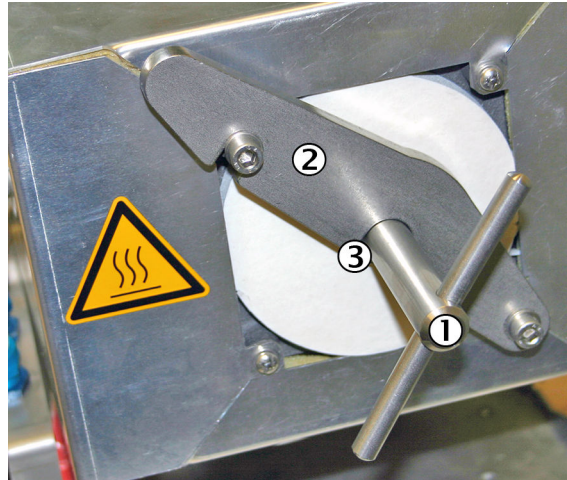

- ① Rotary handle
- ② Mounting bracket
- ③ Pressure disk (covered)

2. Swing the mounting bracket to the right.



### WARNING

Risk of burns on hot surfaces

The filter element can reach high temperatures in operation.

- ▶ Wear suitable gloves.
- ▶ Provide a heat-resistant support.



### CAUTION

Risk of injury due to high weight

- ▶ Do not drop the filter cover.

3. Pull the filter cover out using the rotary handle.
4. If the filter cover is hot: Place the filter cover on a heat-resistant mat.
5. Remove the sintered metal filter element.

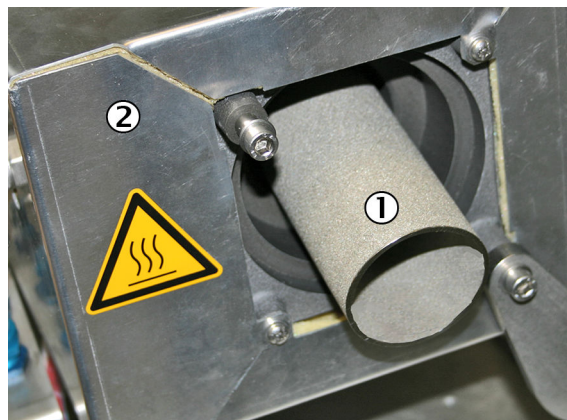

- ① Sintered metal filter element
- ② Filter housing

6. Pull out the bottom flat seal with a hook.
7. Insert new bottom flat seal.

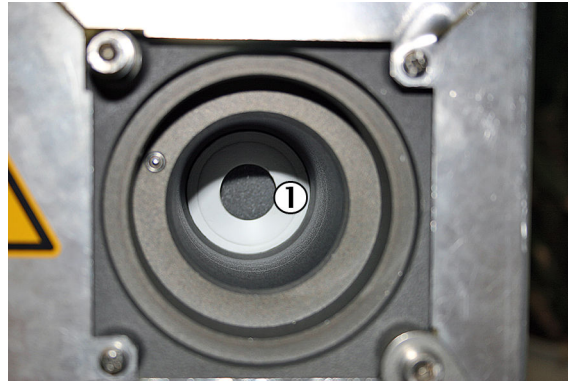

① Bottom flat seal

8. Replace O-ring and flat seal of the filter cover.

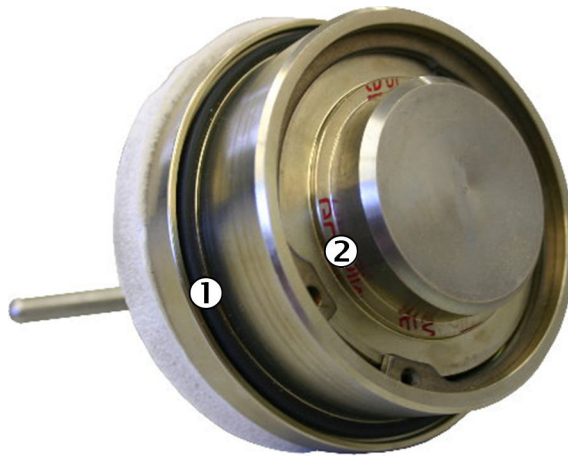

① O-ring  
② Position of flat seal

9. Fit the glass fiber filter element on the filter cover. Tighten with the spiral thread. If one side of the glass fiber filter element has a groove: The groove must point in the direction of the filter cover.

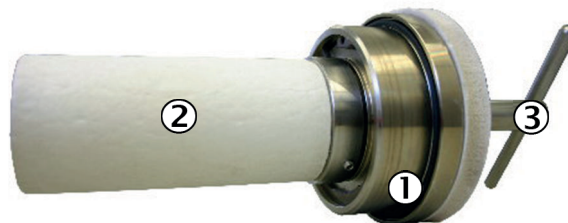

① O-ring  
② Glass fiber filter element  
③ Rotary handle

10. Replace the filter cover.  
11. Swing back the mounting bracket. Make sure that the pressure disk is behind the mounting bracket.

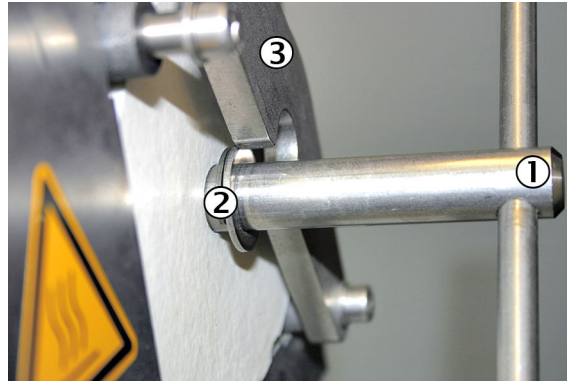

- ① Rotary handle
- ② Pressure disk
- ③ Mounting bracket

12. Tighten the rotary handle clockwise.
13. Fit the enclosure again: [see "Weatherproof enclosure", page 13](#)

### 5.7 Checking for correct operation

- Check all fastening screws of the housing for tight seat.
- Check the sample gas line for damage.
- Check all hose fittings for tight seat.
- Check gas sampling unit for cleanness, dryness and freedom from corrosion.
- Check all electric connections for freedom from corrosion and tight seat.
- Check grounding conductors are free from corrosion.
- Perform a leak tightness check:  
The leak tightness check is performed via the connected measuring system: See the Operating Instructions of the measuring system.



## 6 Troubleshooting

### 6.1 Troubleshooting

Fault	Possible cause	Correction
Gas throughput decreases	Pre-filter contaminated	Clean or replace
	Filter element contaminated	
Heating failed	Heating cartridge or temperature sensor defective	If necessary, replace seal or defective component
	Defective seal	Replace seal
Contaminated or corroded gas paths	Defective or missing pre-filter	Replace
Leaky non-return valves	Contaminated instrument air	Replace Check the purity of the instrument air
Leaky main valve	Valve seating contaminated or damaged	Replace the valve cone Replace the filter housing
	Metal bellow leaky	Replace the metal bellow

### 7 Disposal

The device can easily be disassembled into its components which can then be sent to the respective raw material recycling facilities.

---



#### **WARNING**

Filters and lines with sample gas contact can contain toxic substances.

Observe the relevant safety regulations.

- ▶ Depending on their components, filters and lines with sample gas contact must be disposed of according to the legal regulations. If required, they must be treated as hazardous waste.
-

## 8 Technical data

### 8.1 Compliances and Standards

#### Compliance

The technical version of device SFU-BF NI GL complies with the following EU directives and EN standards:

- EC Directive: LVD (Low Voltage Directive)  
EN 61010-1: Safety requirements for electrical equipment for measurement, control and laboratory use

Further standards: See Declaration of Conformity provided with the device

#### Additional standards for SFU-BF NI GL

- MARPOL Annex VI and NTC 2008 - MEPC.177(58)
- Guidelines for exhaust gas cleaning systems - MEPC.184(59)
- DNV GL Rules for Classification and Construction, Part VI Additional Rules and Guidelines Chapter 7, Guidelines for the Performance of Type Approvals, Test Requirements for Electrical / Electronic Equipment and Systems (2012)

### 8.2 Dimensions

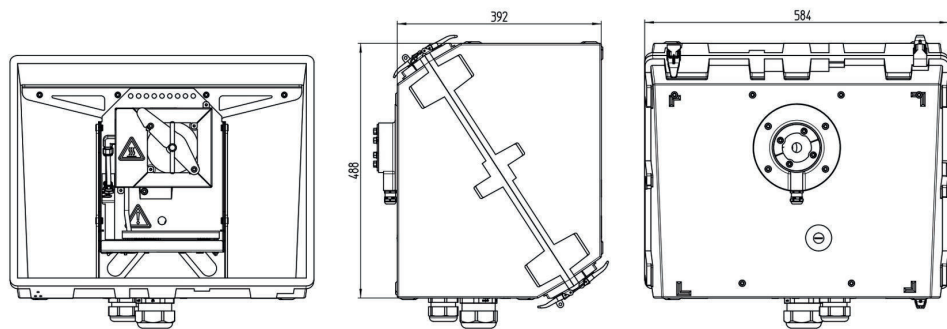

Figure 13: SFU-BF NI GL in weatherproof enclosure

### 8.3 Operating data

Ambient conditions	SFU-BF NI GL in weatherproof enclosure
Ambient temperature	-35 ... +55 °C (-31 ... +131 °F)
Storage temperature	-40 ... +60 °C (-40 ... 140 °F)
Relative humidity	Max. 95%
Degree of protection	IP54
Installation	SFU-BF NI GL in weatherproof enclosure
Tubing SFU-BF NI GL	Dimensions:
<ul style="list-style-type: none"> <li>• Main valve</li> <li>• Zero gas</li> <li>• Backflush</li> <li>• Sample gas line</li> </ul>	<ul style="list-style-type: none"> <li>• 8 mm</li> <li>• 6 mm</li> <li>• 8 mm</li> <li>• 6 mm</li> </ul>

Installation		SFU-BF NI GL in weatherproof enclosure		
Compressed air	<ul style="list-style-type: none"> <li>• Main valve</li> <li>• Zero gas</li> <li>• Backflush</li> </ul>	Pressure:		
		<ul style="list-style-type: none"> <li>• 5 - 6 bar (500 - 600 kPascal)</li> <li>• 2.5 - 3 bar (250 - 300 kPascal)</li> <li>• 5 - 6 bar (500 - 600 kPascal)</li> </ul>		
Flange NW = Rated width ND = Rated pressure		NW 65 ND 6		
Fitting position		Horizontally with an inclination of approx. 10° (see "Installing the welding neck flange", page 15)		
Power input		SFU-BF NI GL in weatherproof enclosure		
probe filter		115/230 V, 50-60 Hz, max. 450 VA		
Device characteristics		SFU-BF NI GL in weatherproof enclosure		
Materials	<ul style="list-style-type: none"> <li>• Gas sampling tube</li> <li>• IP54 enclosure</li> <li>• Locks</li> <li>• Seals</li> </ul>	Materials		
		<ul style="list-style-type: none"> <li>• Application-dependent; maritime unheated gas sampling tubes: 1.4547/254 SMO</li> <li>• GRP enclosure (glass fiber reinforced plastic)</li> <li>• Tension locks: Stainless steel</li> <li>• EPDM/silicone</li> </ul>		
Weight		Approx. 30 kg (SFU in IP54 enclosure with flange and gas sampling tube)		
Gas temperature in sampling system		Max. 250 °C (482 °F)		
Gas temperature in stack		Unheated gas sampling tube: Max. 1300 °C (2400 °F) Heated gas sampling tube: Max. 200 °C (392 °F)		
Heating temperature of the SFU		Max. 200 °C (392 °F)		
Temperature control		External, Pt100		
Limit monitoring		External heating controller		
Purge gas flow		Approx. 12 l/min		
Backpurge flow rate		Approx. 80 l/min		
Sample gas throughput		300 ... 1000 l/h		
Heating up time		Approx. 1,5 h (from room temperature to 200 °C)		
Standard lengths of unheated maritime gas sampling tubes [mm]; Material 1.4547/254 SMO				
500		800		
Standard lengths of heated gas sampling tubes [mm]; Material 1.4404				
500	800	1000	1500	2000



**Australia**

Phone +61 (3) 9457 0600  
1800 33 48 02 – tollfree  
E-Mail sales@sick.com.au

**Austria**

Phone +43 (0) 2236 62288-0  
E-Mail office@sick.at

**Belgium/Luxembourg**

Phone +32 (0) 2 466 55 66  
E-Mail info@sick.be

**Brazil**

Phone +55 11 3215-4900  
E-Mail comercial@sick.com.br

**Canada**

Phone +1 905.771.1444  
E-Mail cs.canada@sick.com

**Czech Republic**

Phone +420 234 719 500  
E-Mail sick@sick.cz

**Chile**

Phone +56 (2) 2274 7430  
E-Mail chile@sick.com

**China**

Phone +86 20 2882 3600  
E-Mail info.china@sick.net.cn

**Denmark**

Phone +45 45 82 64 00  
E-Mail sick@sick.dk

**Finland**

Phone +358-9-25 15 800  
E-Mail sick@sick.fi

**France**

Phone +33 1 64 62 35 00  
E-Mail info@sick.fr

**Germany**

Phone +49 (0) 2 11 53 010  
E-Mail info@sick.de

**Greece**

Phone +30 210 6825100  
E-Mail office@sick.com.gr

**Hong Kong**

Phone +852 2153 6300  
E-Mail ghk@sick.com.hk

**Hungary**

Phone +36 1 371 2680  
E-Mail ertekezes@sick.hu

**India**

Phone +91-22-6119 8900  
E-Mail info@sick-india.com

**Israel**

Phone +972 97110 11  
E-Mail info@sick-sensors.com

**Italy**

Phone +39 02 27 43 41  
E-Mail info@sick.it

**Japan**

Phone +81 3 5309 2112  
E-Mail support@sick.jp

**Malaysia**

Phone +603-8080 7425  
E-Mail enquiry.my@sick.com

**Mexico**

Phone +52 (472) 748 9451  
E-Mail mexico@sick.com

**Netherlands**

Phone +31 (0) 30 229 25 44  
E-Mail info@sick.nl

**New Zealand**

Phone +64 9 415 0459  
0800 222 278 – tollfree  
E-Mail sales@sick.co.nz

**Norway**

Phone +47 67 81 50 00  
E-Mail sick@sick.no

**Poland**

Phone +48 22 539 41 00  
E-Mail info@sick.pl

**Romania**

Phone +40 356-17 11 20  
E-Mail office@sick.ro

**Russia**

Phone +7 495 283 09 90  
E-Mail info@sick.ru

**Singapore**

Phone +65 6744 3732  
E-Mail sales.gsg@sick.com

**Slovakia**

Phone +421 482 901 201  
E-Mail mail@sick-sk.sk

**Slovenia**

Phone +386 591 78849  
E-Mail office@sick.si

**South Africa**

Phone +27 10 060 0550  
E-Mail info@sickautomation.co.za

**South Korea**

Phone +82 2 786 6321/4  
E-Mail infokorea@sick.com

**Spain**

Phone +34 93 480 31 00  
E-Mail info@sick.es

**Sweden**

Phone +46 10 110 10 00  
E-Mail info@sick.se

**Switzerland**

Phone +41 41 619 29 39  
E-Mail contact@sick.ch

**Taiwan**

Phone +886-2-2375-6288  
E-Mail sales@sick.com.tw

**Thailand**

Phone +66 2 645 0009  
E-Mail marcom.th@sick.com

**Turkey**

Phone +90 (216) 528 50 00  
E-Mail info@sick.com.tr

**United Arab Emirates**

Phone +971 (0) 4 88 65 878  
E-Mail contact@sick.ae

**United Kingdom**

Phone +44 (0)17278 31121  
E-Mail info@sick.co.uk

**USA**

Phone +1 800.325.7425  
E-Mail info@sick.com

**Vietnam**

Phone +65 6744 3732  
E-Mail sales.gsg@sick.com

Detailed addresses and further locations at [www.sick.com](http://www.sick.com)

