

Gas Density Monitor (GDM) with Attached Gas Density Transmitter Model 233.52.100 TA

WIKA Data Sheet SP 60.06

Applications

- Gas density monitoring of closed SF₆ tanks
- For indoor and outdoor installation in SF₆-gas-isolated switching units

Special Features

Modified bourdon tube pressure gauge with Gas Density Transmitter attached to the outside connection of the case

- Local readout with alarm contacts
- Remote readout (output 4 ... 20 mA, 2-wire system), measuring ranges from 0 ... 10 g/liter to 0 ... 80 g/liter
- High EMI performance, CE-conformity
- Hermetically sealed, therefore no influence by atmospheric pressure fluctuation and differences in altitude

Description - Gas Density Transmitter

Model 233.52.100 TA features a Gas Density Transmitter attached to the side of the Gas Density Monitor's pressure connection. It functions fully as a standard GD-10 Gas Density Transmitter, however, the combination allows for both instruments to obtain a density reading through a single connection to the tank. WIKA transmitter GD-10 L (with L-plug connection) is shown in the drawing below, however GD-10 C (with attached cable) or GD-10 F (with robust field case) can also be used.

The gas density transmitter is electrically compensated following the non-linear behavior of SF₆-gas according to the virial equation. This provides the highest accuracy and best temperature compensation possible since SF₆ is a real gas functioning according to real gas law equations. Only a gas density transmitter can take this into account.

The gas density transmitter picks up the pressure and temperature of the SF₆-gas contained in the tank.

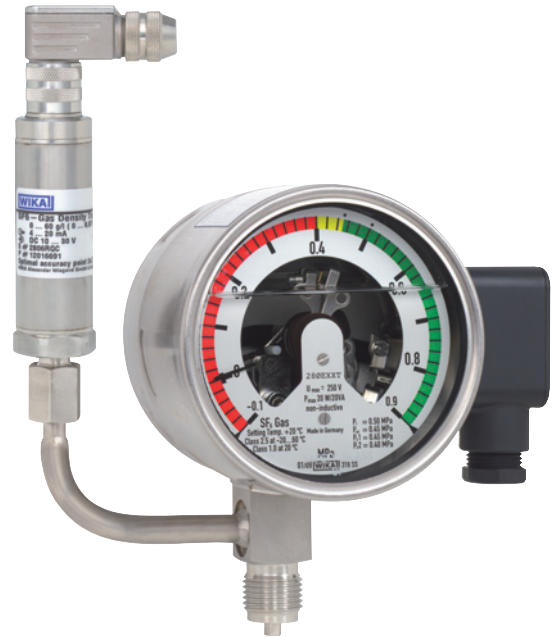

Gas Density Monitor (GDM) with Attached Gas Density Transmitter, Model 233.52.100 TA

The current gas density is ascertained from both variables by means of an electronic evaluation system. Thermal induced pressure changes are dynamically compensated and do not affect the output signal.

The gas density transmitter generates a density proportional standardized signal of 4 ... 20 mA (2-wire system) and measures ranges from 0 ... 10 g/liter to 0 ... 80 g/liter.

Recalibration of the zero signal is not necessary due to the high long-term stability of the gas density transmitter. The hermetically-sealed measuring cell guarantees high long-term leak tightness. It is welded closed to prevent leaks and remain independent of atmospheric pressure fluctuations and variations of the mounting height.

The EMI properties of the transmitter are tested according to IEC 61000-4-2 thru IEC 61000-4-6 and guarantee a safe pick-up of the signal which is especially suited to conditions prevailing in high-voltage switching units.

Description - Gas Density Monitor

Nominal size

100 mm dial size with transmitter attached

Accuracy (relating to the measuring span)

Accuracy of $\pm 1\%$ at $+20\text{ °C}/68\text{ °F}$ ($\pm 0.37\%/10\text{ °K}$ must be added as the temperature deviates from $+20\text{ °C}/68\text{ °F}$)

- Reference diagram KALI-Chemie AG
- Calibration pressure is used as reference isochore

Scale ranges

All standard ranges and +/- ranges with a measuring span of min. 1.6 bar und max. 25 bar (SF_6 gas pressure at $+20\text{ °C}$)

Calibration pressure P_E

As ordering specifications

Permissible temperatures

Ambient: $-20 \dots +60\text{ °C}$ (gas phase)

Storage: $-50 \dots +60\text{ °C}$

Alarm contacts / Contact rating

- Max. 3 magnetic snap-action contacts, to make or break, with galvanic isolation, switching points non-adjustable and secured
- Contact rating: 20 W / 20 VA, max. 1 A
- Material of contacts: 80 % Ag / 20 % Ni, gold-plated
- Alarm contacts with excellent long-term stability

Switching accuracy in temperature range $-20 \dots +60\text{ °C}$

If switching point is equal P_E : as measuring span,

If switching point is not equal P_E :

Moved parallel to calibration pressure

High-voltage test

2 kV, 50 Hz, 1 s (wiring versus case)

Electrical connection

Cable box with cable gland M20 x 1.5

Connection cross-section max. 2.5 mm²

Pressure connection

Stainless steel,

Lower mount (LM),

spigot $\text{Ø} 6 \times 5$, similar to EN 837,

G ½ B (male), 22 mm flats

Pressure element

Stainless steel, welded

Gas tight: leakage rate $\leq 1 \cdot 10^{-8}$ mbar · l / s

Test method: spectrometry of helium mass

Movement

Stainless steel

Bimetal link (temperature compensation)

Dial

Aluminium, red-green-yellow section as ordering specifications

Pointer

Aluminium, black

Case

- Stainless steel with silicone oil or dry nitrogen filling
- Hermetically sealed to prevent influence by atmospheric pressure fluctuation and differences in altitude
- Gas tight: leakage rate $\leq 1 \cdot 10^{-5}$ mbar · l / s

Window

Laminated safety glass

Bezel ring

Cam ring (bayonet type), stainless steel secured with 3 welding spots

Ingress protection

IP 65 per EN 60 529 / IEC 529

Weight

approx. 1.2 kg

Options - Gas Density Monitor

- 3 magnetic snap-action contacts, without galvanic
- Isolation, switching points are adjustable
- Acrylic glass window
- Pressure connection through flanges
- Back connection
- Pluggable cable box

Dimensions in mm

Standard version

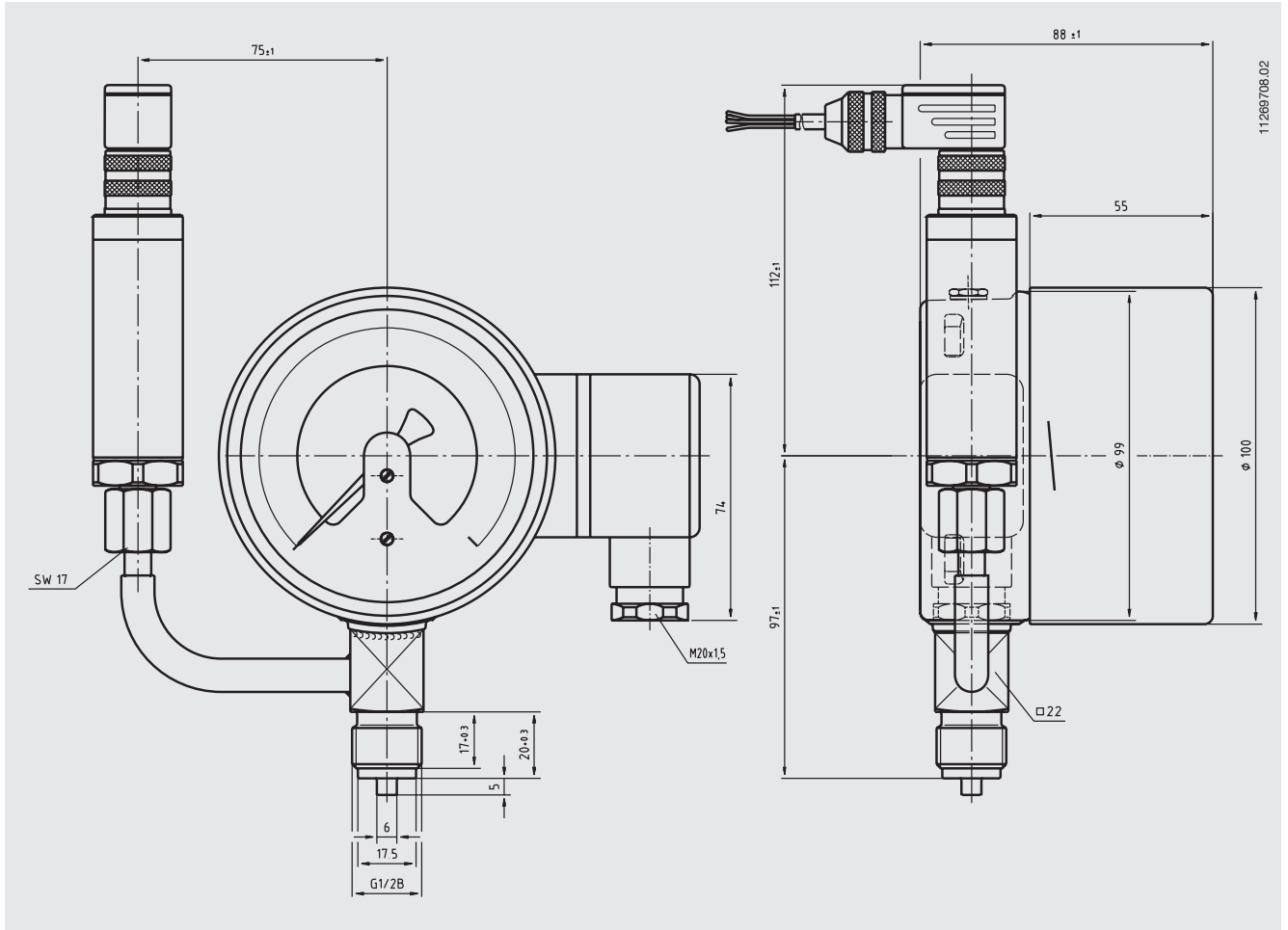

Specifications for Gas Density Transmitter

Designed for Sensing principle		pure SF ₆ -gas piezoresistive					
Density ranges (Pressure ranges)	g/Litre bar _{abs.} at 20 °C	10 1.64	16 2.59	25 3.97	40 6.16	60 8.87	80 11.33
Over pressure safety	bar _{abs.}	14	14	14	29	29	67
Burst pressure of sensor	bar _{abs.}	17	17	17	35	35	80
Pressure reference		absolute pressure					
Materials							
Wetted parts		stainless steel					
Case / terminal case		stainless steel					
Internal transmitting fluid		synthetic oil					
Power supply U _B	DC V	10 < U _B ≤ 30					
Signal output and maximum load R _A		4 ... 20 mA, 2-wire, R _A ≤ (U _B -10 V) / 0.02 A with R _A in Ohm and U _B in Volt					
Accuracy	% of span	-40 °C.: 3% / 20 °C.: 1% / 60 °C.: 2.3% (optimal accuracy point) -40 °C.: 4% / 20 °C.: 2% / 60 °C.: 3.3% (beginning and end of measuring range)					
1-year stability	% of span	≤ 0.3 (at reference conditions)					
Nominal temperature	°C (°F)	-40 ... +60 (-40 ... +140) [gas phase!]					
Working temperature range	°C (°F)	-40 ... +80 (-40 ... +176) [gas phase!]					
Storage temperature	°C (°F)	-40 ... +80 (-40 ... +176)					
CE - conformity		EN 61 326					
High voltage strength	DC V	750 (wiring versus case)					
Electro-magnetic immunity (EMI) / RFI		IEC 61000-4-2 (ESD): test level 4 (8 kV)					
per IEC 61000-4		IEC 61000-4-3 (Field): test level 3 (10 V/m)					
		IEC 61000-4-4 (Burst): test level X (+/-4 kV)					
		IEC 61000-4-5 (Surge): test level 2 (+/-1 kV)					
		IEC 61000-4-6 (Conducted RFI): test level 3 (10 V)					
Cable gland and Ingress protection per EN 60529 / IEC 529		2-pin plug, IP 67 {L-junction box brass, nickel-plated, IP 67} {cable gland with flying lead 1.5 m; IP 68}					
Wiring protection		Protected against reverse polarity and overvoltage					

Items in curved brackets { } are optional extras for additional price.

Modifications may take place and materials specified may be replaced by others without prior notice.
Specifications and dimensions given in this leaflet represent the state of engineering at the time of printing.

