

Liquisys M

CLM 223 / 253

Transmitter for Conductivity

Operating Instructions

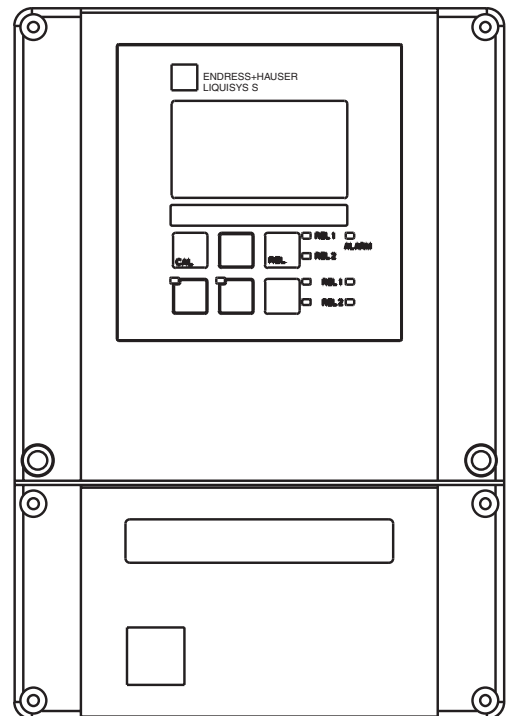
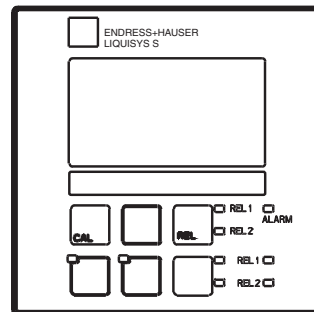

You want to find out about the device.
Just look here:



1

General information



2

Safety

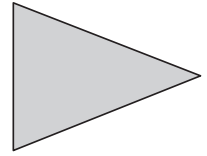

You wish to install the device.
The required steps are described in this chapter:



3

Installation

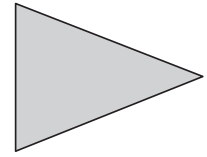

You wish to operate or reconfigure the device.
The operating concept is explained in these chapters:



4

Operation



5

Device configuration



6

Interfaces

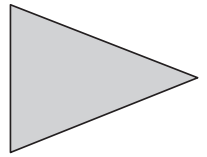

If faults occur or maintenance is required, look here
for help:



7

Maintenance and troubleshooting



8

Diagnostics and corrective maintenance

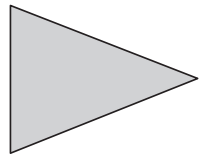

9

Accessories



10

Technical data



11

Appendix



12

Index

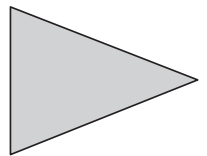

Table of contents

1	General information	2
1.1	Symbols used	2
1.2	Storage and transport	2
1.3	Unpacking	2
1.4	Dismantling, packaging and disposal	2
1.5	Product structure	3
2	Safety instructions	4
2.1	Intended application	4
2.2	General Safety notes	4
2.3	Installation, start-up, operation	4
2.4	Monitoring and safety features	5
2.5	Immunity to interference	5
2.6	Certificate of conformity	5
3	Installation	6
3.1	Measuring system	6
3.2	Dimensions	7
3.3	Mounting	8
3.4	Electrical connection	12
3.5	Measuring cell installation and cable connection	14
4	Operation	16
4.1	Operator interface	16
4.2	Display	16
4.3	Key functions	17
4.4	Auto / manual mode of operation	18
4.5	Operating concept	19
5	Instrument configuration	22
5.1	Start-up	24
5.2	System configuration	24
5.3	Current outputs	26
5.4	Monitoring functions	28
5.5	Relay contact configuration	31
5.6	Temperature compensation	42
5.7	Concentration measurement	44
5.8	Service	46
5.9	E+H Service	48
5.10	Interfaces	48
5.11	Calibration	49
6	Interfaces	52
7	Maintenance and troubleshooting	53
7.1	Troubleshooting common problems	53
7.2	Troubleshooting using the error messages	57
8	Diagnosis and corrective maintenance	59
8.1	Diagnosis	59
8.2	Corrective maintenance of Liquisys M CLM 223	61
8.3	Corrective maintenance of Liquisys M CLM 253	64
8.4	Spare parts orders	67
8.5	Service equipment »Optoscope« with »Scopeware«	67
8.6	Corrective maintenance of measuring system	68
9	Accessories	71
10	Technical data	73
11	Appendix	76
12	Index	80

1 General information

1.1 Symbols used



Warning:

This symbol alerts to hazards which could cause serious injuries as well as damage to the equipment if ignored.



Caution:

This symbol alerts to possible faults which could arise from incorrect operation. They could cause damage to the equipment if ignored.



Note:

This symbol indicates important items of information.



Double insulation

Equipment protected by double insulation.



Alarm relay



Input



Output

1.2 Storage and transport

The packaging material used to store or transport the transmitter must provide shock protection. Optimal protection is provided by the original packaging materials.

Conformance with the ambient conditions (see Technical data) must be assured.

1.3 Unpacking

Verify that the packaging and contents are undamaged! Inform the post office or freight carrier of any damage. Damaged merchandise must be retained until the matter has been settled.

Keep the original packaging materials for future storage or shipping of the instrument.

Check that the delivery is complete and agrees with the shipping documents and your order (refer to nameplate for type and version).

If you have any questions, consult your supplier or the Endress+Hauser sales agency for your area (see back cover of these Operating Instructions for addresses).

The delivery includes:

- Transmitter CLM 223 (panel-mounted instrument) or CLM 253 (field instrument)
- Operating instructions BA 193C/07/en
- Panel-mounted instrument:
 - 1 set of plug-in screw terminals
 - 2 clamping screws for panel mounting
- Field instrument:
 - 1 plug-in screw terminal
 - 1 x cable gland Pg 7
 - 1 x cable gland Pg 16, reduced
 - 2 x cable glands Pg 13.5
 - 1 x NPT adapter set (optional for CSA versions)

1.4 Dismantling, packaging and disposal

Package the assembly properly for reuse at a later point in time. Optimal protection is

provided by the original packaging materials. Observe local regulations for disposal.

1.5 Product structure

You can identify the instrument version by the order code on the nameplate. Sub “codes” are the release codes for Software upgrade

shown for Chemoclean (left of diagonal line) or Plus package (right of diagonal line).

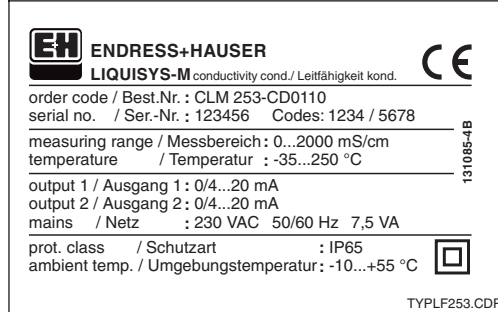
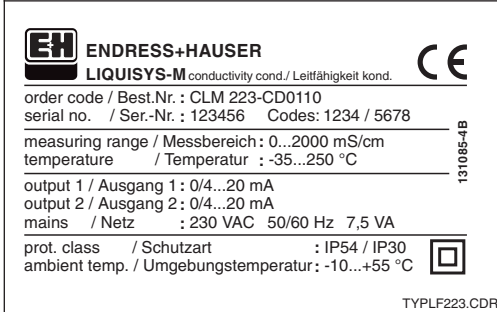

Fig. 1.1 Nameplate CLM 223 (left)

Fig. 1.2 Nameplate CLM 253 (right)

Liquisys M CLM 223 / 253																	
<p>Version</p> <p>CD Conductivity/resistance measurement (Two-electrode sensor)</p> <p>CS Conductivity/resistance measurement (Two-electrode sensor) with additional functions (Plus package)</p> <p>ID Conductivity measurement (inductive sensor)</p> <p>IS Conductivity measurement (ind. sensor) with additional functions (Plus package)</p> <p>Power supply</p> <p>0 Power supply 230 V AC</p> <p>1 Power supply 115 V AC</p> <p>2 Power supply 230 V AC, CSA Gen. Purp.</p> <p>3 Power supply 115 V AC, CSA Gen. Purp.</p> <p>5 Power supply 100 AC</p> <p>7 Power supply 24 AC, CSA Gen. Purp.</p> <p>8 Power supply 24 V AC/DC</p> <p>Measurement output</p> <p>0 Conductivity / resistance</p> <p>1 Conductivity / resistance and temperature</p> <p>3 PROFIBUS-PA</p> <p>4 PROFIBUS-DP</p> <p>5 Conductivity / resistance with HART®</p> <p>6 Conductivity / resistance, temperature and HART®</p> <p>Contacts</p> <p>05 No additional contacts</p> <p>10 2 contacts (limit values / PID / timer)</p> <p>15 4 contacts (limit values / PID / timer / Chemoclean)</p> <p>16 4 contacts (limit values / PID / timer)</p> <p>Additional equipment</p> <p>PRL Protective varnishing</p> <p>YYY Special version to customer requirements</p>	<div style="display: flex; align-items: center;"> <div style="margin-right: 10px;"> <p>↓</p><p>↓</p><p>↓</p><p>↓</p><p>↓</p> </div> <table border="1" style="border-collapse: collapse; text-align: center;"> <tr> <td style="width: 100px;">CLM223-</td> <td style="width: 20px;"> </td> <td style="width: 20px;"> </td> <td style="width: 20px;"> </td> <td style="width: 20px;"> </td> <td style="width: 20px;"> </td> <td style="width: 20px;"> </td> <td style="width: 20px;"> </td> </tr> <tr> <td>CLM253-</td> <td> </td> <td> </td> <td> </td> <td> </td> <td> </td> <td> </td> <td> </td> </tr> </table> </div> <p style="text-align: right; margin-top: 10px;">complete order code</p>	CLM223-								CLM253-							
CLM223-																	
CLM253-																	

Additional functions of the Plus package (CS and IS versions)

- Current output table, fields O23x
- Monitoring for sensor and process, function group P
- Cleaning (Chemoclean), fields R25x
- Automatic start of cleaning function Field F8
- Measurement according to USP 23 with prealarm, Fields R26x (only conductive with relay card)
- Concentration measurement, function group K
- Adaptive calibration, Fields C13x (only inductive)

2 Safety instructions

2.1 Intended application

Liquisys M CLM 223 / 253 is a field-tested and reliable transmitter to determine the conductivity and resistance of fluid media.

Liquisys M CLM 223 F / 253 F is particularly suitable for use in the following areas of application:

- Chemicals
- Pharmaceuticals
- Food industry
- Drinking water treatment
- Condensate treatment
- Municipal sewage treatment plants
- Water conditioning

2.2 General safety notes

This device has been manufactured for safe operation according to the state of the art in engineering and conforms to the applicable regulations and European standards (see Technical data). It has been designed according to EN 61010-1 and has left the manufacturer's works in perfect condition with regard to safety aspects.

However, if used improperly or for purposes other than the intended purpose, it may be dangerous, e.g. due to incorrect connection.



Warning:

- Operating this instrument in any way other than as described in these instructions may compromise the safety and function of the measuring system and is therefore impermissible.
- The notes and warnings in these installation and operating instructions must be strictly adhered to!

2.3 Installation, start-up, operation



Warning:

- This device may only be installed, connected electrically, commissioned, operated and serviced by properly trained personnel authorized by the system operator.
- The personnel must be familiar with these operating instructions and must adhere to the instructions described therein.
- Make sure that the power supply ratings match the data specified on the nameplate before you connect the instrument to a power source.
- A clearly identified mains disconnecting device must be installed close to the instrument.
- Live components can be touched through the vent slots in the housing and the openings on the rear of the housing. Do not insert any tools, wires or similar into these slots (only CLM 223).
- Check that all connections have been properly made before powering up the system!
- Damaged equipment that may be dangerous must not be operated and should be clearly identified as being defective.
- Measuring point faults may only be repaired by authorised and trained personnel.
- If faults cannot be remedied, the instrument must be removed from service and secured to prevent accidental start-up.
- Repairs not described in these operating instructions may only be performed at the manufacturer's works or by the Endress+Hauser Service Organization.

2.4 Monitoring and safety features

Safety features

The transmitter is protected against external influences and damage by the following design measures:

- Rugged housing
- Degree of protection provided by enclosure: IP 65 (CLM 253)
- UV resistance

Monitoring features

In the event of a system error or power failure, an alarm condition is signalled via a fault-signalling contact.

2.5 Immunity to interference

This instrument has been tested according to the applicable European standards for industrial applications with regard to electromagnetic compatibility. It is protected against electromagnetic interference by the following design measures:

- Cable screen
- Interference suppresser filter
- Interference suppression capacitors



Warning:

The specified immunity to interference only applies for devices connected as outlined in these operating instructions.

2.6 Declaration of conformity

The CLM 223/253 transmitter has been developed and manufactured in accordance with currently valid European standards and directives.

E+H certifies the compliance with the standards by using the **CE** sign.

3 Installation

The following procedure should be followed for a complete measuring system installation:

- Installation or attachment of transmitter (see chapter 3.3)
- Selection and connection of cables and sensor (see chapter 3.4, 3.5 and 9)
- Installation is followed by start-up (see chapter 5).

3.1 Measuring system

The complete measuring system comprises:

- The Liquisys M CLM 223 or CLM 253 transmitter
- A sensor with or without an integrated temperature sensor
- A measuring cable CYK 71 (conductive measurement) or measuring cable CLK 5 as fixed cable with sensor (inductive measurement).

Optional:

- Extension cable CYK 71 (conductive) or CLK 5 (inductive)
- Junction box VBM.

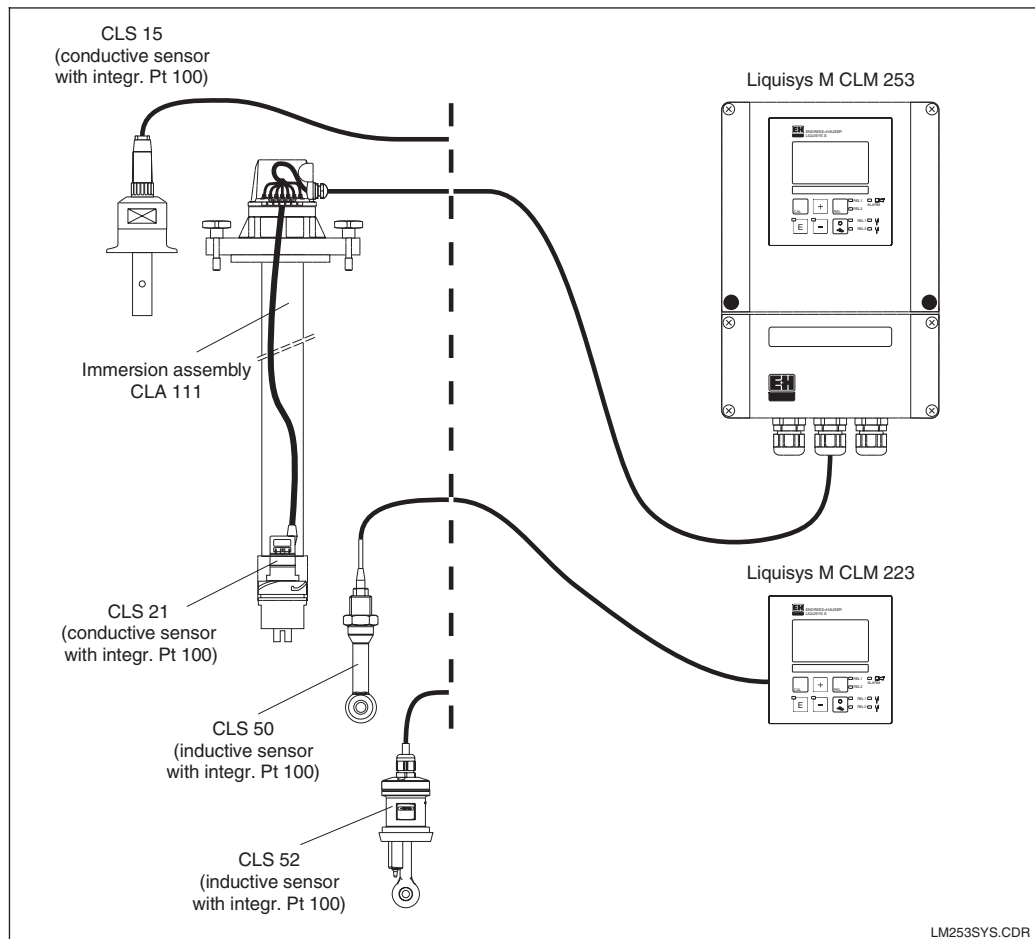

Complete measuring devices Liquisys M CLM 223 / 253 with measuring cable, assembly and conductivity sensor

Fig. 3.1

LM253SYS.CDR

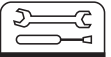

3.2 Dimensions

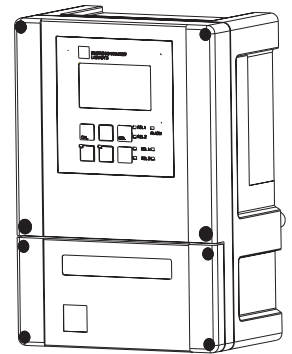
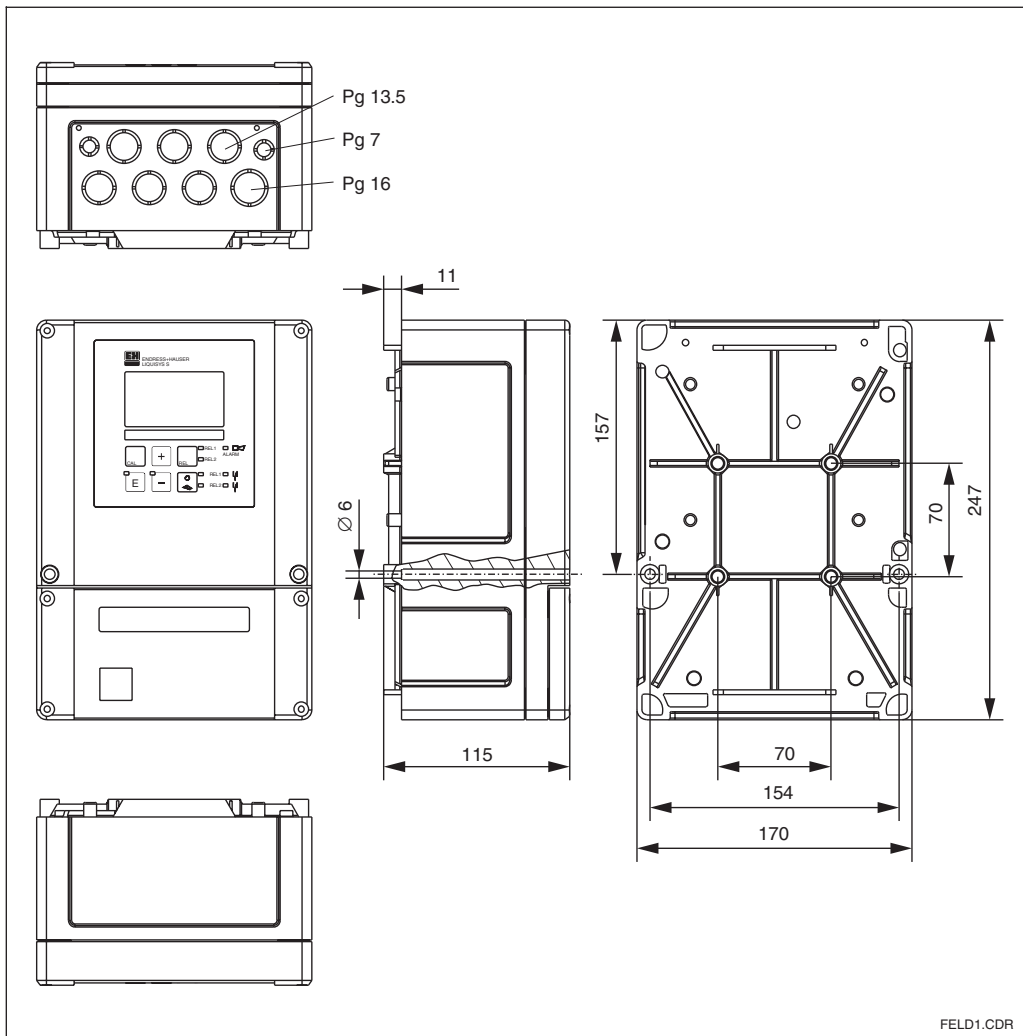
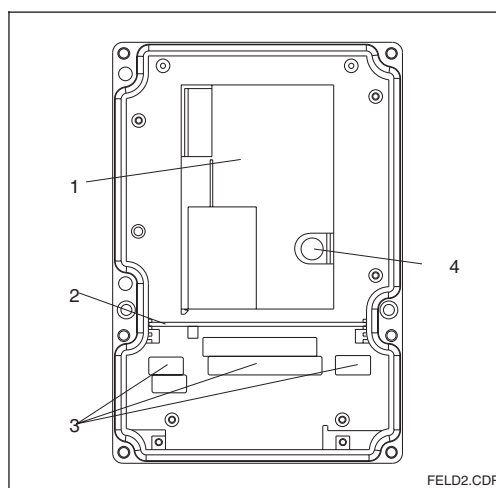

Fig. 3.2 Dimensions of Liquisys M CLM 253



Inside of housing of Liquisys M CLM 253
1 Removable electronics box
2 Partition plate
3 Terminal blocks
4 Fuse

Fig. 3.3

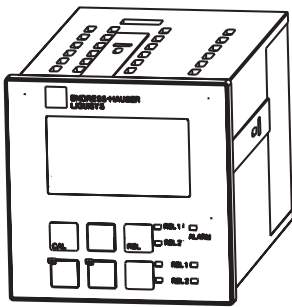
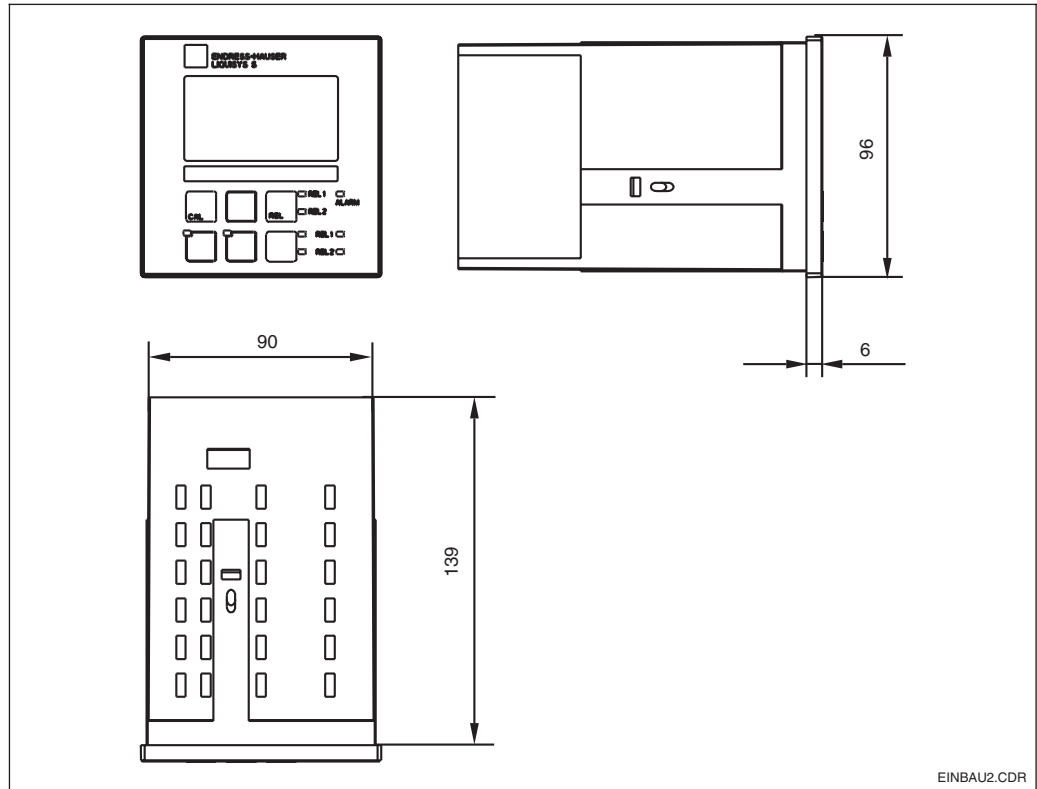

Fig. 3.4 Liquisys M CLM 223, panel-mounted version



EINBAU2.CDR

3.3 Mounting

3.3.1 Field instrument

Several mounting versions are available for the Liquisys M in the field instrument version:

- Post mounting on cylindrical pipes
- Post mounting on a square post
- Wall mounting using fastening screws.

Weather protection cover CYY 101 can be used for outdoor installation in conjunction with all mounting versions.



Note:

If installed outdoors, weather protection cover required.

Weather protection cover CYY 101

Weather protection cover for outdoor installation, to be mounted on field instrument; material: stainless steel SS 304; order no.: CYY 101-A

For post or pipe installation, the post mounting kit is additionally required.

Fig. 3.5 Weather protection cover for field instruments

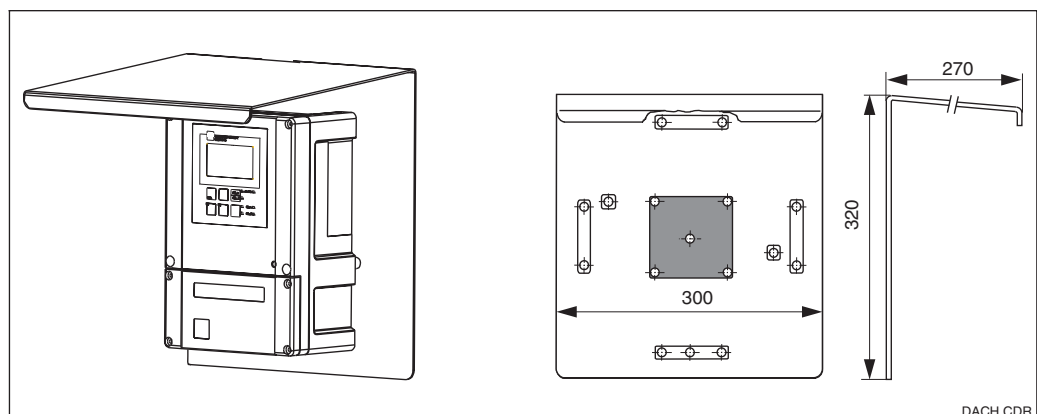

DACH.CDR

Post mounting kit

Mounting kit for installation of field housing on horizontal and vertical pipes (max. \varnothing 60 mm); also aids mounting of weather protection cover.

Material: stainless steel SS 304
Order no.: 50086842

Universal mounting post CYY 102

Square tube for mounting of measuring transmitters;

Material: stainless steel SS 304
Order no.: CYY 102-A

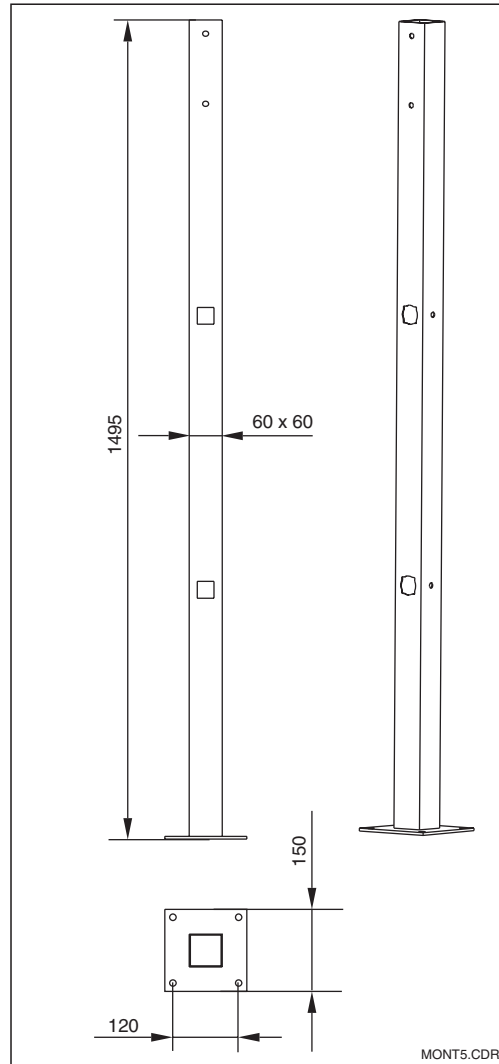
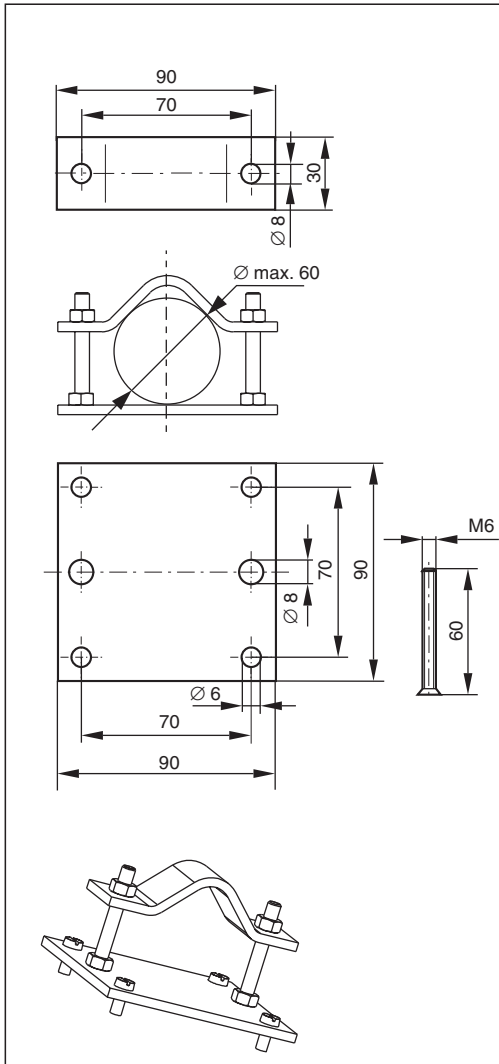

left:
Mounting kit
for post mounting on
cylindrical pipes

right:
Square mounting post

Fig. 3.6

3.3.2 Mounting examples

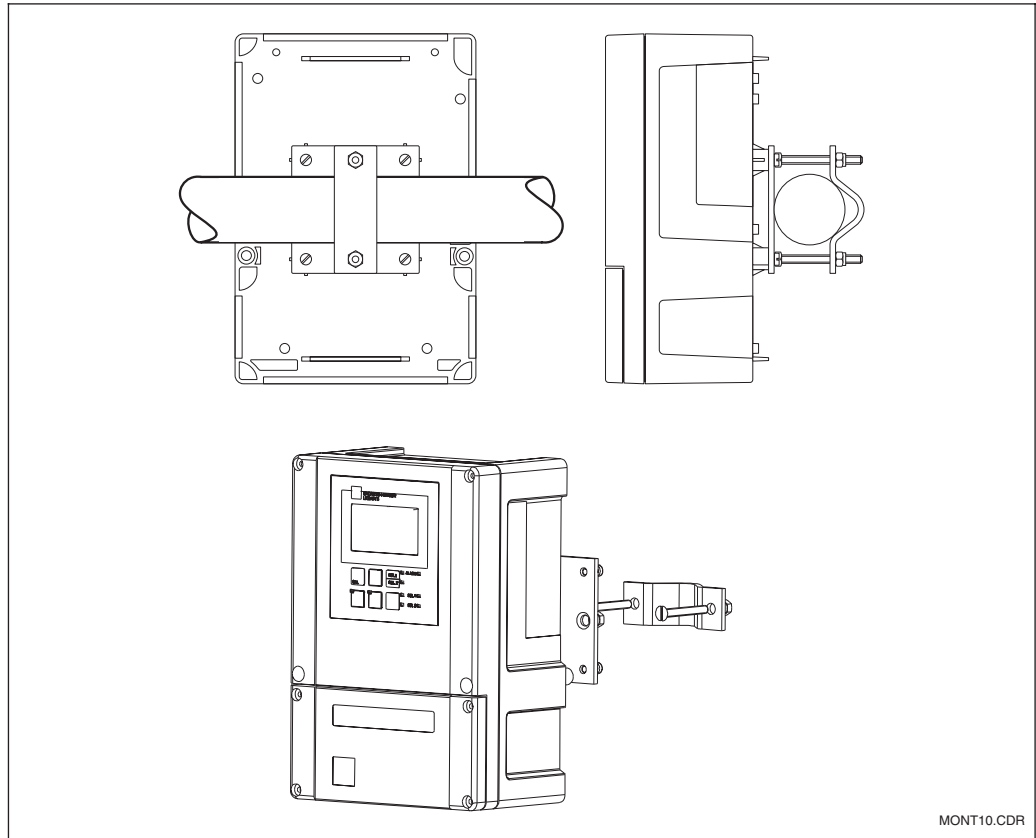

Fig. 3.7
Liquisys M, field instrument:
Pipe mounting

MONT10.CDR

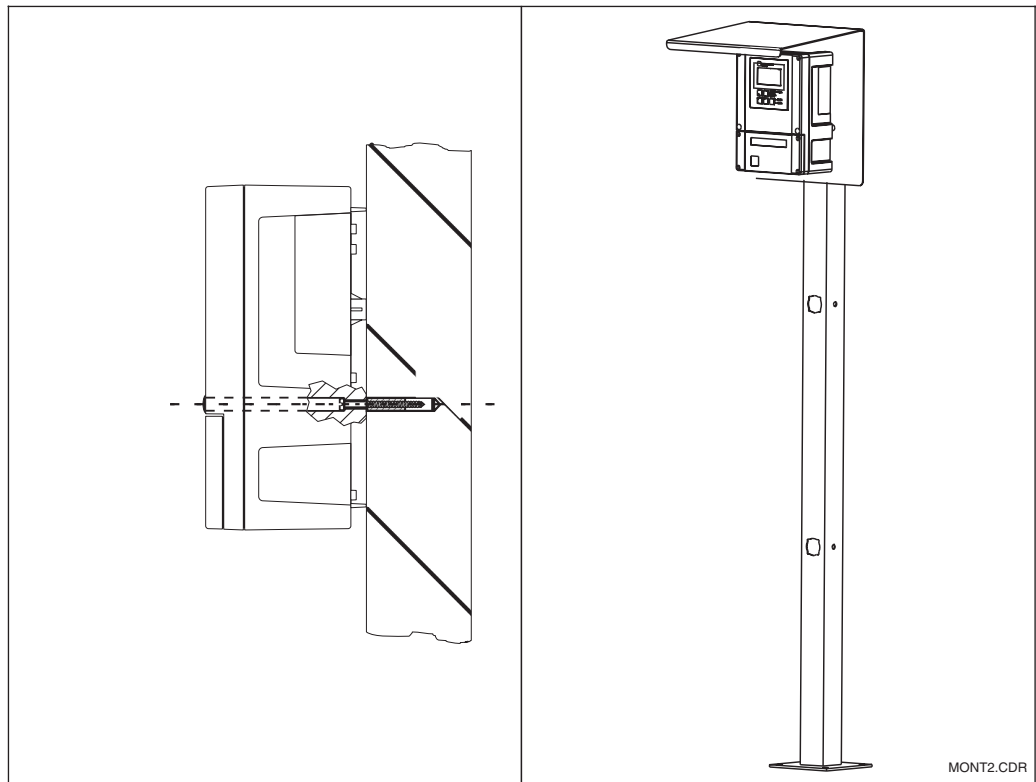

Fig. 3.8
Liquisys M,
field instrument

left:
Wall mounting

right:
Mounting with universal
post and weather
protection cover

MONT2.CDR

3.3.3 Panel-mounted instrument

The instrument is attached using the supplied tensioning screws (see Fig. 3.9).
The required overall installation depth is approx. 165 mm.

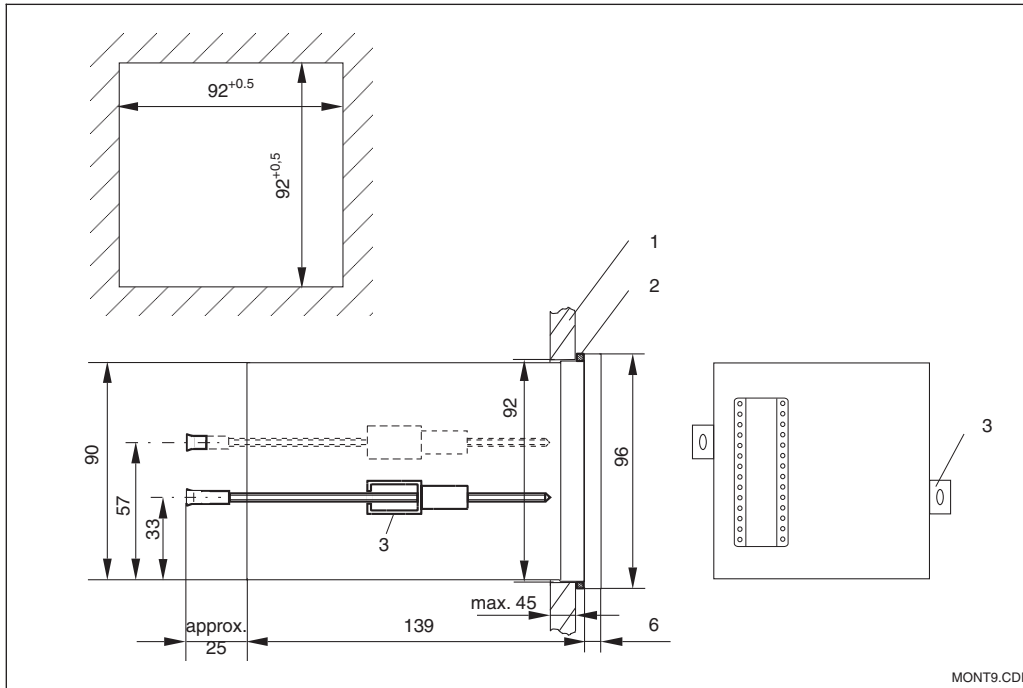

Attachment of panel-mounted instrument
 1 Wall of control cabinet
 2 Gasket
 3 Tensioning screws

3.4 Electrical connection

Connection diagram

The connection diagram depicted in Fig. 3.10 shows the connections for an inductive or a conductive sensor (dashed lines). The connection for the various sensors is shown in more detail in the figures 3.13 to 3.15

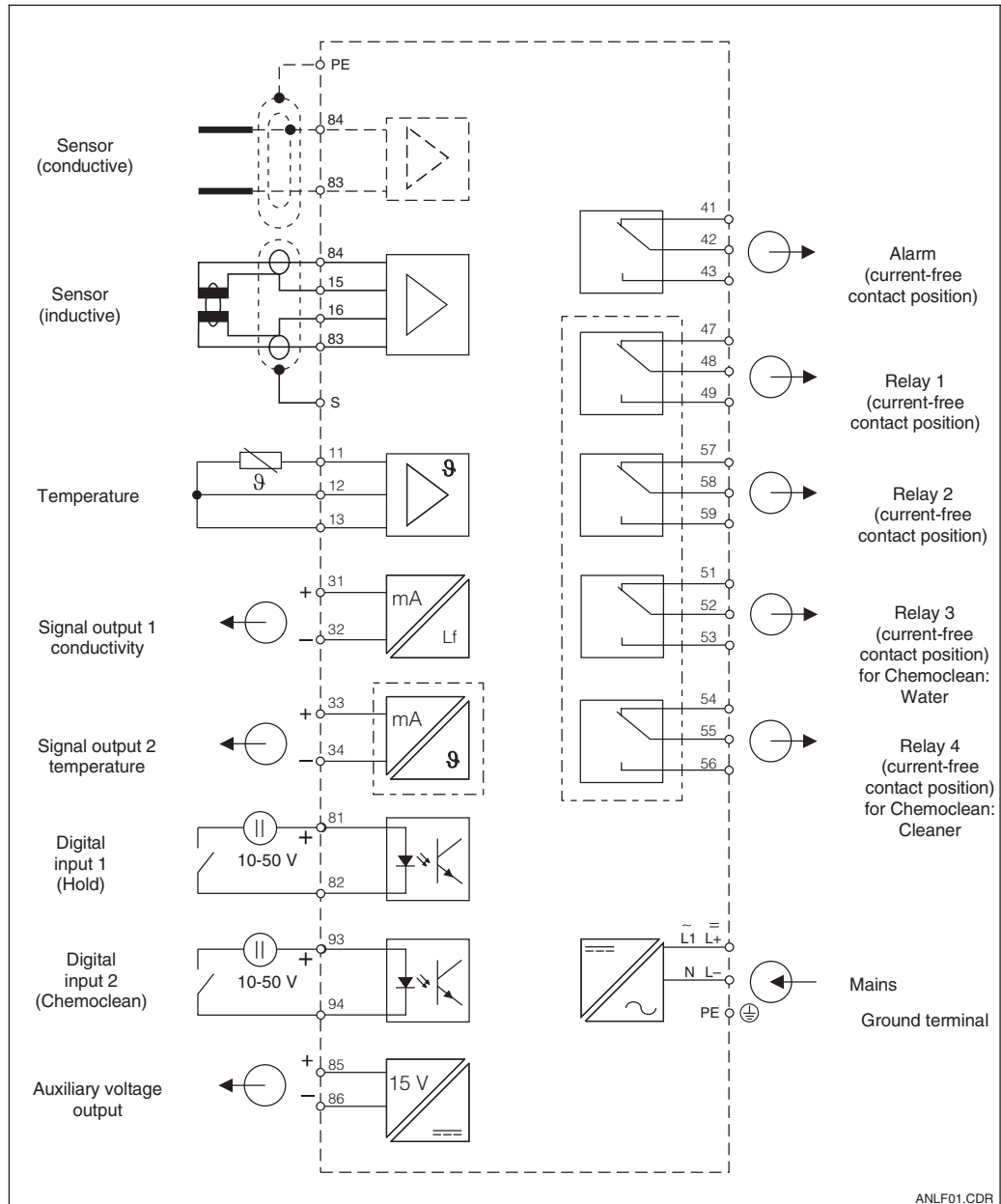

Fig. 3.10 Electrical connection of Liquisys M CLM 223 / 253 with full connection

ANLF01.CDR



Note:

- The instrument has protection class II and is generally operated without protective earth connection.
- However you require a ground connection to ground the measuring cable screening.
- Mains supply voltage fluctuations should not exceed ten percent of the nominal supply voltage.
- 24V AC/DC models must be supplied from an energy limiting SELV source in accordance with dir. IEC 1010.1 Annex H.

Connections of field instrument

For connection, the measuring cables are introduced through the cable glands on the field instrument and connected according to the connection diagram in figures 3.10 and 3.11.



Note:

- Please label the sensor terminal block with the enclosed sticker.
- Connect the ground terminal with PE.



Caution!

- Terminal designated as NC may not be switched.
- Undesignated terminals may not be switched.

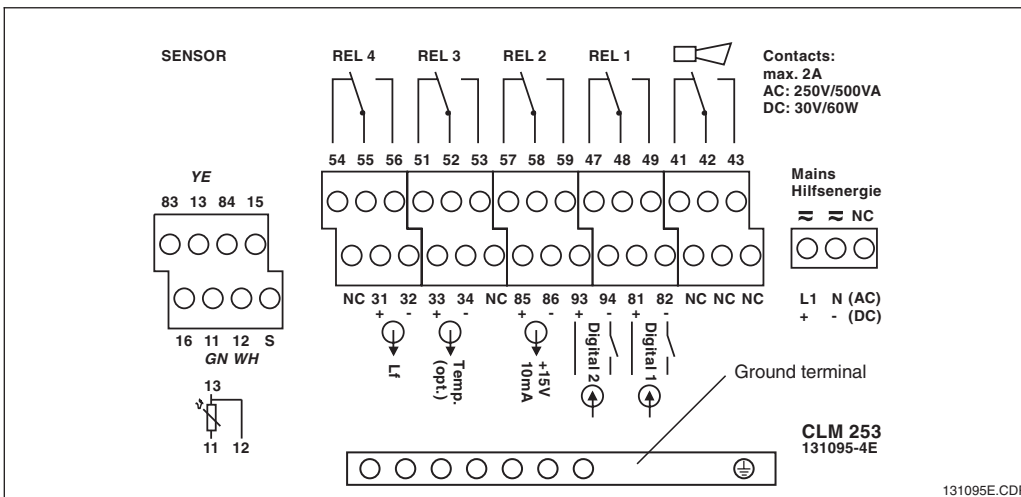

Fig. 3.11 Connection compartment sticker for field instrument CLM 253

Connections of panel-mounted instrument

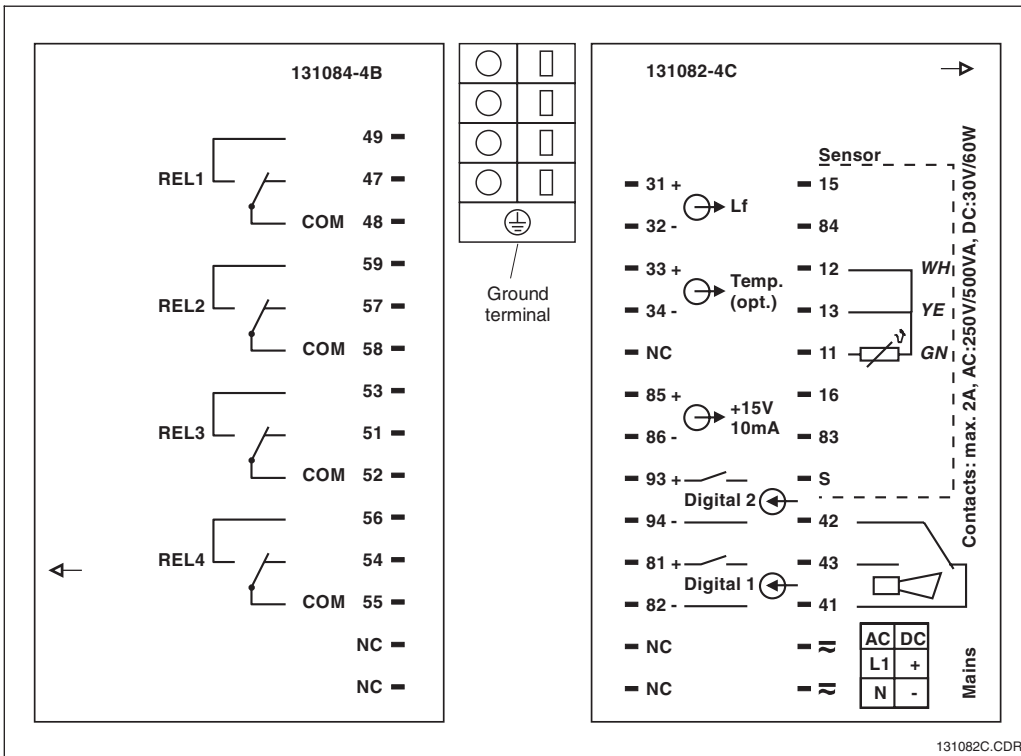

Fig. 3.12 Connection compartment sticker for panel-mounted instrument CLM 223

3.5 Sensor installation and cable connection

Measuring cable connection

The terminal block is located in a separate connection compartment which is accessible by opening the plastic cover. Remove the pre-pressed knock-outs for cable entry.

The conductivity sensors are connected using a special, shielded multi-core cable. Termination instructions are supplied with the measuring cables. Use junction box VBM to extend the measuring cable.



Note:

- Protect connectors, cable ends and terminals against moisture to prevent inaccurate measurement!
- For further information on cables and junction boxes refer to chap. 9 Accessories.

Measuring cable requirements		
Sensor type	Cable	Extension
2-electrode sensors with or without temperature sensor Pt 100	CYK 71	Junction box VBM + CYK 71
Inductive sensors CLS 50, CLS 52	Cable permanently attached to sensor	Junction box VBM + CLK 5
Maximum cable length		
Conductive conductivity measurement	max. 100 m with CYK 71 (corresponds to 10 nF)	
Resistance measurement	max. 15 m with CYK 71 (corresponds to 2 nF)	
Inductive conductivity measurement	max. 55 m (with CLK 5 and sensor cable)	

Structure and termination of measuring cables

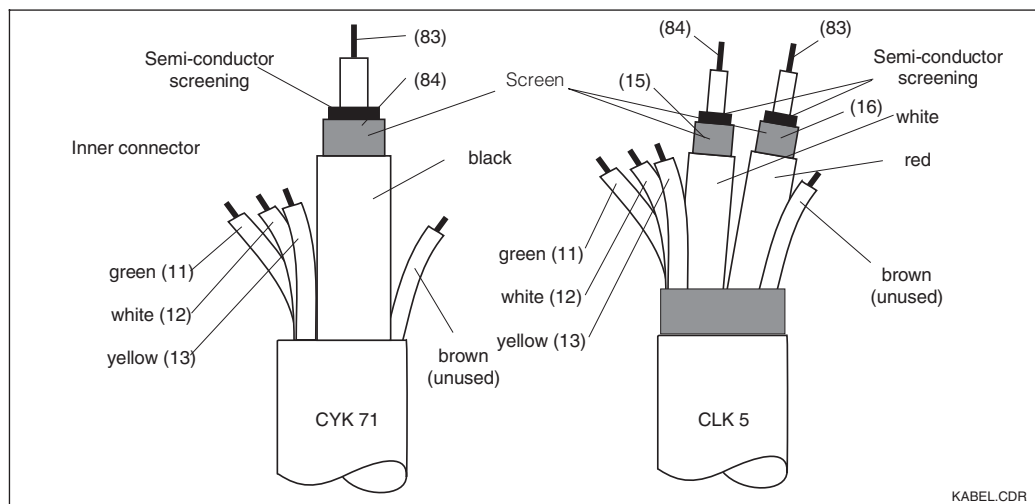

Structure of special measuring cables CYK 71 (left) and CLK 5 (right)
Fig. 3.13

Examples for connection



Note:

- Ground the sensor screen in order to ensure functional safety and measuring stability of the measuring system. For that purpose, a PE ground terminal is available. This is located on the cover frame of the panel-mounted instrument CLM 223, or in the connection compartment of the field instrument CLM 253.
- Ground the PE ground terminal.

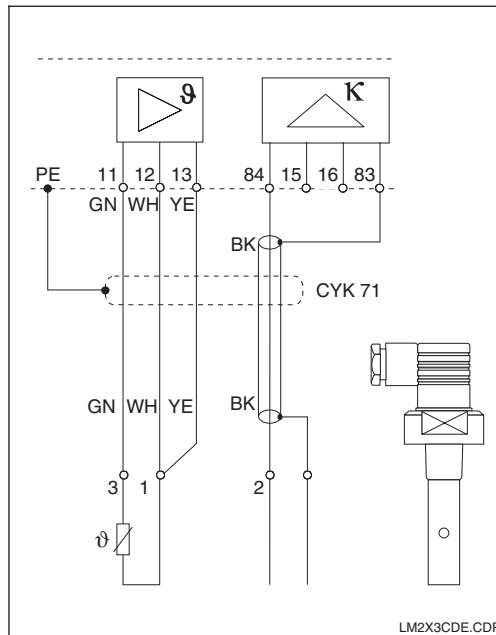

Connection of conductive sensors (CLS 15, CLS 19, CLS 20, CLS 21, CLS 30)

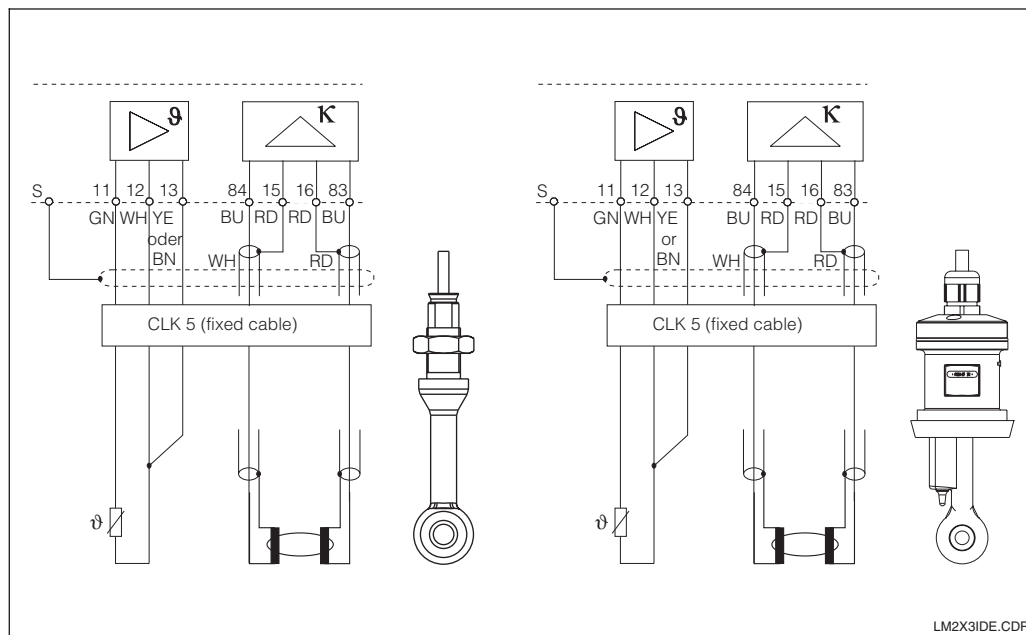

Connection of conductive sensors (left: CLS 50, right: CLS 52)

4 Operation

4.1 Operator interface

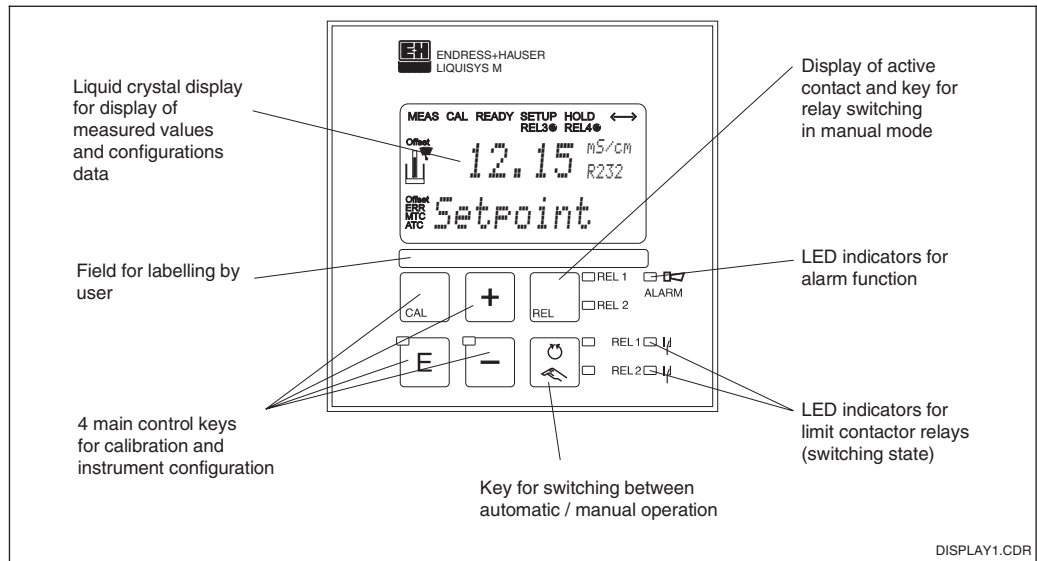

4.2 Display

LED indicators



Indication of current operating mode "Auto" (green LED) or "Manual" (yellow LED)



Indication for relay controlled in "Manual" mode (red LED)



Indicates the state of relays 1 and 2

LED green: Measured value within permissible limits, relay inactive
LED red: Measured value outside permissible limits, relay active





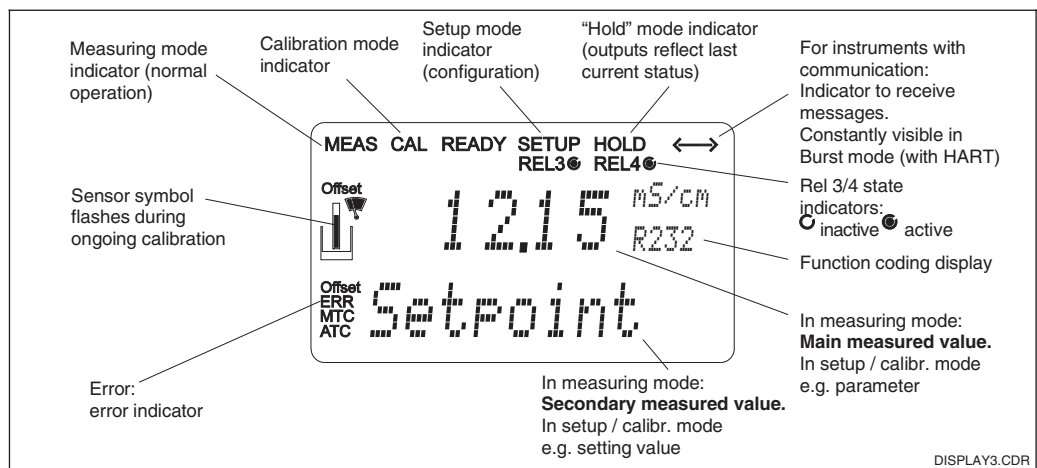

Alarm indication e.g. for continuous limit violation, temperature sensor failure or system errors (see error list chapter 7)

Liquid crystal display

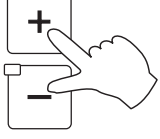
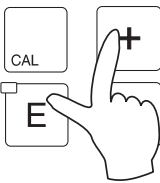
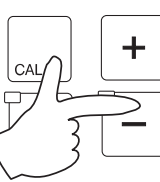

4.3 Key functions

	<p>CAL key When the CAL key is pressed, the instrument prompts for the calibration access code (fixed setting: 22 for calibration; any setting for calibration data checking). Acknowledge with the CAL key to proceed. Calibration uses the calibration data set in function group C.</p>
	<p>ENTER key The ENTER key has the following functions: <ul style="list-style-type: none"> • Opens the Setup menu in measuring mode • Stores (acknowledges) data entered in Setup mode. • Moving on within the function groups. </p>
	<p>PLUS key and MINUS key The PLUS and MINUS keys have the following functions: <ul style="list-style-type: none"> • Selection of function groups • Setting of parameters and numeric values • Relay operation in manual mode (see chapter 4.4). <p>Pressing the PLUS key allows you to switch between the current input in % and mA.</p> <p>Repeatedly pressing the PLUS key displays the following settings in sequence as secondary measured values: <ol style="list-style-type: none"> 1. Temperature display in °F 2. Hide temperature display 3. Measured value display of uncompensated conductivity 4. Back to basic setting </p> <p>Repeatedly pressing the MINUS key outputs errors: <ol style="list-style-type: none"> 1. The current errors are displayed one after the other (max. 10) 2. After all the errors are displayed, the standard display is unhidden. In function group F, you can define an alarm for each error code separately.</p> </p>
	<p>REL key The REL key is used in manual mode to switch between the relays and the manual start cleaning function.</p>
	<p>AUTO key The AUTO key is used to toggle between the automatic and manual modes of operation.</p>
	<p>Escape function Press the PLUS and MINUS keys simultaneously to return to the main menu. Press the PLUS and MINUS keys again to return to measuring mode.</p>
	<p>Locking the keypad Pressing the PLUS and ENTER keys simultaneously locks the keypad. The code prompt displays the code 9999.</p>
	<p>Unlocking the keypad Pressing the CAL and MINUS keys simultaneously unlocks the keypad. The code prompt displays the code 0.</p>

4.4 Auto / manual mode of operation

	<p>Auto mode In this mode of operation, the relays are controlled by the transmitter.</p>
	<p>REL key The REL key is used to select one of the relays present in the instrument.</p>
 	<p>Switching to manual mode The instrument is switched to the manual mode for relay setting by pressing the following keys:</p> <p>Press AUTO key.</p> <p>Enter code 22.</p> <p>Select relay or function. Press the REL key to toggle between the relays. The display shows the selected relay in the second line.</p> <p>Set the relays. Switch on with PLUS, switch off with MINUS. The relay remains in effects until it is actively reset.</p> <p>Press AUTO key for returning to the measuring mode.</p>



Note:

- Enable the manual mode by entering access code "22".
- The operating mode remains in effect even after a power failure.
- The manual mode takes precedence over any other automatic function (hold).
- Hardware locking in the manual mode is not possible.
- The manual settings remain in effect until they are actively reset.
- Error code E102 is signalled in the manual mode.

4.5 Operating concept

4.5.1 Operating modes

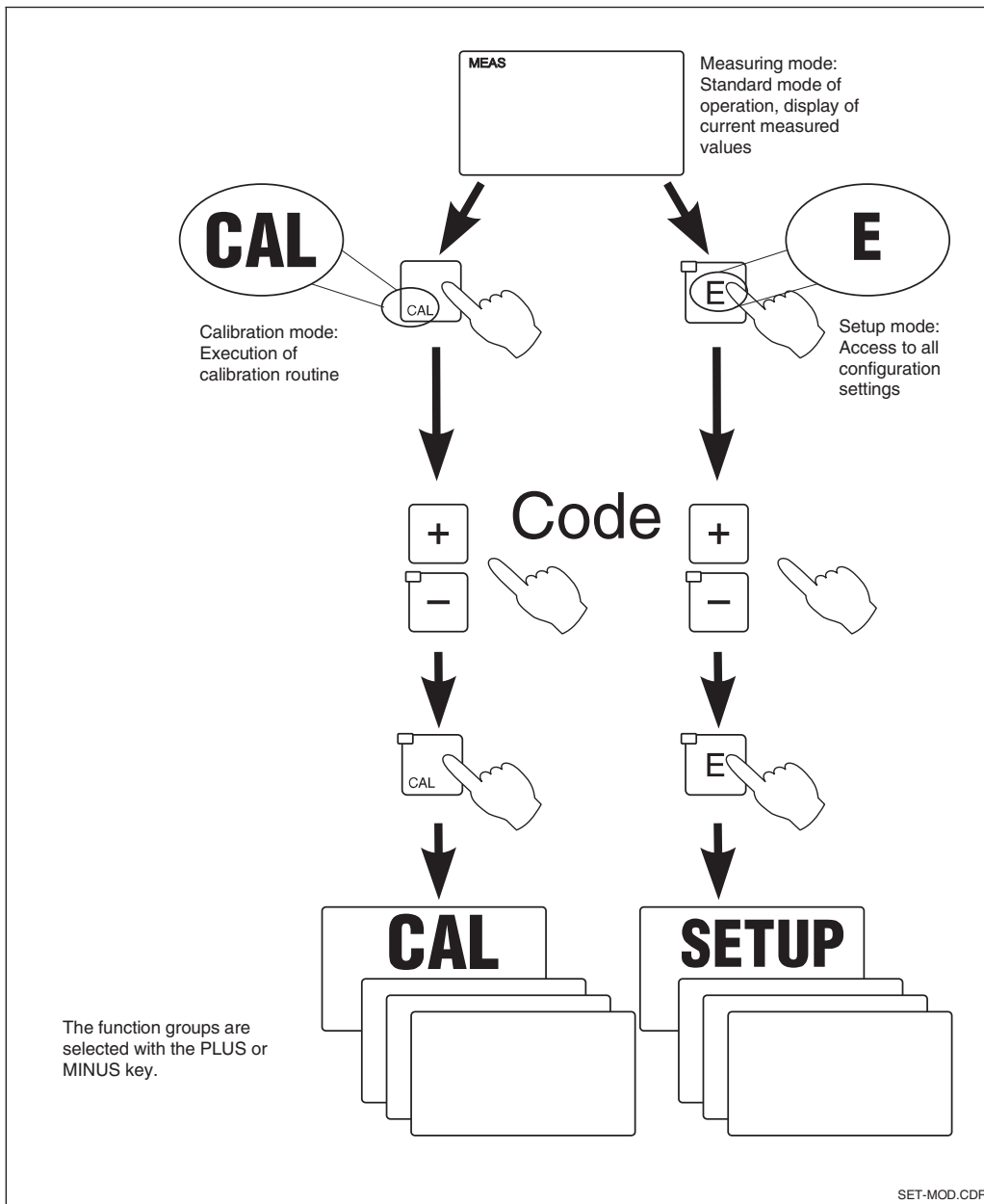

Fig. 4.3 Description of possible operating modes



Note:

- Remains in Setup mode for approx. 15 mins., the system automatically jumps back to Measuring mode. An active Hold function (Hold at Setup) is then reset.

4.5.2 Access codes

All instrument access codes are fixed, i.e. they cannot be modified. When the instrument requests the access codes, it recognises the difference between codes (cf. Fig. 5.3):

- **CAL key + Code 22:** Access to Calibration and Offset menus.
- **ENTER key + Code 22:** Access to the Configuration menus, allowing configuration and user-specific settings.
- **PLUS/ENTER keys + Code 9999:** Locks the keypad.
- **CAL/MINUS keys + Code 0:** Unlocks the keypad.
- **CAL or ENTER key + any Code:** access to Read mode, i.e. all settings can be read but not changed.

4.5.3 Menu structure

The configuration and calibration functions are arranged in a menu structure by function groups.

The function groups are selected in the setup mode with the PLUS and MINUS keys. The ENTER key is used to move from one function to the next within a function group. The PLUS and MINUS keys are used for option selection and editing. Selections must be confirmed by pressing the ENTER key. This also moves the cursor to the next function.

Pressing the PLUS and MINUS keys at the same time terminates programming (return to main menu).



Note:

- If a change is made but not confirmed by pressing the ENTER key, the previous setting is retained.
- See the appendix of these operating instructions for an overview of the Liquisys M menu structure.

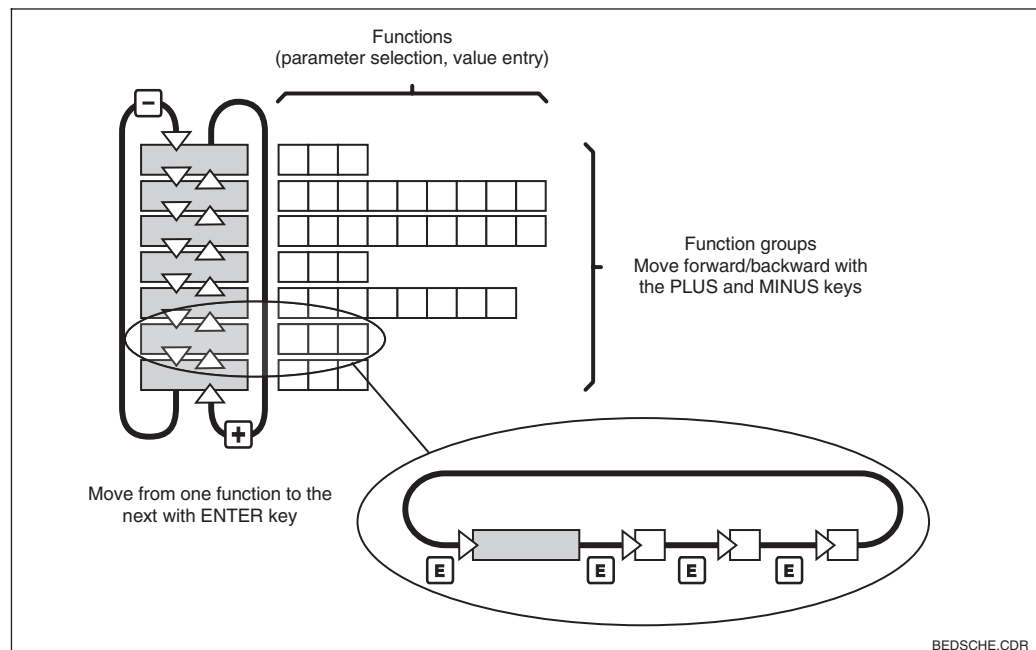

Fig. 4.4 Schematic representation of Liquisys M menu structure

4.5.4 Hold function: “Freezes” the outputs

The current output is “frozen” in the setup mode and during calibration, i.e. the last current value is constantly output. HOLD appears on the display.

**Note:**

- Hold settings can be found in chapter 5.6, function S2.
- During hold, all contacts will go to their normal positions.
- An active hold has priority over all other automatic functions.
- With every hold, the I component of the controller is set to zero.
- A possibly accumulated alarm delay is reset to “0”.
- The hold function can also be activated externally via the hold input (see wiring diagram Fig. 3.10; digital input 1).
- The manual hold (field S3) remains active even after a power failure.

5 Instrument configuration

After power-up the instrument performs a self-test and then enters to measuring mode.

Now it can be configured and calibrated for the first time. The values set by the user are kept even in the event of a power failure.

The following function groups are available on the Liquisys M (the groups that are only available in the Plus package are marked accordingly in the function descriptions):

Setup mode

- SETUP 1 (A) see chap. 5.2.1
- SETUP 2 (B) see chap. 5.2.2
- CURRENT OUTPUT (O) see chap. 5.3
- ALARM (F) see chap. 5.4.1
- CHECK (P) see chap. 5.4.2
- RELAY (R) see chap. 5.5
- ALPHA TABLE (T) see chap. 5.6
- CONCENTRATION (K) see chap. 5.7
- SERVICE (S) see chap. 5.8
- E+H SERVICE (E) see chap. 5.9
- INTERFACE (I) see chap. 5.10

Calibration mode

- CALIBRATION (C) see chap. 5.11

Fig. 5.1 Example of display in setup mode

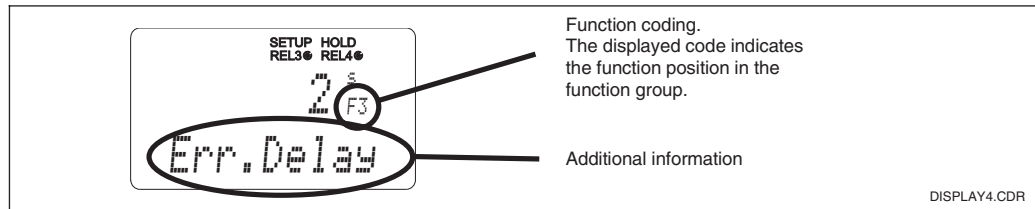
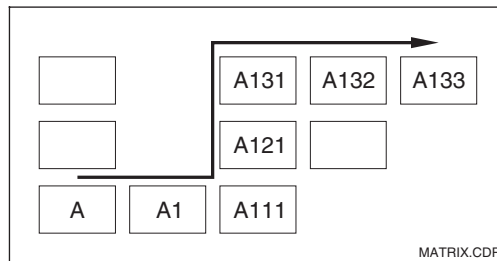

Fig. 5.2 Function coding



Selecting and locating functions is facilitated by a code displayed for each function in a special display field. The structure of this coding is given in Fig. 5.2. The first column indicates the function group as a letter (see group designations). The functions in the individual groups are counted from the top to the bottom and from the left to the right.

Factory settings

When the instrument is switched on for the first time, the factory settings are in effect. The following table provides an overview of all major settings.

Please refer to the description of the individual function groups in chapter 5 for all other factory settings (the factory settings are printed in **bold**).

Function	Factory setting
Type of measurement	Conductive conductivity, Temperature in °C
Temperature compensation type	Linear with reference temperature 25 °C
Temperature compensation	Automatic (ATC on)
Limit for controller 1	9999 mS/cm
Limit for controller 2	9999 mS/cm
Hold	Active during configuration and calibration

Measuring range	0 μ S/cm ... 2 S/cm (no measuring ranges for setting). The setting is flowing and is guided by the connected sensors (see chapter 9).
Current outputs 1 and 2*	4 ... 20 mA
Current output 1: meas. value for 4 mA signal current	0.00 S/cm
Current output 1: meas. value for 20 mA signal current	2000 mS/cm
Current output 2*: temperature value for 4 mA signal current	35.0 $^{\circ}$ C
Current output 2*: temperature value at 20 mA signal current	250.0 $^{\circ}$ C

*on versions equipped accordingly

Alarm contact

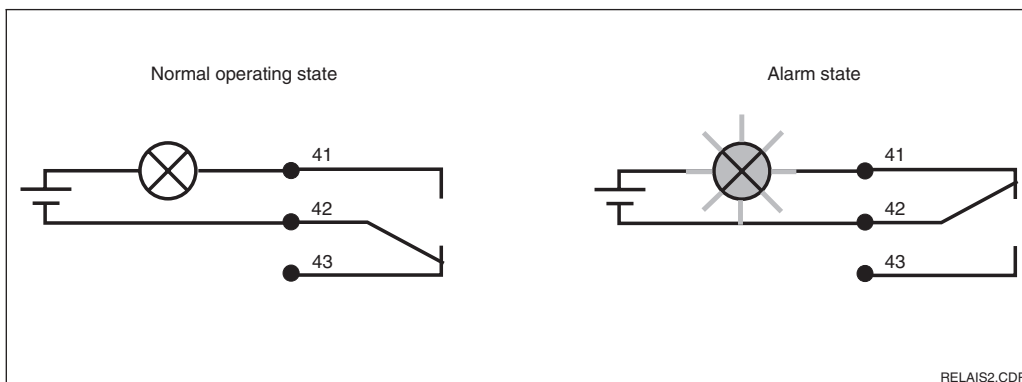

Recommended fail-safe circuit for an alarm contact

Fig. 5.3

Normal operating state:

- Instrument in operation
- No error message available (Alarm LED green)

→ Relay picked up
→ Contact 42/43 closed

Alarm state:

- Error message available (Alarm LED red) or
- Instrument defective or voltage-free (Alarm LED off)

→ Relay dropped out
→ Contact 41/42 closed

5.1 Start-up

After power-up (connection to power supply established), the user must make the following selections in the specified function groups:

- **Function group SERVICE (S)**
S1: Select language and exit function group (not required for English).
 - **Function group SETUP 1 (A)**
Adjust all the parameter in this group, see chapter 5.2.1.
 - **Function group SETUP 2 (B)**
Adjust all the parameters in this group, see chapter 5.2.2.
- Other configuration options are explained in the chapters to follow for each menu.

5.2 System configuration

The system is configured using the function groups SETUP 1 and SETUP 2. The measurement type and sensor are selected here, and the settings for temperature measurement are made. All the parameters in these two function groups are to be configured to avoid measuring errors or failure to measure at all.

5.2.1 Setup 1

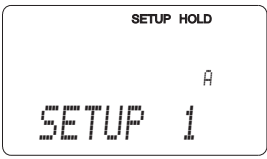
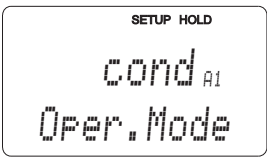
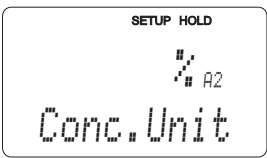
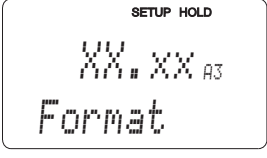
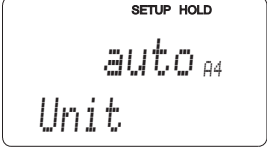
Coding	Field	Selection or range Factory setting	Display	Info
A	Function group SETUP 1			Initial display in function group SETUP 1.
A1	Operation mode selection	cond = conductive ind = inductive MΩm = resistance Conc = <i>concentration</i>		Display varies according to instrument version: – cond/resistance/conc – ind/conc. If the operating mode changes, the user settings are reset to the basic settings.
A2	Selection of concentration unit to be displayed (only with Plus package)	% <i>ppm</i> <i>mg/l</i> <i>TDS</i> <i>without</i>		A2 only active, if A1 = conc.
A3	Selection of display format for concentration unit (only with Plus package)	XX.xx <i>X.xxx</i> <i>XXX.x</i> <i>XXXX</i>		A3 only active, if A1 = conc.
A4	Selection of unit to be displayed	auto , μS/cm, mS/cm, S/cm, μS/m, mS/m, S/m, auto Ω, kΩ·cm, MΩ·cm, kΩ·m		When “auto” or “auto Ω” is selected, the maximum resolution possible is automatically selected. A4 not active, if A1 = Conc.

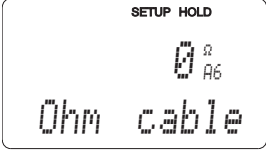
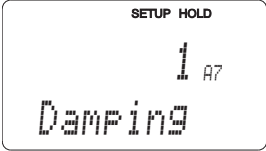

Factory settings are printed in **bold** face;
base version does not include functions in *italic*.

Coding	Field	Selection or range Factory setting	Display	Info
A5	Enter cell constant for sensors connected	cond: 1,000 cm⁻¹ ind: 1.98 cm⁻¹ MOhm: 0.01 cm⁻¹ 0.0025 ... 99.99 cm ⁻¹		Refer to the sensor quality certificate for the exact cell constant.
A6	Enter cable resistance	0 Ω 0 ... 99.99 Ω		Only if A1 = cond. Data on CYK 71 in chapter 10. Multiply the standardised line resistance by the actual cable length.
A7	Enter measured value damping	1 1 ... 60		Measured value damping causes averaging over the specified number of individual measured values. It is used, for example, to stabilise the display with applications that fluctuate a great deal. There is no damping if "1" is entered.

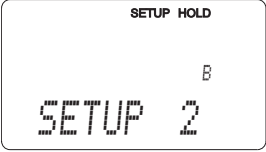
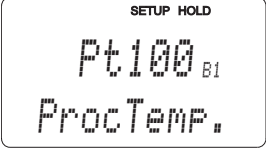
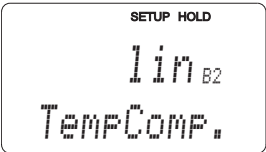
5.2.2 Setup 2

Coding	Field	Selection or range Factory setting	Display	Info
B	Function group SETUP 2			Initial display in function group SETUP 2.
B1	Selection of temperature sensor	Pt100 Pt1k = Pt 1000 NTC30 fixed		"Fixed": No temperature measurement if fixed temperature value is specified.
B2	Selection of temperature compensation type	lin = linear <i>Tab</i> = table NaCl = common salt (IEC 746) Pure = ultrapure water none		This choice does not appear for concentration measurement. "Pure" is only available for conductive devices.

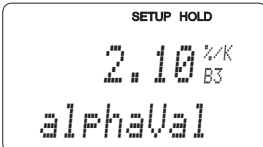
Factory settings are printed in **bold** face;
base version does not include functions in *italic*.

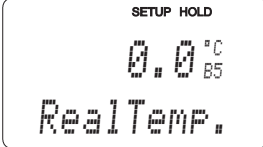
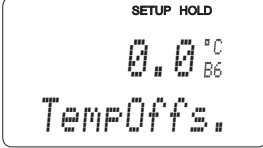
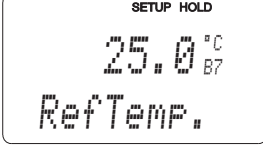
Coding	Field	Selection or range Factory setting	Display	Info
B3	Enter temperature coefficient α	2.10 %/K 0.00 ... 20.00 %/K		Only with B2 = lin. With other settings in B2, Field B3 has no influence.
B4	Enter correct process temperature	25.0 °C -35.0 ... 250.0 °C		Only for B1 = fixed. You can only edit the correction of the measured temperature value in °C.
B5	Configure temperature sensor	Actual value display -35.0 ... 250.0 °C		Making this entry allows the temperature sensor to be configured with an external measurement. Omitted if B1 = fixed.
B6	Enter temperature difference (offset)	Current offset -5.0 ... 5.0 °C		The offset is the difference between measured and entered temperature. Omitted if B1 = fixed.
B7	Enter reference temperature	25.0 °C -35 ... +250.0 °C		

5.3 Current outputs

The function group CURRENT OUTPUT is used to configure the individual outputs. Either a linear (O2 (1)) or, in conjunction with the Plus package, a user-defined current output characteristic (O2 (3)) can be entered. Furthermore, a current output value can be simulated to check the current outputs (O2 (2)).

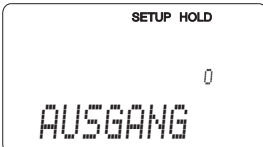
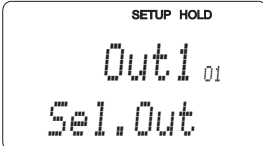
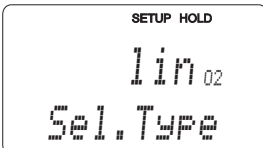
Coding	Field	Selection or range Factory setting	Display	Info
O	Function group CURRENT OUTPUT			Initial display in function group CURRENT OUTPUT.
O1	Select current output	Out1 <i>Out2</i>		A different characteristic can be selected for each output.
O2 (1)	Enter linear characteristic	lin = linear (1) <i>sim = simulation (2)</i> <i>Tab = table (3)</i>		The slope of the characteristic may be positive or negative. See O2 (2), O2 (3) for the simulation and table characteristics.

Factory settings are printed in **bold** face;
base version does not include functions in *italic*.

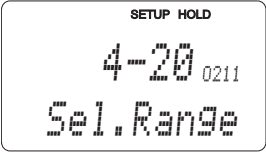
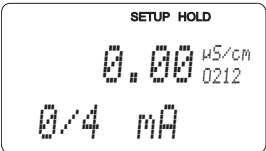
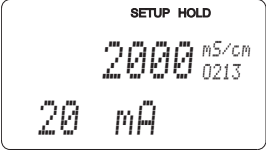
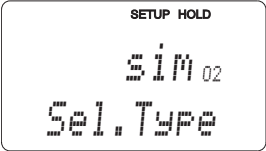
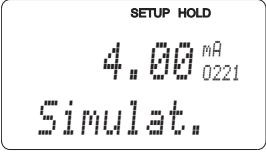
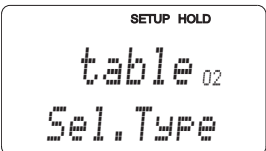
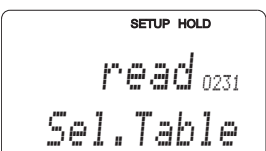
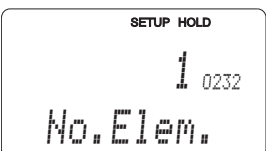
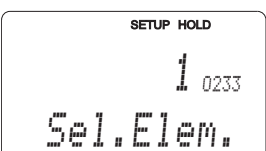
Coding	Field	Selection or range Factory setting	Display	Info
	O211	Selection of current range 4–20 mA 0–20 mA		
	O212	0/4 mA value; enter correspond- ing measured value cond/ind: 0.00 µS/cm MOhm: 0.00 kΩ·cm Conc: 0.00 % Temp.: 0.0 °C entire measuring range		Enter the measured value corresponding to the minimum current value (0/4 mA) at the transmitter output. Display format from A3. (Spreading see Technical data.)
	O213	20 mA value; enter correspond- ing measured value cond/ind: 2000 mS/cm MOhm: 500 kΩ·cm Conc: 99.99 % Temp.: 150.0 °C entire measuring range		Enter the measured value corresponding to the maximum current value (20 mA) at the transmitter output. Display format from A3. (Spreading see Technical data.)
	O2 (2)	Current output simulation lin = linear (1) sim = simulation (2) Tab = Table (3)		This simulation is terminated by selecting (1) or (3). See O2 (1), O2 (3) for other characteristics.
	O221	Enter simulation value current value 0.00 ... 22.00 mA		The current value entered here is output through the current output.
	O2 (3)	Enter current output table (only with Plus package) lin = linear (1) sim = simulation (2) Tab = Table (3)		Values may also be added or changed at a later point in time. The values entered are automatically sorted in ascending order by current value. See O2 (1), O2 (2) for other characteristics.
	O231	Selection of table option read edit		
	O232	Enter number of table value pairs 1 1 ... 10		This is where the number of x and y value pairs (measured value and associated current value) is entered.
	O233	Selection of table value pair 1 1 ... Number of table value pairs Finished		The function chain O233 ... O235 will run though as many times as correspond to the value in O232. "Finished" appears as the last step. After confirmation the system jumps to O236.

Factory settings are printed in **bold** face;
base version does not include functions in *italic*.

Coding		Field	Selection or range Factory setting	Display	Info
	O234	Enter x value (measured value)	cond/ind: 0.00 $\mu\text{S/cm}$ MOhm: 0.00 $\text{k}\Omega\text{-cm}$ Conc: 0.00 % Temp.: 0.0 $^{\circ}\text{C}$ entire measuring range		x value = User-specified measured value.
	O235	Enter y value (current value)	4.00 mA 0.00 ... 20.00 mA		y value = Current value belonging to O234 which is specified by user.
	O236	Enter whether or not the table status is OK	yes no		Return to O2. If no, then set table correctly (all previous settings are kept) or back to measurement mode (this makes the table invalid).

5.4 Monitoring functions

The monitoring functions are used to define various alarms and to set output contacts. Each individual error can be defined to be effective or not (at the contact or as an error current). Moreover, sensor polarisation can be detected (P1). An alarm condition can be defined to activate a cleaning function (F8).

5.4.1 Alarm

Coding		Field	Selection or range Factory setting	Display	Info
F		Function group ALARM			Alarm function settings.
	F1	Selection of contact type	Stead = steady contact Fleet = fleeting contact		The contact type selected here only applies to the alarm contact.
	F2	Selection of time unit	s min		

Factory settings are printed in **bold** face;
Factory settings are printed in **bold** face;
base version does not include functions in *italics*.

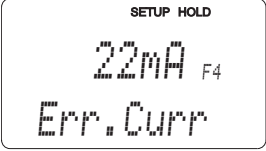
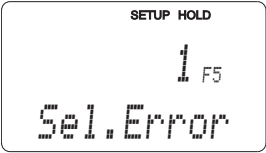
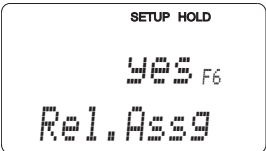
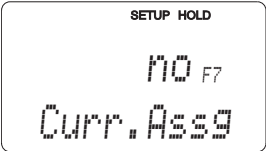
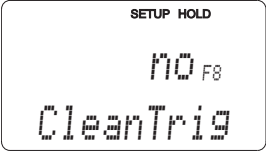
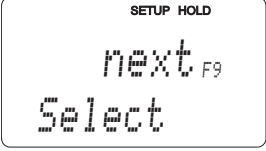
Coding	Field	Selection or range Factory setting	Display	Info
F3	Enter alarm delay	0 min (s) 0 ... 2000 min (s)		Depending on the unit selected in F2, the alarm delay is entered in s or min.
F4	Selection of error current	22 mA 2.4 mA		This selection must be made even if all errors are suppressed in F5. If you did not select "0–20 mA" in O211, you may not use "2.4 mA".
F5	Selection of error	1 1 ... 255		This is where the errors are selected that are to trigger an alarm signal. The errors are selected via the error number. Please refer to the table in chapter 7 for the error numbers. The factory settings remain in effect for all errors not edited.
F6	Set alarm contact to be effective for selected errors	yes no		If set to "no", all the other alarm settings are also deactivated (e. g. alarm delay). The settings themselves are retained. This setting only applies to the error selected in F5. Factory setting is no starting with E080!
F7	Set error current to be effective for selected error	no yes		The error current selected in F4 becomes effective or is suppressed in case of error. This setting only applies to the error selected in F5.
F8	Automatic start of cleaning function	no yes		This field does not exist for some errors, see chapter 7.
F9	Return to menu or select next error	next = Next error ←—R		If next is selected, the display returns to F5. If ←—R is selected, the display returns to F.

Factory settings are printed in **bold** face;
base version does not include functions in *italic*.

5.4.2 Check

Polarisation detection

Polarisation effects in the interface between electrode and measuring solution limit the measuring range of conductive conductivity sensors. The Liquisys M transmitter has the ability to detect polarisation effects using an intelligent evaluation process.

PCS alarm (Process Check System)

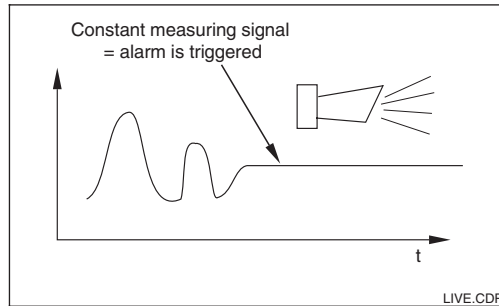

This function is used to examine the measuring signal for deviations. If the measuring signal is constant for a specific period of time (several measured values), an alarm is issued. This type of sensor behaviour may be caused by soiling, etc.



Note:

A current PCS alarm is automatically deleted as soon as the sensor signal changes.

Fig. 5.4 PCS Alarm (live-check)

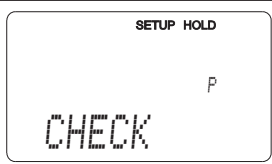
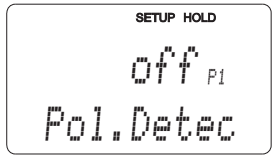
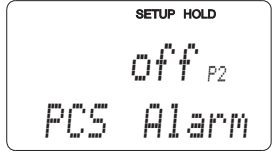
Coding	Field	Selection or range Factory setting	Display	Info
P	Function group CHECK			Settings for sensor and process monitoring.
P1	Switch polarisation detection on or off (conductive only)	off on		Polarisation only occurs with conductive sensors. Polarisation is detected, but not compensated. (Error no.: E071.)
P2	Set PCS Alarm (live-check)	off 1h 2h 4h		This function is used to examine the measuring signal. An alarm is signalled if it does not change for the period selected here. Monitoring limit: 0.3 % of mean value over selected period. (Error no.: E152.)

Factory settings are printed in **bold** face; base version does not include functions in *italic*.

5.5 Relay contact configuration

The relay contacts described below can be selected and configured as required (up to four with four contacts, depending on options installed).

- Limit contactor for measured conductivity value: R2 (1)
- Limit contactor for temperature: R2 (2):
- P(ID) controller: R2 (3)
- Timer for cleaning function: R2 (4)
- Chemoclean function: R2 (5)
- USP 23: R2 (6) (for Plus package, conductive only)

5.5.1 Limit contactor for measured conductivity value and temperature

The relay contacts in the Liquisys M can be assigned different functions.

Switch-on and switch-off points and pickup and dropout delays can be defined for the limit contactor. Moreover, an alarm threshold can be set to issue an error message and to start a cleaning function.

These functions may be used for conductivity as temperature measurement.

Please refer to Fig. 5.5 for a graphic representation of the contact states of any relay or alarm contact.

When the measured value increases (max. function), the relay contact is closed at time t_2 when the switch-on point has been exceeded (t_1) and the pickup delay ($t_2 - t_1$) has expired. When the alarm threshold (t_3) is reached and the alarm delay ($t_4 - t_3$) also has expired, the alarm contact is switched.

When the measured value decreases, the alarm contact is reopened when the measured value drops below the alarm threshold (t_5), and the relay contact also opens (t_7 , after the dropout delay $t_7 - t_6$). When the pickup and dropout delays are set to 0 s, the switch-on and switch-off points are identical to the contact switching points. Settings analogous to the max function can also be made for a min function.

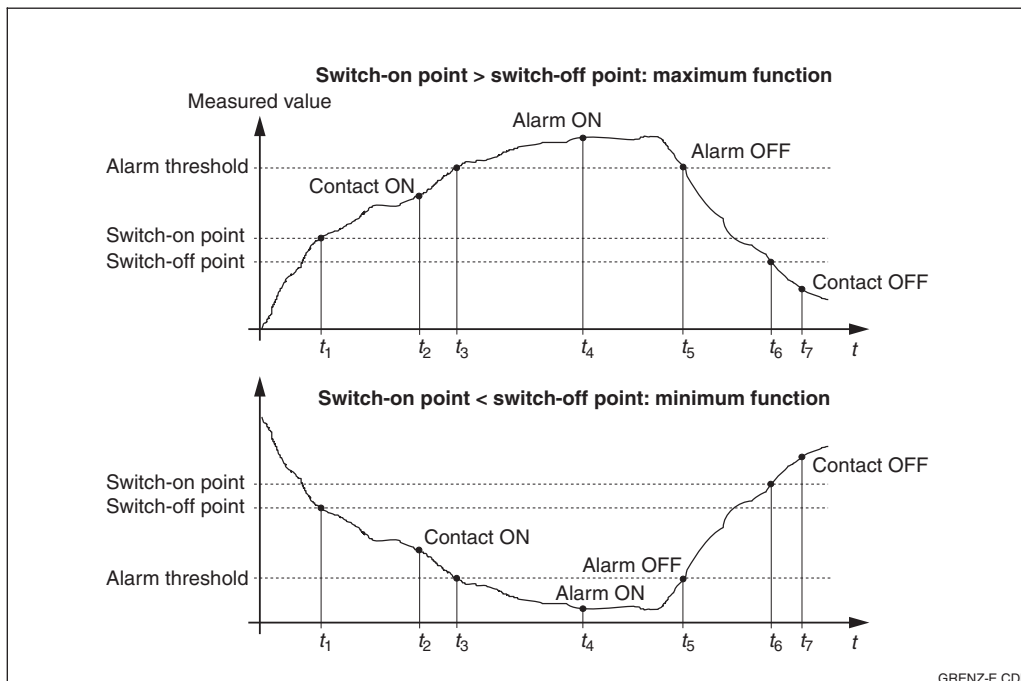

Fig. 5.5 Depiction of alarm functions

5.5.2 P(ID) controller

The Liquisys M supports the definition of various controller functions. On the basis of the PID controller, P, PI, PD and PID controllers can be implemented. The best control response is obtained, using the controller best suited to the application in question.

- **P controller:** Used for simple linear control purposes with small system deviations. Where major changes are to be controlled, overshooting may occur. A control offset is to be expected.
- **PI controller:** Used for processes where overshooting is to be avoided and permanent offsets are not allowed.
- **PD controller:** Used for processes that require quick response and where peaks are to be corrected.
- **PID controller:** Used for processes for which the type of control provided by a P, PI or PD controller is inadequate.

Start-up

- If there is no previous experience for the control parameter settings, values should be used which guarantee maximum control loop stability (see table).
- For optimisation, the control gain K_p is reduced until the control variable overshoots slightly.
- Then K_p is increased somewhat, and the T_n setting is reduced to obtain the shortest possible correction time without overshooting. T_v must also be adjusted in the case of fast correction times.

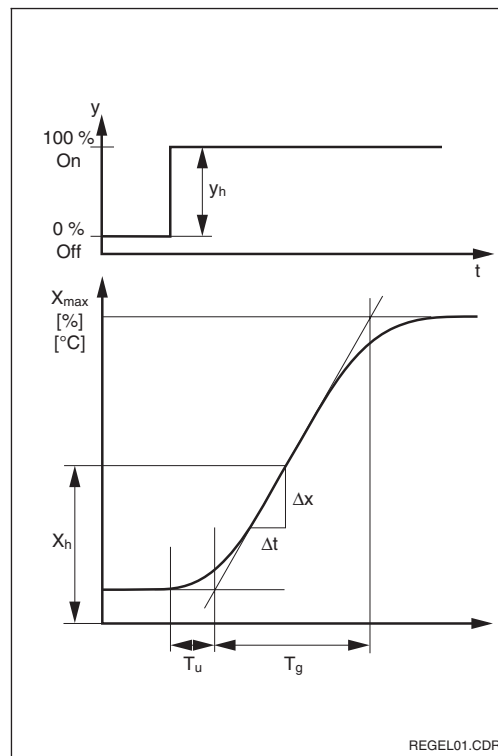

Fig. 5.6 Control characteristic

Adjustments of P(ID) controller

Three parameters can be adjusted in the case of a PID controller:

- the control gain K_p (P influence)
- the integral action time T_n (I influence)
- the derivative action time T_v (D influence)

Step response of process

- y = set value
- y_h = control range
- T_u = delay time [s]
- T_g = recovery time [s]

$$V_{max} = \frac{X_{max} - \Delta x}{T_g} = \frac{\Delta x}{\Delta t}$$

= max. slew rate of control variable [K/s]

- X_{max} = maximum process value
- X_h = controller adjustment range

Controller characteristics

$$K = \frac{V_{max}}{X_h} \cdot T_u$$

Recommendable settings for all types

Controller response	K_p	T_v [min]	T_n [min]
P	1·K	0	0
PI	2,6·K	0	6 T_u
PD	0,5 K·	T_u	0
PID	1,7 K·	2 T_u	2 T_u

$T_v = 0$: component not calculated

$T_n = 0$: component not calculated

Checking and fine tuning of parameter settings using a recorder

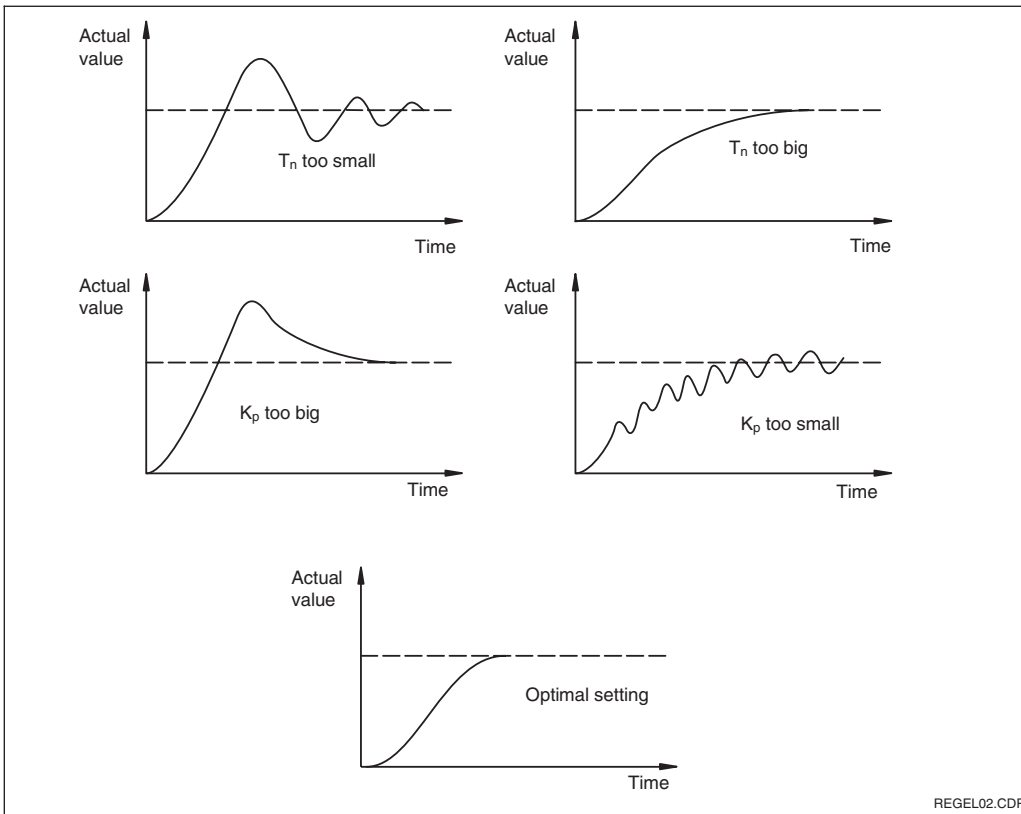

Fig. 5.7 Optimisation of settings for T_n and K_p

Actuating signal outputs (R237 ... R2310)

The control contact in question outputs a switched signal whose intensity corresponds to the controller's output. A distinction is made according to the type of signal output:

- Pulse length modulation**
 The greater the calculated control output, the longer the contact in question remains picked up. The period can be adjusted between 0.5 and 99 s. Pulse-length modulated outputs are used to control solenoid valves.
- Pulse frequency modulation**
 The greater the calculated control output, the higher the switching frequency of the contact. The maximum switching frequency $1/T$ can be adjusted between 60 and 180 min^{-1} . The ON period t_{ON} is constant. Pulse frequency-modulated outputs are used to control solenoid-operated metering pumps.

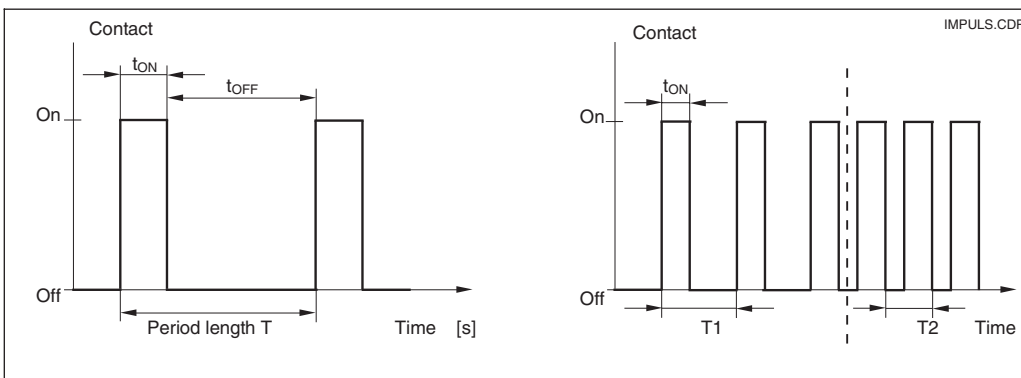

Fig. 5.8 Signal of a pulse length-modulated (left) and a pulse frequency-modulated control contact (right)

Control characteristic for direct and inverted control action

Field R236 offers two control characteristics for selection which have the effects shown in the following diagram.

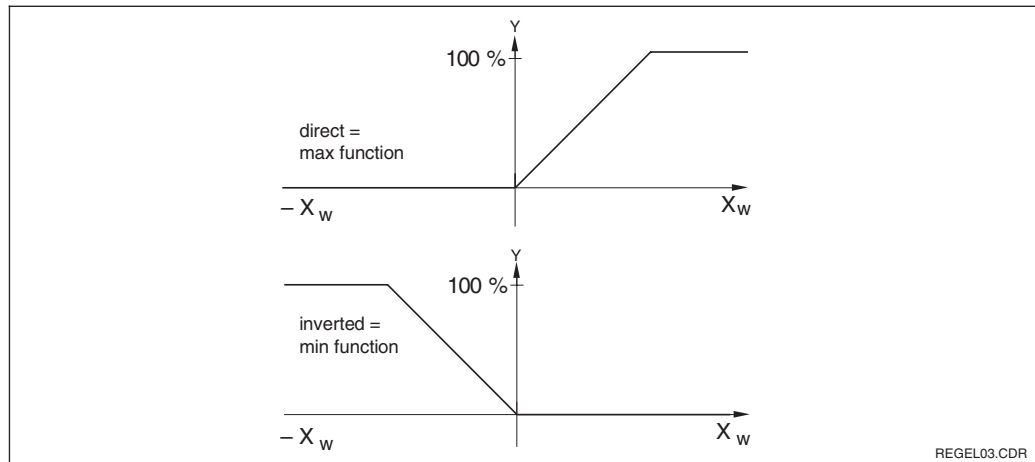

Fig. 5.9 Control characteristic of a proportional controller with direct and inverted control action

5.5.3 USP 23 Function (conductive only)

The Liquisys M can measure and monitor the uncompensated conductivity (Field R2(6)) according to USP (“United States Pharmacopeia”) guidelines.

The measurement is performed as follows:

- Measurement of uncompensated conductivity
- Compare the actual measured value with a monitoring value for pure water (see table)
- Temperature measurement at place of conductivity measurement
- Rounding temperature to the next 5 °C step
- Determination of applicable monitoring value from a table (see below)
- Alarm signalling in the event the monitoring value is exceeded.



Note:

- To use the USP 23 function, the device must be equipped with relays.
- For alarm output, activate the fault-signalling contact or the error current in Field F5 - F7.
- The prealarm is only active, if you make the switch-on point (R262) greater than the switch-off point (R263).
- Should the measured values deviate from those above, the error message 151 is triggered.

Temperature [°C]	Conductivity [µS/cm]	Temperature [°C]	Conductivity [µS/cm]
0	0.6	55	2.1
5	0.8	60	2.2
10	0.9	65	2.4
15	1.0	70	2.5
20	1.1	75	2.7
25	1.3	80	2.7
30	1.4	85	2.7
35	1.5	90	2.7
40	1.7	95	2.9
45	1.8	100	3.1
50	1.9		

5.5.4 Timer for cleaning function

This function can be used to implement a simple cleaning routine. The user can specify a time interval after which cleaning is to start; i.e. only constant intervals can be defined. More extended cleaning functions can be implemented in conjunction with the Chemoclean function (version with four contacts, see chapter 5.5.5).



Note:

The timer and Chemoclean do not work independently of each other. Whilst one of the functions is active, the other cannot be started.

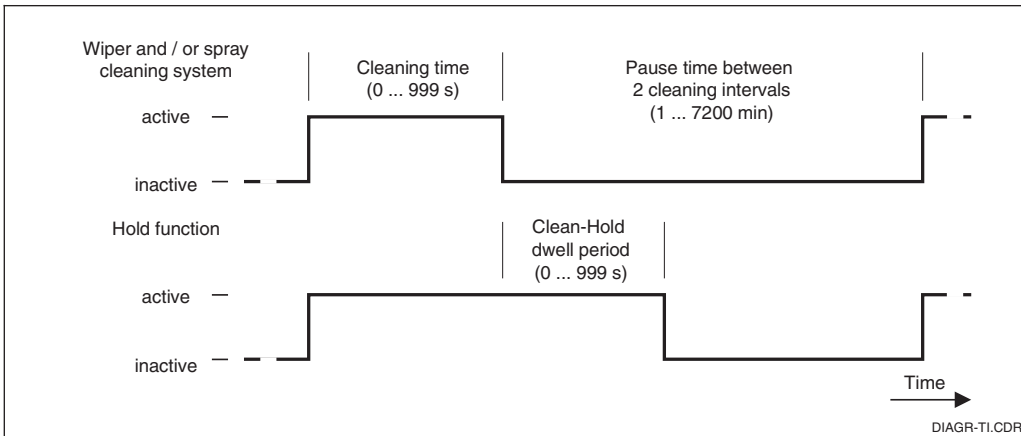

Fig. 5.10 Relationship among cleaning time, pause time and hold dwell period

5.5.5 Chemoclean function

Just like the timer function, Chemoclean can also be used to start a cleaning cycle. By comparison, the function scope is extended by an option for defining cleaning and rinsing intervals. Thus, irregular cleaning with different repeat cycles is possible, and cleaning times with post-rinse times can be individually defined.



Note:

- The Chemoclean function is only available with relays 3 (water) and 4 (cleaner).
- Abortion of the cleaning process is always followed by a post-rinse time.
- When "Economy" is selected, cleaning is performed with water only.

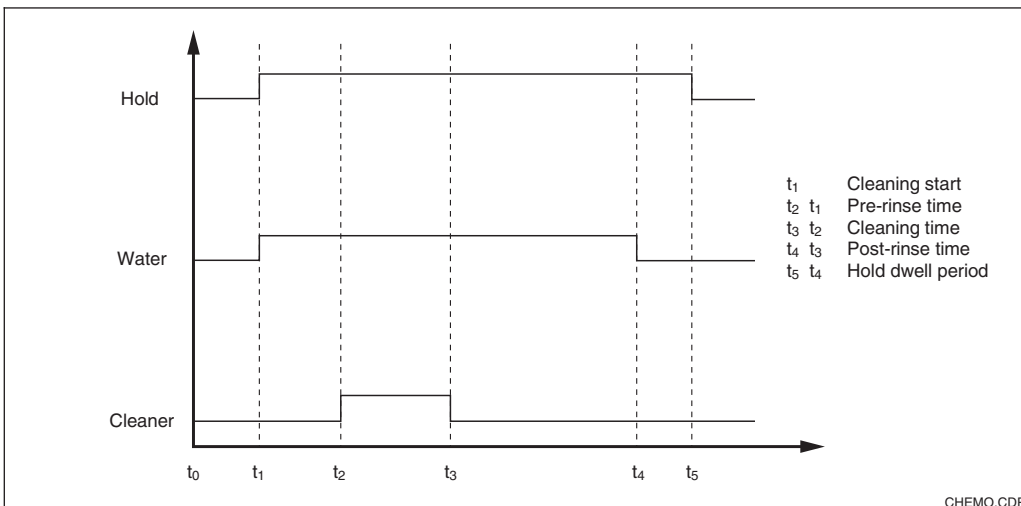
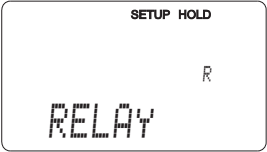
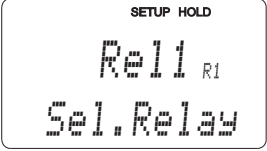
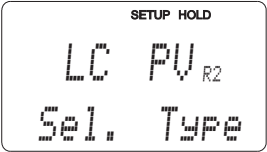
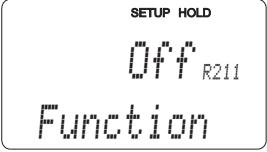
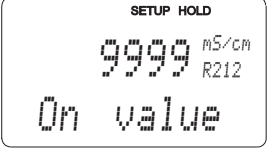
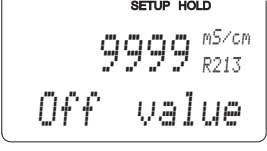
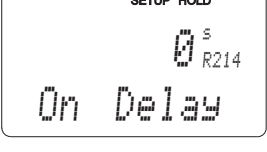
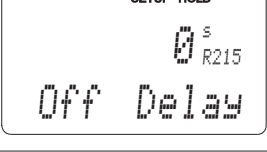
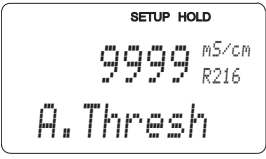
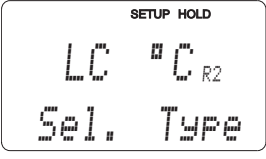
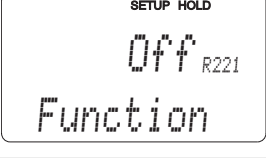
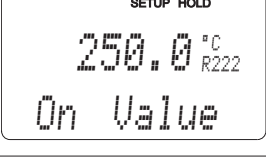
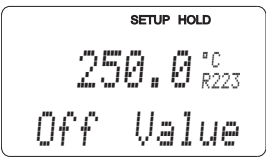
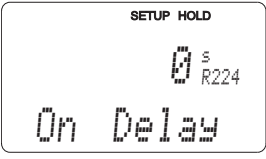
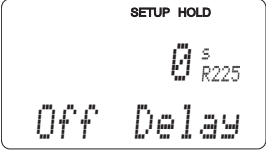

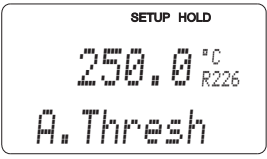
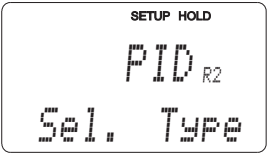
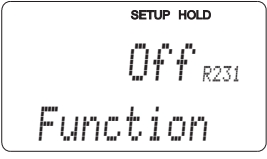
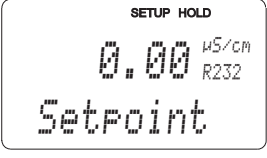
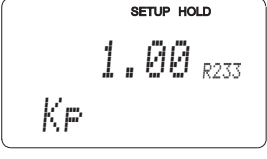
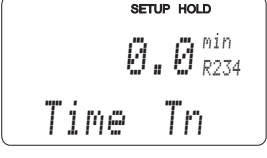
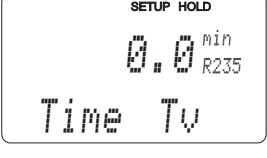

Fig. 5.11 Cleaning cycle sequence

Coding	Field	Selection or range Factory setting	Display	Info
R	Function group RELAY			Relay contacts can be selected and adjusted.
R1	Selection of contact to be configured	Rel1 <i>Rel2</i> <i>Rel3</i> <i>Rel4</i>		Rel3 (water) and Rel4 (cleaner) are only available on transmitter equipped accordingly. If Chemoclean is selected as the cleaning type, Rel4 is not available.
R2 (1)	Configuration limit contactor for conductivity, resistance or concentration measurement	LC PV = Limit contactor cond. (1) LC °C = Limit contactor T (2) PID = PID controller (3) Timer (4) <i>Clean = Chemoclean (5)</i> <i>USP23 (6)</i>		PV = Process value Selecting Rel4 in Field R1 means that Clean = Chemoclean cannot be selected. Confirmation with ENTER switches off a different, already switched-on function and its settings are reset to the default.
R211	Switch function of R2 (1) off or on	Off On		All settings are retained.
R212	Enter contact switch-on point	cond/ind: 9999 mS/cm MOhm: 200 MΩ.cm Conc: 9999 % Whole measuring range		Never set the switch-on point and switch-off point to the same value. (Only the operating mode selected in A1 appears.)
R213	Enter contact switch-off point	cond/ind: 9999 mS/cm MOhm: 200 MΩ.cm Conc: 9999 % Whole measuring range		The switch-off point entry selects a max contact (switch-off point < switch-on point) or a min contact (switch-off point > switch-on point), thereby implementing an always required hysteresis function (see Fig. 5.5).
R214	Enter pickup delay	0 s 0 ... 2000 s		
R215	Enter dropout delay	0 s 0 ... 2000 s		

Factory settings are printed in **bold** face;
base version does not include functions in *italic*.

Coding		Field	Selection or range Factory setting	Display	Info
	R216	Enter alarm threshold (as an absolute value)	cond/ind: 9999 mS/cm MOhm: 200 MΩ·cm Conc: 9999 % entire measuring range		<p>When the alarm threshold is exceeded/undershot, the transmitter issues an alarm with an error message and error current (note alarm delay).</p> <p>When defining the min contact, the alarm threshold must be set to a lower value than the switch-off point.</p>
	R2 (2)	Configure limit contactor for temperature measurement	LC PV = Limit contactor cond. (1) LC PV °C = Limit contactor T (2) PID = PID controller (3) Timer (4) <i>Clean = Chemoclean</i> (5) <i>USP23</i> (6)		Confirmation with ENTER switches off a different, already switched-on function and its settings are reset to the default.
	R221	Switch function of R2 (2) off or on	Off On		
	R222	Enter switch-on temperature	250.0 °C -35.0 ... 250.0 °C		Never set switch-on point and switch-off point to the same value!
	R223	Enter switch-off temperature	60.0 C 10.0 ... 60.0 C		The switch-off point entry selects a max contact (switch-off point < switch-on point) or a min contact (switch-off point > switch-on point), thereby implementing an always required hysteresis function (see Bild 5.5)
	R224	Enter pickup delay	0 s 0 ... 2000 s		
	R225	Enter dropout delay	0 s 0 ... 2000 s		

Factory settings are printed in **bold** face;
base version does not include functions in *italic*.

Coding		Field	Selection or range Factory setting	Display	Info
	R226	Enter alarm threshold (as an absolute value)	250.0 °C -35.0 ... 250.0 °C		When the alarm threshold is exceeded/undershot, the transmitter issues an alarm with an error message and error current (note alarm delay). When defining the min contact, the alarm threshold must be set to a lower value than the switch-off point.
	R2 (3)	P(ID) controller configuration	LC PV = Limit contactor cond. (1) LC °C = Limit contactor T (2) PID = PID controller (3) Timer (4) <i>Clean = Chemoclean</i> (5) <i>USP23</i> (6)		Confirmation with ENTER switches off a different, already switched-on function and its settings are reset to the default.
	R231	Switch function of R2 (3) off or on	Off On		
	R232	Enter set point	cond/ind: 0.00 µS/cm MOhm: 0.00 kΩ·cm Conc: 0.00 % entire measuring range		The set point is the value to be maintained by the control. The controller will restore this value if there is a deviation up or down.
	R233	Enter control gain K _p	1.00 0.01 ... 20.00		See chapter 5.5.2.
	R234	Enter integral action time T _n (0.0 = no I component)	0.0 min 0.0 ... 999.9 min		See chapter 5.5.2. Each hold sets the I component to zero. Hold can be deactivated in S2, but not for Chemoclean and timer!
	R235	Enter derivative action time T _v (0.0 = no D component)	0.0 min 0.0 ... 999.9 min		See chapter 5.5.2.
	R236	Selection of controller characteristic	dir = direct inv = inverted		Setting may or may not be required depending on control deviation (up or down deviation, see chapter 5.5.2).

Factory settings are printed in **bold** face;
base version does not include functions in *italic*.

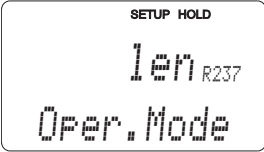
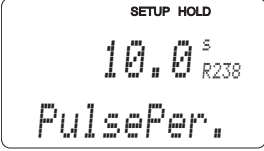
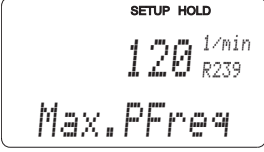
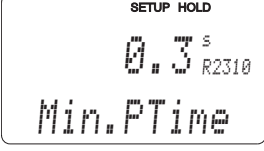
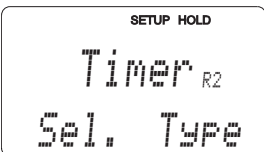
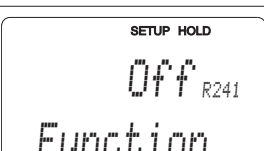
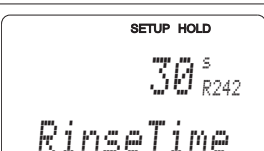
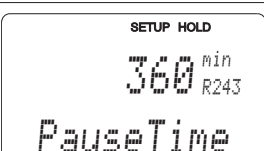
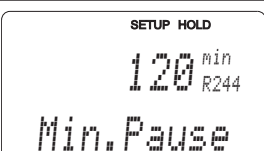
Coding	Field	Selection or range Factory setting	Display	Info
R237	Selection of pulse length or pulse frequency	len = Pulse length freq = Pulse frequency		Pulse length e.g. for solenoid valve, pulse frequency e.g. for solenoid-operated metering pump (see chapter 5.5.2).
R238	Enter pulse interval	10.0 s 0.5 ... 999.9 s		This field only appears if pulse length is selected in R237. When pulse frequency is selected, R238 is skipped and input continues in R239.
R239	Enter maximum pulse frequency of actuator	120 min⁻¹ 60 ... 180 min ⁻¹		This field only appears if pulse frequency is selected in R237. When pulse length is selected, R239 is skipped, and input continues in R2310.
R2310	Enter minimum ON time t _{ON}	0.3 s 0.1 ... 5.0 s		This field only appears if pulse length is selected in R237.
R2 (4)	Configure cleaning function (timer)	LC PV = Limit contactor cond. (1) LC °C = Limit contactor T (2) PID = PID controller (3) Timer (4) <i>Clean = Chemoclean (5)</i> <i>USP23 (6)</i>		Cleaning is performed using only <i>one</i> cleaning agent (usually water); see Fig. 5.10. Confirmation with ENTER switches off a different, already switched-on function and its settings are reset to the default.
R241	Switch function of R2 (4) off or on	Off On		
R242	Enter rinse / cleaning time	30 s 0 ... 999 s		The hold and relay settings are activated for the period of time specified here.
R243	Enter pause time	360 min 1 ... 7200 min		The pause time is the time between two cleaning cycles (see chapter 5.5.5).
R244	Enter minimum pause time	120 min 1 ... 3600 min		The minimum pause time prevents continuous cleaning when the cleaning trigger is present.

Factory settings are printed in **bold** face;
base version does not include functions in *italic*.

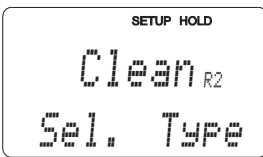
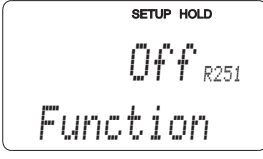
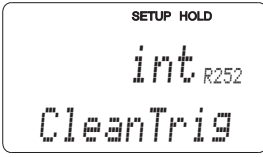
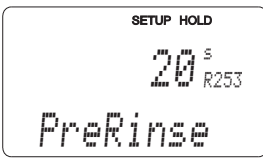
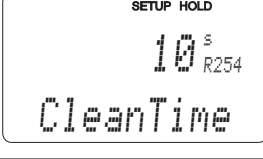
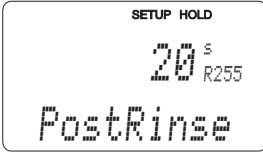
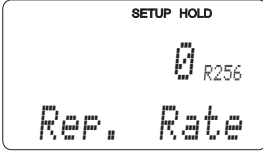
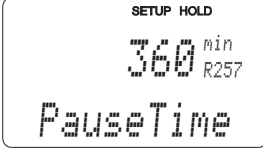
Coding	Field	Selection or range Factory setting	Display	Info
R2 (5)	Configure cleaning with Chemoclean (on version with four contacts and appropriate assignment of contacts 3 and 4)	LC PV = Limit contactor cond. (1) LC °C = Limit contactor T (2) PID = PID controller (3) Timer (4) Clean = Chemoclean (5) <i>USP23</i> (6)		See chapter 5.5.5. Contact 3 = Water, Contact 4 = Cleaner. Confirmation with ENTER switches off a different, already switched-on function and its settings are reset to the default.
R251	Switch function of R2 (5) off or on	Off On		
R252	Selection of start pulse	int = internal (timer-contr.) ext = external (digital input 2) i+ext = intern. + extern. i+stp = internal, suppressed by external		There is no real-time clock. External suppression is required for irregular time intervals (e.g. weekends).
R253	Enter pre-rinse time	20 s 0 ... 999 s		Water is used for rinsing.
R254	Enter cleaning time	10 s 0 ... 999 s		Cleaning agent and water are used for cleaning.
R255	Enter post-rinse time	20 s 0 ... 999 s		Water is used for rinsing.
R256	Enter number of repeat cycles	0 0 ... 5		R253 ... R255 is repeated.
R257	Enter pause time	360 min 1 ... 7200 min		The pause time is the time between two cleaning cycles.

Factory settings are printed in **bold** face;
base version does not include functions in *italic*.

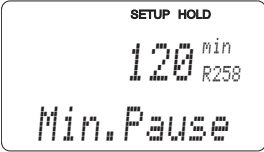
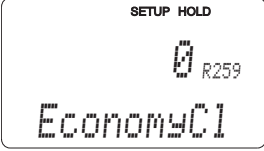
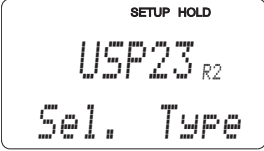
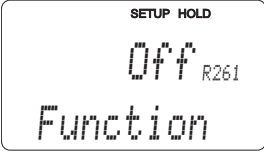
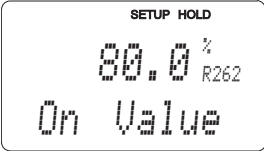
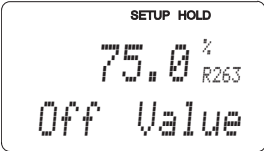
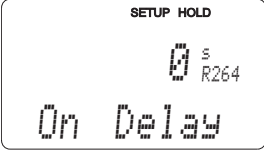
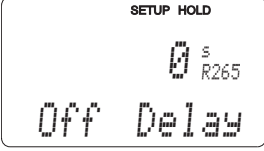
Coding	Field	Selection or range Factory setting	Display	Info
R258	Enter minimum pause time	120 min 1 ... R357 min		The minimum pause time prevents continuous cleaning when the external cleaning trigger is present.
R259	Enter number of cleaning cycles without cleaning agent (Economy function)	0 0 ... 9		Cleaning with cleaner can be followed by up to 9 cleaning cycles that use only water until the next cleaning cycle with cleaner is performed.
R2 (6)	Configure USP contact (only for Plus package and with relay)	LC PV = Limit contactor cond. (1) LC °C = Limit contactor T (2) PID = PID controller (3) Timer (4) <i>Clean = Chemoclean (5)</i> USP23 (6)		The USP contact can be configured as a pre-alarm, i.e., it issues an alarm before the limit is reached. When an alarm is output, the error no. E151 is displayed. Confirmation with ENTER switches off a different, already switched-on function and its settings are reset to the default.
R261	Switch function of R2 (6) off or on	Off On		
R262	Alarm threshold: Enter switch-on point	80.0 % 00 ... 100.0 %		The pre-alarm effects a contact query. Should the alarm value be reached (100.0 %) the alarm relay also responds. Example: At 15 °C and 1.0 µS/cm with the setting 80.0 %, a prealarm is also triggered at 0.8 µS/cm (comp. table chap. 5.5.3).
R263	Alarm threshold: Enter switch-off point	75.0 % 0.0 ... 100.0 %		Prealarm is only active if value R262 > R263.
R264	Alarm threshold: Enter pickup delay	0 s 0 ... 2000 s		
R265	Alarm threshold: Enter dropout delay	0 s 0 ... 2000 s		

Factory settings are printed in **bold** face;
base version does not include functions in *italic*.

5.6 Temperature compensation

The temperature coefficient specifies the change in conductivity per degree of temperature change. It depends on the chemical composition of the medium and the temperature itself. In order to compensate for this dependence, four different compensation types can be selected in the Liquisys M:

Linear compensation

The change between two temperature points is considered to be constant, i.e. $\alpha = \text{const}$. The α value can be edited for the linear compensation type. The reference temperature is 25 °C.

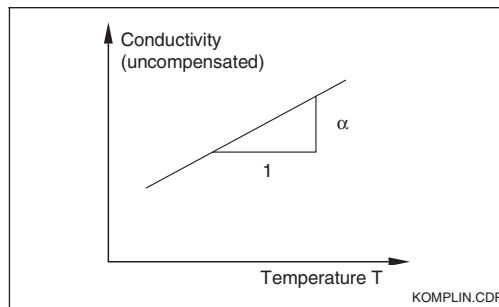

NaCl compensation

The NaCl compensation (according to IEC 746) based on a fixed nonlinear curve that defines relationship between the temperature coefficient and the temperature. This curve is used for small concentrations.

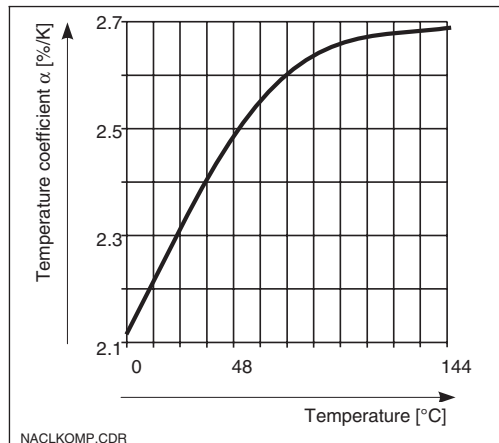

Ultrapure water compensation

Just like the NaCl compensation, the ultrapure water compensation is based on a nonlinear curve stored in the instrument. This curve is split up into NaCl solution and ultrapure water compensation. These are calculated separately but then used together to determine in the overall relationship.

Temperature compensation with table

With using the alpha table function for temperature compensation the following conductivity data of the process medium to be measured is required:

Value pairs from temperature T and conductivity κ for $T_0 = 25$ °C and for temperatures, which occur in the process.

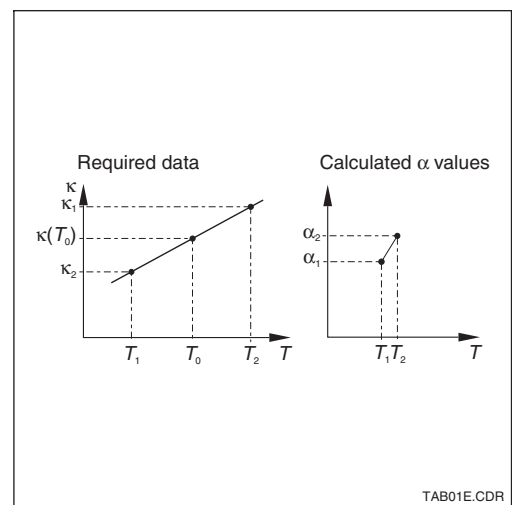

For the temperatures relevant in your process, use the following equation to calculate the α values (not to determine a α value for 25 °C is neither sensible, nor could you edit a table without this value).

$$\alpha = \frac{100}{\kappa(T_0)} \cdot \frac{\kappa(T) - \kappa(T_0)}{T - T_0}; T \neq T_0.$$

The T - α value pairs obtained are edited in the table in the measuring device and then you can commence measurement.

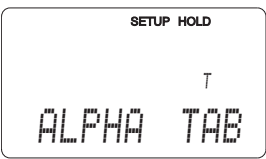
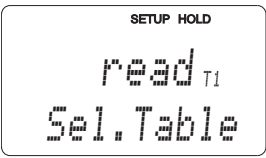
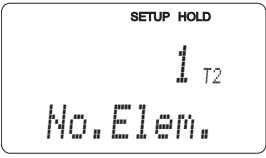
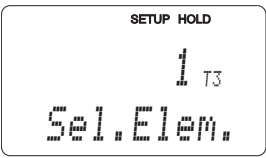
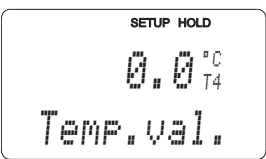
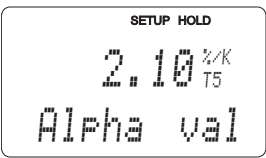
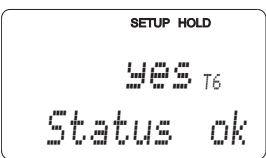
Coding	Field	Selection or range Factory setting	Display	Info
T	Function group ALPHA TABLE			
T1	Selection of table option	read edit		
T2	Enter number of table value pairs	1 1 ... 10		Up to 10 value pairs can be entered in the α table. These are numbered from 1 ... 10 and can be edited individually or in sequence.
T3	Selection of table value pair	1 1 ... Quantity of table value pairs Finished		The function chain T3 ... T5 will run through as many times as correspond to the value in T2. "Finished" appears as the last step. After confirmation, the system jumps to T6.
T4	Enter temperature value (x value)	0.0 °C -35.0 ... 250.0 °C		The temperature values must have a minimum distance of 1 K. Factory setting for the x value of the table value pairs: 0.0 °C; 10.0 °C; 20.0 °C; 30.0 °C ...
T5	Enter temperature coefficient α (y value)	2.10 %/K 0.00 ... 20.00 %/K		
T6	Enter whether or not the table status is ok	yes no		Return to T. If not, then set table correctly (all previous settings are kept) or back to measurement mode (this makes the table invalid).

Factory settings are printed in **bold** face;
base version does not include functions in *italic*.

5.7 Concentration measurement

Liquisys M can convert conductivity values to concentration values. For this, set the operating mode to Concentration Measurement (see Field A1).

Then, you must enter to which basic data the concentration calculation should be based into the measuring device. For the most common substances, the required data is already saved in your device. You can select one of these substances in Field K1.

If you want to specify the concentration of a sample, which is not saved in the device, this is also possible. In this case, you require the conductivity characteristics of the medium. If you do not have this data in the datasheets, you can also determine the characteristics yourself quite simply: Produce samples of the

medium in the concentrations in which they appear in the process. Measure the uncompensated conductivity of these samples at temperatures which also occur in the process.

Process temperature changeable:

Should these temperature changes be included in the concentration measurement, then the conductivity of *each* sample created must be measured at least *two different temperatures* (minimum and maximum temperatures of the process).

Process temperature constant:

Measure the differently concentrated samples at this process temperature.

Then you should obtain measuring data looking as follows:

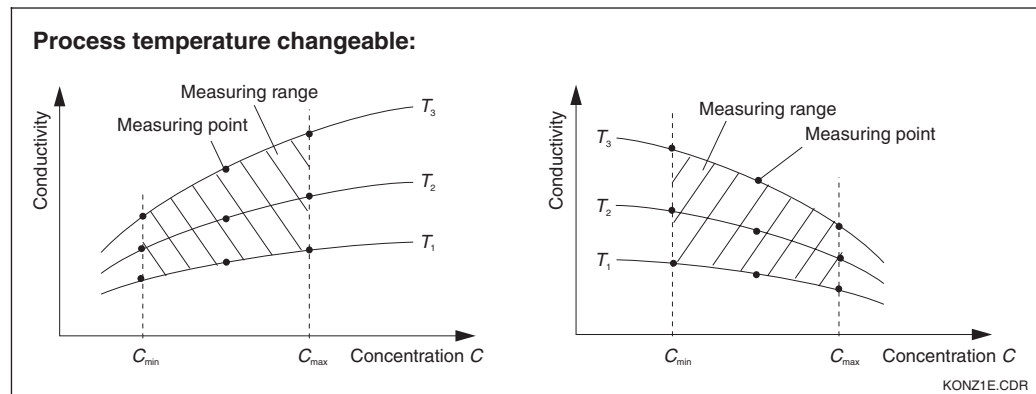

Fig. 5.12 Measured data in the case of changeable temperature (represented qualitatively)

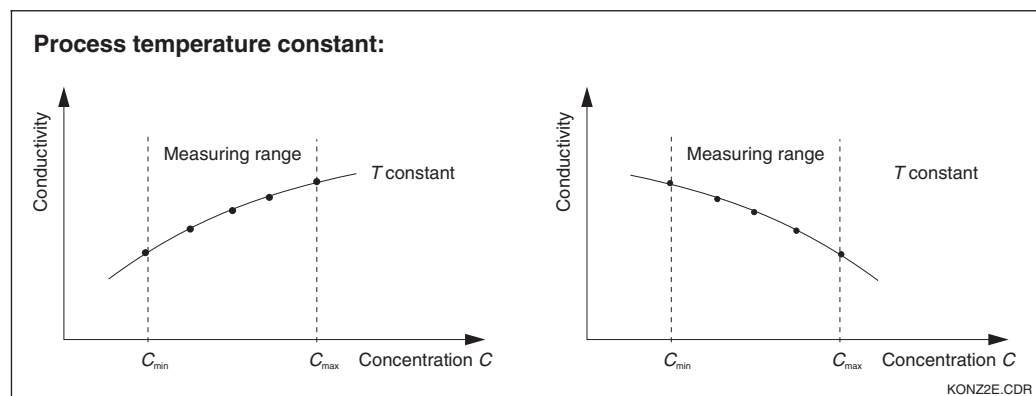

Fig. 5.13 Measured data in the case of constant temperature (represented qualitatively)

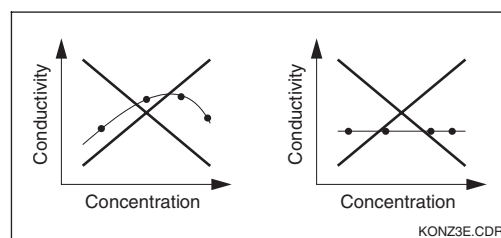

Fig. 5.14 Unpermitted curve shapes

The characteristics obtained from the measuring points must have strictly monotonous rising or falling slope in the range of the process conditions, i.e. they may not show the maximum, minimum or ranges of constant behaviour. The curves in the diagram to the left are therefore unpermissible.

Value entry

Now enter the three parameters in Fields K6 to K8 for each measured sample (value triplet of conductivity, temperature and concentration).

Process temperature changeable:

At least two samples, i.e. two different concentrations, are required. For *each* of these samples, you must enter values for *at least two temperatures* (minimum distance 0.5 °C). The temperature values of the differently concentrated samples must be identical (isothermic characteristics). This provides a minimum of four value triplets.

Process temperature constant:

Enter at least two value triplets in the device. These temperature values of the triplets you enter must be identical.

**Note:**

If the measured values for conductivity or temperature in measuring operation lie outside the values entered in the concentration table (see Fig. 5.12 and 5.13), this has a negative effect on accuracy and the device generates an error message. Therefore, when determining the characteristics, you should observe the limit values of the process.

If you enter an additional value triplet of 0 µS/cm and 0% for each temperature used, you can work from the start of measuring range with sufficient accuracy and without an error message.

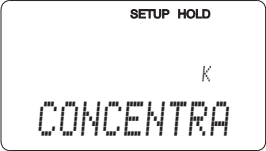
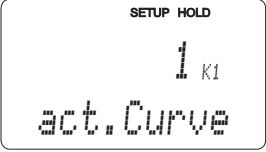
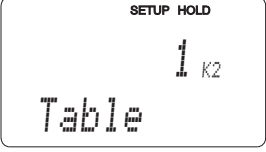
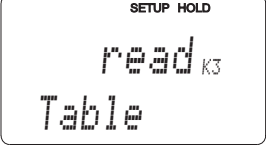
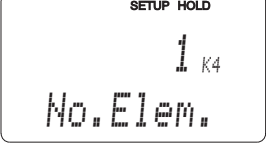
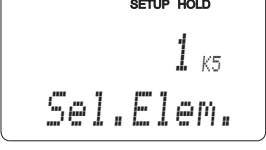
Coding	Field	Selection or range Factory setting	Display	Info
K	Function group CONCENTRATION			Four different concentration fields can be entered in this function group.
K1	Selection of concentration curve, to be used to calculate the display value	1 1 ... 4		The curves are independent of each other. Therefore, four different curves can be defined.
K2	Selection of table to be edited	1 1 ... 4		When editing a curve, another curve should be used to calculate the corresponding values (see K1).
K3	Selection of table option	Read Edit		This selection applies to all concentration curves.
K4	Enter number of triplets	1 1 ... 10		Each triplet consists of three numeric values.
K5	Selection of triplet	1 1 ... Number of triplets in K4		Any triplet can be edited.



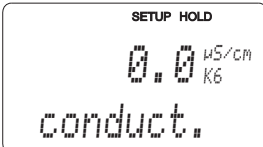
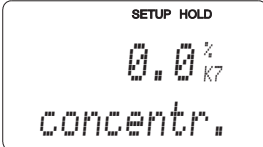
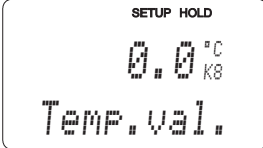
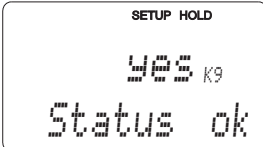

Factory settings are printed in **bold** face;
base version does not include functions in *italic*.

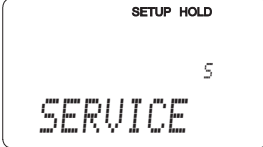
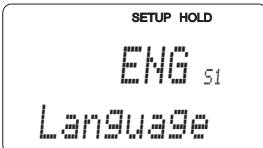
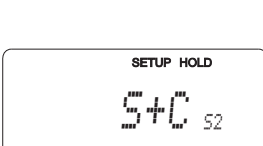
Coding	Field	Selection or range Factory setting	Display	Info
K6	Enter uncompensated conductivity value	0.0 $\mu\text{S/cm}$ 0.0 ... 9999 mS/cm		The function chain K5 ... K8 will run through automatically as many times as corresponds to the value in K4. Then the system jumps to K9.
K7	Enter concentration value for K6	0.00 % 0.00 ... 99.99 %		Measuring unit selected as in A2.
K8	Enter temperature value for K6	0.0 °C -35.0 ... 250.0 °C		
K9	Enter whether or not the table status is ok	yes no		Return to K. If not, then set table correctly (all previous settings are kept) or back to measurement mode (this makes the table invalid).

5.8 Service

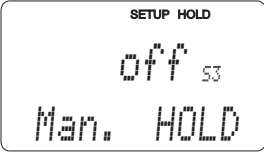
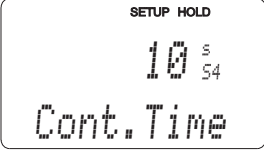
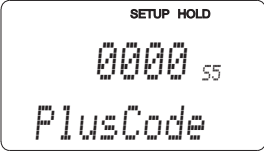
Coding	Field	Selection or range Factory setting	Display	Info
S	Function group SERVICE			
S1	Selection of language	ENG = English GER = German FRA = French ITA = Italian NEL = Dutch ESP = Spanish		This field must be set configured once during device start-up. After confirmation with ENTER you can exit S1 and continue.
S2	Hold configuration	S+C = during setup and calibration CAL = during calibration Setup = during setup No = no hold		S = setup, C = calibration.

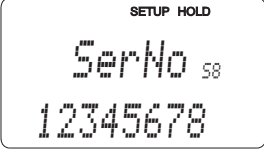
Factory settings are printed in **bold** face;
base version does not include functions in *italic*.

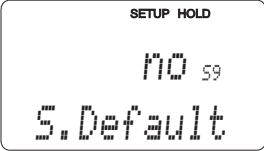
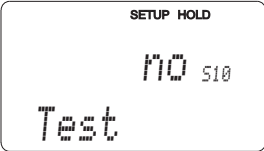
Coding	Field	Selection or range Factory setting	Display	Info
S3	Manual hold	Off On		The setting remains active even after a power failure.
S4	Enter hold dwell period	10 s 0 ... 999 s		
S5	SW upgrade: Enter release code for Plus packet	0000 0000 ... 9999		The code is located on the nameplate (see Figs. 1.1 and 1.2). Entry of an incorrect code returns you to the measurement menu. The number is edited with the PLUS or MINUS key and confirmed with the ENTER key.
S6	SW upgrade: Enter release code for Chemoclean	0000 0000 ... 9999		The code is located on the nameplate (see Figs. 1.1 and 1.2). Entry of an incorrect code returns you to the measurement menu. The number is edited with the PLUS or MINUS key and confirmed with the ENTER key.
S7	Order number is displayed			The order code is changed automatically to reflect an upgrade.
S8	Serial number is displayed			
S9	Reset of instrument (restore default values) 	no Sens = Sensor data Facy= Factory settings		Facy= All data except Language (Field S1) are erased and reset to the factory setting! Sens = The sensor data are erased.
S10	Perform instrument test	no displ = display test		

Factory settings are printed in **bold** face;
base version does not include functions in *italic*.

5.9 E+H Service

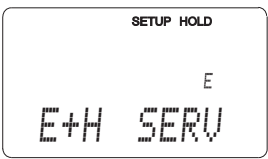
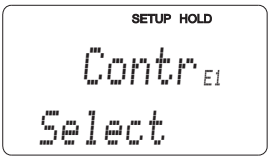
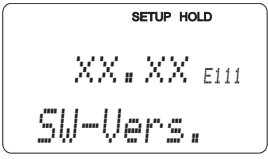
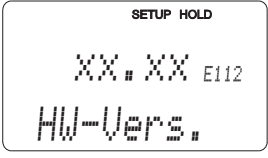
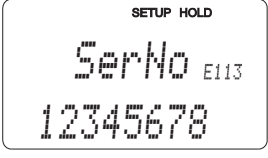
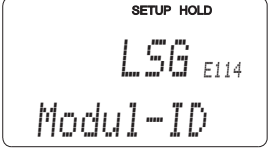
Coding	Field	Selection or range Factory setting	Display	Info
E	Function group E+H SERVICE			
E1	Selection of module	Contr = controller (1) Trans = transmitter (2) Main = power unit (3) Rel = relay (4)		
E111 E121 E131 E141	Software version is displayed			This field cannot be edited.
E112 E122 E132 E142	Hardware version is displayed			This field cannot be edited.
E113 E123 E133 E143	Serial number is displayed			This field cannot be edited.
E114 E124 E134 E144	Module name is displayed			This field cannot be edited.

5.10 Interfaces

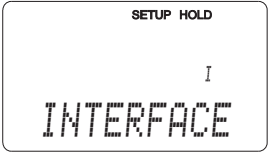
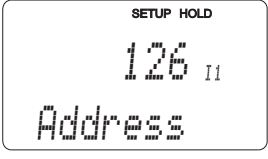
Coding	Field	Selection or range Factory setting	Display	Info
I	Function group INTERFACE			
I1	Entry of address	Address HART: 0 ... 15 or PROFIBUS: 1 ... 126		For communication only.

Factory settings are printed in **bold** face;
 base version does not include functions in *italic*.

5.11 Calibration

This function group is used to calibrate the transmitter. Two different types of calibration are possible:

- Calibration by measurement in a calibration solution of a known conductivity.
- Calibration by entry of the exact cell constant of the conductivity sensor.





Note:

- **For conductive sensors, only menu points C121 to C126 are relevant.**
- The instrument is automatically switched to hold during calibration (factory setting).



Note:

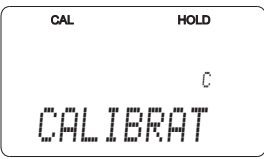

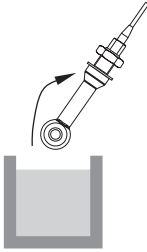
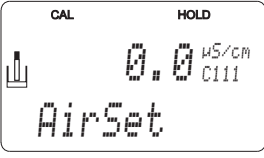
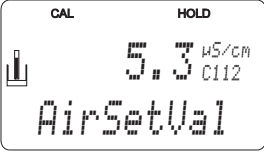
- If the calibration procedure is aborted by pressing the PLUS and MINUS keys at the same time (return to C114, C126 or C136) or if the calibration is faulty, then the previous calibration data are reinstated. A calibration error is indicated by the "ERR" message and flashing of the sensor symbol on the display. Repeat calibration!
- After calibration, the system returns to measuring mode. During the hold delay time (Field S4), the Hold symbol appears in the display.

Coding	Field	Selection or range Factory setting	Display	Info
C	Function group CALIBRATION			For conductive measurement, Airs and InstF are not available.
C1 (1)	Calibration of inductive cells with a ring-shaped opening	Airs = Airset (1) <i>Cellc = Cell constant</i> (2) <i>InstF = Installation factor</i> (3)		When commissioning measuring cells, you must always carry out an airset. The calibration of the cell is to be performed in air and the cell must be dry.
Remove sensor from the medium and dry completely .				
C111	Residual coupling Start calibration (Airset)	Current measured value		Start calibration with CAL.
C112	Residual coupling is displayed (Airset)	-80.0 ... 80.0 μ S		Residual coupling of measuring system (sensor and transmitter).

Factory settings are printed in **bold** face; base version does not include functions in *italic*.

Coding		Field	Selection or range Factory setting	Display	Info
C1	C113	Calibration status is displayed	o.k. E xxx		If the calibration status is not o.k., then the second display line shows an explanation of the error.
	C114	Store calibration result	yes no new		If C113 = E xxx, then only no or new . If new, return to C. If yes/no, return to "Measurement".
	C1 (2)	Calibration of cell constant	Airs = Airset (1) Cellc = Cell constant (2) <i>InstF = Installation factor (3)</i>		
Immerse sensor in the calibration solution.					The sensor should be immersed at a sufficient distance from the vessel wall (installation factor has no influence).
C12	C121	Enter calibration temperature (MTC)	25.0 °C -35.0 ... 250.0 °C		Only exists, if B1 = fixed.
	C122	Enter α value of the calibration solution	2.10 %/K 0.00 ... 20.00 %/K		This value is given with each calibration solution.
	C123	Enter correct conductivity value of the calibration solution	Current measured value 0.0 ... 9999 mS/cm		The practicable range is depends on the sensor, i.e. the calibration solution should be approx. 40 % of the measuring range determined by the cell (see chapter 9, Fig. 9.1). The display unit is always in mS/cm.
	C124	Calculated cell constant is displayed	0.0025 ... 99.99 cm ⁻¹		The calculated cell constant is displayed and entered to A5.
	C125	Calibration status is displayed	o.k. E xxx		If the calibration status is not o.k., then the second display line shows an explanation of the error.

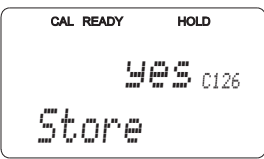
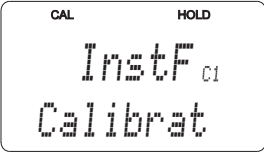
Factory settings are printed in **bold** face;
base version does not include functions in *italic*.

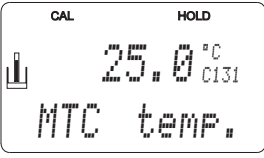
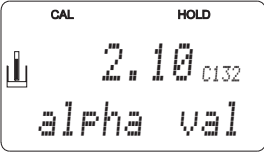
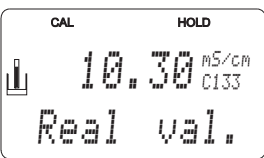
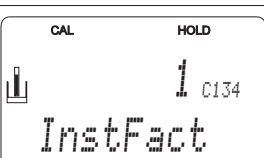
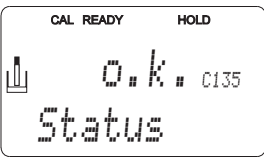
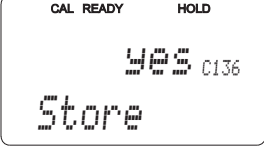
Coding		Field	Selection or range Factory setting	Display	Info
	C126	Store calibration result	yes no new		If C125 = E xxx, then only no or new . If new, return to C. If yes/no, return to "Measurement".
	C1 (3)	Calibration with sensor adaptations for inductive sensors (only with Plus package)	Airs = Airset (1) Cellc = Cell constant (2) InstF = Installation factor (3)		Sensor calibration with compensation of wall influences.
The sensor remains at the place of installation.					
	C131	Enter calibration temperature (MTC)	25.0 °C -35.0 ... 250.0 °C		Only exists, if B1 = fixed.
	C132	Enter α value of calibration solution	2.10 %/K 0.00 ... 20.00 %/K		This value is determined by the calibration solution.
	C133	Enter correct conductivity value of calibration solution	Current measured value 0.0 ... 9999 mS/cm		The practicable range is depends on the sensor, i.e. the calibration solution should be approx. 40 % of the measuring range determined by the cell (see chapter 9, Fig. 9.1). This display unit is always in mS/cm.
	C134	Calculated installation factor is displayed	1 0.10 ... 5.00		
	C135	Calibration status is displayed	o.k. E xxx		If the calibration status is not o.k., an explanation of the error is displayed in the second line of the display.
	C136	Store calibration result	yes no new		If C135 = E xxx, then only no or new . If new, return to C. If yes/no, return to "Measurement".

Factory settings are printed in **bold** face;
base version does not include functions in *italic*.



6 Interfaces

For instruments equipped with a communication interface, please refer to separate operating instructions BA 208C/07/en (HART®) or BA 209C/07/en (PROFIBUS®).

7 Maintenance and troubleshooting

Maintenance:

Please take all measures in due time which will guarantee the safety of operation and reliability of the entire measuring device.

Maintenance of CLM 223 / 253 comprises:

- Calibration (see chapter 5.11)
- Cleaning of assembly and sensor
- Checking of cables and connections

Troubleshooting:

Determination and elimination of the cause of the problem in the case of an operating fault. Troubleshooting refers to measures that can be performed without intervention in the instrument (for instrument defects, see chapter 8, Corrective maintenance).

Troubleshooting of the CLM 223/253 and the measuring system is performed with the aid of the troubleshooting table in chapter 7.1.



Warning:

- Please be aware of effects work performed on the instrument might have on the process control system or the process itself.
- When removing the sensor during maintenance or calibration, please consider potential hazards due to pressure, high temperatures and contamination.



Note:

- Please contact your E+H support office if you have any queries. You also send your queries to the E+H Service Organization via the Internet.

www.endress.com

7.1 Troubleshooting common problems

Error	Possible cause	Remedy	Equipment needed, spare parts
Instrument cannot be operated, value 9999	– Operation locked	Press CAL and MINUS key simultaneously	See chap. 4.3
Incorrect display compared with comparison measurement	– Device incorrectly calibrated	Calibrate device acc. to chap. 4.8	Calibration solution or sensor certificate
	– Sensor soiled	Clean sensor	See chap. 8.8.1
	– Temperature measurement incorrect	Check temperature value for measuring device and comparison device	Temperature measurement device, Thermometer
	– Temperature compensation incorrect	Check compensation method (no / ATC / MTC) and compensation type (linear / material / own table)	Please note: the Liquisys has a separate setting for a calibration temperature coefficient.
	– Comparison measurement is incorrectly calibrated	Calibrate comparison measuring device or use checked device.	Calibration solution, operating manual of comparison device
	– Comparison device has incorrectly set ATC	Compensation method and type must be identical for both devices.	Operating manual of comparison device
	– Polarisation error	Use suitable sensor: – Use larger cell constant – Use graphite instead of stainless steel (check resistance)	Measuring range tables e.g. in SI "Conductivity" or technical data of conductivity sensors
	– Incorrect line resistance in field A6	Enter correct value	For determination of line resistance see chap. 3.5

Error	Possible cause	Remedy	Equipment needed, spare parts
Implausible measured values in general: – Constant measured flow overflow – Constant measured value 000 – Measured value too low – Measured value too high – Measured value frozen – Current output value incorrect	– Short in sensor – Short in cable or junction box – Interruption in sensor – Interruption in cable or junction box – Cell constant incorrectly set – Incorrect output assignment – Incorrect output function – Air cushion in assembly – Grounding short on or in device – Transmitter module defective – Impermissible instrument operating state (no response to key actuation)	Check sensor Check cable and junction box Check sensor Check cable and junction box Check cell constants Check current assignment Check preselection 0–20 / 4–20 mA Check assembly and installation Measure in insulated container Simulation directly at instrument Switch instrument off and back on	see chap. 8.8.4 / 8.8.5 see chap. 8.8.2 / 8.8.3 see chap. 8.8.4 / 8.8.5 see chap. 8.8.2 / 8.8.3 Sensor nameplate or certificate Plastic container, calibration solutions For diagnosis and spare parts see chap. 8 EMV problem: if problem persists, check grounding and cable run
Incorrect temperature value	– Sensor connection incorrect – Measuring cable defective – Incorrect sensor type	Check connections using wiring diagram; Three-line connection always required Check cable for interruption / short circuit / shunt Set type of temperature sensor on device (Field B1)	Connection diagram chap. 3.4 Ohm meter; see also chap. 8.8.2 / 8.8.3
Cond. measured value incorrect in process	– No / incorrect temperature compensation – Incorrect temperature measurement – Bubbles in medium – Polarisation effects (only with conductive sensors) – Flow too high (can lead to bubble formations) – Voltage potential in medium (only when conductive) – Sensor soiled or coated – Incorrect line resistance in field A6	ATC: Select compensation type, if linear, set suitable coefficients. MTC: Set process temperature Check temperature value Suppress bubble formation – Gas bubble trap – Back-pressure creation (orifice plate) – Measurement in bypass Use suitable sensor: – Use larger cell constant – Use graphite instead of stainless steel (check resistance) Reduce flow rate or select installation location with less turbulence Ground sensor as near to medium as possible Clean sensor (see chap. 8.6.2) Enter correct value	Ref. measuring device / thermometer Measuring range tables e.g. in SI "Conductivity" or technical data of conductivity sensors Problem occurs primarily in plastic lines and tanks For contaminated media: Use spray cleaning For determination of line resistance see chap. 3.5
Measured value variations	– Faults on measuring cable – Faults on signal output line – Fault potential in medium	Connect cable screening according to wiring diagram Check line routine, if necessary route line separately Remove source of fault or ground medium as near as possible to cond. sensor	See chap. 3.5 Lines signal output, isolate measuring input and power supply
Controller or time cannot be activated	– No relay module available	Install module LSR1-2 or LSR1-4	See chap. 8.2 and 8.3
Controller / limit contact not working	– Controller switched off – Controller in "Manual / Off" mode – Pickup delay setting too long – Function "Hold" active	Activate controller Choose "Auto" or "Manual / On" mode Disable or shorten pickup delay "Auto Hold" during by calibration, "Hold" input activated; "Hold" via keypad active	See chap. 5.5 or fields R2xx Keypad REL key See fields R2xx See fields S2 to S4

Error	Possible cause	Remedy	Equipment needed, spare parts
Controller / limit contacts work continuously	<ul style="list-style-type: none"> – Controller in "Manual / On" mode – Dropout delay setting too long – Control loop interruption 	Set controller to "Manual / Off" or "Auto" Shorten dropout delay Check measured value, current output value, actuators, chemical supply	Keypad, REL and AUTO keys See fields R2xx
No conductivity current output signal	<ul style="list-style-type: none"> – Line open or short-circuited – Output defective 	Disconnect line and measure directly on instrument See chap. 8.1	mA meter 0–20 mA
Fixed current output signal	<ul style="list-style-type: none"> – Current simulation active – Processor system out of snyc 	Switch off simulation Switch instrument off and back on	See field O2 EMV problem: if problem persists, check installation
Incorrect current output signal	<ul style="list-style-type: none"> – Incorrect current assignment – Total load in current loop excessive (> 500 Ω) 	Check current assignment: 0–20 mA oder 4–20 mA? Disconnect output and measure directly on instrument	Field O211 mA meter for 0–20 mA DC
Current output table not accepted	<ul style="list-style-type: none"> – Value interval too small 	Use sensible intervals	
No temperature output signal	<ul style="list-style-type: none"> – Instrument has only one current output – Device with PROFIBUS-PA-/DP 	Check variant using nameplate, if necessary replace module LSCH-x1 PA-/DP devices have no current output.	Module LSCH-x2, see chap. 8.2.4 and 8.3.4
Chemoclean function not available	<ul style="list-style-type: none"> – No relay module (LSR1-x) installed or only LSR1-2 available or Chemoclean release code not entered (handling as with Plus packet, see next line) 	Install module LSR1-4. Chemoclean is released with release code. With Chemoclean upgrade: Code received from E+H ⇒ enter	Module LSR1-4, see chap. 8.2.4 and 8.3.4
Plus Package functions not available	<ul style="list-style-type: none"> – Plus package not enabled (enable with code that depends on serial number and is received from E+H with order of Plus package) 	<ul style="list-style-type: none"> – Plus package upgrade: code received from E+H ⇒ enter – Following replacement of defective LSCH/LSCP module: First enter instrument serial number (see nameplate) manually, then enter code number. 	Detailed description see chap. 8.3.5
No HART communication	<ul style="list-style-type: none"> – No central HART module – No or wrong DD (device description) – HART interface missing – Instrument not registered with HART server – Load too low (load > 230 Ω required) – HART receiver (e.g. FXA 191) not connected via load – Incorrect instrument address (Addr. = 0 for single operation, Addr. > 0 for multi-drop operation) – Line capacitance too high – Line interference 	Verify by looking at nameplate: HART = -xxx5xx und -xxx6xx For further information, see additional Operating Instructions BA 208C, "HART® – Field communication with Liquisys M CxM 223 / 253"	Upgrade to LSCH-H1 / -H2

Error	Possible cause	Remedy	Equipment needed, spare parts
No PROFIBUS communication	<ul style="list-style-type: none"> - No central PA-/DP module - Wrong SW version (without PROFIBUS) - with Commuwin (CW) II: CW II version and instrument SW version incompatible - No or wrong DD/DLL - Incorrect baud rate setting for segment coupler in DPV-1 server - Incorrect station (master) addressed or duplicate address - Incorrect station (slaves) address - Bus line not terminated - Line problems (too long, cross section too small; not shielded, screen not grounded, wires not twisted) - Bus voltage too low (bus supply voltage typ. 24 V DC for non-Ex, 13,5 V DC for Ex) 	<p>Verify by looking at nameplate: PA = -xxx3xx / DP = -xxx4xx</p> <p>For further information, see additional Operating Instructions BA 209C, "PROFIBUS-PA/-DP – Field communication with Liquisys M CxM 223 / 253"</p> <p>Voltage at instrument PA/DP connector must be at least 9 V.</p>	Upgrade to LSCP module
No HART or PROFIBUS communication	<ul style="list-style-type: none"> - Several instruments on the same address 	Check addresses and reset if necessary	

7.2 Troubleshooting using the error messages

Display and select error messages by pressing the MINUS key.

Error no.	Cause	Measures	Contact		Error current		Automatic cleaning trigger	
			Fact	User	Fact	User	Fact	User
E001	EEPROM memory error	Switch instrument off and back on, return instrument to your local Endress+Hauser sales agency for repair or replace instrument.	yes		no		—	—*
E002	Instrument not calibrated, calibration data invalid, no user data available or user data invalid (EEPROM error). Instrument software not suitable for hardware (Controller)	Load software compatible with hardware. Load measuring parameter specific instrument software.	yes		no		—	—*
E003	Download error	Invalid configuration. Repeat download, check optoscope.	yes		no		—	—*
E004	Instrument software version not compatible with module hardware version	Load software compatible with hardware. Load measuring parameter specific instrument software.	yes		no		—	—*
E007	Transmitter malfunction Software not compatible with hardware (transmitter)		yes		no		—	—*
E008	Sensor or sensor connection faulty	Check sensor and sensor connection (E+H Service).	yes		no		no	
E010	No temperature sensor connected or temperature sensor short-circuited	Check temperature sensor and connections; if necessary, check instrument with temperature simulator.	yes		no		no	
E025	Limit for Airset offset exceeded	Repeat Airset (in air) or replace sensor. Dry cell.	yes		no		no	
E036	Calibration range of sensor exceeded	Clean sensor and recalibrate; if necessary, check sensor and connections.	yes		no		no	
E037	Below calibration range of sensor		yes		no		no	
E045	Calibration aborted	Recalibrate.	yes		no		—	—*
E049	Calibration range of installation factor exceeded	Check pipe diameter, clean sensor and recalibrate.	yes		no		—	—*
E050	Below calibration range of installation factor	Check pipe diameter, clean sensor and recalibrate.	yes		no		—	—*
E055	Below measuring range of main parameter	Immerse sensor in conductive medium or perform Airset.	yes		no		no	
E057	Measuring range of main parameter exceeded	Check measurement, control and connections.	yes		no		no	
E059	Below temperature measuring range		yes		no		no	
E061	Temperature measuring range exceeded		yes		no		no	
E063	Below current output range 1	Check configuration.	yes		no		no	
E064	Current output range 1 exceeded	Check measured value and current assignment.	yes		no		no	
E065	Below current output range 2		yes		no		no	
E066	Current output range 2 exceeded	Check measured value and current assignment.	yes		no		no	

Error no.	Cause	Measures	Contact		Error current		Automatic cleaning trigger	
			Fact	User	Fact	User	Fact	User
E067	Alarm threshold limit contactor 1 exceeded	Check configuration.	yes		no		no	
E068	Alarm threshold limit contactor 2 exceeded		yes		no		no	
E069	Alarm threshold limit contactor 3 exceeded		yes		no		no	
E070	Alarm threshold limit contactor 4 exceeded		yes		no		no	
E071	Inaccurate measurement/polarisation	Clean sensor; check table; choose suitable sensor	yes		no		no	
E077	Temperature outside α value table range	Clean sensor; check table.	yes		no		no	
E078	Temperature outside concentration table		yes		no		no	
E079	Conductivity outside concentration table		yes		no		no	
E080	Current output 1 parameter range too small	Spread current output.	no		no		—	—*
E081	Current output 2 parameter range too small	Spread current output.	no		no		—	—*
E100	Current simulation active		no		no		—	—*
E101	Service function yes	Switch service function off or switch instrument off and back on.	no		no		—	—*
E102	Manual mode active		no		no		—	—*
E106	Download yes	Wait for download to end.	no		no		—	—*
E116	Download error	Repeat download.	no		no		—	—*
E150	Distance between temp. values in α value table too small or not monotonically increasing	Enter correct values in α value table (minimum distance between temperature values of 1 K required).	no		no		no	
E151	USP error		no		no		no	
E152	PCS alarm	Check sensor sensor connection.	no		no		no	
E153	USP temperature error		no		no		no	
E154	Below lower alarm threshold for period exceeding alarm delay	If necessary perform manual reference measurement. Repair sensor and recalibrate.	yes		no		no	
E155	Lower alarm threshold exceeded for period exceeding alarm delay		yes		no		no	
E156	Actual value undershoots set point for longer than the set permissible maximum period		yes		no		no	
E157	Actual value exceeds set point for longer than the set permissible maximum period		yes		no		no	

When this error is present, the cleaning function cannot be started.
(Field F8 does not exist for this error.)

8 Diagnosis and corrective maintenance

Diagnosis:

- Diagnosis refers to the identification of instrument malfunctions and defects.

Corrective maintenance:

- replacement of parts diagnosed to be defective;
- testing of instrument and measuring system function;
- restoration of complete functionality.

Diagnosis based on the error table below and depending on difficulty and measuring equipment at hand is to be performed by:

- trained operator personnel
- operator's electricians
- company responsible for system installation/ operation
- E+H Service.

Select the required spare parts using the tables in chapter 8.2 and 8.3.



Warning:

- Disconnect the instrument from the power source before opening it up. Work with live lines may only be performed by trained electricians.
- Switching contacts may be supplied from separate circuits. These circuits must also be de-energised before work on the terminals is performed.



Caution: ESD!

- Electronic components are sensitive to electrostatic discharges. Personal protective measures, such as discharge via PE or permanent grounding using a wrist strap, are to be taken.
- For your own safety, use only original spare parts. Original parts will guarantee functionality, accuracy and reliability after repairs.

8.1 Diagnosis

The table below will help you diagnose problems and provides information about spare parts required. You can find information concerning the exact spare part designations and the installation of these parts in chapters 8.2.3 and 8.3.3.

Error	Possible cause	Tests and / or remedial measures	Equipment, spare parts, personnel
Display dark, no LEDs active	<ul style="list-style-type: none"> – No mains voltage – Incorrect supply voltage / voltage too low – Connection fault – Device fuse defective – Power unit defective – Controller defective – CLM 253: Ribbon cable Pos. 310 loose or defective Replace ribbon cable if necessary 	<ul style="list-style-type: none"> Check if mains voltage is available Compare mains voltage and rating on nameplate Terminal not tightened; insulation clamped in terminal; incorrect terminal used Replace fuse, also compare mains voltage and nameplate data Replace power unit, pay close attention to versions Replace controller, note versions especially see CLM 253 spare parts 	<ul style="list-style-type: none"> Electrician / e.g. multimeter Operator (utility company specification or multimeter) Electrician Electrician / suitable fuse; s. Figs. 8.2.1 and 8.3.1 Diagnosis by E+H Service on-site (test module required) Diagnosis by E+H Service on-site (test module required)
Display dark, but LED(s) active	<ul style="list-style-type: none"> – Controller defective (Module: LSCH/LSCP) 	<ul style="list-style-type: none"> Replace controller 	<ul style="list-style-type: none"> Diagnosis by E+H Service on-site (test module required)



Error	Possible cause	Tests and / or remedial measures	Equipment, spare parts, personnel
Display working, but – no change in the display and / or – device cannot be operated	– Device or module in the device incorrectly mounted – Impermissible operating system state	CLM 223: Re-install plug-in module CLM 253: Remount display module Switch device off and back on	Implementation with the help of the assembly drawings chapter 8.2.1 and 8.3.1 Possible EMC problem: if problem persists, call E+H Service to have installation checked
Device gets hot	– Voltage incorrect / too high – Power supply unit defective	Compare mains voltage and nameplate data Replace power supply unit	Can only be diagnosed by E+H Service
Incorrect meas. Cond./MΩ and/or temperature	– Transmitter module defective (Module: MKIC), please perform tests and take measures according to chap. 7.1	Testing the measurement inputs: – connect resistor in place of conductivity sensor, see table chapter 8.8.1 – Resistance 100 Ω to terminals 11/12 + 13 = Display 0 °C	If test negative: 8.4.1 and 8.5.1. 8.2.1 and 8.3.1
Current output, current value incorrect	– Calibration incorrect – Load excessive – Shunt / short-circuit to frame in current loop – Incorrect operating mode	Check with built-in current simulation, connect mA meter directly to current output Check whether 0–20 mA or 4–20 mA has been selected	If simulation value incorrect: recalibration at factory or new LSCxx module required. If simulation value is correct: Check current loop for load and shunts.
No current output signal	– Current output stage defective (module: LSCH/LSCP)	Check with built-in current simulation, connect mA meter direct to the current output	If test negative: Replace controller (using correct variant)
Additional relay does not function	– CLM 253: Ribbon cable Pos. 320 loose or defective	Check ribbon cable base, if necessary replace cable	See Spare parts COM 253 F Replace cable
Only 2 additional relays accessible	– Relay module LSR1-2 with 2 relays built-in	Upgrade to LSR1-4 with 4 relays	User, E+H Service
Enhanced functions (Plus package) not available	– No or incorrect release code used – Incorrect serial number of the LSCH-/LSCP module	If upgraded: verify that correct serial number has been used to order the Plus package. Check whether serial number on the nameplate corresponds to SNR LSCH/LSCP (field S8).	Handled by E+H Sales The LSCH/LSCP module serial number is required to enable the Plus package .
Enhanced functions (Plus package and/or Chemoclean) are not available after replacement of LSCH/LSCP module	– Plus-package or Chemoclean has not been enabled with release codes	For brand new LSCH / LSCP with SNR you can enter a device serial number once in fields E115 to E117. Then, if necessary, enter release codes for Plus packet and / or Chemoclean.	A detailed description can be found in chapter 8.3.5
No HART or PROFIBUS interface function	– Wrong central module – Incorrect software – Bus problem	HART: LSCH-H1 or -H2 PROFIBUS-PA/-DP: LSCP-PA/-DP module, see field E112 Device software see field E111 Remove some devices and repeat testing	Replace central module; operator or E+H Service Contact E+H Service for support

8.2 Corrective maintenance of Liquisys M CLM 223

8.2.1 Exploded view

223_EXLF.CDR

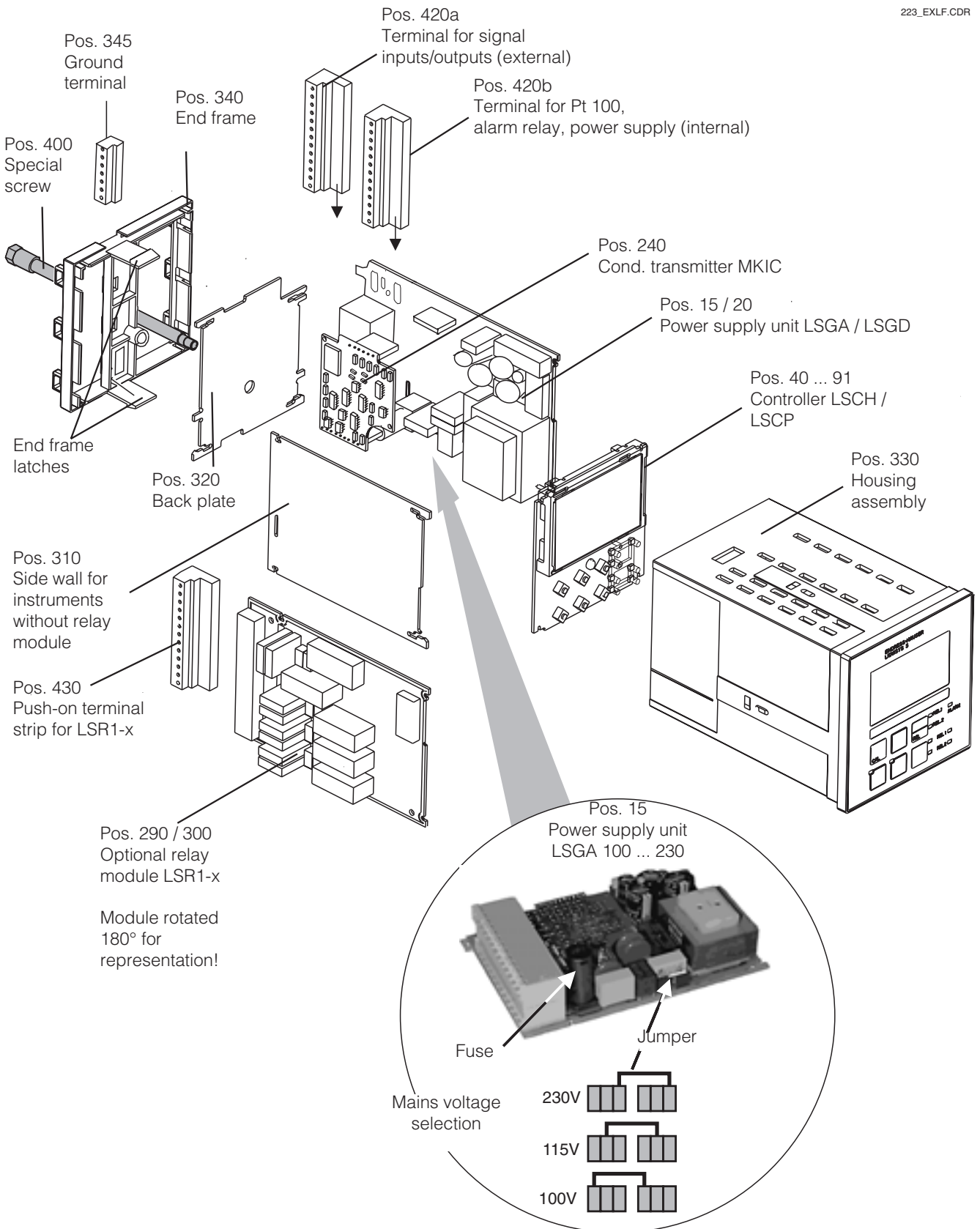



8.2.2 Disassembly of CLM 223

- Consider potential effects on process when removing the instrument from service!
- First pull off the terminal block (Pos. 420b) on the rear side of the device, to make the device voltage-free.
- First pull off the terminal blocks (Pos. 420a and if necessary 430) on the rear of the instrument. You can now remove the instrument.
- Press the latches of the end frame (Pos. 340) inwards and pull off the frame towards the rear.
- Loosen the special screw (Pos. 400) by turning it counterclockwise.
- Remove the complete electronics block from the housing. The modules are plugged together mechanically and can be easily separated:
 - Simply pull the central/ LCD module to the front.
 - Gently pull the flaps of the backplane outwards, to remove the side modules.

8.2.3 Assembly of CLM 223

- Reverse the dismantling sequence for assembly.
- Hand-tighten the special screw without using a tool.
- Incorrect assembly is not possible!
A module block which has been plugged together incorrectly cannot be inserted in the housing.



8.2.4 Spare parts for CLM 223

Pos.	Designation	Name	Function	Order number
15	Power supply unit	LSGA	100/115/230 V AC	51500317
20	Power supply unit	LSGD	24 V AC + DC	51500318
290	Relay module	LSR1-2	2 relays	51500320
300	Relay module	LSR1-4	4 relays	51500321
40	Controller conductive	LSCH-S1	1 current output	51501210
50	Controller conductive	LSCH-S2	2 current outputs	51501212
60	Controller conductive	LSCH-H1	1 current output + HART	51501213
70	Controller conductive	LSCH-H2	2 current outputs + HART	51501214
80	Controller conductive	LSCP-PA	PROFIBUS-PA / no current output.	51501215
90	Controller conductive	LSCP-DP	PROFIBUS-DP / no current output.	51502502
41	Controller inductive	LSCH-S1	1 current output	51501216
51	Controller inductive	LSCH-S2	2 current outputs	51501218
61	Controller inductive	LSCH-H1	1 current output + HART	51501219
71	Controller inductive	LSCH-H2	2 current output + HART	51501220
81	Controller inductive	LSCP-PA	PROFIBUS-PA / no current output.	51501221
91	Controller inductive	LSCP-DP	PROFIBUS-DP / no current output.	51502501
240	Cond. transmitter	MKIC	Cond. + temperature input	51501206
310	Side panel		Kit with 10 side panels	51502124
340	End frame PROFIBUS-DP		End frame with D-Submin plug-in connector	51502513
330, 340	Housing module		With front membrane, plunger- operated probes, seal, special screw, clamping tappets, all signs	51501075
310, 320, 340, 400	Mechanical parts Housing		Backplate, side wall, end frame, special screw	51501076
420a, 420b	Complete terminal strip set, Standard + HART		Terminal strip set Standard + HART, inputs/outputs, power supply, alarm relay	51501203
420a, 420b	Complete terminal strip set, PROFIBUS-PA		Terminal strip set PROFIBUS-PA, inputs/outputs, power supply, alarm relay	51502126
420a, 420b	Complete terminal strip set, PROFIBUS-DP		Terminal strip set PROFIBUS-DP, inputs/outputs, power supply, alarm relay	51502493
430	Terminal strip		Terminal strip for relay module	51501078
345	Grounding terminal strip		PE and screening connections	51501086

8.3 Corrective maintenance of Liquisys M CLM 253

8.3.1 Exploded view

253_EXLF.CDR

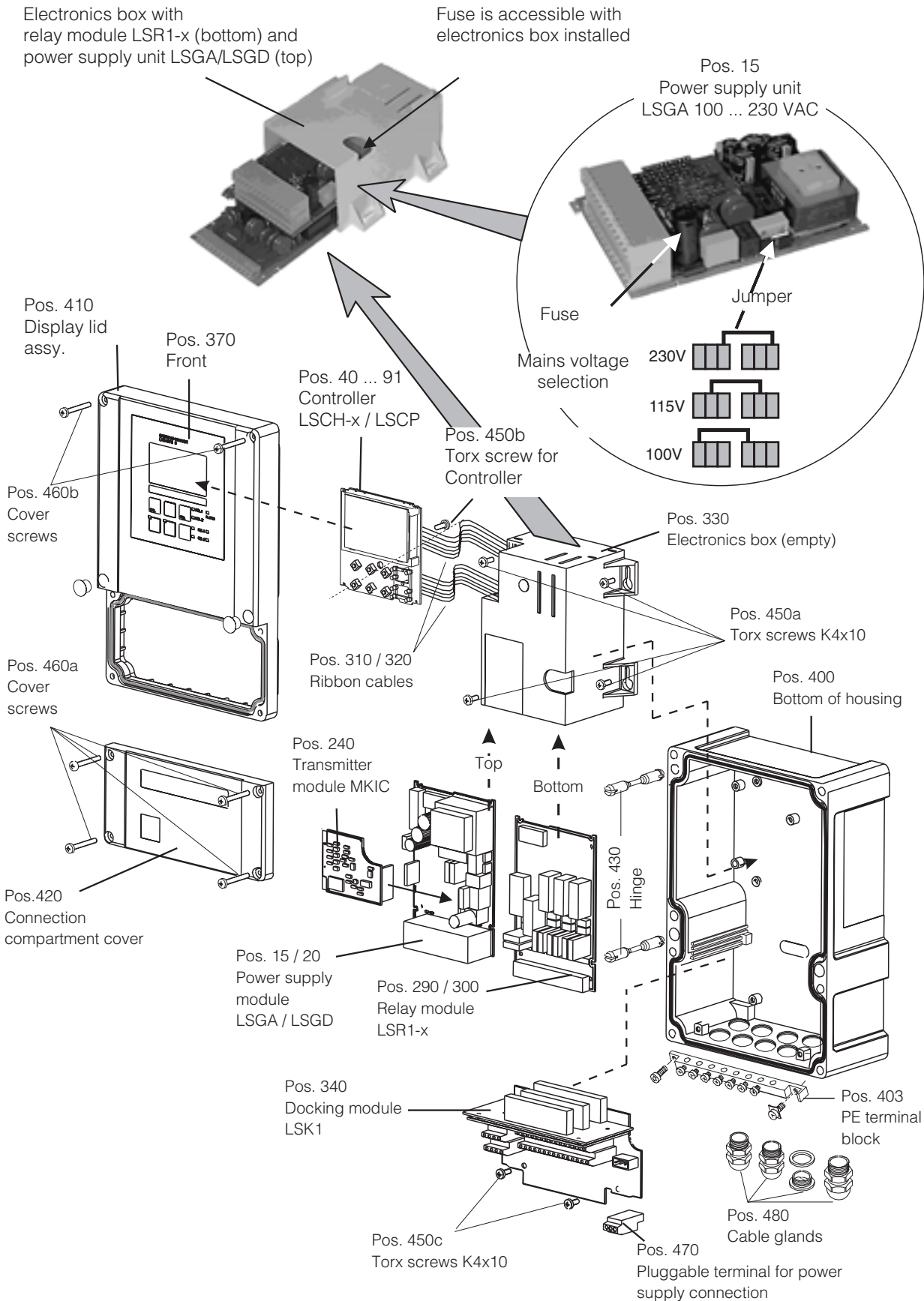



8.3.2 Disassembly of CLM 253

- Open and remove the connection compartment cover (Pos. 420).
- Pull out the mains terminal (Pos. 470) to make the device voltage-free.
- Open the display cover (Pos. 410) and loosen the ribbon cable (Pos. 310 / 320) on the electronics box (Pos. 330).
- Dismantling the controller (Pos. 40):
Loosen screw (Pos. 450b) in the display lid.
- Removal of electronics box (Pos. 330):
Loosen screws (Pos. 450a) in the bottom of the housing 2 revolutions, then slide entire box backward and remove towards the top. Make absolutely sure that the module locks do not open!
- Now bend the module latches outward and remove the module(s).
- Dismantling the docking module (Pos. 340):
Loosen screws (Pos. 450c) in the bottom of the housing and remove entire module towards the top.

8.3.3 Assembly of CLM 253

- Insert the module(s) in the electronics box guide rails carefully and latch into the lateral lugs in the box.
- Incorrect assembly is not possible!
Modules inserted in the electronics box incorrectly are not operable since the ribbon cables cannot be inserted.
- Make sure that the cover gaskets are intact since they are required to guarantee protection class IP 65.

8.3.4 Spare parts for CLM 253

Pos.	Designation	Name	Function	Order number
15	Power supply unit	LSGA	100/115/230 V AC	51500317
20	Power supply unit	LSGD	24 V AC + DC	51500318
290	Relay module	LSR1-2	2 relays	51500320
300	Relay module	LSR1-4	4 relays	51500321
40	Controller conductive	LSCH-S1	1 current output	51501210
50	Controller conductive	LSCH-S2	2 current outputs	51501212
60	Controller conductive	LSCH-H1	1 current output + HART	51501213
70	Controller conductive	LSCH-H2	2 current outputs + HART	51501214
80	Controller conductive	LSCP-PA	PROFIBUS-PA / no current output.	51501215
90	Controller conductive	LSCP-DP	PROFIBUS-DP / no current output.	51502502
41	Controller inductive	LSCH-S1	1 current output	51501216
51	Controller inductive	LSCH-S2	2 current outputs	51501218
61	Controller inductive	LSCH-H1	1 current output + HART	51501219
71	Controller inductive	LSCH-H2	2 current outputs + HART	51501220
81	Controller inductive	LSCP-PA	PROFIBUS-PA / no current output.	51501221
91	Controller inductive	LSCP-DP	PROFIBUS-DP / no current output.	51502501
240	Cond. transmitter	MKIC	Cond. + temperature input	51501206
370, 410, 420, 430	Housing cover assy.		Display cover, connection compartment cover, front membrane, hinge	51501068
400, 480	Lower housing section (mechanics)		Lower section, screw union	51501072
330, 340, 450	Internal housing parts		Docking assembly, empty electronics box, small parts	51501073
310, 320	Ribbon cables		2 ribbon cables	51501074
430	Hinges		2 pairs of hinges	51501069
470	Power supply terminal strip		Terminal strip 2-pin	51501079
403	PE terminal block		PE and screening connections	51501087

8.3.5 Special case: replacement of central module



Note:

- After controller replacement all the editable data are reset to the factory settings.
- The serial number can only be entered – and **only once** – in the case of a new module from the factory with serial number 0000! Make sure that your entry is correct before confirming with ENTER! Entry of an incorrect code will prevent the enhanced functions from being enabled. An incorrect serial number can only be corrected at the factory.

Proceed as described below after central module replacement:

- If possible, record the user settings of the instrument, e.g.:
 - Calibration data
 - Current assignment cond./MΩ and temperature
 - Relay function selections
 - Limit / controller settings
 - Cleaning settings
 - Monitoring functions
 - Interface parameters

- Dismantle the instrument as described in chap. 8.2.2 or 8.3.2.
- Refer to the part no. of the central module to determine whether the new module has the same part no. as the old one.
- Reassemble the instrument with the new module, as described in chap. 8.2.3 or 8.3.3.
- Start up the instrument and test its basic functions (e.g. meas. value and temperature display, operation via keyboard).
- Enter the instrument serial number:
 - Read the serial number (»ser-no.«) of the instrument from the nameplate.
 - Enter this number in the fields E115 (year), E116 (month), E117 (sequence number, four-digit).
 - Field E118 displays the complete number for verification; acknowledge with ENTER or abort and re-enter.
- Verify that the Plus package is enabled (e.g. by accessing function group CHECK / Code P) or the Chemoclean function.
- Check the Plus package release (e.g. by opening the function group CHECK / Code P) or the Chemoclean function.
- Restore the user settings of the instrument.

8.4 Spare parts orders

Spare parts are to be ordered from your local E+H Sales Agency. The address is on the back cover of these operating instructions. Use the order numbers listed in chapters 8.2.4 or 8.3.4.

To be on the safe side, you should **always** specify the following data with spare parts orders:

- Instrument order code (order code)
- Serial number (ser-no.)
- Software version where available

Refer to the nameplate for the order code and serial number. The software version is displayed in field E111 when the instrument processor system is functional.

8.5 Service equipment “Optoscope” with “Scopeware”

The Optoscope together with the “Scopeware” software offers the following possibilities, **without** having to remove or open the Liquisys M and **without** galvanic connection to the instrument:

- Documentation of the instrument settings in conjunction with Commuwin II Software update by the service technician
- Upload/download a hex dump to duplicate configurations.

Handling and operation are described in the optoscope operating instructions. The user-friendly Windows software required for the PC or laptop is supplied with the optoscope.

The optoscope is supplied in a sturdy case with all the accessories required.

Order number of optoscope: 51500650

The optoscope serves as an interface between the Liquisys M and PC / laptop. The information exchange takes place via the optical interface on the Liquisys M and via an RS 232 interface on the PC / laptop.

8.6 Corrective maintenance of measuring system

8.6.1 Conductivity transmitter

Cleaning the front panel

To clean the front panel, only use standard cleaning agents.

The front panel is resistant to the following cleaning agents (nach Testmethode DIN 42 115):

- Isopropanol
- Thinned acids (3 %)
- Thinned alkalis (5 %)
- Ester
- Hydrocarbons
- Ketone
- Household cleaners



Caution!

Do not use any concentrated mineral acids or alkalis, benzyl-alcohol, methylene chloride or high-pressure water vapour at over 100 °C.

8.6.2 Conductivity sensors

Clean recognisable **soilings on the conductivity sensors** as follows:

- Clean *oil and greasy coatings* with detergent (grease remover, alcohol or washing-up liquid).



Warning:

Hands, eyes and clothes are to be protected when using the cleaning agents described below.

- *Lime and metal hydroxide coatings*
Dissolve coatings with diluted hydrochloric acid (3%) and then rinse carefully.
- *With sulphurous coatings (from REA or sewage treatment works)*
Use a mixture of hydrochloric acid (0.5 %) and thiocarbamide (8 %), and then rinse carefully.
- *Coatings containing proteins (food industry)*
Use a mixture of hydrochloric acid (0.5 %) and pepsin (1 %), and then rinse carefully.

8.6.3 Simulation of conductive sensors for device test

Check a measuring device for conductivity by replacing the measuring section and temperature sensor with resistors. Simulation accuracy is dependent on the accuracy of the resistors.

For conductivity, the values in the right-hand table are valid, if the cell constant k is set to the nominal value according to column 2. Otherwise: Display $\text{cond.}_{[\text{mS/cm}]} = k \cdot 1/R_{[\text{k}\Omega]}$.

The values in the following table are valid for temperature, if no temperature offset is set on Liquisys M.

Also connect the temperature equivalent resistor in a three-line system.

- To connect decade resistors instead of the conductivity sensor to the plug of a conductivity measuring cable, you can use the "Conductivity Test Adapter" service kit.

Order number: 51500629.

Pt 100 replacement resistances:

Temperature	Resistance value
-20 °C	92,13 Ω
-10 °C	96,07 Ω
0 °C	100,00 Ω
10 °C	103,90 Ω
20 °C	107,79 Ω
25 °C	109,73 Ω
50 °C	119,40 Ω
80 °C	130,89 Ω
100 °C	138,50 Ω
200 °C	175,84 Ω

With the temperature sensor type Pt 1000, all the resistance values are increased by a factor of 10 .

**Replacement resistances:**

Resistance R	Cell constant k	Display for conductivity	Display for $M\Omega$
10 Ω	1 cm^{-1}	100 mS/cm	
	10 cm^{-1}	1000 mS/cm	
100 Ω	0.1 cm^{-1}	1 mS/cm	1 $\text{k}\Omega \cdot \text{cm}$
	1 cm^{-1}	10 mS/cm	
	10 cm^{-1}	100 mS/cm	
1000 Ω	0.1 cm^{-1}	0.1 mS/cm	10 $\text{k}\Omega \cdot \text{cm}$
	1 cm^{-1}	1 mS/cm	
	10 cm^{-1}	10 mS/cm	
10 $\text{k}\Omega$	0.01 cm^{-1}	1 $\mu\text{S}/\text{cm}$	1 $\text{M}\Omega \cdot \text{cm}$
	0.1 cm^{-1}	10 $\mu\text{S}/\text{cm}$	100 $\text{k}\Omega \cdot \text{cm}$
	1 cm^{-1}	100 $\mu\text{S}/\text{cm}$	
	10 cm^{-1}	1 mS/cm	
100 $\text{k}\Omega$	0.01 cm^{-1}	0.1 mS/cm	10 $\text{M}\Omega \cdot \text{cm}$
	0.1 cm^{-1}	1 $\mu\text{S}/\text{cm}$	1 $\text{M}\Omega \cdot \text{cm}$
	1 cm^{-1}	10 $\mu\text{S}/\text{cm}$	
1 $\text{M}\Omega$	0.01 cm^{-1}	0.01 $\mu\text{S}/\text{cm}$	100 $\text{M}\Omega \cdot \text{cm}$
	0.1 cm^{-1}	0.1 $\mu\text{S}/\text{cm}$	10 $\text{M}\Omega \cdot \text{cm}$
	1 cm^{-1}	1 $\mu\text{S}/\text{cm}$	
10 $\text{M}\Omega$	0.01 cm^{-1}	0.001 $\mu\text{S}/\text{cm}$	
	0.1 cm^{-1}	0.01 $\mu\text{S}/\text{cm}$	100 $\text{M}\Omega \cdot \text{cm}$

**Note:**

The $M\Omega$ measurement is normally used for pure and ultrapure water and therefore is only wise for cell constants where $k = 0.01$ or poss. $k = 0.1$.

8.6.4 Simulation of inductive conductivity sensors for device test

An inductive sensor can not be formed by resistors.

However, it is possible to check the complete system CLM 2x3-ID including the inductive sensor using replacement resistances. Note the cell constant k (e.g. $k_{\text{nominal}} = 2$ for CLS 50, $k_{\text{nominal}} = 5.9$ for CLS 52).

For an accurate simulation, you must use the cell constant actually used (readable in Field C124) for the calculation of the display value: $\text{Display cond.}_{[\text{mS/cm}]} = k \cdot 1/R_{[\text{k}\Omega]}$.

Guide values for the simulation CLS 50 at 25 °C:

Simulation resistance R	Cell constant k	Display cond.
2 Ω	2.00 cm^{-1}	1000 mS/cm
10 Ω	2.00 cm^{-1}	200 mS/cm
100 Ω	2.00 cm^{-1}	20 mS/cm
1 k Ω	2.0 cm^{-1}	2 mS/cm

- Executing the simulation:
Pull a line through the sensor opening and then connect it to a decade resistor, for example.

8.6.5 Check of conductive conductivity sensors

- Measuring surface connection:
The measuring surfaces are directly connected to the connections of the sensor connector.
Check with ohmmeter at $< 1 \Omega$.
- Measuring surface shunt:
There may not be any shunt between the measuring surfaces.
Check with ohmmeter at $> 20 \text{ M}\Omega$.
- Temperature sensor shunt:
There may not be any shunt between the measuring surfaces and the temperature sensor.
Check with ohmmeter at $> 20 \text{ M}\Omega$.
- Temperature sensor:
You can discover the type of the temperature sensor being used by consulting the sensor nameplate.
The sensor can be checked at the sensor connector with an ohmmeter:
 - Pt 100 at 25 °C = 109.79 Ω
 - Pt 1000 at 25 °C = 1097.9 Ω
 - NTC 10 k at 25 °C = 10 k Ω .
- Connection:
For sensors with a terminal connection (CLS 12/13) check the assignment of the terminals for reversals and the tightness of the terminal screws.

8.6.6 Check of inductive conductivity sensors

The following data is valid for the sensors CLS 50 and CLS 52.

- Test send coil and receive coil (Red and white coaxial cable, measure each between the inner connector and screen):
 - Ohmic resistance approx. 0.5 ... 2 Ω
 - Inductivity approx. 260 ... 450 mH (at 2 kHz).
- Test coil shunt:
There may be not shunt between the coils (from coax red to coax white).
Check with ohmmeter at $> 20 \text{ M}\Omega$.
- Temperature sensor test:
To test the Pt 100, use the table in chap. 8.6.4.
The resistance values between the green and white wires and the green and yellow wires must be identical.
- Test temperature sensor shunt:
There may be no shunts between the temperature sensor (green, white or yellow lines) and the coils (red coaxial cable and white coaxial cable).
Check with ohmmeter at $> 20 \text{ M}\Omega$.

8.6.7 Connecting lines and junction boxes

- For a rapid and function check from the sensor connector (with conductive sensors) or from the sensor (with inductive sensors) to the measuring device, use the methods described in chap. 8.6.3 or 8.6.4. Connect the decade resistors simply with the service kit "Cond. Test Adapter" Order number: 51500629.
- Check the junction boxes for:
 - Humidity (influence at low conductivity or $\text{M}\Omega$ measurement, if necessary dry box, replace seals, insert dehydrating bag)
 - Correct connection of all lines
 - Connection of the outer screening
 - Tightness of the terminal screws.



9 Accessories

Mounting accessories

- Weather protection cover CYY 101
For mounting on field housing, for outdoor installation.
Dimensions (H × W × D):
320 × 300 × 270 mm
Material: Stainless steel SS 304
Order no.: CYY 101-A
- Universal upright post CYY 102
Square tube for mounting of field housing.
Dimensions (H × W × D):
1495 × 60 × 60 mm
Material: Stainless steel SS 304
Order no.: CYY 102-A

Sensors

- ConduMax W CLS 12
Conductive conductivity sensor
Technical Information TI 082C/07/en
Order no.: 50059349
- ConduMax W CLS 15
Conductive conductivity sensor
Technical Information TI 109C/07/en
Order no.: 50065950
- ConduMax W CLS 19
Conductive conductivity sensor
Technical Information TI 110C/07/en
Order no.: 50065951
- ConduMax W CLS 20
Conductive conductivity sensor
Technical Information TI 084C/07/en
Order no.: 50059351
- ConduMax W CLS 21
Conductive conductivity sensor
Technical Information TI 085C/07/en
Order no.: 50059352
- ConduMax W CLS 30
Conductive conductivity sensor
Technical Information TI 086C/07/en
Order no.: 50059353
- InduMax P CLS 50
Inductive conductivity sensor
Technical Information TI 182C/07/en
Order no.: 50090385
- InduMax H CLS 52
Inductive conductivity sensor
Technical Information TI 167C/07/en
Order no.: 50086110

Connection accessories

- Extension cable CLK 5
non-terminated measuring cable for inductive sensors (by the meter)
Order no.: 50085473
- Extension cable CYK 71
Non-terminated measuring cable for conductivity sensors (by the meter)
Order no.: 50085333
- Junction box VBM
Junction box for measuring cable extension between sensors and instrument. Pg 13.5 cable entries.
Material: cast aluminium;
Ingress protection: IP 65
Order no.: 50003987

Assemblies

DipFit W CLA 111
Immersion assembly for G1 and G $\frac{3}{4}$ conductivity sensors.
Technical Information TI 135C/07/en
Order no.: 50076858

Device upgrade

(Order only possible with serial number data of relevant instrument)

- Plus package
Order no.: 51500385
- Chemoclean
Order no.: 51500963
- Two-relay card
Order no.: 51500320
- Four-relay card
Order no.: 51500321

Accessories for CUM 253 CSA version

- NPT adapter set
Order no.:

Conductivity sensors

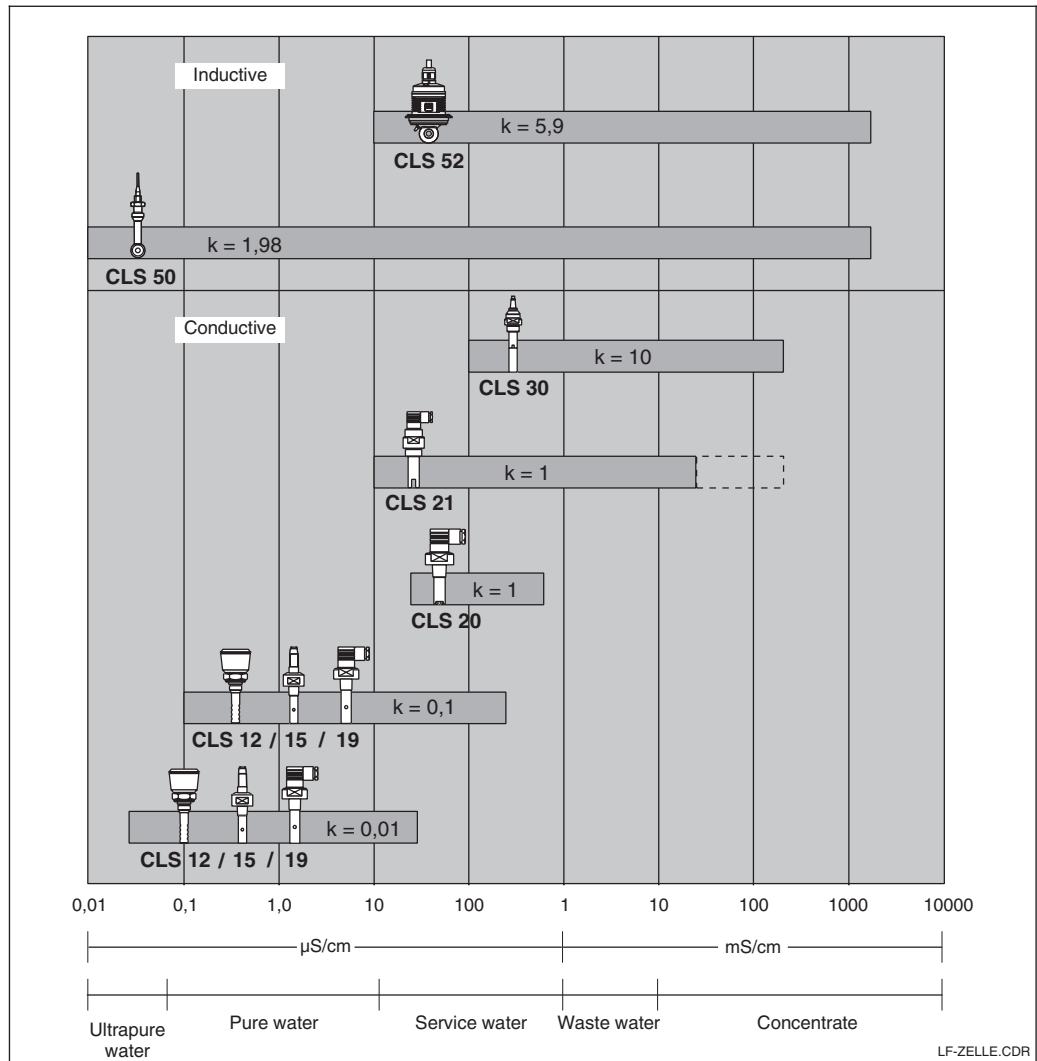

Fig. 9.1 Overview of the measuring ranges of E+H conductivity sensors

---- Limited accuracy

10 Technical data

General specifications

Manufacturer	Endress+Hauser
Device name	Liquisys M CLM 223 Liquisys M CLM 253

Input

Measuring parameters	Conductivity, resistance, concentration, temperature
----------------------	--

Min. spacing for 0 / 4 ... 20 mA signal

Conductivity measurement	Measured value 0 ... 19.99 $\mu\text{S}/\text{cm}$: 2 $\mu\text{S}/\text{cm}$ Measured value 20 ... 199.9 $\mu\text{S}/\text{cm}$: 20 $\mu\text{S}/\text{cm}$ Measured value 200 ... 1999 $\mu\text{S}/\text{cm}$: 200 $\mu\text{S}/\text{cm}$ Measured value 2 ... 19.99 mS/cm : 2 mS/cm Measured value 20 ... 2000 mS/cm : 20 mS/cm
Resistance measurement	Measured value 0 ... 199.9 $\text{k}\Omega \cdot \text{cm}$: 20 $\text{k}\Omega \cdot \text{cm}$ Measured value 200 ... 1999 $\text{k}\Omega \cdot \text{cm}$: 200 $\text{k}\Omega \cdot \text{cm}$ Measured value 2 ... 19.99 $\text{M}\Omega \cdot \text{cm}$: 2.0 $\text{M}\Omega \cdot \text{cm}$ Measured value 20 ... 200 $\text{M}\Omega \cdot \text{cm}$: 20 $\text{M}\Omega \cdot \text{cm}$
Concentration measurement	no minimum spacing

Conductive conductivity / resistance measurement

Measuring range	Conductivity: 0 ... 600 mS/cm (uncompensated) Resistance: 0 ... 200 $\text{M}\Omega \cdot \text{cm}$ Concentration: 0 ... 9999 %
Usable cell constant	$k = 0.0025 \dots 99.99 \text{ cm}^{-1}$
Maximum cable length to sensors	Conductivity: 100 m Resistance: 15 m
Line resistance of measuring cable CYK 71	$60 \Omega \cdot \text{km}^{-1}$
Required conductor cross-section	CLM 223 0.75 mm^2 / AWG 18 CLM 253 1.50 mm^2 / AWG 14
Terminal cross-section	2.5 mm^2
Measuring frequency	Conductivity: 170 ... 2000 Hz Resistance: 170 ... 2000 Hz

Inductive conductivity measurement

Measuring range	0 ... 2000 mS/cm (uncompensated)
Usable cell constant	$k = 0.0025 \dots 99.99 \text{ cm}^{-1}$
Maximum cable length to sensor	55 m (CLK 5)
Required conductor cross-section	CLM 223 0.75 mm^2 / AWG 18 CLM 253 1.50 mm^2 / AWG 14
Terminal cross-section	2.5 mm^2
Measuring frequency	2 kHz

Temperature measurement

Temperature sensor	Pt 100, Pt 1000, NTC
Measuring range	-35 ... +250 $^{\circ}\text{C}$
Temperature offset range	$\pm 5.0 \text{ }^{\circ}\text{C}$

Temperature compensation

Compensation types	linear, NaCl, table; only conductive: ultrapure water
Range	-35 ... +250 $^{\circ}\text{C}$
Reference temperature	25 $^{\circ}\text{C}$

Digital inputs 1 and 2

Voltage	10 ... 50 V
Current consumption	max. 10 mA

Output
Conductivity / resistance signal output

Current range	0 / 4 ... 20 mA, galvanically isolated; error current 2.4 / 22 mA
Load	max. 500 Ω
Maximum resolution	700 digits/mA
Output range	adjustable
Separation voltage	max. 350 V _{rms} / 500 V DC
Overvoltage (lightning) protection	acc. to EN 61000-4-5:1995

Temperature signal output (optional)

Current range	0 / 4 ... 20 mA, galvanically isolated
Load	max. 500 Ω
Maximum resolution	700 digits/mA
Output range	adjustable, Δ 10 ... Δ 100 % from measuring range end
Separation voltage	max. 350 V _{rms} / 500 V DC
Overvoltage (lightning) protection	acc. to EN 61000-4-5:1995

Auxiliary voltage output

Output voltage	15 V ± 0.6 V
Output current	max. 10 mA

Contact outputs (floating changeover contacts)

Switching current with ohmic load (cos φ = 1)	max. 2 A
Switching current with inductive load (cos φ = 0.4)	max. 2 A
Switching voltage	max. 250 V AC, 30 V DC
Switching power with ohmic load (cos φ = 1)	max. 500 VA AC, 60 W DC
Switching power with inductive load (cos φ = 0.4)	max. 500 VA AC, 60 W DC

Limit contactor

Pickup / dropout delay	0 ... 2000 s
------------------------	--------------

Controller

Function (adjustable)	Pulse length / pulse frequency controller
Controller response	P, PI, PD, PID
Controller gain K _p	0,01 ... 20,00
Integral action time T _n	0,0 ... 999,9 min
Derivative action time T _v	0,0 ... 999,9 min
Period for pulse length controller	0,5 ... 999,9 s
Frequency for pulse frequency controller	60 ... 180 min ⁻¹

Alarm

Function (switchable)	Steady / fleeting contact
Alarm threshold adjustment range	Conductivity / resistance / concentration / temperature / USP: total measuring range
Alarm delay	0 ... 2000 s (min)

Accuracy**Conductivity measurement**

Measuring error ¹ Display	max. 0.5 % of measured value ± 4 digits
Repeatability	max. 0.2 % of measured value ± 2 digits
Measuring error ¹ conductivity of signal output	0.75 % of current output range

Resistance measurement

Measuring error ¹ display	max. 0.5 % of measured value ± 4 digits
Repeatability	max. 0.2 % of measured value ± 2 digits
Measuring error ¹ resistance of signal output	0.75 % of current output range

Temperature measurement

Measured value resolution	0.1 °C
Measured error ¹ display	max. 1.0 % of measuring range
Measured error ¹ temperature signal output	max. 1.25 % of current output range

Ambient conditions

Ambient temperature (nominal operating conditions)	-10 ... +55 °C
Ambient temperature (limit operating conditions)	-20 ... +60 °C
Storage and transportation temperature	-25 ... +65 °C
Relative humidity (nominal operating conditions)	10 ... 95 %, non-condensing
Ingress protection of panel-mounted instrument	IP 54 (front panel), IP 30 (enclosure)
Ingress protection of field instrument	IP 65
Pollution degree	2 acc. to IEC 61010-1
Installation category	II
Maximum altitude	2000 m above sea level
Electromagnetic compatibility	Interference emission and immunity to EN 61326: 1997/ A1: 1998

Mechanical construction

Dimensions of panel-mounted unit (H × W × D)	96 × 96 × 145 mm
Installation depth	approx. 165 mm
Dimensions of field instrument (H × W × D)	247 × 170 × 115 mm
Weight of panel-mounted unit	max. 0.7 kg
Weight of field instrument	max. 2.3 kg
Measured value display	LC display, 2-line, 5- and 9-digit with status indicators

Materials

Housing of panel-mounted unit	Polycarbonate
Front membrane	Polyester, UV-resistant
Field housing standard versions CSA GP version	ABS PC Fr Polycarbonate

Power supply

Supply voltage	100 / 115 / 230 V AC +10 / -15 %, 48 ... 62 Hz 24 V AC/DC +20 / -15 %
Power consumption	max. 7.5 VA
Mains fuse	Fine-wire fuse, medium time-lag 250 V / 3.15 A

¹According to IEC 746-1, for nominal operating conditions

Subjects to modifications.

11 Appendix

<p>Function group CALIBRATION C</p> <p>MEAS. VALUE DISPLAY with TEMPERATURE DISPLAY in °C</p> <p>Function group SETUP 1 A</p> <p>Function group SETUP 2 B</p> <p>Function group CURRENT OUTPUT O</p> <p>Function group ALARM F</p> <p>Function group CHECK P</p>	<p>InstF = Installation factor C1 (3)</p>	<p>Calibration temperature entry (MTC) 25.0 °C -35.0 ... +250.0 °C C131</p>	<p>Entry of α value of calibration solution 2.10 %/K 0.00 ... 20.00 %/K C132</p>	<p>Entry of correct conductivity value of calibration solution Current meas. value C133 0.0 μS/cm ... 9999 mS/cm</p>	<p>Display of calculated installation factor 1.0 0.10 ... 5.0 C134</p>	<p>Calibration status is displayed o.k.; E--- C135</p>
	<p>Cellc = Cell constant C1 (2)</p>	<p>Calibration temperature entry (if B1 = fixed) 25.0 °C -35.0 ... +250.0 °C C121</p>	<p>Entry of a α value of calibration solution 2.10 %/K 0.00 ... 20.00 %/K C122</p>	<p>Entry of correct conductivity value of calibration solution Current meas. value C123 0.0 mS/cm ... 9999 mS/cm</p>	<p>Display of calculated cell constant 0.0025 ... 99.99 1/cm C124</p>	<p>Calibration status is displayed o.k.; E--- C125</p>
	<p>AirS = Airset C1 (1)</p>	<p>Residual coupling Start calibration Current meas. value C111</p>	<p>Display of residual coupling (Airset) 0.0 μS C112</p>	<p>Calibration status is displayed o.k. E--- C113</p>	<p>Store calibration results yes; no; new C114</p>	
	<p>Temperature display in °F</p>	<p>Temperature display suppressed</p>	<p>Uncompensated measured value is displayed</p>			
	<p>1st error is displayed (if present)</p>	<p>Other errors are displayed (up to 10 errors)</p>				
	<p>Selection of operation mode cond = conductive ind = inductive MOhm = resistance conc = concentration A1</p>	<p>Selection of unit displayed ppm; mg/l; %; TDS; none (% only if A1 = conc) A2</p>	<p>Display format selection (if A1 = conc) XX.xx; X.xxx; XXX.x; XXXX A3</p>	<p>Selection of unit displayed auto; μS/cm; mS/cm; S/cm; μS/m; mS/m; S/m autoΩ; kΩ-cm; MΩ-cm; kΩ-m (omitted if A1 = conc) A4</p>	<p>Entry of cell constant cond / ind / MOhm 1.000 / 1.98 / 0.01 1/cm 0.0025 ... 99.99 1/cm for cond; ind; MOhm A5</p>	<p>Entry of cable resistance (if A1 = cond) 0.00 Ω 0.00 ... 99.99 Ω A6</p>
	<p>Selection of temperature measurement Pt100 Pt1k (= Pt 1000) NTC30 (= NTC 30 kΩ) fixed B1</p>	<p>Selection of temperature compensation type none lin = linear Tab = table NaCl = common salt B2 Pure = ultrapure water</p>	<p>Entry of α value (if B2 = linear) 2.10 %/K 0.00 ... 20.00 %/K B3</p>	<p>Entry of correct process temperature (if B1 = fixed) 25.0 °C -35.0 °C ... +250.0 °C B4</p>	<p>Temperature sensor calibration (omitted if B1 = fixed) Display of actual value -35.0 ... +250.0 °C B5</p>	<p>Enter temperature difference (omitted if B1 = fixed) Current offset -5.0 ... 5.0 °C B6</p>
		<p>Characteristic selection table O2 (3) sim = simulation O2 (2) lin = linear O2 (1)</p>	<p>Table option selection read edit O231</p>	<p>Entry of number of value pairs in table 1 1 ... 10 O232</p>	<p>Selection of value pair in table 1 1 ... number of value pairs assign O233</p>	<p>x value entry (measured value) 0 μS/cm / 0 kΩ-cm / 0 % / 0 °C entire measuring range O234</p>
	<p>Current output selection Out1; Out2 O1</p>		<p>Simulation value entry current value 0 ... 22.00 mA O221</p>	<p>Current range selection 4-20 mA; 0-20 mA O211</p>	<p>Entry of 0/4 mA value 0 μS/cm / 0 kΩ-cm / 0 % / 0 °C entire measuring range O212</p>	<p>Entry of 20 mA value 2000 mS/cm / 500 kΩ-cm / 9999 % / 150.0 °C entire measuring range O213</p>
	<p>Select contact type Stead = steady contact; Fleet = fleeting contact F1</p>	<p>Select alarm delay unit s; min F2</p>	<p>Alarm delay 0 s (min) 0 s ... 2000 s (min) (depends on F2) F3</p>	<p>Error current setting 22 mA 2.4 mA F4</p>	<p>Error number selection 1 1 ... 255 F5</p>	<p>Set alarm contact to be effective yes; no F6</p>
	<p>Switch polarisation detection on or off off; on P1</p>	<p>PCS alarm setting (live-check) off / 1h / 2h / 4h P2</p>				



Store calibration results yes; no; new C136

Store calibration results yes; no; new C126

Entry of measured value damping 1 (no damping) 1 ... 60 A7

y value entry (current value) 0.00 mA 0 ... 20.00 mA entire measuring range O235

Table status ok yes; no O236

Activate error current for previously set error no; yes F7

Automatic start of cleaning function no; yes (not always displayed, see error messages) F8

Select "next error" or return to menu next = next error ← R F9

Field for customer settings

	Limit contactor configuration	Function of R2 (6) Switch off or on	Entry of alarm threshold (switch-on point)	Entry of switch-off point	Pickup delay entry	
	USP R2 (6)	Off; On R261	80 % 0.0 ... 100.0 % R262	80 % 0.0 ... 100.0 % R263	0 0 ... 2000 s R264	
	Clean = Chemoclean (only with rel. 3 and rel. 4)	Function of R2 (5) Switch off or on	Start pulse selection int = internal ext = external +ext = internal + external +stp = internal, suppr. by ext	Entry of pre-rinse time	Entry of cleaning time	
	R2 (5)	Off; On R251	R252	20 s 0 ... 999 s R253	10 s 0 ... 999 s R254	
	Timer	Function of R2 (4) Switch off or on	Rinse time setting	Pause time setting	Set minimum pause time	
	R2 (4)	Off; On R241	30 s 0 ... 999 s R242	360 min 1 ... 7200 min R243	120 min 1 ... 3600 min R244	
	PID controller	Function of R2 (3) Switch off or on	Entry of set point	Entry of control gain Kp	Entry of integral action time Tn (0.0 = no I component)	
	R2 (3)	Off; On R231	0 µS/cm / 0 kΩ·cm / 0 % entire meas. range R232	1.00 0.01 ... 20.00 R233	0.0 min 0.0 ... 999.9 min R234	
	LC °C = T limit contactor	Function of R2 (2) Switch off or on	Entry of switch-on temperature	Entry of switch-off temperature	Pickup delay setting	
	R2 (2)	Off; On R221	250.0 °C -35.0 ... +250.0 °C R222	250.0 °C -35.0 ... +250.0 °C R223	0 s 0 ... 2000 s R224	
	LC PV = cond. limit contactor	Function of R2 (1) Switch off or on	Select contact switch-on point	Select contact switch-off point	Pickup delay setting	
	R2 (1)	Off; On R211	9999 mS/cm / 200 MΩ·cm / 9999 % entire meas. range R212	9999 mS/cm / 200 MΩ·cm / 9999 % entire meas. range R213	0 s 0 ... 2000 s R214	
Function group RELAY	Select contact to be configured Rel1; Rel2; Rel3; Rel4					
	R	R1				
Function group ALPHA TABLE	Table option selection read edit	Entry of number of table value pairs	Selection of table value	Entry of temperature value (x value)	Entry of temperature coefficient (y value)	Table status o.k.
	T	1 1 ... 10 T1	1 1 ... number of table value pairs assign T2	0.0 °C -35.0 ... +250.0 °C T4	2.10 %/K 0.00 ... 20.00 %/K T5	yes; no T6
Function group CONCENTRATION	Selection of concentration curve for calculation of display value Curve 1 ... 4	Selection of table to be edited	Table option selection	Set number of value pairs	Select value pair	Entry of uncompensated conductivity value
	K	1 1 ... 4 K1	read edit K2	1 1 ... 10 K3	1 1 ... number of value pairs in K4 K4	0.0 µS/cm 0.0 ... 9999 mS/cm K5
Function group SERVICE	Language selection ENG; GER ITA; FRA ESP; NEL	Hold configuration - none = no hold - s+c = during setup and calibration - CAL = during calibration - Setup = during setup	Manual hold off; on	Entry of hold dwell period	Entry of SW upgrade release code (plus package)	Entry of SW upgrade release code Chemoclean
	S	S1	S2	10 s 0 ... 999 s S3	0000 0000 ... 9999 S4	0000 0000 ... 9999 S5
	Module selection	Software version	Hardware version	Serial number is displayed	Module name is displayed	
	Relay E1 (4)	SW version E141	HW version E142	E143	E144	
	MainB = mainboard E1 (3)	SW version E131	HW version E132	E133	E134	
	Trans = transmitter E1 (2)	SW version E121	HW version E122	E123	E124	
Function group E + H SERVICE	Contr = controller E1 (1)	SW version E111	HW version E112	E113	E114	
Function group INTERFACE	Entry of address HART: 0 ... 15 or Profibus 1 ... 126					
	I	I1				

Dropout delay entry
0 0 ... 2000 s
R265

Entry of post-rinse time
20 s 0 ... 999 s
R255

Number of repeat cycles
0 0 ... 5
R256

Set interval between two cleaning cycles (pause time)
360 min 1 ... 7200 min
R257

Set minimum pause time
120 min 1 ... R357 min
R258

Number of cleaning cycles without cleaning agent
0 0 ... 9
R259

Entry of derivative action time Tv (0.0 = no D component)
0.0 min 0.0 ... 999.9 min
R235

Selection of control characteristic
dir = direct; inv = inverted
R236

Selection
len = pulse length freq = pulse frequency
R237

Entry of pulse interval
10.0 s 0.5 ... 999.9 s
R238

Entry of max. pulse frequency
120 1/min 60 ... 180 1/min
R239

Entry of min. ON time t _{on}
0.3 s 0.1 ... 5.0 s
R2310

Dropout delay setting
0 s 0 ... 2000 s
R225

Setting of alarm threshold
250.0 °C -35.0 ... +250.0 °C
R226

Dropout delay setting
0 s 0 ... 2000 s
R215

Setting of alarm threshold (as an absolute value)
9999 mS/cm / 200 MΩ cm / 9999 % entire meas. range
R216

Entry of associated concentration value
0.00 % 0 ... 99.99 %
K7

Entry of associated temperature value
0.0 °C -35.0 ... 250.0 °C
K8

Table status o.k.
yes; no
K9

Order number is displayed
S7

Serial number is displayed
S8

Reset instrument (restore default values)
no; Sens = sensor data; Facy = factory settings
S9

Perform instrument test
no; Displ = display
S10

12 Index

0	17, 20	Current outputs	26
22	20	CYK 71	14
9999	17, 20		
A			
A-Function group	24, 25	D	
Access codes	20	D component	32, 38
Accessories	71, 72	Damage	2
ALARM (F)	28	Derivative action time	38
Alarm contact	28, 29	Device upgrade	71
Alarm delay	29	Diagnosis	59-70
Alarm threshold	37, 41	Dimensions	7
ALPHA TABLE (T)	43	Disassembly of CLM 223	62
Assemblies	71	Disassembly of CLM 253	65
Assembly of CLM 223	62	Display	16
Assembly of CLM 253	65	Disposal	2
AUTO key	17	Dropout delay	36, 37, 41
Automatic start of cleaning	29		
Automatischer Reinigungsstart	57	E	
B			
B-Function group	25, 26	E-Function group	48
C			
C-Function group	49, 50, 51	Economy function	41
Cable length	14	Electrical connection	12
Calibration	49	Electronics box	7
Calibration mode	19, 22	Error codes	57
Calibration of inductive sensors	49	Error current	29
Calibration with sensor alignment	51	Extension cable CLK 5	71
Certificate of conformity	5	Extension cable CMK	71
CHECK (P)	30	Extension of measuring cable	14
Chemoclean function	31, 35		
Cleaning function	39	F	
Cleaning time	35, 40	F-Function group	28, 29
Cleaning trigger	29	Factory settings	22
CLK 5	14, 71	Function coding	22
Code 0	17	Function group	20
Code 22	20	Fuse	7, 75
Code 9999	17		
Coding	22	G	
Coding structure	22	General	2, 3
Complete Installation	6	General safety notes	4
Complete measuring system	6		
CONCENTRATION (K)	45	H	
Concentration measurement	44	Hardware version	48
Conductivity sensors	72	HART	48
Configure temperature sensor	26	Hazards	2
Connection diagram	12	Hold delay time	35, 47
Connection examples	15	Hold function	21
Connections of field instrument	13		
Connections of panel-mounted instrument	13	I	
Contact selection	28	I component	32, 38
Control characteristic	34	I-Function group	48
Controller characteristic	38	Immunity to interference	5
Corrective maintenance of CLM 223	61	Installation	4-15
Corrective maintenance of CLM 253	64	Instrument configuration	22-30
Corrective maintenance of measuring system	68	Integral action time	38
CURRENT OUTPUT (O)	26	Intended application	4
Current output table	27	INTERFACE (I)	48
		Interfaces	52
		J	
		Junction box VBM	14, 71

K		Process temperature	26
K-Function group	45	Product structure	3
Key functions	17	PROFIBUS	48
Kp	38	Programming	20
		Pulse frequency	38
L		Pulse frequency modulation	33
LED indicator	16	Pulse interval	38
Limit contactor	31	Pulse length	38
Limit contactor	36	Pulse length modulation	33
Limit contactor for conductivity measured value	31		
Limit contactor for temperature	31, 37	Q	
Linear characteristic	26	Queries	2
Liquid crystal display	16		
Locking the keypad	17, 20	R	
		R-Function group	36-40
M		REL key	17
Maintenance and troubleshooting	53-58	RELAY (R)	36
Manual hold	47	Relay contact configuration	31
		Repeat cycles	40
Measuring cable connection	14	Replacement of processor module	67
Measuring mode	22	Rinse time	39
Measuring system	6		
Menu structure	20	S	
Minimum pause time	39, 40	S-Function group	46, 47
MINUS key	17	Safety	4, 5
Module name	48	Safety features	5
Monitoring features	5	Safety instructions	4, 5
Mounting	8	Safety notes	4
Mounting examples	10	Scope of delivery	2
Mounting of CLM 223	62	Scopeware	67
Mounting of CLM 253	65	Select language	46
Mounting of field instrument	8	Selection of error	29
		Selection of time unit	28
O		Self test	22
O-Function group	26-28	Sensor adaptations	51
ON time	39	Sensor installation	14
Operating concept	19	Sensor COS 21	71
Operating modes	19	Serial number	48
Operation	4, 16-21	Service	59
Operator interface	16	SERVICE (S)	24, 46
Optoscope	67	SETUP 1 (A)	24
Order code	47	SETUP 2 (B)	24, 25
		Setup mode	19, 22
P		Shipping documents	2
P controller	32	Simulation	27
P(ID) controller	31	Software version	48
P-Function group	30	Spare parts for CLM 223	63
Packaging	2	Spare parts for CLM 253	66
Panel-mounted instrument	11	Spare parts orders	67
Partition plate	7	Start pulse	40
Pause time	39, 40	start-up	4
PCS alarm	30	Start-up menu	24
PD controller	32	Storage	2
PI controller	32	Structure of measuring cable	14
Pickup delay	36, 37, 41	SW upgrade	47
PID controller	32, 38	Switch-off point of contact	36
PLUS key	17	Switch-off temperature	37
Polarisation recognition	30	Switch-on point of contact	36
Post mounting kit	9	Switch-on temperature	37
Post mounting on a square post	8	Symbols	2
Post mounting on cylindrical pipes	8	Symbols used	2
Post-rinse time	35, 40	System configuration	24
Pre-rinse time	35, 40		
Prealarm	41		

T		U	
T-Function group	43	Universal mounting post CYY 102	9
Technical data	73-75	Unlocking the keypad	17, 20
Temperature coefficient	42	Unpacking	2
Temperature compensation	25, 42	Upright post CYY 102	71
Temperature sensor	25	USP 23	31, 41
Terminal blocks	7	USP 23 Function	34
Termination of measuring cable	14		
Time unit	28	W	
Timer for cleaning function	31, 35	Wall mounting	8
Tn	38	Weather protection cover CYY 101	8, 71
Transport	2		
Troubleshooting common problems	53		
Tv	38		

Declaration of contamination

Dear customer,
Because of legal determinations and for the safety of our employees and operating equipment we need this "Declaration of contamination" with your signature before your order can be handled. Please put the completely filled in declaration to the instrument and to the shipping documents in any case. Add also safety sheets and/or specific handling instructions if necessary.

type of instrument / sensor: _____ serial number: _____
medium / concentration: _____ temperature: _____ pressure: _____
cleaned with: _____ conductivity: _____ viscosity: _____

Warning hints for medium used:



radioactive



explosive



caustic



poisonous



harmful of
health



biological
hazardous



inflammable



safe

Please mark the appropriate warning hints.

Reason for return:

Company data:

company: _____	contact person: _____
_____	_____
_____	department: _____
address: _____	phone number: _____
_____	Fax/E-Mail: _____
_____	your order no.: _____

I hereby certify that the returned equipment has been cleaned and decontaminated acc. to good industrial practices and is in compliance with all regulations. This equipment poses no health or safety risks due to contamination.

(Date)

(company stamp and legally binding signature)



Europe

Austria

□ Endress+Hauser Ges.m.b.H.
Wien
Tel. (01) 880 56-0, Fax (01) 880 56-35

Belarus

Belorgsintez
Minsk
Tel. (01 72) 50 84 73, Fax (01 72) 50 85 83

Belgium / Luxembourg

□ Endress+Hauser N.V.
Brussels
Tel. (02) 248 06 00, Fax (02) 248 05 53

Bulgaria

INTÉRTÉCH-AUTOMATION
Sofia
Tel. (02) 66 48 69, Fax (02) 9 63 13 89

Croatia

□ Endress+Hauser GmbH+Co.
Zagreb
Tel. (01) 663 77 85, Fax (01) 663 78 23

Cyprus

I+G Electrical Services Co. Ltd.
Nicosia
Tel. (02) 48 47 88, Fax (02) 48 46 90

Czech Republic

□ Endress+Hauser GmbH+Co.
Praha
Tel. (026) 6 78 42 00, Fax (026) 6 78 41 79

Denmark

□ Endress+Hauser A/S
Søborg
Tel. (70) 13 11 32, Fax (70) 13 21 33

Estonia

ELVI-Aqua
Tartu
Tel. (7) 44 16 38, Fax (7) 44 15 82

Finland

□ Endress+Hauser Oy
Espoo
Tel. (09) 86 76 74 00, Fax (09) 86 76 74 40

France

□ Endress+Hauser S.A.
Huningue
Tel. (389) 69 67 68, Fax (389) 69 48 02

Germany

□ Endress+Hauser Messtechnik GmbH+Co.
Weil am Rhein
Tel. (0 76 21) 9 75-01, Fax (0 76 21) 9 75-55 55

Great Britain

□ Endress+Hauser Ltd.
Manchester
Tel. (01 61) 2 86 50 00, Fax (01 61) 9 98 18 41

Greece

I & G Building Services Automation S.A.
Athens
Tel. (01) 9 24 15 00, Fax (01) 9 22 17 14

Hungary

Mile Ipari-Elektro
Budapest
Tel. (01) 2 61 55 35, Fax (01) 2 61 55 35

Iceland

BIL ehf
Reykjavik
Tel. (05) 61 96 16, Fax (05) 61 96 17

Ireland

Flomeaco Company Ltd.
Kildare
Tel. (0 45) 86 86 15, Fax (0 45) 86 81 82

Italy

□ Endress+Hauser Italia S.p.A.
Cernusco s/N Milano
Tel. (02) 92 19 21, Fax (02) 92 10 71 53

Latvia

Rino TK
Riga
Tel. (07) 31 50 87, Fax (07) 31 50 84

Lithuania

UAB "Agava"
Kaunas
Tel. (07) 20 24 10, Fax (07) 20 74 14

Netherlands

□ Endress+Hauser B.V.
Naarden
Tel. (0 35) 6 95 86 11, Fax (0 35) 6 95 88 25

Norway

□ Endress+Hauser A/S
Tranby
Tel. (0 32) 85 98 50, Fax (0 32) 85 98 51

Poland

□ Endress+Hauser Polska Sp. z o.o.
K. Warszawa
Tel. (0 22) 7 20 10 90, Fax (0 22) 7 20 10 85

Portugal

Tecnisis, Lda
Cacém
Tel. (0 21) 4 26 72 90, Fax (0 21) 4 26 72 99

Romania

Romconseng S.R.L.
Bucharest
Tel. (01) 4 10 16 34, Fax (01) 4 11 25 01

Russia

□ Endress+Hauser Moscow Office
Moscow
Tel. (0 95) 1 58 75 64, Fax (0 95) 1 58 98 71

Slovakia

Transcom Technik s.r.o.
Bratislava
Tel. (7) 44 88 86 84, Fax (7) 44 88 71 12

Slovenia

□ Endress+Hauser D.O.O.
Ljubljana
Tel. (0 61) 15 19 22 17, Fax (0 61) 15 19 22 98

Spain

□ Endress+Hauser S.A.
Sant Just Desvern
Tel. (0 93) 4 80 33 66, Fax (0 93) 4 73 38 39

Sweden

□ Endress+Hauser AB
Sollentuna
Tel. (08) 55 51 16 00, Fax (08) 55 51 16 55

Switzerland

□ Endress+Hauser Metso AG
Reinach/BL 1
Tel. (0 61) 7 15 75 75, Fax (0 61) 7 11 16 50

Turkey

Intek Endüstriyel Ölçü ve Kontrol Sistemleri
Istanbul
Tel. (02 12) 2 75 13 55, Fax (02 12) 2 66 27 75

Ukraine

Photonika GmbH
Kiev
Tel. (44) 2 68 81, Fax (44) 2 69 08

Yugoslavia

Meris d.o.o.
Beograd
Tel. (11) 4 44 19 66, Fax (11) 4 44 19 66

Africa

Egypt

Anasia
Heliopolis/Cairo
Tel. (02) 4 17 90 07, Fax (02) 4 17 90 08

Morocco

Oussama S.A.
Casablanca
Tel. (02) 24 13 38, Fax (02) 40 26 57

South Africa

□ Endress+Hauser Pty. Ltd.
Sandton
Tel. (0 11) 2 62 80 00, Fax (0 11) 2 62 80 62

Tunisia

Controle, Maintenance et Regulation
Tunis
Tel. (01) 79 30 77, Fax (01) 78 85 95

America

Argentina

□ Endress+Hauser Argentina S.A.
Buenos Aires
Tel. (01) 1 45 22 79 70, Fax (01) 1 45 22 79 09

Bolivia

Tritec S.R.L.
Cochabamba
Tel. (0 42) 5 69 93, Fax (0 42) 5 09 81

Brazil

□ Samson Endress+Hauser Ltda.
Sao Paulo
Tel. (0 11) 50 31 34 55, Fax (0 11) 50 31 30 67

Canada

□ Endress+Hauser Ltd.
Burlington, Ontario
Tel. (9 05) 6 81 92 92, Fax (9 05) 6 81 94 44

Chile

□ Endress+Hauser Chile Ltd.
Santiago
Tel. (02) 3 21 30 09, Fax (02) 3 21 30 25

Colombia

Colsein Ltda. Bogota D.C.
Tel. (01) 2 36 76 59, Fax (01) 6 10 41 86

Costa Rica

EURO-TEC S.A.
San Jose
Tel. (02) 96 15 42, Fax (02) 96 15 42

Ecuador

Insetec Cia. Ltda.
Quito
Tel. (02) 26 91 48, Fax (02) 46 18 33

Guatemala

ACISA Automatizacion Y Control Industrial S.A.
Ciudad de Guatemala, C.A.
Tel. (03) 34 59 85, Fax (03) 32 74 31

Mexico

□ Endress+Hauser S.A. de C.V.
Mexico City
Tel. (5) 5 68 24 05, Fax (5) 5 68 74 59

Paraguay

Incoel S.R.L.
Asuncion
Tel. (0 21) 21 39 89, Fax (0 21) 22 65 83

Uruguay

Circular S.A.
Montevideo
Tel. (02) 92 57 85, Fax (02) 92 91 51

USA

□ Endress+Hauser Inc.
Greenwood, Indiana
Tel. (3 17) 5 35-71 38, Fax (3 17) 5 35-84 98

Venezuela

CONTROLVAL C.A.
Caracas
Tel. (02) 9 44 09 66, Fax (02) 9 44 45 54

Asia

China

□ Endress+Hauser Shanghai
Instrumentation Co. Ltd.
Shanghai
Tel. (0 21) 54 90 23 00, Fax (0 21) 54 90 23 03

□ Endress+Hauser Beijing Office

Beijing
Tel. (0 10) 68 34 40 58, Fax (0 10) 68 34 40 68

Hong Kong

□ Endress+Hauser HK Ltd.
Hong Kong
Tel. 25 28 31 20, Fax 28 65 41 71

India

□ Endress+Hauser (India) Pvt Ltd.
Mumbai
Tel. (0 22) 8 52 14 58, Fax (0 22) 8 52 19 27

Indonesia

PT Grama Bazita
Jakarta
Tel. (21) 7 97 50 83, Fax (21) 7 97 50 89

Japan

□ Sakura Endress Co., Ltd.
Tokyo
Tel. (04 22) 54 06 13, Fax (04 22) 55 02 75

Malaysia

□ Endress+Hauser (M) Sdn. Bhd.
Petaling Jaya, Selangor Darul Ehsan
Tel. (03) 7 33 48 48, Fax (03) 7 33 88 00

Pakistan

Speedy Automation
Karachi
Tel. (0 21) 7 72 29 53, Fax (0 21) 7 73 68 84

Philippines

□ Endress+Hauser Philippines Inc.
Metro Manila
Tel. (2) 3 72 36 01-05, Fax (2) 4 12 19 44

Singapore

□ Endress+Hauser (S.E.A.) Pte., Ltd.
Singapore
Tel. 5 66 82 22, Fax 5 66 68 48

South Korea

□ Endress+Hauser (Korea) Co., Ltd.
Seoul
Tel. (02) 6 58 72 00, Fax (02) 6 59 28 38

Taiwan

Kingjari Corporation
Taipei R.O.C.
Tel. (02) 27 18 39 38, Fax (02) 27 13 41 90

Thailand

□ Endress+Hauser Ltd.
Bangkok
Tel. (2) 996 78 11-20, Fax (2) 996 78 10

Vietnam

Tan Viet Bao Co. Ltd.
Ho Chi Minh City
Tel. (08) 8 33 52 25, Fax (08) 8 33 52 27

Iran

PATSA Co.
Tehran
Tel. (0 21) 8 75 47 48, Fax (0 21) 8 74 77 61

Israel

Instrumetrics Industrial Control Ltd.
Tel-Aviv
Tel. (03) 6 48 02 05, Fax (03) 6 47 19 92

Jordan

A.P.Parpas Engineering S.A.
Amman
Tel. (06) 4 64 32 46, Fax (06) 4 64 57 07

Kingdom of Saudi Arabia

Anasia Ind. Agencies
Jeddah
Tel. (02) 6 71 00 14, Fax (02) 6 72 59 29

Lebanon

Network Engineering
Jbeil
Tel. (9) 94 40 80, Fax (9) 54 80 38

Sultanate of Oman

Mustafa & Jawad Science & Industry Co. L.L.C.
Ruwi
Tel. 60 20 09, Fax 60 70 66

United Arab Emirates

Descon Trading EST.
Dubai
Tel. (04) 2 65 36 51, Fax (04) 2 65 32 64

Yemen

Yemen Company for Ghee and Soap Industry
Taiz
Tel. (04) 23 06 64, Fax (04) 21 23 38

Australia + New Zealand

Australia

ALSTOM Australia Ltd.
Milperra
Tel. (02) 97 74 74 44, Fax (02) 97 74 46 67

New Zealand

EMC Industrial Group Ltd.
Auckland
Tel. (09) 4 15 51 10, Fax (09) 4 15 51 15

All other countries

□ Endress+Hauser GmbH+Co.
Instruments International
D-Weil am Rhein
Germany
Tel. (0 76 21) 9 75-02, Fax (0 76 21) 9 75-34 5

□ Members of the Endress+Hauser group



51500270

Endress + Hauser

The Power of Know How

