

## INSTALLATION & MAINTENANCE INSTRUCTIONS

### Proportional Electronic Pressure Regulator with Integral Volume Booster

#### DESCRIPTION

The QL3 is a closed loop electronic pressure regulator consisting of two solenoid valves, an internal pressure transducer, and an electronic control circuit integrally mounted to a unique volume booster. The output pressure is proportional to an electrical input (command signal). The pressure is controlled by activating the solenoid valves, which apply pressure to the pilot side of the volume booster. One valve functions as inlet control, the other as exhaust. The output pressure of the volume booster is measured by a pressure transducer, which is internally mounted and provides a feedback signal to the electronic control circuit. This feedback signal is compared against the command signal input. Any differences between the command signal and the pressure feedback signal causes one of the solenoid valves to open to adjust the pressure in the pilot of the volume booster. Pilot pressure is adjusted so that desired output pressure is achieved and maintained. Since it is the actual desired work pressure that is being sensed and fed back to the control circuit, any mechanical hysteresis of the air piloted volume booster is automatically compensated for. This allows for our extraordinary accuracy and repeatability.

The QL3 improves and builds on the proven Proportion-Air QB3 series high performance by using a current driven variable orifice solenoid valve and a unique analog PID circuit. This variable orifice solenoid avoids the pressure “steps” prevalent in most feed and bleed I/P’s. The PID circuit integrates error out quickly resulting in superior resolution. The combination of a step less solenoid valve with a high speed analog PID on a high flow volume booster allows lots of air to be moved in a hurry, but precisely.

Command inputs come in a choice of either a 0-10 VDC or 4-20 mA. The QL3 also provides an electrical monitor signal for output to a panel meter or controller for data acquisition or quality assurance needs. The monitor signal comes from the internal pressure transducer. All QL3’s come standard with a 0-10 volt monitor signal with 4-20 mA optional. Providing this monitor signal as part of our standard package eliminates the need to purchase a separate transducer.

The uniqueness of the volume booster design is that it has no stamped gaskets or special molded diaphragm or seal parts. All of the parts related to normal maintenance are standard O-rings. Complete repair kits are available, but in case emergency repair is needed parts should be available from any fluid power distributor or even most neighborhood hardware stores. Since all sealing parts are O-rings a large variety of chemical compounds are readily available. You can select the compounds, which are most ideally suited to your process and environment.

The QL3 is used for pressures up to 120 psig. For pressure ranges between 121 and 500 psig, see the Proportion-Air QB3H series.

**PROPORTION-AIR, INC.**  
8250 N. 600 West  
McCordsville, IN 46055  
317.335.2602

[info@proportionair.com](mailto:info@proportionair.com)



#### SPECIFICATIONS

##### ELECTRICAL

SUPPLY VOLTAGE	15-24 VDC
SUPPLY CURRENT	250 mA Max
COMMAND SIGNAL	0-10 VDC   4-20 mA (typical)
COMMAND SIGNAL IMPEDANCE	VDC = 4.7 KΩ   Current = 100 Ω
VOLTAGE MONITOR SIGNAL	0-10 VDC @ 10 mA max
CURRENT MONITOR SIGNAL	4-20 mA Sinking (sourcing opt)

##### MECHANICAL

PRESSURE RANGES	0-5 PSIG through 0-150 PSIG (0-0.34 BAR through 0-10.3 BAR)
OUTPUT PRESSURE†	0-100% of range
FLOW RATE	25 SCFM @ 120 PSIG inlet & 100 PSIG output (708 L/min @ 8.3 Bar inlet & 6.9 Bar)
PORT SIZE	1/4" NPT
Min CLOSED END VOLUME	5 in <sup>3</sup>
FILTRATION RECOMMENDED	40 Micron
LINEARITY	<±0.3% F.S. BFSL
HYSTERESIS	0.05% F.S.
ACCURACY (includes hysteresis & linearity)	<±0.4% F.S.
RESOLUTION	0.05% F.S.

##### WETTED PARTS ‡

ELASTOMERS	Buna N (3)
MANIFOLD	Aluminum Nickel Plated
VALVES	430FR SS, 360 Brass
SEAL MATERIAL	Viton & Buna-N
PRESSURE TRANSDUCER	Utem 1000, Aluminum

##### PHYSICAL

OPERATING TEMPERATURE	32-158°F (0-70°C)
DIMENSIONS	2"x2"x4.4" (51mmX51mmX111mm)
WEIGHT	1.5 lbs. (0.68 kg)
PROTECTION RATING	IP65
HOUSING	Aluminum (Anodized)

† Pressure ranges are customer specified. Output pressures other than 100% are available. ‡ Others available

## Before you get started, please read these warnings:

- ◆ Examine the product. Ensure that you received what you ordered.
- ◆ Read this guide first before you start and save it for later use.
- ◆ You must have a good understanding of what the adjustments are on this product before using them.
- ◆ All compressed air and power should be shut off before installing, removing or performing maintenance on this product.
- ◆ Installation and use of this product should be under the supervision and control of properly qualified personnel in order to avoid the risk of injury or death.

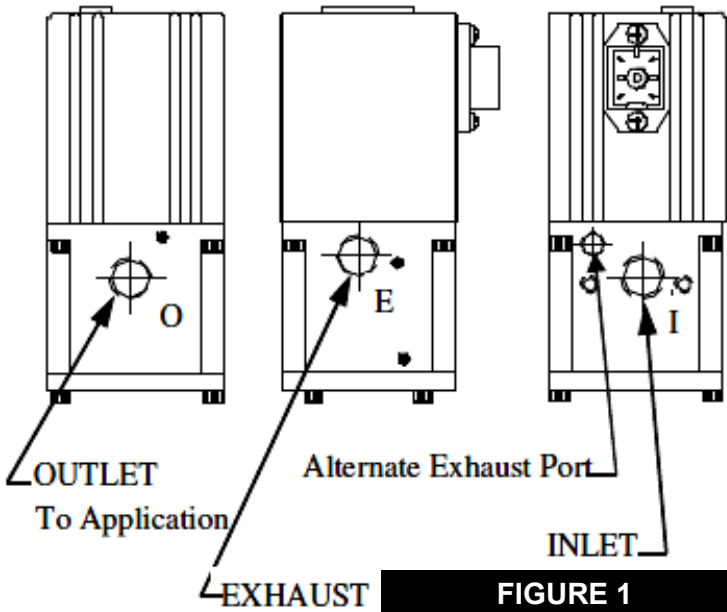

FIGURE 1

## CONNECTION PROCEDURE

### Pneumatic Connections

**CAUTION:** USE ONLY THE THREAD SEALANT PROVIDED. OTHER SEALANTS SUCH AS PTFE TAPE AND PTFE PASTE CAN MIGRATE INTO THE FLUID SYSTEM CAUSING FAILURES.

1. The valve can be mounted in any position without affecting performance. A variety of mounting brackets (QBT-01, QBT-02, and QBT-03. SEE ordering info) can be used to attach valve to a panel or wall surface. Note: Very low pressure units work best when mounted upright.
2. A typical 40 micron in-line filter is recommended on the inlet of the QL3 valve. This is available from Proportion-Air as part number FPP-2.
3. A 1/16" plug is supplied with the valve. It can be used to plug the "Alternate Exhaust Port" if the exhaust media should be captured or when the valve is used for vacuum or vacuum through positive pressure control. (See Figure 1 for port location.)

### Positive Pressure Units

1. Connect supply pressure to the "I" port (Figure 1) not to exceed rated supply pressure. (See TABLE 1)
2. Connect the outlet "O" port (Figure 1) to the device being controlled.
3. The "E" exhaust port can be plumbed to a point outside the work area, fitted with a muffler or left open to atmosphere as the application dictates.
4. Proceed with electrical connection.

## Electrical Connections

1. Turn off all power before making electrical connections.
2. Identify the valve's command input and analog output using the calibration card included in the package and the ordering information section on the last page of this sheet.
3. Proceed to the appropriate section corresponding to the type of valve being installed.

**NOTE: ALL COLOR CODES RELATE TO QL3'S ORDERED FROM THE FACTORY WITH PREASSEMBLED QBT-C-X CABLES.**

## COMMAND SIGNAL CONFIGURATIONS

### VOLTAGE COMMAND VALVES (E, K, V)

All voltage command QL3's use common mode voltage, meaning the DC Common pin (Pin-1) is the common reference for both power and command. Pin 1 is used as both the command signal common and power supply common. The following diagram shows the proper connections.

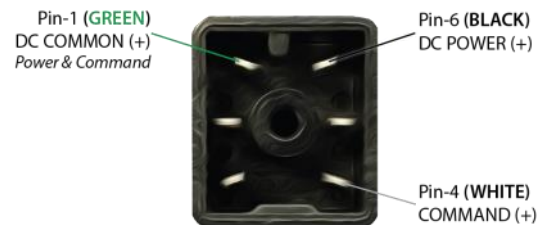

### CURRENT COMMAND VALVES (I)

All current command QL3's use a differential current loop scheme (not isolated), meaning current flow is from Pin 4 to Pin 2 on the QB valve. Some applications may require the common of the power supply that provides loop power for the 4-20mA command to be tied to power supply common. The following diagram shows the correct connection for conventional current flow.

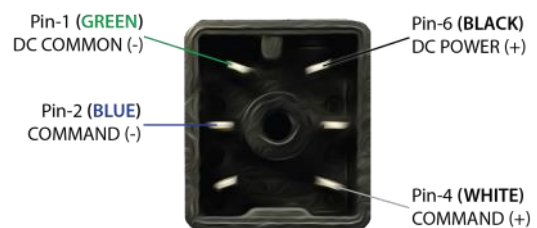

## MONITOR SIGNAL CONFIGURATIONS

### VOLTAGE COMMAND VALVES (E, K, V)

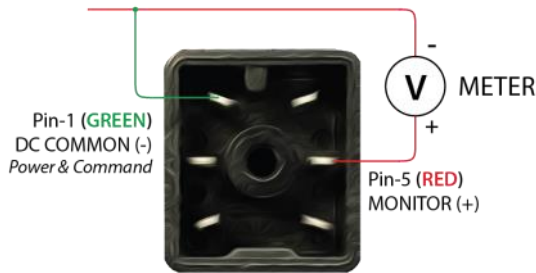

### CURRENT Sinking Monitor (C)

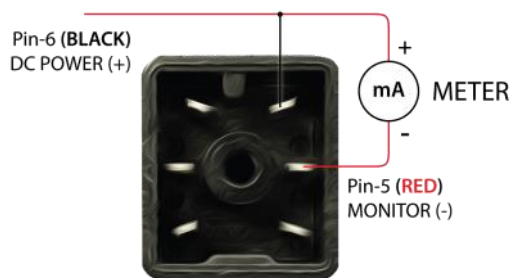

### CURRENT Sourcing Monitor (S)

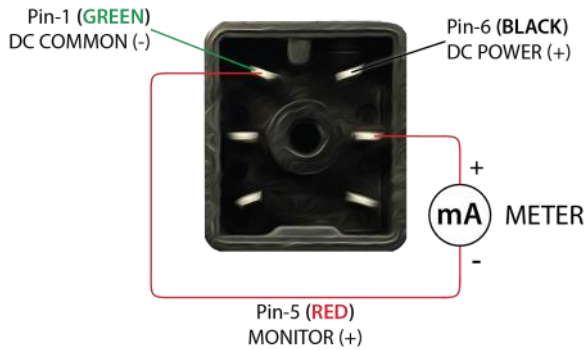

## RE-CALIBRATION PROCEDURE:

All QL3 control valves come calibrated from the factory by trained personnel using precision calibration equipment. The QL3 valve is a closed loop control valve using a precision electronic pressure sensor. Typical drift is less than 1% over the life of the product. If your QL3 valve appears to be out of calibration by more than 1%, it is not likely to be the QL3. Check the system for plumbing leakage, wiring and electronic signal levels. Verify the accuracy of your measuring equipment before re-calibrating. Consult factory if you have any questions or require assistance.

Calibration Access Cap

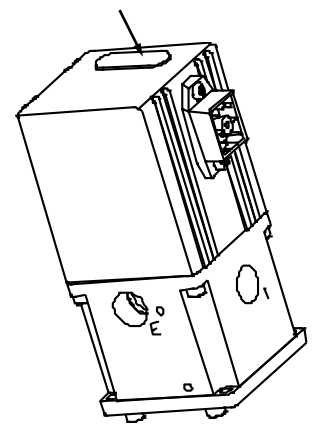
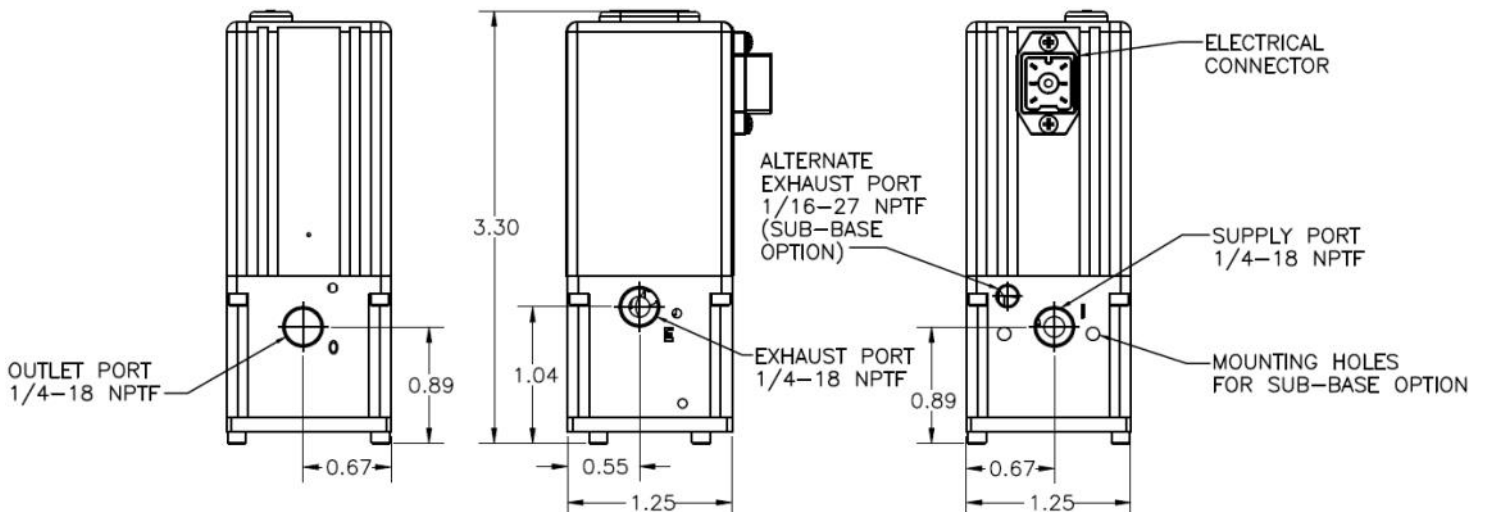
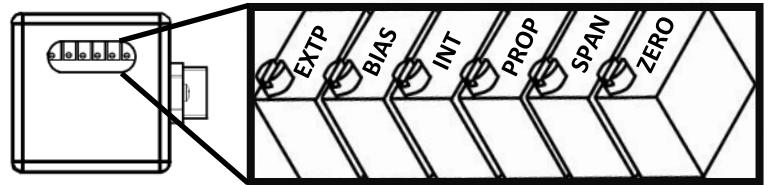

FIGURE 2

Potentiometer Identifiers:  
 EXTP—Exhaust Trip Point  
 INT—Integral  
 PROP—Proportional

PID settings are factory set and should not require re-calibration. If needed, please consult factory for adjustment procedures.



# QL3

Example Part Number

ACCURACY	±0.4% F.S.	PRESSURE	0-5 thru 0-125 psig (8.6 Bar)									
PORT SIZE	1/4"	MAX FLOW	25 SCFM (708 SLPM)									
QL3	3	A	N	E	E	Z	P	125	PS	G	O2	
		1	2	3	4	5	6	7	8	9	10	OPTIONS

## Section Reference

<b>1</b>	<b>Manifold Material</b>		
<b>A</b>	Nickel-Plated Aluminum		
<b>B</b>	Nickel-Plated Brass (includes O2 cleaning)		
<b>2</b>	<b>Thread Type</b>		
<b>N</b>	NPT		
<b>P</b>	BSPP		
<b>3</b>	<b>Input Signal Range</b>		
<b>E</b>	0 to 10 VDC		
<b>I</b>	4 to 20 mA DC		
<b>K</b>	0 to 5 VDC		
<b>V</b>	1 to 5 VDC*		
<b>A</b>	RS232 Serial Input* <sup>1</sup>		
<b>B</b>	RS485 Serial Input* <sup>1</sup>		
<b>P</b>	P2 Profiler (integrated)		
	*Requires <b>V</b> for Monitor Signal (#4)		
	*Requires <b>X</b> for Monitor Signal (#4)		
<b>4</b>	<b>Output Signal Range</b>		
<b>X</b>	No Monitor		
<b>E</b>	0 to 10 VDC		
<b>K</b>	0 to 5 VDC*		
<b>V</b>	1 to 5 VDC* <sup>1</sup>		
<b>C</b>	4 to 20 mA DC (Sinking)		
<b>S</b>	4 to 20 mA DC (Sourcing)		
	*Requires <b>E, I or K</b> for Input Signal Range (#3)		
	*Requires <b>V</b> for Input Signal Range (#3)		
<b>5</b>	<b>Zero Offset</b>		
<b>P</b>	0% Pressure is Above Zero		
<b>Z</b>	0% Pressure is Zero (Typical)		
<b>6</b>	<b>Zero Offset Pressure</b>		
	Typical is 0* - If greater than 30% of full scale pressure (#8 below), please consult factory.		
	*If <b>Z</b> for Zero Offset, Please Leave this Section (#6) Blank		
<b>7</b>	<b>Full Scale Pressure Type</b>		
<b>P</b>	100% Pressure is Above Zero		
<b>Z</b>	100% Pressure is Zero		
<b>8</b>	<b>Full Scale Pressure</b>		
	Must be less than or equal to 125 psig		
<b>09</b>	<b>Pressure Unit (no additional fee - all)</b>		
<b>PS</b>	PSI	Inches Hg	<b>IH</b>
<b>MB</b>	Millibars	Inches H <sub>2</sub> O	<b>IW</b>
<b>BR</b>	Bar	Millimeters H <sub>2</sub> O	<b>MW</b>
<b>KP</b>	Kilo-pascal	Kilograms/cm <sup>2</sup>	<b>KG</b>
<b>MP</b>	Mega-pascal	Torr (Requires A for Unit of Measure #11)	<b>TR</b>
<b>MH</b>	Millimeters Hg	Centimeters H <sub>2</sub> O	<b>CW</b>
<b>PA</b>	Pascal		
<b>10</b>	<b>Pressure Unit of Measure</b>		
<b>G</b>	Gauge Pressure		

**TABLE 1**

<b>MAX. calibrated pressure:</b>	<b>Max. inlet pressure:</b>
5 Through 10 PSIG Positive	15 PSIG (1 Bar)
10.1 up to 30 PSIG (0.70 up to 2 Bar)	35 PSIG (2.4 Bar)
31 up to 100 PSIG (2.1 up to 7 Bar)	110 PSIG (7.6 Bar)
101 up to 150 PSIG (7 up to 10.3 Bar)	165 PSIG (11.4 Bar)

# Safety Precautions



Please read all of the following Safety Precautions before installing or operating any Proportion-Air, Inc. equipment or accessories. To confirm safety, be sure to observe 'ISO 4414: Pneumatic Fluid Power - General rules relating to systems' and other safety practices.



## Warning

Improper operation could result in serious injury to persons or loss of life!

- PRODUCT COMPATIBILITY**  
Proportion-Air, Inc. products and accessories are for use in industrial pneumatic applications with compressed air media. The compatibility of the equipment is the responsibility of the end user. Product performance and safety are the responsibility of the person who determined the compatibility of the system. Also, this person is responsible for continuously reviewing the suitability of the products specified for the system, referencing the latest catalog, installation manual, Safety Precautions and all materials related to the product.
- EMERGENCY SHUTOFF**  
Proportion-Air, Inc. products cannot be used as an emergency shutoff. A redundant safety system should be installed in the system to prevent serious injury or loss of life.
- EXPLOSIVE ATMOSPHERES**  
Products and equipment should not be used where harmful, corrosive or explosive materials or gases are present. Unless certified, Proportion-Air, Inc. products cannot be used with flammable gases or in hazardous environments.
- AIR QUALITY**  
Clean, dry air is not required for Proportion-Air, Inc. products. However, a 40 micron particulate filter is recommended to prevent solid contamination from entering the product.
- TEMPERATURE**  
Products should be used with a media and ambient environment inside of the specified temperature range of 32°F to 158°F. Consult factory for expanded temperature ranges.
- OPERATION**  
Only trained and certified personnel should operate electronic and pneumatic machinery and equipment. Electronics and pneumatics are very dangerous when handled incorrectly. All industry standard safety guidelines should be observed.
- SERVICE AND MAINTENANCE**  
Service and maintenance of machinery and equipment should only be handled by trained and experienced operators. Inspection should only be performed after safety has been confirmed. Ensure all supply pressure has been exhausted and residual energy (compressed gas, springs, gravity, etc.) has been released in the entire system prior to removing equipment for service or maintenance.



## Caution

Improper operation could result in serious injury to persons or damages to equipment!

- PNEUMATIC CONNECTION**  
All pipes, pneumatic hose and tubing should be free of all contamination, debris and chips prior to installation. Flush pipes with compressed air to remove any loose particles.
- THREAD SEALANT**  
To prevent product contamination, thread tape is not recommended. Instead, a non-migrating thread sealant is recommended for installation. Apply sealant a couple threads from the end of the pipe thread to prevent contamination.
- ELECTRICAL CONNECTION**  
To prevent electronic damage, all electrical specifications should be reviewed and all electrical connections should be verified prior to operation.

## Exemption from Liability

- Proportion-Air, Inc.** is exempted from any damages resulting from any operations not contained within the catalogs and/or instruction manuals and operations outside the range of its product specifications.
- Proportion-Air, Inc.** is exempted from any damage or loss whatsoever caused by malfunctions of its products when combined with other devices or software.
- Proportion-Air, Inc.** and its employees shall be exempted from any damage or loss resulting from earthquakes, fire, third person actions, accidents, intentional or unintentional operator error, product misapplication or irregular operating conditions.
- Proportion-Air, Inc.** and its employees shall be exempted from any damage or loss, either direct or indirect, including consequential damage or loss, claims, proceedings, demands, costs, expenses, judgments, awards, loss of profits or loss of chance and any other liability whatsoever including legal expenses and costs, which may be suffered or incurred, whether in tort (including negligence), contract, breach of statutory duty, equity or otherwise.

## Warranty

Proportion-Air, Inc. products are warranted to the original purchaser only against defects in material or workmanship for one (1) year from the date of manufacture. The extent of Proportion-Air's liability under this warranty is limited to repair or replacement of the defective unit at Proportion-Air's option. Proportion-Air shall have no liability under this warranty where improper installation or filtration occurred.