

SERVOTOUGH FluegasExact 2700

HIGH PERFORMANCE COMBUSTION PROCESS ANALYSIS OF OXYGEN AND COMBUSTIBLES,
DESIGNED FOR USE IN THE MOST HAZARDOUS AND CHALLENGING LOCATIONS



SERVOTOUGH FluegasExact 2700



Armed with an integral sampling system custom-designed for operation in some of the hottest and most extreme combustion environments, the FluegasExact is the analyser of choice for measuring oxygen and combustibles in the most demanding hydrocarbon processing and power generation applications.

Designed for high temperature processes up to 1750°C (3182°F), the FluegasExact is ideal for use in extreme heated environments. This resilience makes it the analyser of choice for controlling a wide range of combustion processes, including use in process heaters, utility boilers, thermal crackers, incinerators and furnaces.

FLEXIBLE

- Designed for Safe Area, Zone 2/Division 2 and ATEX Cat. 3 hazardous area rated locations
- Robust O₂ and COe analysis meets diverse application needs
- Intelligent sampling options for exact fit
- Performs in high temperature/high particulate environments

EASY TO USE

- Easy to maintain in the field
- Intelligent Flowcube technology provides continuous flow monitoring for preventative maintenance

LOW COST OF OWNERSHIP

- Simple installation and low maintenance requirements
- Extractive sampling design protects from harsh process conditions, extending product life
- Long life, low-drift sensing technologies for reliability and extended calibration intervals
- Intelligent design that extends maintenance intervals and permits field service

UNRIVALLED PERFORMANCE

- Uses industry-leading patented technologies (Zirconia cell and Thick Film Catalytic sensor) for ultra-accurate and reliable measurements
- Manufactured by Servomex - over 60 years' experience in pioneering gas analysis, with a global install base

BENCHMARK COMPLIANCE

- ATEX Cat. 3, IECEx Zone 2 & North America Class I, Div. 2

Learn more about the SERVOTOUGH FluegasExact 2700
VISIT SERVOMEX.COM



SERVOMEX.COM

PRODUCT OVERVIEW: FluegasExact 2700

UNBEATABLE PERFORMANCE IN THE MOST CHALLENGING LOCATIONS

When you work in combustion analysis applications where high temperatures and particulates/dusts are occupational hazards, you need a gas analysis solution that offers rugged durability and unrivalled performance. Using a robust, fully heated stainless steel design, the FluegasExact is certified for Zone 2/Division 2 monitoring. High temperature and flow sensor options further extend operational performance.

A NO COMPROMISE SOLUTION

At the heart of the SERVOTOUGH FluegasExact's exceptional performance are Servomex's patented Zirconium Oxide cell for oxygen measurement and a Thick Film catalytic sensor for measuring carbon monoxide and COe (combustibles). Combined, the performance of both technologies improves process control and helps reduce excess oxygen, reducing NOx, SO₃ and CO emissions and has been proven to save up to four percent of fuel costs per year.

Both sensors are installed within Servomex's custom-designed heated sensor head, which has a low-flow extractive design that can attach directly to the flue or can be remote mounted. Manufactured to the highest quality standards, this ensures exceptional performance in the toughest environments and with the minimum of maintenance.

UNBEATABLE VALUE OVER PRODUCT LIFE

The ability to reduce ongoing maintenance costs and minimize long-term ownership costs is essential, while operational benefits like simple installation requirements are highly attractive. Supported by Servomex's global service network, which offers a complete package of support from commissioning to servicing, the FluegasExact delivers a long life of exceptional performance.

ALTERNATIVE PRODUCTS

The SERVOTOUGH product range features analyzers designed to meet your application needs:

LaserSP 2930



A cross-stack TDL monitor designed for in-situ process measurement, the LaserSP offer multigas monitoring across high temperature, high particulate environments including ovens and furnaces.

KEY APPLICATIONS

- Process heaters
- Utility boilers
- Thermal crackers
- Crematoria
- Iron & steel
- Incinerators
- Biomass boilers



PRODUCT DATA: FluegasExact 2700

OPTIONS	DESCRIPTION	SPECIFICATION
Analog output	2 x configurable, isolated 4-20mA outputs (one for each measurement) as standard	Recommended impedance 600Ω or less, 1kΩ max.
Alarms and relays	4 x relays	4 x SPCO relays (250V ac/3A or 28V dc/1A max.), configurable for: concentration alarms, faults, in calibration, in blowback and solenoid valves for blowback and auto-calibration
Digital inputs	Simplify maintenance with remote validation capabilities	2 x non isolated digital inputs for auto-calibration and blowback
Power supply	Options for control unit and sensor head	Voltage: 100-120V/50/60Hz or 220-240V ac/50/60Hz Rated power: 250VA (control unit), 600VA (sensor head)
Control unit	Feature-rich	8 button keypad, intuitive interactions and backlit LCD
Measurements	Dual or single gas	Can be supplied as O ₂ or COe only if required
Sample probes	Various options for simplified sample acquisition	Open ended probes in stainless steel, high temperature alloy and ceramic for low dust loading. Filtered probes for high dust load samples

ACCESSORIES

ACCESSORIES AVAILABLE FOR SPECIFIC APPLICATIONS – CONTACT YOUR LOCAL SERVOMEX BUSINESS CENTER

MEASUREMENT PERFORMANCE

Gas	O ₂	COe (high sensitivity)**	COe (sulfur resistant)**
Technology	Zirconium oxide (zirconia)	Thick film catalytic	Thick film catalytic
Accuracy (intrinsic error)	±1% reading or 0.1% O ₂ *	±25ppm or ±5% reading*	±75ppm or ±5% reading*
Repeatability	<0.1% O ₂	±25ppm or ±5% reading*	±50ppm or ±5% reading*
Zero drift	<0-5% of range or 0.05% O ₂ per 3 months	<25ppm/week	<35ppm/week
T ₉₀ (not including probes)	<10s	<20s	<20s
Operating temp. (sensor head)		-20 to +70°C (-4 to +158°F)	
Working range	0-25%	0-6,000ppm	0-6,000ppm

SAMPLE WETTED MATERIALS

Sensor head	Stainless steel (303 and 316), gasket sealing material (Klinger grade SLS 150)
Oxygen sensor	Stainless steel (310 and 316), zirconia, platinum, alumina, Ni/Fe/Cr alloy, high temperature sealing glasses
Combustibles sensor	Stainless steel (316), platinum, platinum/iridium, zirconia, alumina, corrosive resistant glass
Flow cube	Stainless steel (316), zirconia, platinum/iridium, corrosion resistant glass

* Whichever is greater

** The COe measurement is not promoted or recommended for use as a primary safety measurement, e.g. in electrostatic precipitators (ESP) or coal mill applications

PRODUCT DATA: FluegasExact 2700

DEVICE SPECIFICATION

Size:

- Control unit: 391 x 167 x 260mm (15.4" x 6.6" x 10.3")
- Sensor head: 301 x 330 x 256mm (11.9" x 13.0" x 10.1")
- Flow alarm relay box: 120 x 120 x 80mm (4.7" x 4.7" x 3.1")

Weight:

- 30.5kg (67.2 lbs) (Combined weight)

Certifications:

- ATEX Cat. 3
- IECEx Zone 2
- North America Class I, Div. 2
- CE marked and in compliance with ATEX / IECEx, EMC and WEEE Directives scope. All variants comply with BS EN 61010

DEVICE SCHEMATIC

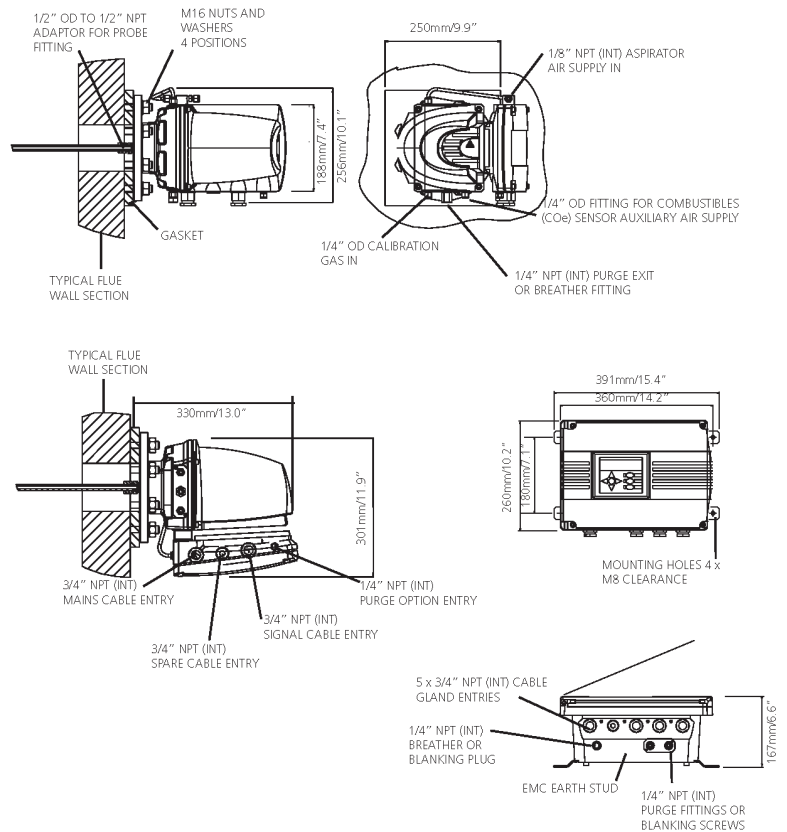

These analyzers are not intended for any form of use on humans and are not medical devices as described in the Medical Devices Directive 93/42EEC.

Please note: This document was updated in August 2014. While every effort has been made to ensure accuracy, no responsibility can be accepted for errors or omissions. Data may change, as well as legislation, and you are strongly advised to obtain copies of the most recently issued regulations, standards and guidelines. This document is not intended to form the basis of a contract.

AMERICAS BUSINESS CENTER
Tel: +1 281 295 5800
Email: americas_sales@servomex.com

ASIA PACIFIC BUSINESS CENTRE
Tel: +86 (0)21 6489 7570
Email: asia_sales@servomex.com

EUROPEAN BUSINESS CENTRE
Tel: +31 (0) 79 330 1580
Email: europe_sales@servomex.com

INDIA BUSINESS CENTRE
Tel: +91 22 3934 2700
Email: MEI_sales@servomex.com

MIDDLE EAST BUSINESS CENTRE
Tel: +971 6552 8073
Email: MEI_sales@servomex.com

SERVOMEX.COM

Servomex has a policy of constant product improvement and reserves the right to change specifications without notice.
© Servomex Group Limited. 2014. A Spectris company. All rights reserved.

SERVOMEX