





Vibrating filling level switch with extension tube

- For universal applications such as filling level detection or dry run protection system
- Installation without adjustment
- Ideal for the food, beverage and pharmaceutical industry with a surface roughness < 0.8 µm
- ATEX approvals

Product variants described in the data sheet may differ from the product presentation and description.

Can be combined with

| | | |
|---|--|---|
|  | Type 2030 2/2-way diaphragm valve with pneumatic plastic actuator (Type CLASSIC) | ▶ |
|  | Type 8644 AirLINE SP electropneumatic automation system | ▶ |
|  | Type 2301 Pneumatically operated 2-way Globe Control Valve | ▶ |
|  | Type 8619 multiCELL – multi-channel/multi-function transmitter/controller | ▶ |

Type description

The Type 8112 is a filling level switch for liquids, using a tuning fork as the sensor element.

It is designed for industrial use in areas of process technology and can be used in liquids. Typical applications are overflow or dry run protection.

The Type 8112 is available with different sensor lengths. The immersion depth can be adapted thanks to a lock fitting.

Due to the simple and rugged measuring system, the Type 8112 is virtually unaffected by the chemical and physical features of the liquid. It works even under unfavourable conditions such as turbulence, air bubbles, foam generation (not suitable for measuring the foam thickness itself), adhesions, strong external vibrations or varying filling materials.

DTS 1000086888 EN Version: R Status: RL (released | freigegeben | valide) printed: 08.08.2025

Table of contents

| | |
|--|----------|
| 1. General technical data | 3 |
| 1.1. About the device..... | 3 |
| 1.2. All variants..... | 3 |
| 1.3. Vibrating level switch with relay output..... | 4 |
| 1.4. Vibrating level switch with NAMUR output..... | 4 |
| 2. Approvals and conformities | 5 |
| 2.1. General notes..... | 5 |
| 2.2. Conformity..... | 5 |
| 2.3. Standards..... | 5 |
| 2.4. Explosion protection..... | 5 |
| 3. Materials | 5 |
| 3.1. Bürkert resistApp..... | 5 |
| 3.2. Material specifications..... | 6 |
| 4. Dimensions | 6 |
| 4.1. G ¾" or NPT ¾" connection..... | 6 |
| 4.2. G 1" or NPT 1" connection..... | 7 |
| 4.3. Clamp 2" connection..... | 7 |
| 5. Performance specifications | 8 |
| 5.1. Temperature derating diagram..... | 8 |
| 6. Product installation | 8 |
| 6.1. Installation notes..... | 8 |
| 7. Product operation | 9 |
| 7.1. Measuring principle..... | 9 |
| 8. Product accessories | 9 |
| 9. Ordering information | 9 |
| 9.1. Bürkert eShop..... | 9 |
| 9.2. Bürkert product filter..... | 10 |
| 9.3. Ordering chart..... | 10 |
| 9.4. Ordering chart accessories..... | 11 |

1. General technical data

1.1. About the device

The vibrating level switch is available with double relay output or with NAMUR output. The technical data depends on the vibrating level switch variant.

1.2. All variants

Product properties

Material

Make sure the device materials are compatible with the fluid you are using.
Further information can be found in chapter [“3.1. Bürkert resistApp” on page 5.](#)

Further information on the materials can be found in chapter [“3.2. Material specifications” on page 6](#)

| | |
|-------------------|--|
| Surface quality | Ra < 3.2 µm (thread) / Ra < 0.8 µm (clamp) |
| Dimensions | Further information can be found in chapter “4. Dimensions” on page 6. |
| Weight | Approx. 850 g + approx. 920 g/m (extension tube) |
| Probe length | 200...1000 mm (including the extension tube Ø 21.3) |
| Measured variable | Limit level of liquids |

Performance data

| | |
|-----------------------|---|
| Measurement deviation | ± 1 mm |
| Repeatability | 0.1 mm |
| Hysteresis | Approx. 2 mm with vertical installation |
| Switching delay | Approx. 500 ms (On/Off) |

Electrical data

| | |
|---|--|
| Power source (not supplied) | Limited power source according to UL/EN 62368-1 standards or limited energy circuit according to UL/EN 61010-1 paragraph 9.4 |
| Overvoltage category according to IEC 61010-1 | Category III |
| Resonance frequency | Approx. 1200 Hz |

Medium data

| | |
|--------------------------|--|
| Process temperature | - 50...+ 150 °C (- 58...+ 302 °F) |
| Process pressure | - 1...64 bar/- 100...6400 kPa (- 14.51...+ 928.64 PSI) |
| Dynamic viscosity η | 0.1...10000 mPa.s (requirement: with density 1) |
| Density | Selected by DIP switch: <ul style="list-style-type: none"> • Standard sensitivity: 0.7...2.5 g/cm³ • High sensitivity: 0.5...2.5 g/cm³ |
| Flow velocity | Max. 6 m/s (with a viscosity of 10000 mPa.s) |

Product connections

| | |
|--------------------|-------------------------------------|
| Process connection | Thread G or NPT, ¾" or 1"; clamp 2" |
|--------------------|-------------------------------------|

Approvals and conformities

Directives

| | |
|----------------------|--|
| CE directive | Further information on the CE Directive can be found in chapter “2.3. Standards” on page 5 |
| NAMUR recommendation | IEC 60947-5- 6 (EN 50227) |
| Explosion protection | ATEX: EN 60079-0, EN 60079-11, EN 60079-26 Further information can be found in chapter “2.4. Explosion protection” on page 5. |

Environment and installation

| | |
|--|---|
| Ambient temperature | <ul style="list-style-type: none"> • Operating on the housing: - 40...+ 70 °C (- 40...+ 158 °F) • Storage and transport: - 40...+ 80 °C (- 40...+ 176 °F) |
| Temperature derating | Further information can be found in chapter “5.1. Temperature derating diagram” on page 8. |
| Relative air humidity | 20...85 %, without condensation |
| Degree of protection according to IEC/EN 60529 | IP66/IP67 with M20 × 1.5 gland mounted and tightened |

1.3. Vibrating level switch with relay output

| Product properties | |
|---|---|
| Operating mode | Adjustable <ul style="list-style-type: none"> • A = max. detection or overflow/overflow protection • B = min. detection or dry run protection |
| Electrical data | |
| Operating voltage | 20...253 V AC, 50/60 Hz or 20...72 V DC (at U > 60 V DC the ambient temperature must be max. + 50 °C (+ 122 °F)) |
| Protection class according to IEC 61010-1 | I |
| Power consumption | 1...8 VA (AC); approx. 1.5 W (DC) |
| Switching voltage | Max. 253 V AC/DC |
| Switching current | Max. 3 A (AC, cos phi > 0.9), 1 A (DC) |
| Breaking power | <ul style="list-style-type: none"> • Min. 50 mW • Max. 750 VA AC, 40 W DC (with U < 40 V DC) |
| Output | Relay (DPDT), 2 floating SPDTs |
| Product connections | |
| Electrical connection | 2 cable glands M20 × 1.5 |

1.4. Vibrating level switch with NAMUR output

| Product properties | |
|---|---|
| Operating mode | NAMUR output adjustable to falling or rising characteristics <ul style="list-style-type: none"> • Min.: Rising characteristics (High current when wetted with liquid) • Max.: Falling characteristics (Low current when wetted with liquid) |
| Electrical data | |
| Operating voltage | <ul style="list-style-type: none"> • Voltage supply: via connection to an amplifier according to NAMUR IEC 60947-5-6, approx. 8.2 V • Open-circuit voltage: U_0 approx. 8.2 V • Short-circuit current: I_0 approx. 8.2 mA |
| Protection class according to IEC 61010-1 | II |
| Current consumption | <ul style="list-style-type: none"> • Falling characteristic: ≥ 2.2 mA (blade uncovered) / ≤ 1.0 mA (blade covered) • Rising characteristic: ≤ 1.0 mA (blade uncovered) / ≥ 2.2 mA (blade covered) • Fault signal: ≤ 1.0 mA |
| Output | 2-wire current modulation according to NAMUR |
| Product connections | |
| Electrical connection | 1 cable gland M20 × 1.5 |
| Necessary processing system | NAMUR processing system according to IEC 60947-5-6 (EN 50227/DIN 19234) |

2. Approvals and conformities

2.1. General notes

- The approvals and conformities listed below must be stated when making enquiries. This is the only way to ensure that the product complies with all required specifications.
- Not all available variants of the device can be supplied with the below mentioned approvals or conformities.

2.2. Conformity

In accordance with the Declaration of Conformity, the product is compliant with the EU Directives.

2.3. Standards

The applied standards which are used to demonstrate compliance with the EU Directives are listed in the EU-Type Examination Certificate and/or the EU Declaration of Conformity.

2.4. Explosion protection

| Approval | Description |
|----------|---|
| | <p>Optional: Explosion protection Ex marking of the components according to:</p> <p>ATEX: PTB 07 ATEX 2004X</p> <ul style="list-style-type: none"> • II 1/2G Ex ia IIC T6 Ga/Gb • II 2G Ex ia IIC T6 Gb <p>Measures for compliance with ATEX/IECEx requirements: see Additional manual/Supplement ATEX/IECEx Type 8112 ▶ under “User manuals”. The Ex. certification is only valid if the Bürkert device is used as described in the additional manual/supplement. Any unauthorized modifications made to the device will invalidate the Ex certification.</p> |

3. Materials

3.1. Bürkert resistApp

Bürkert resistApp – Chemical resistance chart

You want to ensure the reliability and durability of the materials in your individual application case? Verify your combination of media and materials on our website or in our resistApp.

Start chemical resistance check

DTS 1000086888 EN Version: R Status: RL (released | freigegeben | valide) printed: 08.08.2025

3.2. Material specifications

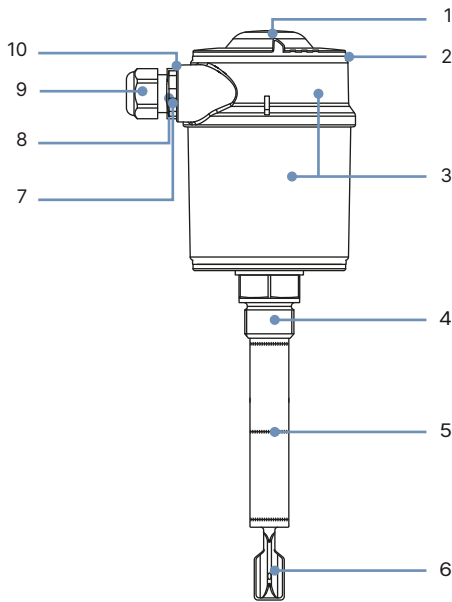

| No. | Element | Material |
|-----|--|--|
| 1 | Cover | PC |
| 2 | Seal between housing and housing cover | EPDM |
| 3 | Housing | Plastic PBT (Polyester), PPS and stainless steel 316L (1.4404) |
| 4 | Process connection | Stainless steel 316L (1.4435) |
| 5 | Extension tube | Stainless steel 316L (1.4435) |
| 6 | Tuning fork | Stainless steel 316L (1.4435) |
| 7 | Blind plug | PA |
| 8 | Ground terminal | Stainless steel 316L |
| 9 | Cable gland | PA |
| 10 | Cable gland seal | NBR |
| | Process seal (not shown) | NBR with aramid fibers |

4. Dimensions

4.1. G 3/4" or NPT 3/4" connection

Note:

Dimensions in mm, unless otherwise stated

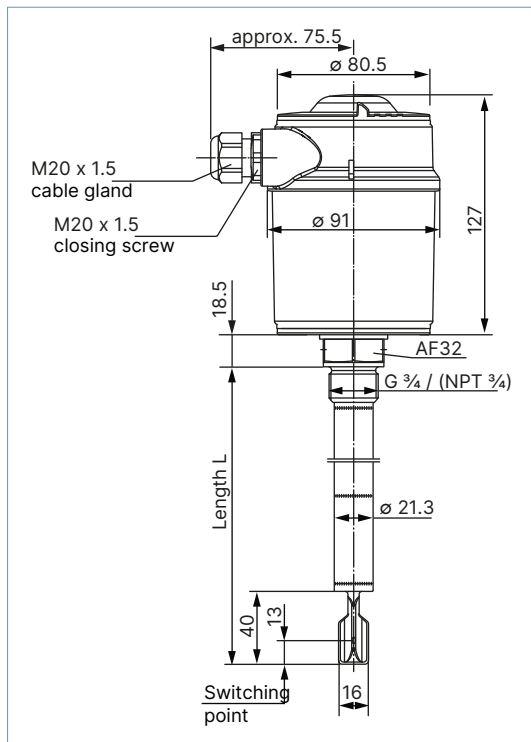

| Length L |
|----------|
| 300 |
| 500 |
| 1000 |

DTS 1000086888 EN Version: R Status: RL (released | freigegeben | valide) printed: 08.08.2025

4.2. G 1" or NPT 1" connection

Note:

Dimensions in mm, unless otherwise stated

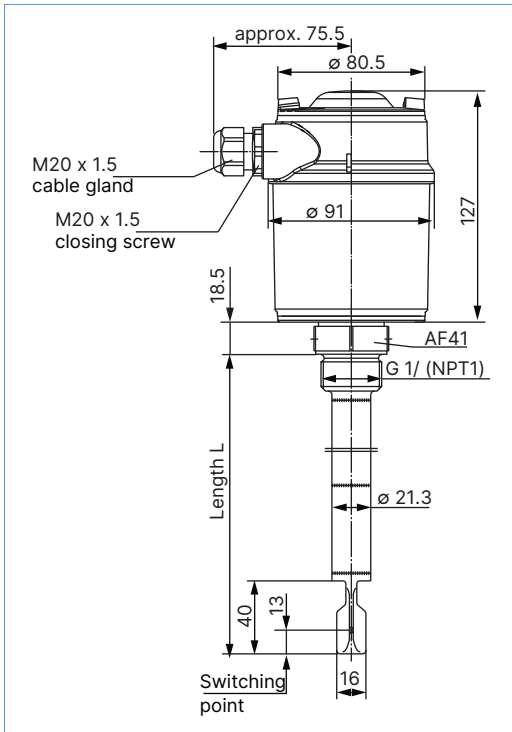

| Length L |
|----------|
| 300 |
| 500 |
| 1000 |

4.3. Clamp 2" connection

Note:

Dimensions in mm, unless otherwise stated

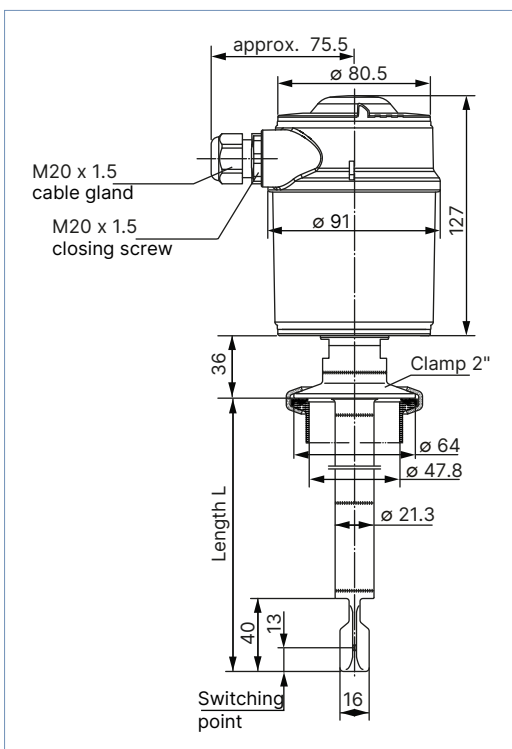

| Length L |
|----------|
| 300 |
| 500 |
| 1000 |

DTS 1000086888 EN Version: R Status: RL (released | freigegeben | valide) printed: 08.08.2025

5. Performance specifications

5.1. Temperature derating diagram

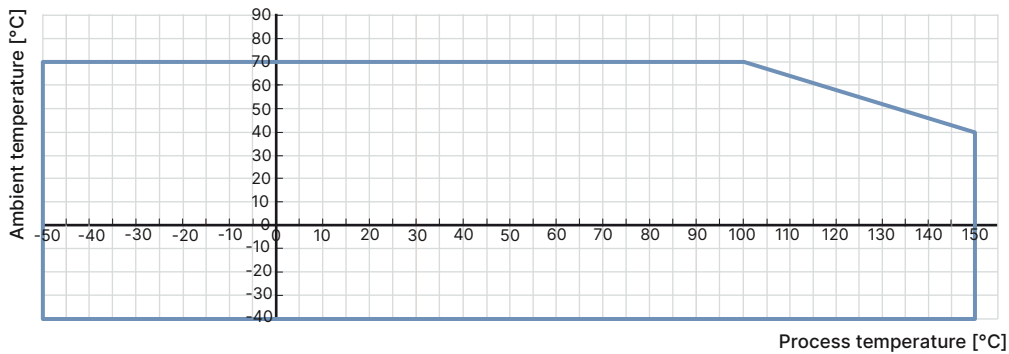

6. Product installation

6.1. Installation notes

The vibrating level switch Type 8112 can be installed in any position. The instrument only has to be mounted in such a way that the tuning fork is at the height of the desired switching point.

The tuning fork has lateral markings (notches) that indicate the switching point with vertical mounting. The switching point refers to water with the basic setting of the sensitivity switch $\geq 0.7 \text{ g/cm}^3$.

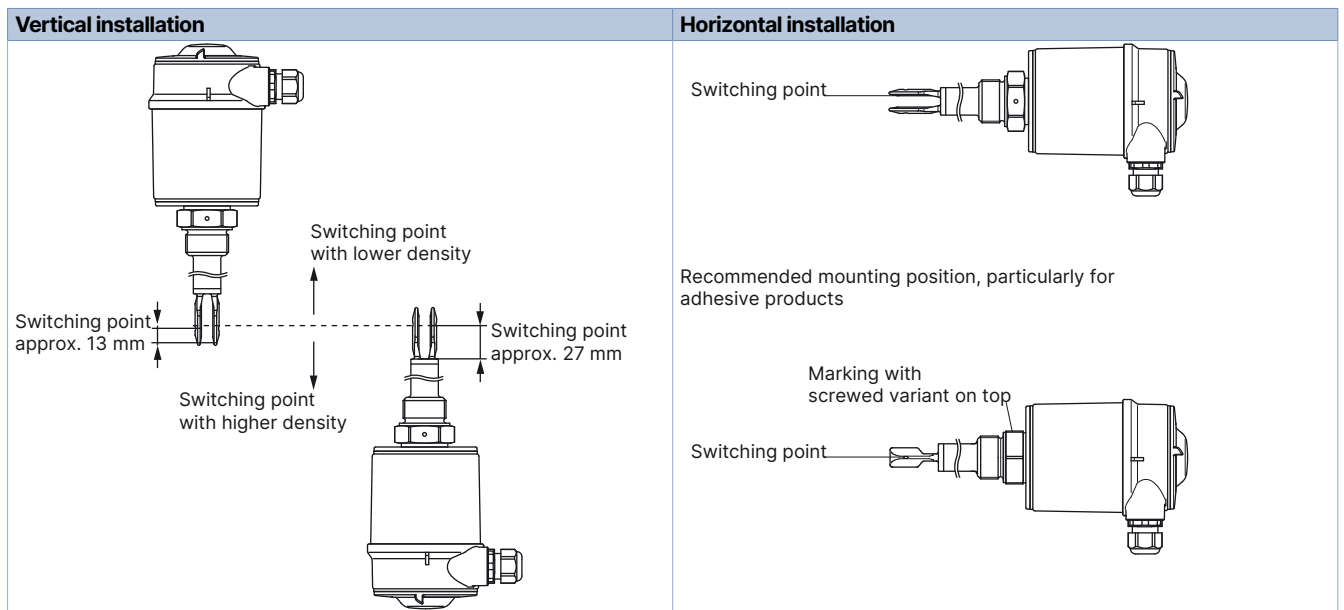

DTS 1000086888 EN Version: R Status: RL (released | freigegeben | valide) printed: 08.08.2025

7. Product operation

7.1. Measuring principle

The tuning fork is piezoelectrically energised and vibrates at a mechanical resonance frequency of approx. 1200 Hz. When the tuning fork is submerged in the product, the frequency changes. This change is detected by the integrated oscillator and converted into a switching command.

The integrated fault monitor detects the following faults:

- Interruption of the connection cable to the piezoelectric elements
- Extreme material wear on the tuning fork
- Breakage of the tuning fork
- Absence of vibration.

If one of these faults is detected or in case the power supply fails, the electronic system switches to a defined switching state, e.g. the relay de-energises (safe state).

8. Product accessories

Note:

The accessories must be ordered separately, see chapter “9.4. Ordering chart accessories” on page 11.

| Accessory | Description |
|--|---|
| <p>Lock fitting</p> <p>Terminal screws (3 pcs.)</p> <p>Dimensions in mm, unless otherwise stated</p> <p>Ø 21.3mm</p> <p>35</p> <p>20</p> <p>AF41</p> <p>G1</p> <p>NPT1</p> | <p>The lock fitting is a threaded fitting and can be used together with the vibration level switch Type 8112. It must only be used in unpressurised vessels.</p> <p>The wetted parts of the lock fitting are made of stainless steel (316L).</p> <p>With the lock fittings, sensors with tube extension can be fixed infinitely. The terminal screws protect the tube against sliding through.</p> <p>The following variants are available: Ø 21.3 mm - G 1 or 1 NPT (AF 41)</p> |

9. Ordering information

9.1. Bürkert eShop



Bürkert eShop – Easy ordering and quick delivery

You want to find your desired Bürkert product or spare part quickly and order directly? Our online shop is available for you 24/7. Sign up and enjoy all the benefits.

[Order online now](#)

9.2. Bürkert product filter



Bürkert product filter – Get quickly to the right product

You want to select products comfortably based on your technical requirements? Use the Bürkert product filter and find suitable articles for your application quickly and easily.

Try out our product filter

9.3. Ordering chart



| Operating voltage | Process connection | Probe length ¹⁾ | Output | Electrical connection | Article no. | | | | |
|---------------------------------------|---|----------------------------|--|--------------------------|-------------|---|-------------------------|--------|--------|
| 20...72 V DC / 20...250 V AC (5 A) | G ¾" | 300 | Double relay (DPDT), 2 floating spdts | 2 cable glands M20 × 1.5 | 558119 | | | | |
| | NPT ¾" | | | | 558120 | | | | |
| | G ¾" | | | | 500 | 558121 | | | |
| | NPT ¾" | 558122 | | | | | | | |
| | G ¾" | 1000 | | | 558123 | | | | |
| | NPT ¾" | | | | 558124 | | | | |
| | G 1" | 300 | | | 558125 | | | | |
| | NPT 1" | | | | 558126 | | | | |
| | G 1" | | | | 500 | 558127 | | | |
| | NPT 1" | 558128 | | | | | | | |
| | G 1" | 1000 | | | 558129 | | | | |
| | NPT 1" | | | | 558130 | | | | |
| | 8.2 V DC, via an isolating amplifier with NAMUR input | Clamp 2" | | | 300 | Namur signal - Ex variant ATEX approval | 1 cable gland M20 × 1.5 | 558131 | |
| | | Clamp 2" | | | | | | 500 | 558132 |
| | | Clamp 2" | | | | | | 1000 | 558133 |
| G ¾" | | 300 | 558134 | | | | | | |
| G 1" | | | 558135 | | | | | | |
| G ¾" | | 500 | 558136 | | | | | | |
| G 1" | | | 558137 | | | | | | |
| G ¾" | | | 1000 | 558138 | | | | | |
| G 1" | | 558139 | | | | | | | |

1) Length of the extension tube Ø 21.3 included

| Further variants on request | |
|---|---|
| <p>Process connection</p> <ul style="list-style-type: none"> Clamp 1", 1½" DIN 11851 Flange SMS NEUMO BioControl® (a registered Trademark of NEUMO-Ehrenberg Group) | <p>Hygienic</p> <ul style="list-style-type: none"> Ra < 0.8 µm for G or NPT threaded connection Ra < 0.3 µm for Clamp connection |
| <p>Material</p> <p>ECTFE, enamel, Alloy C4 or PFA for flange connection</p> | <p>Temperature</p> <p>- 50...+ 250 °C</p> |
| <p>Additional</p> <ul style="list-style-type: none"> Up to 6000 mm With transistor output | |

DTS 1000086888 EN Version: R Status: RL (released | freigegeben | valide) printed: 08.08.2025

9.4. Ordering chart accessories

| Description | Article no. |
|--|--|
| Set with two adapters M20 × 1.5 /NPT ½", two neoprene flat seals for cable gland or plug and two screw plugs M20 × 1.5 | 551782  |
| Lock fitting, only for pressureless handling, - 50...150 °C, G 1" | 558218  |
| Lock fitting, only for pressureless handling, - 50...150 °C, NPT 1" | 558219  |