

Type 8700 / 8701 / 8703 / 8705
MFM, Mass Flow Meter IP40

Type 8710 / 8711 / 8713 / 8715
MFC, Mass Flow Controller IP40

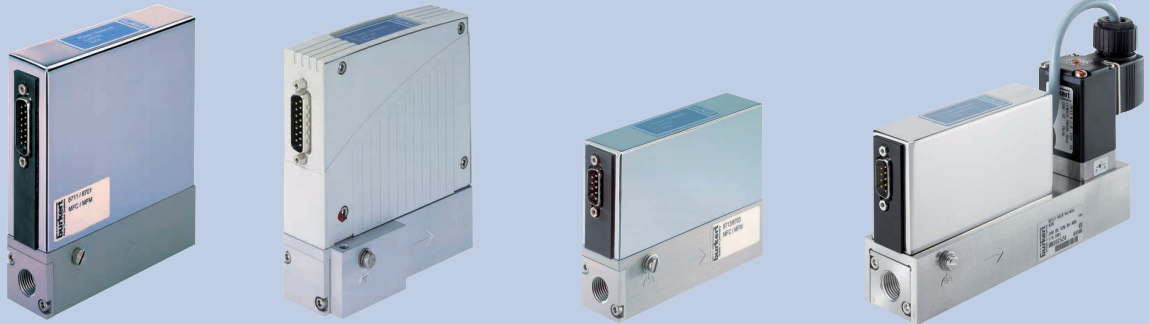

Operating Instructions

Bedienungsanleitung
Manuel d'utilisation

We reserve the right to make technical changes without notice.
Technische Änderungen vorbehalten.
Sous réserve de modifications techniques.

© Bürkert SAS 2013–2022

Operating Instructions 2211/02_EU-ML 00563582 / Original EN

1	ABOUT THESE OPERATING INSTRUCTIONS	5	7	INSTALLATION AND COMMISSIONING	19
1.1	Symbols used	5	7.1	Safety instructions	19
1.2	Definition of the word "device"	5	7.2	Prior to installation	20
2	INTENDED USE	6	7.3	Sequence of the steps to be performed	20
3	BASIC SAFETY INFORMATION.....	6	7.4	Setting the parameters	20
4	GENERAL INFORMATION	8	7.5	Mechanical installation.....	24
4.1	Manufacturer's address and international contacts ...	8	7.6	Fluid installation.....	24
4.2	Warranty conditions	8	7.7	Electrical installation	26
4.3	Information on the Internet	8	8	OPERATION AND FUNCTION	27
5	DESCRIPTION OF THE DEVICE	8	8.1	Safety instructions	27
5.1	General description	8	8.2	Operation of the MFM / MFC	27
5.2	Construction of the MFM / MFC	9	8.3	MFC operating modes	32
5.3	Operation of an MFM or MFC sensor	10	9	MAINTENANCE, TROUBLESHOOTING	36
5.4	Detailed operation of an MFC	10	9.1	Safety instructions	36
6	TECHNICAL DATA.....	12	9.2	Maintenance	36
6.1	Standards and directives.....	12	9.3	If you encounter problems	38
6.2	Certifications	12	10	ACCESSORIES / SPARE PARTS	41
6.3	Operating conditions.....	13	10.1	Accessories	41
6.4	Mechanical data	13	10.2	Spare part	43
6.5	Dimensions	13	11	SHUTDOWN	44
6.6	Fluidic data	14	11.1	Safety instructions	44
6.7	Electrical data	16	11.2	Dismounting of the MFM / MFC.....	44
6.8	Markings	18	12	PACKAGING, STORAGE, TRANSPORT	45
			12.1	Packaging, Transport	45
			12.2	Storage.....	45

13 RETURNING THE DEVICE 46

14 DISPOSAL OF THE DEVICE 46

1 ABOUT THESE OPERATING INSTRUCTIONS

The Operating Instructions describe the entire life cycle of the device. Please keep the Operating Instructions in a safe place, accessible to all users and any new owners.

The Operating Instructions contain important safety information.

Failure to comply with these instructions can lead to hazardous situations.

- ▶ Whatever the version of the product, the Operating Instructions must be read and understood.
- ▶ When the symbol  is marked inside or outside the product, carefully read the Operating Instructions.

1.1 Symbols used



DANGER

Warns against an imminent danger.

- ▶ Failure to observe this warning results in death or in serious injury.



WARNING

Warns against a potentially dangerous situation.

- ▶ Failure to observe this warning can result in serious injury or even death.



CAUTION

Warns against a possible risk.

- ▶ Failure to observe this warning can result in substantial or minor injuries.

NOTE

Warns against material damage.



Indicates additional information, advice or important recommendations.



Refers to information contained in these Operating Instructions or in other documents.

- ▶ Indicates an instruction to be carried out to avoid a danger, a warning or a possible risk.
- Indicates a procedure to be carried out.
- ✔ Indicates the result of a specific instruction.

1.2 Definition of the word "device"

The word "device" used within these Operating Instructions refers to:

- a Mass Flow Meter (MFM) type 8700, 8701, 8703 or 8705,
- or a Mass Flow Controller (MFC) type 8710, 8711, 8713 or 8715.

2 INTENDED USE

Improper use of the device may be a hazard to people, nearby equipment and the environment.

MFM type 8700 / 8701 / 8703 / 8705 is used exclusively to measure the mass flow of clean dry gases.

MFC type 8710 / 8711 / 8713 / 8715 is used exclusively to control the mass flow of clean dry gases.

- ▶ Observe the additional data, operating and service conditions specified in the contract documents, the Operating Instructions and on the name plate and calibration plate.

The device:

- ▶ Use only for the media indicated on the name plate and in the calibration protocol.
- ▶ only use indoors.
- ▶ only use up to an altitude of 2000 m.
- ▶ Use only in conjunction with external instruments and components recommended by Bürkert.
- ▶ Operate carefully and ensure regular, professional maintenance.
- ▶ Operate only in perfect working order and ensure appropriate storage, transport, installation and control.
- ▶ Use only for its intended purpose.

3 BASIC SAFETY INFORMATION

This safety information does not take into account any contingencies or occurrences that may arise during installation, use and maintenance of the product.

The operating company is responsible for the respect of the local safety regulations including for the staff safety.



Danger due to high pressure in the installation/device.

- ▶ Before working on the installation or device, cut the pressure and vent and drain the pipes.

Risk of injury from electric shocks.

- ▶ Before working on the installation or device, switch off the power and ensure that it cannot be reactivated.
- ▶ Observe the applicable accident protection and safety regulations for electrical equipment!

Burns/fire hazard due to hot surface of the device!

- ▶ Keep the device away from any highly flammable materials or media and avoid any contact with bare hands.

Danger due to escape of the medium.

- ▶ Observe the applicable accident protection and safety regulations relating to the operating medium used.

Various dangerous situations.

To avoid personal injury, take care:

- ▶ Not to operate the device without the factory installed input filters.
- ▶ Only to operate the device in the installation position given on the calibration plate.
- ▶ That the operating pressure of the device is not higher than the maximum calibration pressure (MFM) specified on the calibration plate or the tightness pressure of the proportional valve (MFC).
- ▶ Only to use the device for the medium specified as the operating medium in the calibration protocol.
- ▶ Only to use agents that are stable with the device materials for cleaning and decontamination. The compatibility chart can be found on our homepage: country.burkert.com. If any ambiguity please contact your local sales office
- ▶ Do not make any modifications to the device.
- ▶ Do not subject the device to mechanical loads.
- ▶ Protect the installation/device from accidental actuation.
- ▶ Only trained personnel may perform installation and maintenance work.
- ▶ After an interruption in the electrical and media supply, ensure a controlled restart of the process.
- ▶ Observe the general technical rules.

NOTE!

Components / assemblies at risk from electrostatic charges!

The device contains electronic components which are susceptible to electrostatic discharge (ESD). Contact with electrostatically charged persons or objects endangers these components. In the worst case, they will become defective immediately or will fail when energized.

- ▶ To minimise or even avoid all damage due to an electrostatic discharge, take all the precautions described in the EN 61340-5-1.
- ▶ Do not touch any of the live electrical components.

4 GENERAL INFORMATION

4.1 Manufacturer's address and international contacts

To contact the manufacturer of the product, use following address:

Bürkert SAS

Rue du Giessen

BP 21

F-67220 TRIEMBACH-AU-VAL

The addresses of our international sales offices are available on the internet at: country.burkert.com.

4.2 Warranty conditions

The condition governing the legal warranty is the conforming use of the product in observance of the operating conditions specified in these Operating Instructions.

4.3 Information on the Internet

You can find the Operating Instructions and technical data sheets regarding the device at: country.burkert.com.

5 DESCRIPTION OF THE DEVICE

5.1 General description

- Mass flow meter types MFM 8700, 8701, 8703 and 8705 are devices designed for measuring the mass flow-rate of clean, dry gases.
- Mass flow controller types MFC 8710, 8711, 8713 and 8715 are devices designed for controlling the mass flow-rate of clean, dry gases.

Type of the device		Type of sensor
MFM	8700	Capillary/Bypass channel
	8701	MEMS
	8703	MEMS
	8705	Capillary/Bypass channel
MFC	8710	Capillary/Bypass channel
	8711	MEMS
	8713	MEMS
	8715	Capillary/Bypass channel

5.1.1 General operation of the Mass Flow Meter (MFM)

The MFM integrates a sensor for measuring the flow-rate. The measured value for the mass flow-rate is transmitted to a remote device via an analogue or a digital output (field bus).

5.1.2 General operation of the Mass Flow Controller (MFC)

The MFC comprises:

- a sensor for measuring the mass flow-rate,
- control electronics,
- an actuating element: low-friction solenoid control valve with a high response sensitivity.

5.2 Construction of the MFM / MFC

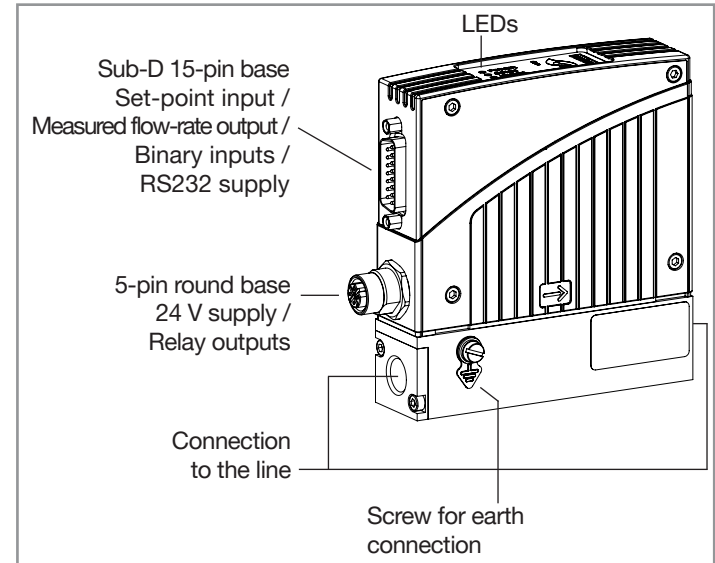

Fig. 1: Construction of the MFM / MFC (example of a 8700 / 8701 / 8710 / 8711 with 5-pin round base)

5.3 Operation of an MFM or MFC sensor

- The integrated flow-rate sensors use the thermal measurement process (anemometric and calorimetric) to measure the mass flow-rate. The main components are a heating resistor and a temperature probe. The gas which passes through the device modifies the temperature difference measured between both resistors.
- The thermal measurement principle allows the MFC to control the required mass flow-rate completely independently of the pressure and temperature fluctuations in the application concerned.



The damping of the output signal can be changed with the "Mass Flow Communicator" (see chapter [10.1.3](#)).



On the MFC types 8710, 8711, 8713, 8715, the technology for the integrated sensor requires filters to be fitted upstream of the product when highly soiled fluids are present.

5.4 Detailed operation of an MFC

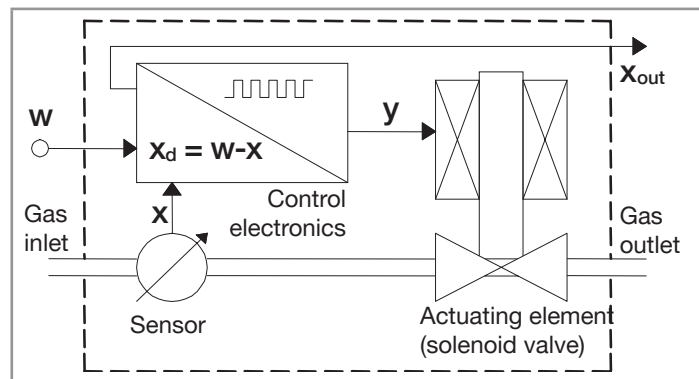

Fig. 2: Operating principle for the Mass Flow Controller

The control electronics compare the mass flow-rate (x) measured by the integrated flow sensor with the mass flow-rate set-point value (w) supplied to the MFC. The control electronics then calculate the actuating variable (y) to be supplied to the solenoid valve to control its opening. The flow-rate is either maintained at a constant value, or modified to a predefined profile.

The control operates independently of fluctuations in pressure or increases in the flow resistance which may be caused by soiling of the filter. The rapidly responding solenoid valve and the sensor dynamics define the overall responding time.

The measured value for the mass flow-rate is also transmitted (x_{out}) to a remote device via an analogue output or a digital output (field bus).

5.4.1 Control electronics

The control electronics:

- process the mass flow-rate set-point values and measured values,
- control the solenoid valve.

Set-point value

The set-point value (w) is transmitted either by an analogue, normalized input signal, or digitally via the serial interface or the field bus interface. If the set-point value is supplied by analogue transmission, the following assignments are applied:

Signal range	Set-point associated with the range min.	Set-point associated with the range max.
4...20 mA	4 mA, $w = 0 \%$	20 mA, $w = 100 \%$
0...20 mA	0 mA, $w = 0 \%$	20 mA, $w = 100 \%$
0...5 V	0 V, $w = 0 \%$	5 V, $w = 100 \%$
0...10 V	0 V, $w = 0 \%$	10 V, $w = 100 \%$

For the control of a system where quick flow-rate changes are not permitted, a ramp function can be activated. The settings for an ascending and a descending set-point value can be set separately.



More detailed information on the ramp function and on all other functions can be found in the software documentation for the MFM / MFC.

Control settings

The initial control settings are set at the factory.

- Amplification factors:

After start-up, the controller operates with amplification factors dependent on the loop properties. When the *Autotune* function runs, these are determined automatically. This function enables the control settings to be optimized for the system's actual conditions.

- Control dynamics setting:

The device has a setting which can change the control dynamics with the aid of the "Mass Flow Communicator" software (see chapter [10.1.3](#)). Its extreme effects are:

1. a very quick adjustment in which overshoots are possible. This enables the controller to respond immediately to very low control deviations, causing the control to be very turbulent,
2. a slower adjustment to the required flow-rate. If the system is less dynamic, the behavior of the controller may be damped so that minor fluctuations of the measured value or set-point value are adjusted slowly.

Zero point shut-off

A zero point shut-off is integrated to ensure the sealing function of the valve. This is activated if the following conditions occur at the same time:

Set-point value < 2 % of nominal flow-rate Q_{nom} (with control range 1:50)	and	Measured value < 2 % of nominal flow-rate Q_{nom} (with control range 1:50)
--	-----	---



If the zero point shut-off is active, the PWM signal is set to 0 % so that the valve is completely closed.

5.4.2 MFC solenoid valve

The solenoid valve used for an MFC is a direct-acting, normally closed solenoid control valve.

The ND (nominal diameter) of the solenoid control valve is determined by the required nominal flow-rate Q_{nom} , the pressure conditions in the process and the density of the operating fluid.



If the device is operated within the specified pressure range, the solenoid valve also takes over the sealing function together with the control function.

Limitation: in the case of special, hard seal materials, the seal function cannot be ensured. In this case an additional shut-off valve may be required.

6 TECHNICAL DATA

6.1 Standards and directives

The device complies with the relevant EU harmonisation legislation. In addition, the device also complies with the requirements of the laws of the United Kingdom.

The harmonised standards that have been applied for the conformity assessment procedure are listed in the current version of the EU Declaration of Conformity/UK Declaration of Conformity.

6.2 Certifications

UL-Certification

Some versions of the device are UL-certified. For the use of a UL-device, please refer to chapter [6.7 Electrical data](#).

6.3 Operating conditions



WARNING

Risk of injury from malfunction due to effects of weather!

The device is not designed for unrestricted use outdoors.

- ▶ Protect the device from direct sunlight.
- ▶ Observe the ambient temperature permitted for the device.
- ▶ Protect the device from humidity.

Setting	Value
Ambient temperature	-10...+50 °C ¹⁾
Fluid temperature	<ul style="list-style-type: none"> • -10...+70 °C • -10...+60 °C for oxygen
Air humidity	< 95 %, non-condensing
Protection rating acc. to EN 60529	Only if devices are cabled and the connectors are plugged in and tightened: IP40 ²⁾
Operating pressure	Max. 10 bar (depending on the nominal diameter of the proportional valve)

¹⁾ Up to 40 °C for type 8713 / 8715, with an integrated 5 W valve.

²⁾ IP40 has not been evaluated according to UL 61010 but determined by Bürkert.

6.4 Mechanical data

The device may be mounted in a horizontal or vertical position: see the calibration plate and/or the calibration protocol.

Type	Base block material	Material of the housing	Port connections
8700, 8710	Stainless steel 1.4305	Polycarbonate (PC) or sheet stainless steel 1.4301	G 1/4, NPT 1/4, flange
8701, 8711	Stainless steel 1.4305 or aluminium	Polycarbonate (PC) or sheet stainless steel 1.4301	G 1/4, NPT 1/4, flange
8703, 8713	Stainless steel 1.4305 or aluminium	Sheet stainless steel 1.4301	G 1/4, NPT 1/4, flange
8705, 8715	Stainless steel 1.4305	Sheet stainless steel 1.4301	G 1/4, NPT 1/4, flange

Sealing material: EPDM, FKM, FFKM, PCTFE (see name plate). Other parts in contact with fluids, proportional valve: 1.4310, 1.4113 and 1.4305.

6.5 Dimensions

→ Please refer to the technical data sheets regarding the device, available at: country.burkert.com

6.6 Fluidic data

6.6.1 Overview of measurement specifications

Typ	8700, 8710	8701, 8711	8703, 8713	8705, 8715
Full scale range, ref. to N ₂ (l _N /min)	0.01...15	0.01...80	0.01...80	0.01...15
Measuring accuracy (after heating time) ¹⁾	±1.5 % of the MV ±0.3 % of the FS	±0.8 % of the MV ±0.3 % of the FS	±0.8 % of the MV ±0.3 % of the FS	±1.5 % of the MV ±0.3 % of the FS
Span/control range	1:50	1:50 ²⁾	1:50 ²⁾	1:50
Settling time (MFC) or response time (MFM) in ms	< 3000	< 300	< 300	< 3000

¹⁾ MV = measured value / FS = full scale

²⁾ Higher span (e.g. 1:100) possible on request. Repeatability: ± 0.1 % of the full scale.

6.6.2 Quality of the operating medium

For the required measurement and control precision and to meet the safety requirements, the gas or gas mixture must meet the following quality criteria according to standard ISO 8573-1 (Compressed Air - Part 1: Contaminants and purity classes):

Maximum particle size:	Class 2:	1 µm
Maximum particle density	Class 2:	1 mg/m ³
Maximum dew point under pressure:	Class 4:	3 °C
Maximum oil concentration	Class 1:	0.01 mg/m ³

For further information see ISO 8573-1.

Other hazardous gases are possible on demand; under normal operating conditions the devices do not release any gas.

6.6.3 Pressure loss characteristics

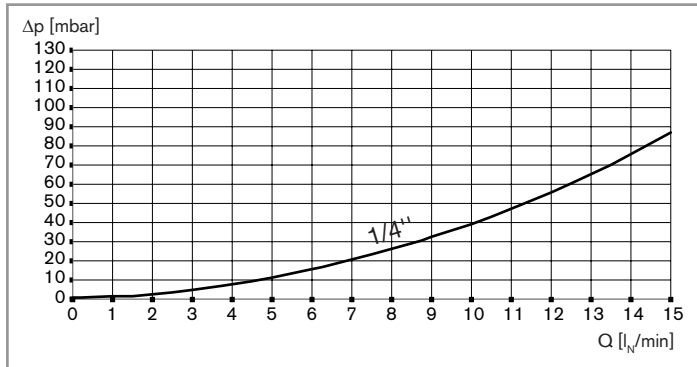

Fig. 3: Pressure loss diagram (reference air, with a 250 μm inlet mesh filter), types 8700 / 8705

The diagram shows exemplarily the pressure loss characteristics when air flowing through.

For determining the pressure loss with another gas first calculate the air equivalent of the other gas.

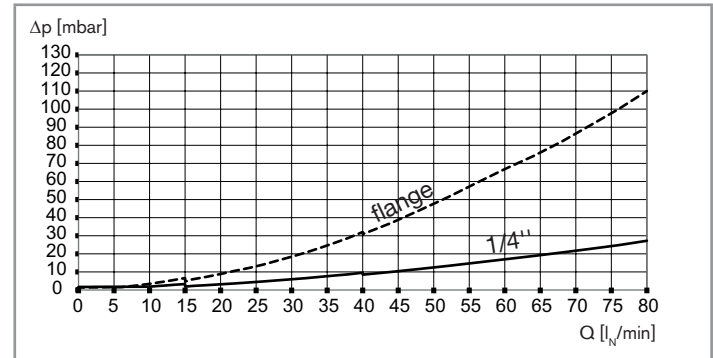

Fig. 4: Pressure loss diagram (reference air, with a 250 μm inlet mesh filter), types 8701 / 8703

The diagram shows exemplarily the pressure loss characteristics when air flowing through.

Further it differentiates two designs, first one with ¼ inch connectors and second one with connections on the bottom of the flowmeter (used for assembly on manifolds).

For determining the pressure loss with another gas first calculate the air equivalent of the other gas and respect the fluidics needed with the other gas.

6.7 Electrical data

6.7.1 Electrical data for types 8703 / 8705 / 8713 / 8715



WARNING!

For UL-certified components, only use limited power circuits of "NEC Class 2".

Specification	Type
Power supply	24 V DC ± 10 %; residual ripple < 2 %
Maximum Power required	<ul style="list-style-type: none"> • 8703 / 8705: 2.5 W • 8713 / 8715: 11.5 W
Binary input (configurable)	1, to be connected to DGND for activation
Communication interface	RS485 full or half duplex, supporting the MODBUS protocol
Relay output (configurable)	1, potential-free changer, 30 V, 1 A
LEDs (configurable)	3 LEDs, status display for POWER, COMM, ERROR
Electrical connections	Sub-D 9-pin male fixed connector

6.7.2 Electrical data for types 8700 / 8701 / 8710 / 8711



WARNING!

For UL-certified components, only use limited power circuits of "NEC Class 2".

Specification	Type
Power supply	24 V DC $\pm 10\%$; residual ripple $< 2\%$
Maximum Power required	<ul style="list-style-type: none"> • 8700 / 8701: 5 W • 8710 / 8711: 14 W
MFC 8710 and 8711 only: Analogue input (configurable)	<ul style="list-style-type: none"> • 0/4...20 mA, input impedance max.: 300 Ω, resolution : 5 μA • 0...5/10 V, input impedance min.: 20 kΩ, resolution: 2.5 mV
Binary inputs (configurable)	2, to be connected to DGND for activation
Analogue output (configurable)	<ul style="list-style-type: none"> • 0/4...20 mA, max. load: 600 Ω, resolution: 20 μA • 0...5/10 V, max. current: 10 mA, resolution : 10 mV
Communication interface (alternative to analogue input + output)	PROFIBUS DP V1 or CANopen
Relay output (configurable)	1, potential-free changer, 30 V, 1 A
LEDs (configurable)	3 LEDs, status display for POWER, COMM or LIMIT, ERROR
Electrical connections	Sub-D 15-pin male fixed connector
Additional connections for version with field bus	M12 5-pin male fixed connector (CANopen) or M12 5-pin female fixed connector (PROFIBUS)

6.8 Markings



CAUTION

Risk of injury from pressure and discharge of fluid.

Important device-specific technical data is indicated on the name plate and the calibration plate.

- ▶ Observe the permitted fluid according to the name plate (depending on seal material).
- ▶ Observe the permitted pressure range on the calibration plate of the device.

6.8.1 Standard name plate

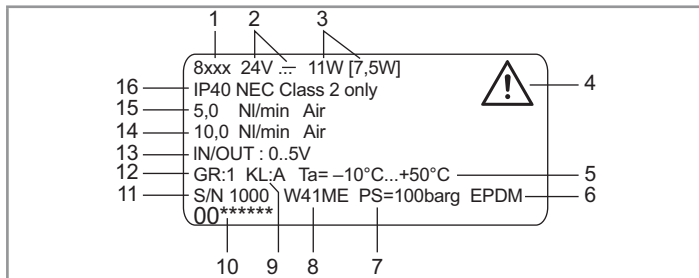

1. Type of the device
2. Supply voltage, direct current
3. Consumption according to UL 61010-1 [typical consumption ¹⁾]
4. Warning symbol: observe the Operating Instructions delivered with the device.
5. Ambient temperature
6. Sealing material
7. Burst pressure
8. Manufacturing code
9. Class of the valve (according to the DVGW ²⁾)
10. Device order code
11. Serial number
12. Category of the device
13. In / Out signal
14. Nominal flow rate (Q_{nom}), units and operating medium gas 2
15. Nominal flow rate (Q_{nom}), units and operating medium gas 1
16. Protection rating

¹⁾ Conditions: ambient temperature 23 °C, nominal flow rate 100 %, regulation for 30 minutes

²⁾ DVGW = Deutsches Verein des Gas- und Wasserfaches

Fig. 5: Description of the name plate (example)

6.8.2 Calibration plate

<p>1— Calibration data 00*****</p> <p>2— Medium 1 Medium 2</p> <p>3— P1 : 10,00 barg P1 : 10,00 barg</p> <p>4— Mounting: horizontal upright</p> <p>5— QC passed: ._.:._:._</p>	<ol style="list-style-type: none"> 1. Calibration fluid 2. Calibration pressure 3. Mounting position 4. Calibration date 5. Order code of the device
--	---

Fig. 6: Description of the calibration plate (example)

6.8.3 Additional marking

 <p>1—</p> <p>2—</p>	<ol style="list-style-type: none"> 1. Conformity marking 2. Certification
---	---

Fig. 7: Description of the additional marking (example)



Find the description of the older markings on the device in the supplement at country.burkert.com.

7 INSTALLATION AND COMMISSIONING

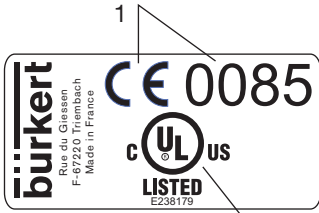
7.1 Safety instructions



DANGER

Danger due to high pressure in the installation/device.

- ▶ Before working on the installation or device, cut the pressure and vent and drain the pipes.

Risk of injury from electric shocks.

- ▶ Before working on the installation or device, switch off the power and ensure that it cannot be reactivated.
- ▶ Observe the applicable accident protection and safety regulations for electrical equipment!

Danger due to escape of the medium.

- ▶ Observe the applicable accident protection and safety regulations relating to the operating medium used.



WARNING

Danger due to nonconforming installation or commissioning.

- ▶ Installation and commissioning can only be carried out by qualified and skilled staff with the appropriate tools.

Risk of injury due to unintentional switch on of power supply or uncontrolled restarting of the installation.

- ▶ Take appropriate measures to avoid unintentional activation of the installation.
- ▶ Guarantee a set or controlled restarting of the process subsequent to any intervention on the device.

7.2 Prior to installation

- Before installing the MFM / MFC, remove dirt from the pipes and fluid system components.
- Connect a suitable filter ($\leq 25 \mu\text{m}$ mesh size) upstream to ensure that the operating fluid is kept clean.

NOTE

- Use a power supply unit with adequate power.
- Observe the maximum permitted residual ripple of the operating voltage.

7.3 Sequence of the steps to be performed

1. Mechanical installation
2. Fluid installation
3. Electrical installation
4. Set the device parameters
5. Pressurize the lines with operating fluid
6. Flush and completely deaerate the lines with operating fluid at the calibration pressure

7.4 Setting the parameters

7.4.1 Setting the bus address



To ensure trouble-free setting, reset the device by switching off the power supply to the device.

The bus address of the device can be set either via the Bürkert configuration tool "Mass Flow Communicator" in the "Views" window → PROFIBUS / CANopen or directly via the master bus.

The address must be reinitialized after a change on the slave and on the master. It may be necessary, depending on the bus, to send a corresponding telegram.

7.4.2 Setting the bus address on a device with rotary switches for setting the address (type 8700 / 8701 / 8710 / 8711)



To set an address via the master bus:

- Set the switches on an address outside the permitted range.
- Restart the device.
- Set the address via the Mass Flow Communicator.

When the device is switched on, the address set with the rotary switches is accepted as a slave address.

Valid addresses are:

- PROFIBUS 0...126
- CANopen 1...127

If the address was set outside the permitted range, the address setting has the validity as described in chapter [7.4.1](#)

LSB	Unit position	Digit times	
Unit position (x 1)	0...9	1	0...9
MSB	Decade position (x 10)	10	
	0...9	→	0...90
	A	→	100
	B	→	110
	C	→	120
	D	→	130
	E	→	140
	F	→	150

The address is composed of LSB + MSB

Example:

Address:	MSB setting	LSB setting
1	0	1
63	6	3
100	A	0
127	C	7

Fig. 8: Setting the bus address on devices with rotary switch (types 8700 / 8701 / 8710 / 8711)

7.4.3 Pin assignment

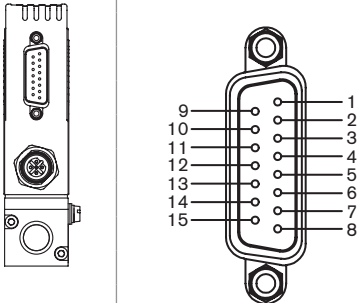
MFM types 8700, 8701: 15-pin Sub-D plug	Pin	Assignment MFM Typ 8700, 8701	Assignment MFC Typ 8710, 8711
	1	Relay - Normally closed contact	
	2	Relay - Normally open contact	
	3	Relay - Center contact	
	4	GND for 24 V - Supply and binary inputs	
	5	24 V - Supply +	
	6	8 V - Output (for internal use only)	
	7 ¹⁾	Not used	Set-point value input GND
	8 ¹⁾	Not used	Set-point value input +
	9 ²⁾	Measured value output GND	
	10 ²⁾	Measured value output +	
	11	DGND (for RS232)	
	12	Binary input 1	
	13	Binary input 2	
	14 ³⁾	RS232 R x D (without controller)	
	15 ³⁾	RS232 T x D (without controller)	

¹⁾ In the field bus version of MFC types 8710 / 8711 these connections are not used.

²⁾ In the field bus version of MFC types 8710 / 8711 and MFM types 8700 / 8701 these connections are not used.

³⁾ To use the RS232 interface, use an adapter (item no.: see chapter [10.1.1 Electrical accessories](#)).

Type 8710, 8711, 8713, 8715

Installation and commissioning

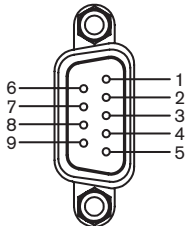
MFM types 8703, 8705 and MFC types 8713, 8715: 9-pin Sub-D plug	Pin	Assignment
	1	Binary input
	2	GND
	3	24 V - Supply +
	4	Relay - C Contact
	5	Relay - NC Contact
	6 ¹⁾	TX+ (RS485 - Y)
	7 ¹⁾	TX- (RS485 - Z)
	8 ¹⁾	RX- (RS485 - B)
	9 ¹⁾	RX+ (RS485 - A)

¹⁾ For operation in Half-Duplex mode, connect pin 6 to 9 and pin 7 to 8.

Pin assignment for field bus version

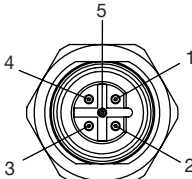
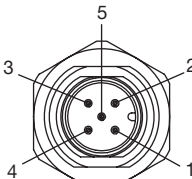
PROFIBUS DP socket, B encoded M12 (DP V1 max. 12 MBaud)	Pin	Assignment
	1	VDD ¹⁾
	2	RxD / TxD - N (line A)
	3	DGND
	4	RxD / TxD - N (line B)
	5	Not used
¹⁾ Only use this voltage to energize the PROFIBUS termination resistor.		
CANopen M12 connector	Pin	Assignment
	1	Shield
	2	Not used
	3	DGND
	4	CAN_H
	5	CAN_L

7.5 Mechanical installation

Observe the mounting position shown on the calibration plate or the calibration protocol.

7.6 Fluid installation



DANGER

Danger due to high pressure in the installation/device.

- ▶ Before working on the installation or device, cut the pressure and vent and drain the pipes.

Select the fluid connections suitable for the maximum flow-rate. There is no minimum upstream distance to be observed.

On request, the device may be supplied with the fluid connections fitted.



WARNING

Danger from leaks

If flow-rates are low and pressures high, ensure that the system is sealed to prevent incorrect metering or the operating fluid from leaking.

- ▶ To ensure that the seal is secure, observe the operations described below.

Install the fittings without subjecting them to any stresses. To seal the system properly, use fittings with olives.

Use a line with a suitable diameter and a smooth surface.

→ Cut the line squarely [1] and deburr [2].

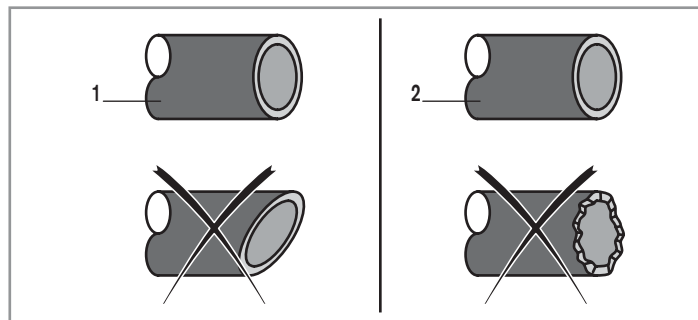

→ In order, fit the nut [A] and the olive onto the line.

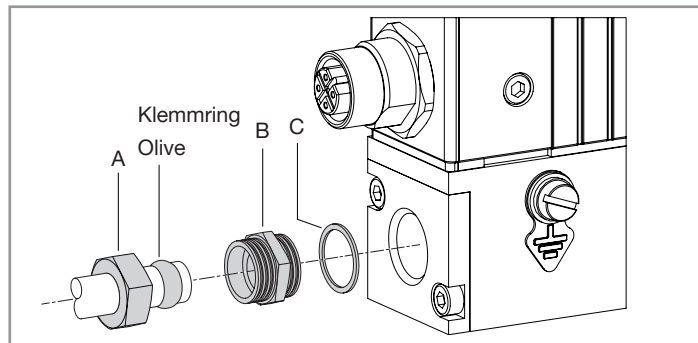

Type 8710, 8711, 8713, 8715

Installation and commissioning

→ Fit the washer [C] and screw the fitting [B] to the device.

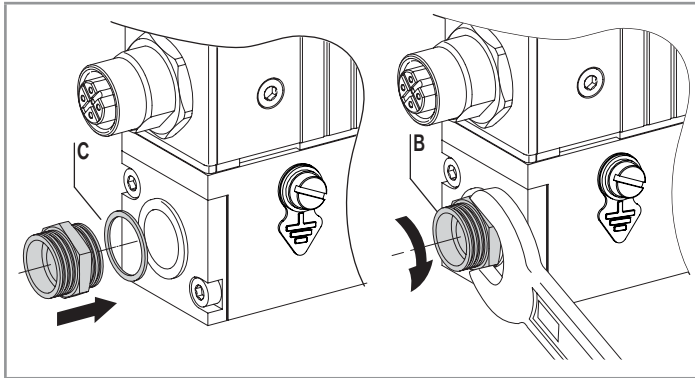

→ Insert the line and manually tighten the nut [A].

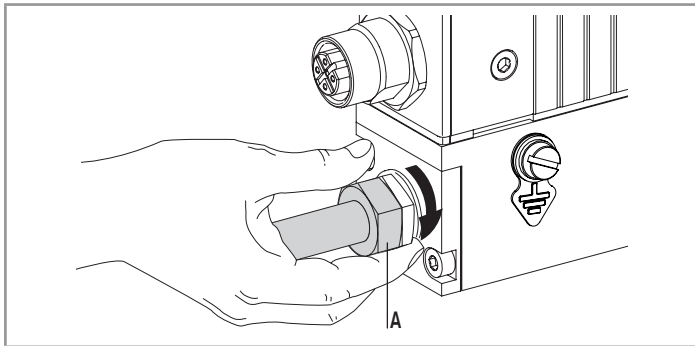

→ Finish tightening the nut with a suitable wrench to ensure the mounting is sealed.

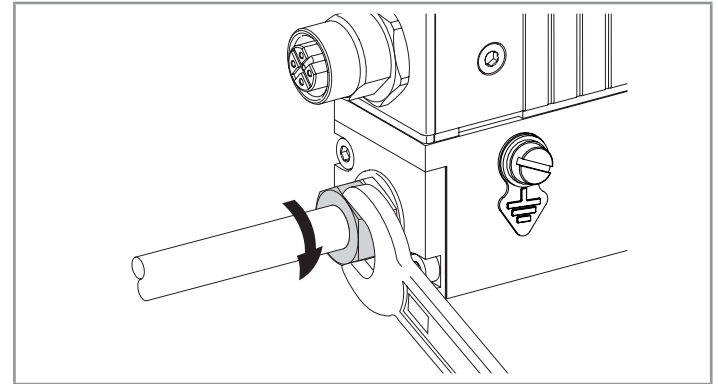

7.7 Electrical installation



DANGER

Risk of injury from electric shocks.

- ▶ Before working on the installation or device, switch off the power and ensure that it cannot be reactivated.
- ▶ Observe the applicable accident protection and safety regulations for electrical equipment!



WARNING

Risk of fire and ignition due to electrostatic discharge

If the device is electrostatically charged, highly flammable fluid vapors may ignite if electrostatic discharge occurs.

- ▶ To avoid electrostatic charges, connect the device to the functional earth (FE) using the shortest possible cable with the largest possible cross section.

Danger from electromagnetic fields

If the FE connection is not connected, electromagnetic compatibility is not assured.

- ▶ Connect the device to the functional earth (FE) via the shortest possible cable (largest possible cross section).

NOTE

Important information for problem-free functioning of the device

The GND or earth connections of the MFM / MFC must always be connected individually.

If all the GND connections are connected together and only a single common connection fed to the control, the analogue signals risk being subjected to fluctuations and interference.

- Connect the functional earth (FE) to the screw indicated, for example using an earth terminal. The connection cable must be as short as possible and its cross section must be as large as possible.

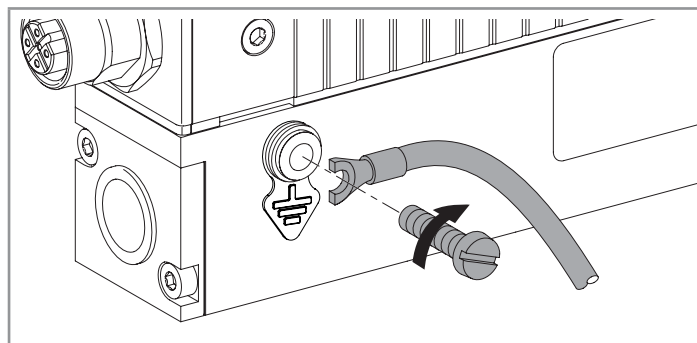

8 OPERATION AND FUNCTION

8.1 Safety instructions

WARNING

Risk of injury due to non-conforming operating.

Non-conforming operating could lead to injuries and damage the device and its surroundings.

- ▶ Operating personnel must familiarize themselves with the contents of the Operating Instructions.
- ▶ Observe the safety instructions and use the devices as indicated in these Operating Instructions.
- ▶ Only adequately trained personnel may operate the device.

8.2 Operation of the MFM / MFC

The MFM / MFC is operated by means of analogue standard signals or field bus communication as well as binary inputs. Three LEDs and a relay output are used for operation and status displays.

There is a serial interface via which a connection to a PC can be established, using the "Mass Flow Communicator" software.

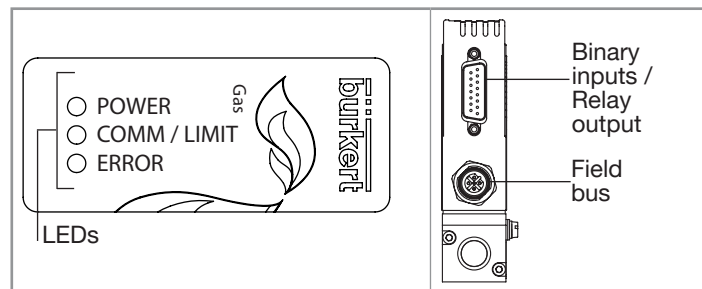



• Selecting the standard signals / Assigning the binary inputs

The standard signal type as well as the assignment of the binary inputs can be specified on order placement or configured via the "Mass Flow Communicator" PC software (see also chapter [10.1.3](#)).

• Assigning LEDs / Assigning the relay output

The assignment of the "COMM" or "LIMIT" LEDs as well as the assignment of the relay outputs can also be configured via the software (see also chapter [10.1.3](#)).

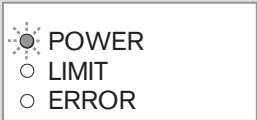
8.2.1 LED default assignment

LED status	Possible cause
POWER LED (green) on 	The device is energized.
POWER LED (green) flashing 	The <i>Autotune</i> function is in progress.
COMM LED (yellow) on 	The device is communicating via the field bus or the serial interface.

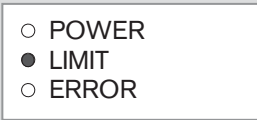
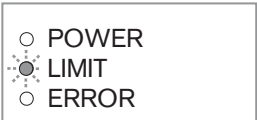
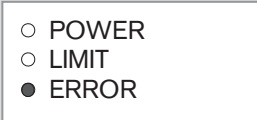
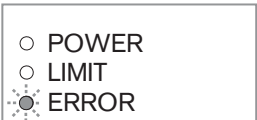
LED status	Possible cause
LIMIT LED (blue) on 	<ul style="list-style-type: none"> • MFM: indicates that the measured value has almost reached the nominal flow-rate. • MFC: indicates that the actuating variable of the proportional valve has almost reached 100 %. In practice this usually means that the pressure on the controller is not adequate to reach the required flow-rate.
LIMIT LED (blue) flashing 	The device is in an operating state other than the control mode or <i>Autotune</i> function.
ERROR LED (red) on 	Minor fault, for example the <i>Autotune</i> function has failed.
ERROR LED (red) flashing 	Major fault, sensor damaged, internal power supply voltage incorrect or operating pressure too high.

8.2.2 Inputs

Analogue input/output

The analogue input (MFC only) allows the set-point value, i.e. the required flow-rate value in the line, to be received.

The analogue output enables the measured flow-rate value to be supplied to the device to which it is connected.

Bus connection (field bus version only)

The set-point value received and the measured value are sent digitally via the field bus. It is possible to choose between PROFIBUS DP and CANopen (see also the additional Operating Instructions for field bus devices).

Binary inputs

If the binary inputs are activated, different operations can be run on the MFC and the latter can be switched to a specific operating mode. This is achieved by connecting the binary input to DGND for at least 0.5 s.

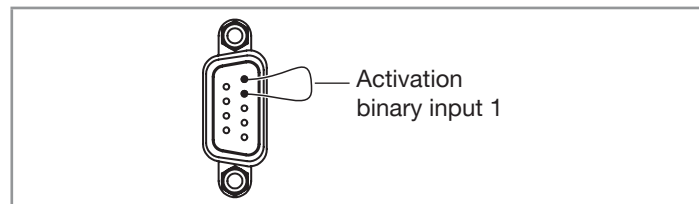

Fig. 9: Types 8703, 8705, 8713 and 8715

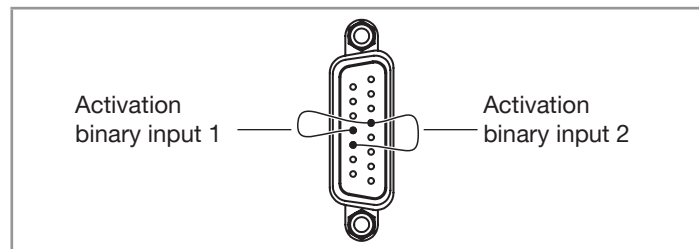

Fig. 10: Types 8700, 8701, 8710 and 8711

Input	Default assignment
Binary input 1	Autotune actuation
Binary input 2	Not used

Tab. 1: Default assignment of binary inputs.

Function	Description
Actuate <i>Autotune</i>	Start of <i>Autotune</i> function for optimization of the control settings to the conditions available in the system (see chapter 8.3).
Switch to specification 2	The calibration curve saved under Gas 2 as well as all settings entered there are used.
Totalizer Reset	The integrated totalizer (quantity integrator) is reset.
Start set-point value profile	Start of the saved set-point value profile (see chapter 8.3).
Control mode	Enables the solenoid valve to be opened at a given value (see chapter 8.3).
Correct safety value (*)	The safety value stored in the device is used as a flow-rate set-point value. In this case, the flow-rate set-point value received by the analogue input or field bus is ignored.
Close valve completely (*)	Valve completely closed. In this case, the flow-rate set-point value is ignored.
Open valve completely (*)	Valve completely opened. In this case, the flow-rate set-point value is ignored.

Tab. 2: Possible binary input functions.

(*) For these functions, you can choose the operation of the binary input (function activated by either opening or closing the connection to GND).

8.2.3 Relay outputs

The MFM / MFC have a relay output to indicate the operating state, limit values outside the maximum / minimum or a fault.

Output	Assignment
Relay output	y2 Limit

Tab. 3: Relay output default assignment

Function	Description
Not used	No function is assigned to the relay output
Power ON	The device is energized.
<i>Autotune</i> activated	The <i>Autotune</i> function is in progress.
Gas 1 or 2 active	Calibration curve 1 or 2 is used.
User-defined calibration active	The device operates at the calibration adjusted by customer.
Binary input 1 or 2 active	Binary input 1 or 2 has been activated.
Activate relay output by field bus	The status of the relay outputs is specified via the field bus or the serial interface.
Correct safety value active	The safety value is used as the set-point value.
Set-point value profile active	The set-point value profile stored in the device is used as the set-point value.
Control mode active	The control mode is active, i.e. the solenoid valve is opened at a given value.

Function	Description
Close valve completely active	The close valve completely function is activated.
Open valve completely active	The open valve completely function is activated.
Defective power requirement	The power requirement of the device is monitored. If this value is outside defined limits, this function is actuated. An excessively high or low power requirement may indicate a defective device.
Defective internal power supply	The operating voltage of the device is monitored. If the defined limits exceed the maximum or drop below the minimum, this function is actuated.
Defective power supply to the sensor	The power supply voltage to the sensor is monitored. If the defined limits exceed the maximum or drop below the minimum, this function is actuated.
Defective data storage	If data storage is in the non-volatile memory of the device, a fault has occurred.
Sensor fault	The device is able to detect a defective sensor via a self-test. If this is the case, this function is activated.
MFI fault	The field bus module (MFI) is defective or incorrectly equipped. Field bus communication is not possible.

Function	Description
x Limit	The measured value has exceeded or dropped below a limit value which can be configured.
w Limit	The set-point value has exceeded or dropped below a limit value which can be configured.
y2 Limit	The actuating variable has exceeded or dropped below a limit value which can be configured.
Totalisator Limit	The totalizer has exceeded or dropped below a limit value which can be configured.

Tab. 4: Possible relay output functions

8.3 MFC operating modes

The MFC can adopt different operating modes:

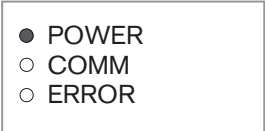
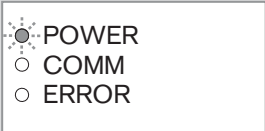
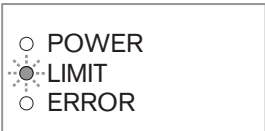
Operating mode	Status of the LEDs (default setting)	Binary input activation mode	This operating mode may be interrupted or ended by
Standard control mode (see chapter 8.3.1)	POWER LED (green) on 		<ul style="list-style-type: none"> • <i>Autotune</i> function • Safety function • Set-point value profile • Control mode
Function <i>Autotune</i> (see chapter 8.3.2)	POWER LED (green) flashing 	Input active for at least 0.5 s (permanent input activation leads to a function restart)	<ul style="list-style-type: none"> • Safety function • Device reset
Safety function (see chapter 8.3.3)	LIMIT LED (blue) flashing 	As long as the input is active	-

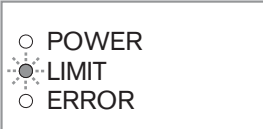
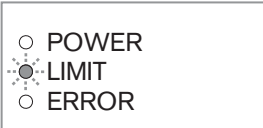
Operating mode	Status of the LEDs (default setting)	Binary input activation mode	This operating mode may be interrupted or ended by
Set-point value profile (see chapter 8.3.4)	LIMIT LED (blue) flashing 	Input active for at least 0.5 s (permanent input activation leads to a function restart)	<ul style="list-style-type: none"> • Function <i>Autotune</i> • Safety function • Device reset
Control mode (see chapter 8.3.5)	LIMIT LED (blue) flashing 	As long as the input is active	<ul style="list-style-type: none"> • Function <i>Autotune</i> • Safety function • Device reset

Tab. 5: Overview of the operating modes.

8.3.1 Standard control mode

In this operating mode, the flow-rate is corrected to the specified set-point value at a high dynamic.

The MFC is in this operating mode once energized, after a brief initialization phase. The green power light is on.

The set-point value is specified via the analogue input or the field bus, depending on the device version.

The controller settings are set in such a way that set-point value changes or actuating variables are corrected as quickly as possible without appreciable overshoot occurring.

The measured flow-rate value is available on the analogue output or the field bus, depending on the device version.



For the MFC:

If the LIMIT LED (blue) is on, this means that the control signal of the proportional solenoid valve is approaching the 100 % limit (see chapter 9.3).

The cause may be:

- either an insufficient pressure difference around the MFC, for example an insufficient inlet pressure,
- or a dirty inlet filter.

This means that the set point cannot be achieved and a difference between the set point and the measured value ($w - x$) persists.



For the MFM:

If the LIMIT LED (blue) is on, the measured mass flow is approaching the nominal flow-rate or has even exceeded it (see chapter 9.3).

If a high exceeding of the nominal flow rate occurs, a difference between the measured and the real flow rates may appear.

To permit an external reaction to this gap, a binary output is activated.

8.3.2 *Autotune* function



The *Autotune* function is run through during the final inspection in the factory, at the operating pressure and with the calibration fluid indicated in the calibration protocol.

Therefore, the re-actuation of this function is not essential.

However, the *Autotune* function should be activated if:

- the pressure conditions in the system have changed significantly,
- the calibration fluid does not correspond with the operating fluid.

In this operating mode, the device calculates and optimizes the control settings to the conditions present in the system.

The proportional solenoid valve is activated according to a predefined profile resulting in flow-rate changes. Thereby several control settings are adjusted to the conditions on-site. These settings are stored in the non-volatile memory of the device at the end of a successfully run *Autotune* function.

This function of the MFC is obtained by activating a binary input (configured on this function) for at least 0.5 s. The POWER LED (green) flashes to signal that the function is in progress.



WARNING

Various flow-rate changes occur when the *Autotune* is run.

- ▶ Do not switch off the power supply to the MFC.
- ▶ Keep the supply pressure constant.

→ Before activating the *Autotune* function, bring the medium pressure to a pressure close to the calibration pressure.

While the *Autotune* function is running, the MFC is not controlling.

When the *Autotune* function ends, the MFC returns to the operating mode it was in prior to activation.

8.3.3 Safety function

In this operating mode, the device behaves as in control mode, except that the set-point value is ignored and replaced by a predefined safety set-point value. The default safety set-point value is 0 %. This can be modified with the "Mass Flow Communicator" PC software.

This function of the MFC is obtained by activating a binary input or via the field bus, depending on the configuration of the device. The Limit LED (blue) flashes to signal that the function is in progress.

8.3.4 Set-point value profile

In this operating mode, the device behaves as in standard control mode, except that the external set-point value is ignored and replaced by a predefined chronology of up to 30 flow-rate values (configurable with the "Mass Flow Communicator" PC software).

This function of the MFC is obtained by activating a binary input (configured on this function) for at least 0.5 s. The LIMIT LED (blue) flashes to signal that the function is in progress.

If the set-point value profile has been activated by binary input and the input has been reset, once the set-point value profile has been executed, the device returns to the operating mode it was in prior to activation.

8.3.5 Control mode

In this operating mode, the set-point value enables a duty cycle to be directly supplied to the proportional valve.

Example: set-point value 10 % → duty cycle of the valve = 10 %.

This function of the MFC is obtained by activating a binary input or via the field bus, depending on the configuration of the device (configurable with the "Mass Flow Communicator" PC software).

The LIMIT LED (blue) flashes to signal that the function is in progress.

9 MAINTENANCE, TROUBLESHOOTING

9.1 Safety instructions



DANGER

Danger due to high pressure in the installation/device.

- ▶ Before working on the installation or device, cut the pressure and vent and drain the pipes.

Risk of injury from electric shocks.

- ▶ Before working on the installation or device, switch off the power and ensure that it cannot be reactivated.
- ▶ Observe the applicable accident protection and safety regulations for electrical equipment!



WARNING

Risk of injury due to non-conforming maintenance.

- ▶ This work may only be carried out by qualified, authorized technicians trained for working in environments where there is a risk of explosion and using the appropriate tools.
- ▶ Ensure that the restart of the installation is controlled after any interventions.

9.2 Maintenance

The MFM / MFC does not require any maintenance if used as indicated in these Operating Instructions. Routine recalibration is not required.



CAUTION

Risk of injury from operating faults and device failure if the device is opened.

Inside the device are elements to condition the flow and measure the flow-rate. It is permitted to enter the device, for example for cleaning, only as described in chapter [9.2.1](#).

Extensive device intervention causes a change to the sensor signal, requiring recalibration at the factory.

- ▶ Do not open the device.
- ▶ Cleaning other than that described in chapter [9.2.1](#) and calibration may only be performed by the manufacturer.

9.2.1 Maintenance if used with highly soiled fluids

If highly soiled fluids are used:

- Regularly check that the stainless steel mesh filter disc [5] is not soiled.
- Clean or replace it if necessary.

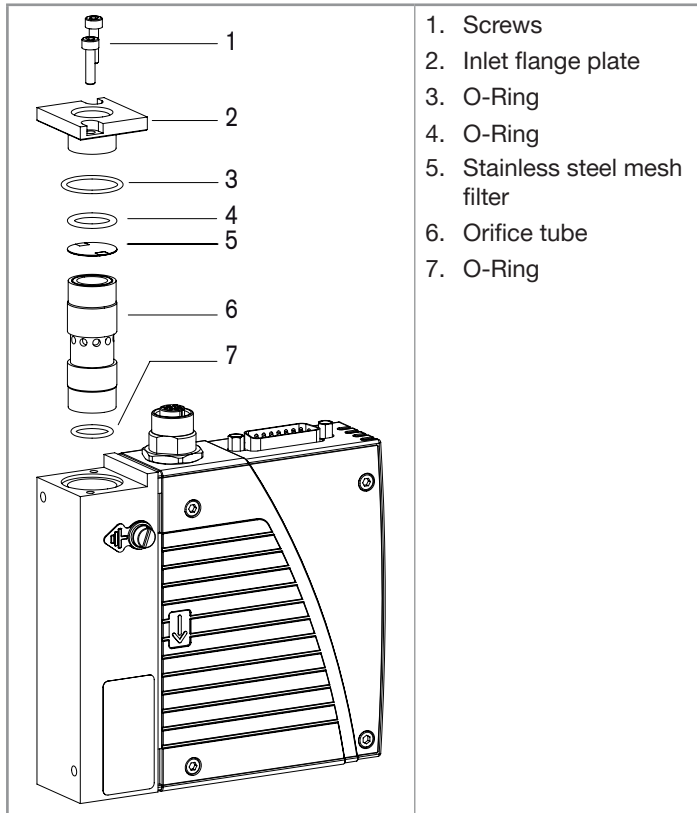

1. Screws
2. Inlet flange plate
3. O-Ring
4. O-Ring
5. Stainless steel mesh filter
6. Orifice tube
7. O-Ring

Procedure (spare parts, see chapter 10.2):

- To gain access to the stainless steel mesh filter disc [5], detach the input flange plate [2] (see Fig. 11).
- Take out the stainless steel mesh filter disc [5].
- Clean the stainless steel mesh filter disc [5] using distilled water (not tap water), acetone, isopropanol or compressed air.
- Dry the parts after cleaning.
- Re-insert parts in the correct sequence and position (see Fig. 11). The fine mesh of the filter disc [5] must face the input flange plate [2].

9.2.2 Cleaning and recalibration at the factory

If the sensor is excessively soiled or damaged by the operating gas, the device may deviate significantly from the mass flow-rate measurement. Cleaning or replacement followed by recalibration at the factory will then be required.

NOTE

Recalibration must be carried out at the factory as it requires the use of very precise references and a specific digital communication system.

Fig. 11: Maintenance, Cleaning

9.3 If you encounter problems

Problem	Possible cause	Recommended action
The POWER LED is off	No power supply.	→ Check the electrical connections.
The POWER LED flashes	The <i>Autotune</i> function is in progress.	→ See chapter 8.3 .
 POWER <input type="radio"/> COMM <input type="radio"/> ERROR		
The POWER LED goes out periodically	The Power supply cuts out periodically; the device implements a reset.	→ Use a power supply with adequate power.
	The voltage drop in the connection cable is too high.	→ Increase the cable cross section. → Reduce the cable length.
The LIMIT LED comes on	MFC: the solenoid valve adjustment has almost reached 100 %. The set-point value has not been obtained.	→ Increase the operating pressure (observe the maximum permitted supply pressure). → Check the cable resistance and reduce if required.
		→ Check the system dimensions. → Check the filters installed in the line and clean if required.
<input type="radio"/> POWER <input checked="" type="radio"/> LIMIT <input type="radio"/> ERROR	MFM: the measured flow-rate has almost reached or exceeded the nominal flow-rate.	→ Reduce the flow-rate.

Problem	Possible cause	Recommended action
<p>The LIMIT LED is flashing</p> <div style="border: 1px solid black; padding: 5px; width: fit-content;"> <input type="radio"/> POWER <input checked="" type="radio"/> LIMIT <input type="radio"/> ERROR </div>	<p>The device is in an operating state other than standard control mode or the <i>Autotune</i> function.</p>	<p>→ See chapter 8.3.</p>
<p>The ERROR LED is on</p> <div style="border: 1px solid black; padding: 5px; width: fit-content;"> <input type="radio"/> POWER <input type="radio"/> LIMIT <input checked="" type="radio"/> ERROR </div>	<p>Minor fault, for example the last <i>Autotune</i> function has failed.</p>	<p>→ Repeat <i>Autotune</i> function or reset the device to acknowledge the fault.</p>
<p>The ERROR LED flashes</p> <div style="border: 1px solid black; padding: 5px; width: fit-content;"> <input type="radio"/> POWER <input type="radio"/> LIMIT <input checked="" type="radio"/> ERROR </div>	<p>The residual ripple of the supply voltage is too high.</p>	<p>→ Use a power supply with a smooth output voltage at the required power.</p>
	<p>A serious fault has occurred, e.g.: defective sensor or fault in the internal power supply.</p>	<p>→ Return the device to the manufacturer to have the fault repaired.</p>
	<p>The sensor was operated above the permitted maximum operating pressure.</p>	<p>→ Reduce the operating pressure. → Return the device to the manufacturer to have the fault repaired.</p>
<p>No flow-rate available</p>	<p>The set-point value is below the limit for the zero point shut-off.</p>	<p>→ Increase the set-point value to > 2 % of the nominal flow-rate.</p>
	<p>The device is in an operating state other than standard control mode.</p>	<p>→ Check the operating state; see also chapter 8.3.</p>
	<p>The lines have been sized too large or may not yet have been completely deaerated.</p>	<p>→ Deaerate the lines. → Change the line diameter.</p>

Problem	Possible cause	Recommended action
The measured value fluctuates	The earth connection (FE = Functionnal Earth) is not correct.	→ Connect the FE to the earthing point (cable as short as possible, wire at least 2.5 mm ²).
	The controller must continuously correct fluctuations in an unstable pressure supply, e.g. by pumping.	→ Connect a suitable pressure controller upstream. → Install a buffer tank to absorb pressure fluctuations.
	The residual ripple of the supply voltage is too high.	→ Use a power supply with a smooth output voltage at the required power.
Set-point value at 0 %, but the fluid is circulating	The operating pressure is above the operating pressure maintained by the proportional valve.	→ Reduce the operating pressure. → Return the device to the manufacturer to have the fault repaired.
Set-point value = 0 %, valve is closed, no flow-rate in the line; but the measured flow-rate is not zero	The mounting position of the device is incorrect.	→ Install the MFC in the mounting position shown in the calibration protocol or the calibration plate and run an <i>Autotune</i> function to adjust to the operating conditions.
	A fluid other than the one marked on the calibration plate is used.	→ Return the device to the manufacturer for recalibration with the operating fluid.
Set-point value is not reached	The filter is blocked.	→ Clean or replace the filter.
	The primary pressure is too low.	→ Increase primary pressure to calibration pressure.
	The back pressure is too high.	→ Check components for soiling downstream of the device and if required clean.

10 ACCESSORIES / SPARE PARTS



CAUTION

Risk of injury and/or damage caused by the use of unsuitable parts.

Incorrect accessories and unsuitable replacement parts may cause injuries and damage the device and the surrounding area.

► Use only original accessories from Bürkert.

10.1 Accessories

The Bürkert accessories indicated below are recommended for problem-free operation, maintenance and repair of the device.

10.1.1 Electrical accessories

Types	Item	Order code
8700, 8701, 8710, 8711	SUB-D 15-pin plug to be soldered)	918 274
	Cover for SUB-D 15-pin plug	918 408
	Sub-D 15-pin plug with 5 m cable, with stripped end	787 737
	Sub-D 15-pin plug with 10 m cable, with stripped end	787 738
	RS232 adapter for connection to a PC	654 748
	Extension cable for Sub-D 9-pin plug, RS232, 2 m	917 039
	RS422 adapter	666 371
	USB adapter	670 639
	Configuration software (Mass Flow Communicator)	Can be downloaded at country.burkert.com
	PROFIBUS versions of types 8700, 8701, 8710 and 8711	Straight M12 plug (code B)
Straight M12 socket (coupling) (code B)		918 447
PROFIBUS (*) Y-piece		902 098
PROFIBUS terminal resistor (code B)		902 553

Types	Item	Order code
PROFIBUS versions of types 8700, 8701, 8710 and 8711	GSD sheet	Can be downloaded at country.burkert.com
CANopen version of types 8700, 8701, 8710 and 8711	Straight M12 plug (code A)	917 115
	Straight M12 socket (coupling) (code A)	917 116
	DVN/CAN (*) Y-piece	788 643
	DVN/CAN terminal resistor (code A)	On request
8703, 8705, 8713, 8715	SUB-D 9-pin base (to be soldered)	917 623
	RS232 adapter for connection to a PC	667 530
	Extension cable for Sub-D 9-pin plug, RS232, 2 m	917 039
	USB adapter	670 693
	Sub-D 9-pin adapter with 2 terminal blocks (for 2 connection cables)	919 465

(*) The two previous M12 connectors cannot be used together on the same side of the Y-junction. At least one of the two M12 connectors must be a prefabricated cable with a thinner connector.

10.1.2 Fluid accessories

The MFM / MFC are equipped with a connection plate which uses a DIN ISO 228/1 thread process connection.

A threaded fitting available as an accessory is used to connect the device to a line:

- the connection to the device side has a DIN ISO 228/1 thread,
- the connection to the line side is available in a range of dimensions.



A sealing ring must be ordered for each screw fitting!

Connection to the device, with DIN ISO 228/1 thread	Diameter of the line	Material	Order code	Order code, sealing ring
G 1/4	6 mm	Stainless steel	901 538	901 575
G 1/4	8 mm		901 540	901 575
G 1/4	1/4"		901 551	901 579
G 1/4	3/8"		901 553	901 579



Other accessories for the fluid connection of an MFM / MFC can be found under Type 1013 in the Bürkert accessories catalog.

10.1.3 Mass Flow Communicator (PC software)

The "Mass Flow Communicator" PC software designed for communication with the devices from the Mass Flow Controller and Liquid Flow Controller families supplied by Bürkert.



The software runs on the Windows platform and communicates with the MFM / MFC via a serial interface.

This software enables:

- information specific to the device to be read,
- the assignment of binary inputs and outputs to be changed,
- the assignment of LEDs to be changed,
- various functions to be activated,
- certain dynamic properties to be modified,
- a user specific calibration to be performed,
- the firmware to be updated,
- ...

10.1.4 Additional documentation

Item	Order code
Supplement to the Operating Instructions for field bus devices	804 553
Contamination Declaration	806 075
"Configuration via PROFIBUS with GDS file" addendum	805 923

10.2 Spare part

Item	Order code
Stainless steel mesh filter, mesh size 250 µm, for 8700, 8701, 8703	654 733
Stainless steel mesh filter, mesh size 25 µm, for 8710, 8711, 8713	676 329

11 SHUTDOWN

11.1 Safety instructions



DANGER

Danger due to high pressure in the installation/device.

- ▶ Before working on the installation or device, cut the pressure and vent and drain the pipes.

Risk of injury from electric shocks.

- ▶ Before working on the installation or device, switch off the power and ensure that it cannot be reactivated.
- ▶ Observe the applicable accident protection and safety regulations for electrical equipment!

Danger due to escape of the medium.

- ▶ Observe the applicable accident protection and safety regulations relating to the operating medium used.



WARNING

Risk of injury from nonconforming dismantling.

- ▶ Maintenance must only be carried out by qualified and skilled staff with the appropriate tools.

11.2 Dismounting of the MFM / MFC

Procedure:

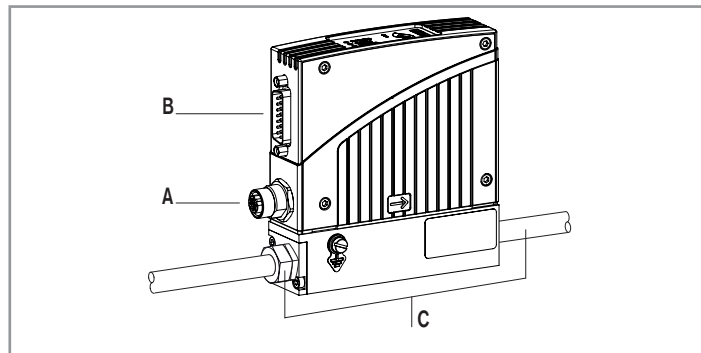

- Relieve the operating medium pressure in the system.
- Clean the device using a neutral fluid (nitrogen, for example).
- Relieve the rinsing medium pressure in the system.
- Switch off the power supply [A].
- Disconnect the electrical connections [B].
- Disconnect the fluid connections [C].
- Remove the MFM / MFC.

12 PACKAGING, STORAGE, TRANSPORT

12.1 Packaging, Transport

NOTE

Damage due to transport

Inadequately protected equipment may be damaged during transport.

- ▶ Remove all cables, connections, separate filters and installation material.
- ▶ Clean and air contaminated devices.
- ▶ Protect fluid connections from damage by fitting protective caps and seal.
- ▶ Pack the device in two suitable bags, sealed with protective film.
- ▶ During transportation protect the device against humidity and dirt in shock-resistant packaging.
- ▶ Do not expose the device to temperatures outside the storage temperature range.

12.2 Storage

NOTE

Poor storage can damage the device.

- ▶ Store the device in a dry place away from dust.
- ▶ Storage temperature: $-10\text{ °C} \dots +70\text{ °C}$.

13 RETURNING THE DEVICE



No work or tests will be carried out on the device until there is a valid Contamination Declaration.

The Contamination Declaration can be downloaded from our Homepage or requested from your local after-sales service.

country.burkert.com

To return a device already in use, a returns number is required.

If you would like to return a device already in use to Bürkert, proceed as follows:

- Complete the Contamination Declaration.
- Send the declaration to the address indicated on the form: Bürkert will fax or e-mail you a returns number.
- Pack the device in consideration of the information in chapter [12.1](#).
- Return the device to Bürkert with the Contamination Declaration, quoting this returns number.

Address:

Bürkert Fluid Control Systems
Corporate Quality / Complaint Management
Chr.-Bürkert-Str. 13–17
D-74653 Ingelfingen
Tel. + 49 (0) 7940 - 10 91 599
Fax + 49 (0) 7940 - 10 91 490
E-mail: service.international@burkert.com

14 DISPOSAL OF THE DEVICE

Environmentally friendly disposal



- ▶ Follow national regulations regarding disposal and the environment.
- ▶ Collect electrical and electronic devices separately and dispose of them as special waste.

Further information: country.burkert.com.

www.burkert.com