

PROPORTION **AIR**

PRESSURE FLOW FORCE TENSION POSITION TORQUE VACUUM

ELECTRO-PNEUMATIC PRESSURE REGULATORS

QBT

PRESSURE Vacuum to 175 psig

FLOW Up to 1.2 scfm

ACCURACY +/- 0.2% full scale

Up to 12 bar & 34 Lit/Min

QBS

PRESSURE Vacuum to 500 psig

FLOW Up to 1.2 scfm

ACCURACY +/- 0.25% full scale

Up to 34 bar & 34 Lit/Min

QBX

PRESSURE Vacuum to 175 psig

FLOW Up to 1.2 scfm

ACCURACY +/- 0.2% full scale

Up to 12 bar & 34 Lit/Min

Accurate & Repeatable

High Pressure Control

On-Board Ethernet Option

FUNCTIONAL DESCRIPTION of the QB-Series

The QB Series uses Proportion-Air's patented technology for closed loop control. The QB Series valves can be built in either a single loop or double loop control scheme.

The QBT Series is used to control pressure of inert gases from full vacuum up to 175 psig (12 bar).

The QBS is used in applications where the maximum calibrated pressure ranges are between 175 and 500 psig (34 bar). The QBS Series can also be used in applications where the pressure ranges are below 175 psig (12 bar) if the wetted parts on the QBS are compatible with the media being controlled. The QBS Series uses a solid one piece manifold for added strength, available in anodized aluminum or stainless steel. There are two outlet ports which allows flexibility in mounting options. In all QBS models, a stainless steel pressure sensor that utilizes dry technology instead of liquid fill, is used internally for increased reliability and enhanced media compatibility.

THEORY OF OPERATION

The QB1 is a single loop model consisting of valves, manifold, internal pressure transducer, and electronic controls. Output pressure is proportional to an electrical signal input. Pressure is controlled by two solenoid valves. One valve functions as the inlet control, the other as exhaust. The pressure output is measured by a pressure transducer internal to the QB1 and provides a feedback signal to the electronic controls. This feedback signal is compared against the command signal input. A difference between the two signals causes one of the solenoid valves to open allowing flow in or out of the system. Accurate pressure is maintained by controlling these two valves.

The QB2 is similar to the QB1 but uses a double loop control scheme. In addition to the internal pressure transducer, the QB2 also receives a feedback signal from an external sensing device. The external signal functions as the primary feedback signal which is compared against the command signal input. This outer loop comparison is then used to provide a command to the inner loop. A difference between the two comparisons causes one of the solenoid valves to open allowing flow in or out of the system.

Since the external feedback signal is electrical, control is not limited to pressure. Using other types of sensors allows control over parameters such as force, position, flow, etc. Usually in these applications the QB2 valve functions as pilot to a slave regulator controlling the end result. With a sensor providing system feedback, the package becomes a closed loop control system.

The QB control valve is specified as a stand alone valve in static applications with low flow requirements. It can also be used as a pilot to air piloted regulators (volume boosters) in applications where the flow rate of the controlled pressure is higher than QB's flow rate.

COMMAND SIGNAL

Command inputs come in a choice of either 0 to 10 Vdc, 4 to 20mA, Modbus or Ethernet (QBX only).

MONITOR SIGNAL

All QB's come with a 0-10 volt or an optional 4-20mA monitor signal for output to a panel meter or controller for data acquisition or quality assurance needs. On a QB1, the monitor signal represents the internal pressure transducer that is measuring the work pressure. On a QB2, the monitor signal represents the signal from the external sensor that is monitoring the output downstream.

PERFORMANCE CHARACTERISTICS

LINEARITY

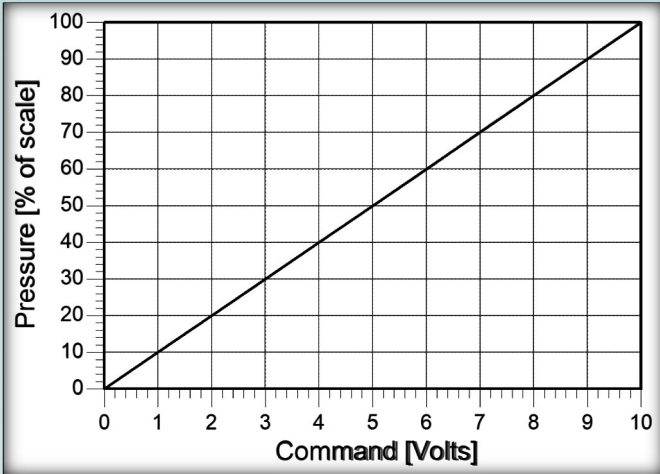

This chart shows the linear characteristics of QB products when given a ramp signal from 0 to 10 volts. Characteristics would be similar for 4 to 20 mA units.

RESPONSE TO STEP INPUT

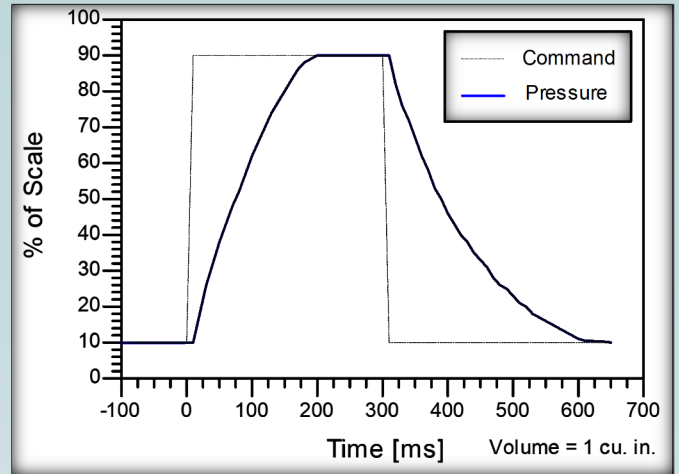

Times for QB to fill/exhaust a closed chamber. Step command signal is superimposed over pressure trace. Time is determined by the difference between command signal and pressure achieved.

FLOW CHARACTERISTICS

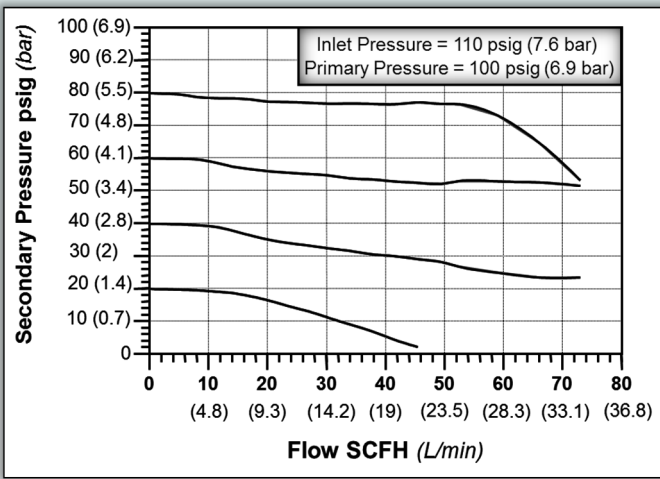

Regulating characteristics of a QB from no flow condition to full flow. To use, choose pressure setting from left end of chart at no flow conditions. Follow curve out until drop begins to occur. Read flow from bottom.

GENERAL INLET PRESSURE RATING

For valve that is ordered with maximum calibrated pressure of:	Maximum inlet pressure is:
Vacuum up to 10 psig (0.7 bar)	Consult factory
11 to 20 psig (0.8 to 1.4 bar)	35 psig (2.4 bar)
21 to 44 psig (1.5 to 3 bar)	55 psig (3.8 bar)
45 to 100 psig (3.1 to 6.9 bar)	110 psig (7.6 bar)
101 to 200 psig (7 to 13.8 bar)	220 psig (15.2 bar)
201 to 300 psig (13.9 to 20.7 bar)	330 psig (22.8 bar)
301 to 500 psig (20.8 to 34 bar)	550 psig (37.9 bar)

As of August 2014 Production of the BB -Series pressure regulator is discontinued. The QBX is the replacement for all BB models. Please contact the factory for assistance in crossing over your old BB units.



REPLACE WITH QBX



Pages 8 to 11



QBT

Proven Industries and Applications

Applicable to all QB Series Regulators

Bread & Bakery Product Manufacturing* (NAICS 31181)

Proof box temperature control using saturated steam
 Humidity control in proof box using saturated steam
 Bagger "force up" force control
 Air knife to blow moisture from dough

Pharmaceutical & Medicine Manufacturing* (NAICS 3254)

Position Control - Dosing of batch using syringe
 Calibrate force of insulin pump motor with load cell feedback
 Atomizing pill coating

*Many applications require more flow than QB-series allows. We will pilot a mechanical regulator without sacrificing accuracy & repeatability for higher flow applications. Call us to discuss your opportunity.

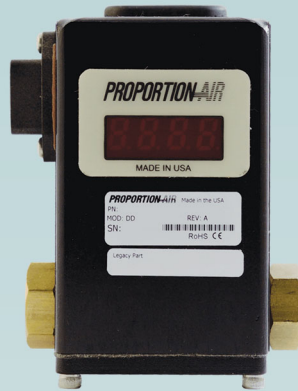

ELECTRICAL

Supply Voltage	15 to 24 VDC
Supply Current	100 to 250 mA DC
Command VDC	0 to 10 VDC
Command Current	4 to 20 mA DC
Monitor VDC	0 to 10 VDC
Monitor Current	4 to 20 mA DC
Command Signal Impedance	Voltage=10 KΩ Current=100 Ω

PNEUMATIC

Inlet Pressure	Full Vac - 190 psig
Pressure Range	Full Vac - 175 psig
Flow Rate	See Flow Graphs
Filtration Required	40 Micron
Accuracy (Pressure)	±0.2% F.S.
Hysteresis	±0.15% F.S.
Repeatability	±0.02% F.S.
Port Size	1/8" NPT Female
Critical Volume	1 in ³

Wetted Parts

Fluorocarbon, Brass, Nickel-Plated Brass,
 Silicon and Aluminum

PHYSICAL

Operating Temp	32 °F to 158 °F
Protection	NEMA 4/IP65
Weight	1.1 lbs.
Electrical Connector	6-pin Hirschman

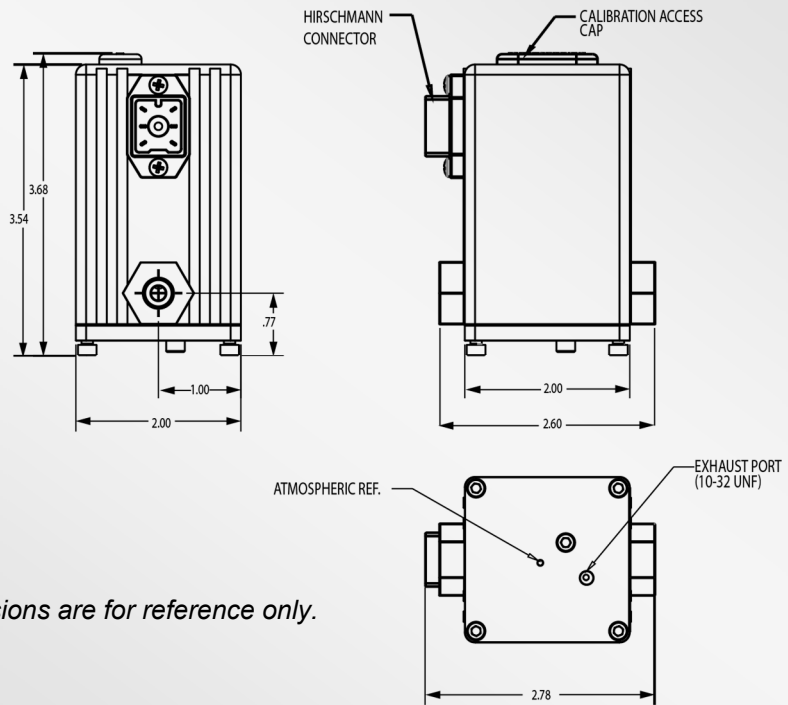

Dimensions are for reference only.
 Inches

- Precision pressure control vacuum to 175 psi (12 bar)
- Non-air consuming in steady state which reduces cost of manufacturing
- Can be mounted directly on the machine in any orientation
- Unaffected by shock or vibration
 Tested to 25 Gs
- Unaffected by supply pressure change

Access hole allows adjustments in the field. Easy tuning of Zero & Span calibration potentiometers

Available in a wide range of electrical control input and analog output

IP65 enclosure allows it to withstand the elements and be washed down without harm

Ships with required filtration

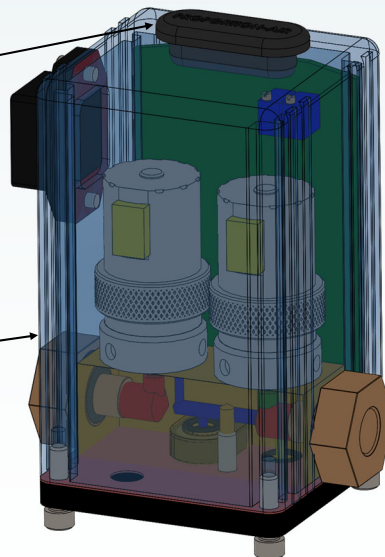

ACCURACY 0.2% F.S. (typical)

PRESSURE RANGE Full Vacuum to 175 psig (12 bar)



PORT SIZE 1/8"

MAX FLOW 1.2 scfm (34 slpm)

Example Part Number : QB 2 T B N E E N 14.7 P 150 PS G 3D TF

YOUR PART NUMBER : QB T

Section --> 1 2 3 4 5 6 7 8 9 10 11 Options

1 Type

- 1 Single Loop
- 2 Double Loop (external feedback, Option 3D)

2 Manifold Material

- B Brass (Typical)
- A 6061 Aluminum

3 Thread Type

- N NPT
- P BSPP

4 Input Signal Range

- E 0 to 10 Vdc
- I 4 to 20 mADC
- K 0 to 5 Vdc
- V 1 to 5 Vdc
- A RS 232 Serial Input*
- B RS 485 Serial Input*

*Requires X for Monitor Signal Range

5 Monitor Signal Range

- X No Monitor
- E 0 to 10 Vdc
- K 0 to 5 Vdc*
- V 1 to 5 Vdc*¹
- C 4 to 20 mADC (Sinking)
- S 4 to 20 mADC (Sourcing)

*Requires E, I, or K for Input Signal Range

*¹Requires V for Input Signal Range

6 Zero Offset

- N 0% Pressure Starts Below Atmosphere
- P 0% Pressure Starts Above Atmosphere
- Z 0% Pressure Starts at Zero (Typical)

7 Zero Offset Pressure

Typical is 0* - If Greater than 30% of Full Scale Pressure (#9 below) Please Consult Factory.

*If Z for Zero Offset (#6), please leave blank

8 Full Scale Pressure Type

- N 100% Pressure Ends Below Atmosphere
- P 100% Pressure Ends Above Atmosphere
- Z 100% Pressure Ends at Zero

9 Full Scale Pressure

Must be less than or equal to 175 psig

10 Pressure Unit

PS	PSI	Inches Hg	IH
MB	Millibars	Inches H ₂ O	IW
BR	Bar	mm H ₂ O	MW
KP	Kilopascal	Kilograms/cm ²	KG
MP	Megapascal	Torr*	TR
MH	mm Hg	Centimeters H ₂ O	CW

*Requires A for Pressure Unit of Measure

11 Pressure Unit of Measure

- A Absolute Pressure
- D Differential Pressure
- G Gage Pressure

PLEASE CONSULT FACTORY FOR MORE OPTIONS AND APPLICATION ASSISTANCE

Recommended Accessories

- QBT-C-6 6 ft. Power Cable
- QBT-01 Wrap-Around Bracket
- QBT-02 Foot-Mount Bracket (Installed)*

*Use Option BR for Foot-Mount Installed

Industrial Medical Machinery MFG* (NAICS 333298)

- Heart catheter manufacturing
- Catheter bag leak testing
- Stent medicine coating
- Air cuff (used to immobilize broken bones) leak testing
- Dispensing cell counting solution with differential pressure
- Low pressure catheter fill
- Surgeon suction wand
- Vacuum for orthopedic surgery
- Controlling oxygen in hyperbaric chamber

*Many applications require more flow than QB-series allows. We will pilot a mechanical regulator without sacrificing accuracy & repeatability for higher flow applications. Call us to discuss your opportunity.



QB1SS shown

ELECTRICAL

Supply Voltage	15 to 24 VDC
Supply Current	100 to 250 mADC
Command VDC	0 to 10 VDC
Command Current	4 to 20 mADC
Monitor VDC	0 to 10 VDC
Monitor Current	4 to 20 mADC
Command Signal Impedance	Voltage=10 KΩ Current=100 Ω

PNEUMATIC

Inlet Pressure	Full Vac - 550 psig
Pressure Range	Full Vac - 500 psig
Flow Rate	See Flow Graphs
Filtration Required	40 Micron
Accuracy (Pressure)	±0.25% F.S.
Hysteresis	±0.2% F.S.
Repeatability	±0.05% F.S.
Port Size	1/8" NPT Female
Critical Volume	1 in ³

Wetted Parts

Fluorocarbon, Brass, Nickel-Plated Brass,
Silicon and Aluminum

PHYSICAL

Operating Temp	32 °F to 158 °F
Protection	NEMA 4/IP65
Weight	1 lbs. 1.4 lbs. (SS)
Electrical Connector	6-pin Hirschman

DIMENSIONS ARE FOR REFERENCE USE ONLY

Inches (mm)

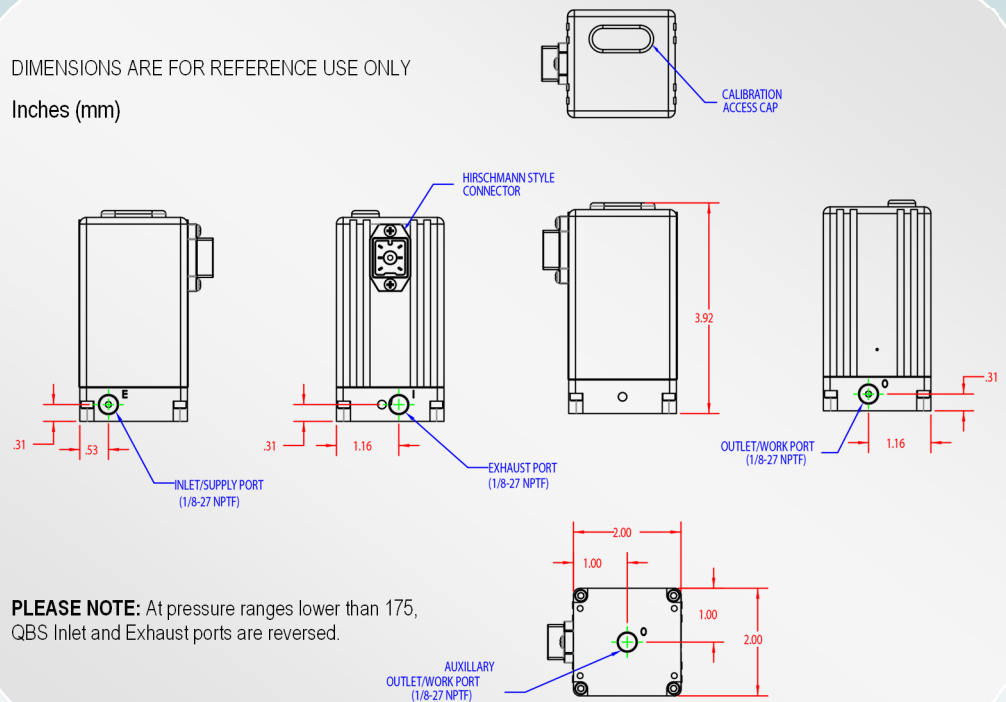

PLEASE NOTE: At pressure ranges lower than 175, QBS Inlet and Exhaust ports are reversed.

- Precision pressure control vacuum to 500 psi (34 bar)
- Available in a wide range of electrical control input and analog output
- Internal stainless steel pressure sensor, that utilizes dry technology instead of liquid fill, is used for increased reliability and media compatibility
- QBS available in anodized aluminum or stainless steel manifold which enhances media compatibility
- Two outlet ports which allows flexibility in mounting options.

Ships with required filtration

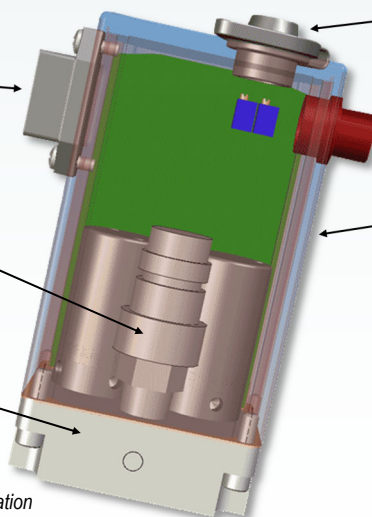

Access hole allows adjustments in the field. Easy tuning of Zero & Span calibration potentiometers

2nd loop input, QB2S valves only
Auxiliary connector (3D Option)

IP65 enclosure allows it to withstand the elements and be washed down without harm

• Unaffected by shock or vibration
Tested to 25 Gs

• Can be mounted directly on the machine in any orientation

• Non-air consuming in steady state which reduces cost of manufacturing

• Unaffected by supply pressure change

ACCURACY 0.25% F.S. (typical)

PRESSURE RANGE Full Vacuum to 500 psig (34 bar)

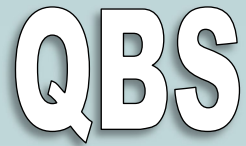

PORT SIZE 1/8"

MAX FLOW 1.2 scfm (34 slpm)

Example Part Number : **QB 2 S S N E E Z P 300 PS G 3D TF**

YOUR PART NUMBER : **QB** **S** **P**

Section → 1 2 3 4 5 6 7 8 9 10 11 Options

1 Type

1	Single Loop
2	Double Loop (external feedback)

2 Manifold Material

A	6061 Aluminum
S	303 Stainless Steel

3 Thread Type

N	NPT
P	BSPP

4 Input Signal Range

E	0 to 10 Vdc
I	4 to 20 mADC
K	0 to 5 Vdc
V	1 to 5 Vdc* ¹

*¹Requires V for Monitor Signal Range

5 Monitor Signal Range

X	No Monitor
E	0 to 10 Vdc
K	0 to 5 Vdc*
V	1 to 5 Vdc* ¹
C	4 to 20 mADC (Sinking)
S	4 to 20 mADC (Sourcing)

*Requires E, I, or K for Input Signal Range

*¹Requires V for Input Signal Range

6 Zero Offset

N	0% Pressure Starts Below Atmosphere
P	0% Pressure Starts Above Atmosphere
Z	0% Pressure Starts at Zero (Typical)

7 Zero Offset Pressure

Typical is 0* - If Greater than 30% of Full Scale Pressure (#9 below) Please Consult Factory.

*If Z for Zero Offset (#6), please leave blank

8 Full Scale Pressure Type

P	100% Pressure Ends Above Atmosphere
----------	-------------------------------------

9 Full Scale Pressure

Must be less than or equal to 500 psig

10 Pressure Unit

PS	PSI	Inches Hg	IH
MB	Millibars	Inches H ₂ O	IW
BR	Bar	mm H ₂ O	MW
KP	Kilopascal	Kilograms/cm ²	KG
MP	Megapascal	Torr*	TR
MH	mm Hg	Centimeters H ₂ O	CW

*Requires A for Pressure Unit of Measure

11 Pressure Unit of Measure

A	Absolute Pressure
G	Gage Pressure

PLEASE CONSULT FACTORY FOR MORE OPTIONS AND APPLICATION ASSISTANCE

Recommended Accessories

QBT-C-6	6 ft. Power Cable
QBT-01	Wrap-Around Bracket
QBT-02	Foot-Mount Bracket (Installed)*

*Use Option **BR** for Foot-Mount Installed

QBX

Proven Industries and Applications

Applicable to all QB Series Regulators

ELECTRICAL

Supply Voltage	15 to 24 VDC
Supply Current	100 to 250 mA _{DC(1)}
Command VDC	0 to 10 VDC
Command Current	4 to 20 mA _{DC}
Monitor VDC	0 to 10 VDC
Monitor Current	4 to 20 mA _{DC}
Command Signal Impedance	Voltage=10 K Ω Current=100 Ω

PNEUMATIC

Inlet Pressure	Full Vac - 190 psig
Pressure Range	Full Vac - 175 psig
Flow Rate	See Flow Graphs
Filtration Required	40 Micron
Accuracy (Pressure)	$\pm 0.2\%$ F.S.
Hysteresis	$\pm 0.15\%$ F.S.
Repeatability	$\pm 0.02\%$ F.S.
Port Size	1/8" NPT Female
Critical Volume	1 in ³

Wetted Parts

Fluorocarbon, Nickel-Plated Brass,
Silicon and Aluminum

PHYSICAL

Operating Temp	32 °F to 158 °F
Protection	NEMA 4/IP65 ₍₂₎
Weight	1.02 lbs.
Electrical Connector	6-pin Hirschman



Motor Vehicle Manufacturing* (NAICS 3361)

- Welding - seam welder force control
- Atomizing in the painting process
- Fuel pump flow test with back pressure control
- Tire & wheel assembly machines

Motor Vehicle Seating & Interior Trim MFG* (NAICS 33636)

- Dashboard and interior plastic painting
- Die lube spray in seat molds
- Calibration of car seat load cells for airbag deployment

*Many applications require more flow than QB-series allows. We will pilot a mechanical regulator without sacrificing accuracy & repeatability for higher flow applications. Call us to discuss your opportunity.

Dimensions are for reference only.
Inches [mm]

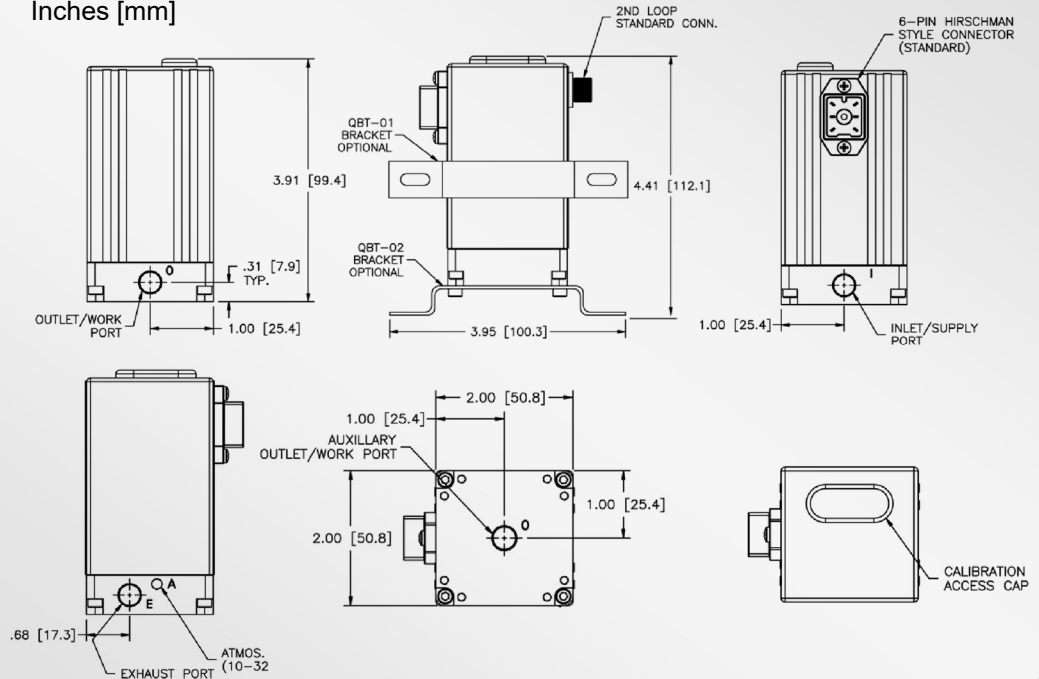

(1) Ethernet model max current is 350 mA

(2) Ethernet model is NEMA 1

See Page 10 for Ethernet Specifications

2nd loop input, QB2X valves only
Auxiliary connector (3D option)

- Non-air consuming in steady state which reduces cost of manufacturing
- Can be mounted directly on the machine in any orientation
- Precision pressure control vacuum to 175 psi (12 bar)
- Unaffected by shock or vibration - Tested to 20 Gs
- Unaffected by supply pressure change



M12 Ethernet Connections (Ethernet option only)

Access hole allows adjustments in the field. Easy tuning of Zero & Span calibration potentiometers

Available in a wide range of electrical control input and analog output

IP65 enclosure allows it to withstand the elements and be washed down without harm (Ethernet QBX is NEMA1)

Multiple inlet/outlet ports for a variety of different mounting configurations

Ships with required filtration

ACCURACY 0.2% F.S. (typical)

PRESSURE RANGE Full Vacuum to 175 psig (12 bar)



PORT SIZE 1/8"

MAX FLOW 1.2 scfm (34 slpm)

Example Part Number : QB 1 X A N E E N 14.7 P 150 PS G 3D TF

YOUR PART NUMBER : QB X A N

Section --> 1 2 3 4 5 6 7 8 9 10 11 Options

1 Type

- 1 Single Loop
- 2 Double Loop (external feedback)

2 Manifold Material

- A 6061 Aluminum

3 Thread Type

- N NPT

4 Input Signal Range

- E 0 to 10 Vdc
- I 4 to 20 mADC
- K 0 to 5 Vdc
- N Ethernet*
- V 1 to 5 Vdc*¹

*Requires N for Monitor Signal Range

*¹Requires V for Monitor Signal Range

5 Monitor Signal Range

- X No Monitor
- E 0 to 10 Vdc
- K 0 to 5 Vdc*
- N Ethernet*¹
- V 1 to 5 Vdc*²
- C 4 to 20 mADC (Sinking)
- S 4 to 20 mADC (Sourcing)

*Requires E, I, or K for Input Signal Range

*²Requires V for Input Signal Range

*¹Requires N for Input Signal Range

6 Zero Offset

- N 0% Pressure Starts Below Atmosphere
- P 0% Pressure Starts Above Atmosphere
- Z 0% Pressure Starts at Zero (Typical)

7 Zero Offset Pressure

Typical is 0* - If Greater than 30% of Full Scale Pressure (#9 below) Please Consult Factory.

*If Z for Zero Offset (#6), please leave blank

8 Full Scale Pressure Type

- N 100% Pressure Ends Below Atmosphere
- P 100% Pressure Ends Above Atmosphere
- Z 100% Pressure Ends at Zero

9 Full Scale Pressure

Must be less than or equal to 175 psig

10 Pressure Unit

PS	PSI (Ethernet Must Use PSI)	Inches Hg	IH
MB	Millibars	Inches H ₂ O	IW
BR	Bar	mm H ₂ O	MW
KP	Kilopascal	Kilograms/cm ²	KG
MP	Megapascal	Torr*	TR
MH	mm Hg	Centimeters H ₂ O	CW

*Requires A for Pressure Unit of Measure

11 Pressure Unit of Measure

- A Absolute Pressure
- G Gage Pressure

PLEASE CONSULT FACTORY FOR MORE OPTIONS AND APPLICATION ASSISTANCE

Recommended Accessories

- QBT-C-6 6 ft. Power Cable
- QBT-01 Wrap-Around Bracket
- QBT-02 Foot-Mount Bracket (Installed)*

*Use Option BR for Foot-Mount Installed

QBX Ethernet Description

The Ethernet QBX product is designed to receive commands and send pressure readings via an Ethernet TCP/IP connection. It contains a pc board which translates the Ethernet packets to analog signals for the analog control pc board.

The commands and data character are sent as ASCII printable characters except for the end of command terminator which is an ASCII carriage return (0d hex). Data cannot contain an alphabetic character, data delimiter or end of command terminator.

Command format:

CCC?n **or** CCC:ddd.dd?n

C	=	Command String
:	=	Command Delimiter
d	=	Data
\n	=	End of Command Terminator

Examples of commands are as follows:

complete information on the commands may be found in the QB1X/QB2X Ethernet Installation and Maintenance Instructions.

Set Pressure Command is "spc:120.70"
Valid Set Pressure Response is "spr:120.70"

Read Pressure Command is "rpc"
Valid Read Pressure Response is "rpr:120.75"

DIGITAL

COMMAND RESOLUTION	16 Bits
FEEDBACK RESOLUTION	16 Bits
COMMAND SIGNAL	DIGITAL

NETWORK INTERFACE

INTERFACE	Ethernet 10Base-T, Ethernet 100Base-TX (Autosensing)
PROTOCOLS	TCP/IP, UDP/IP, Telnet, BootP and AutoIP, DHCP
CONNECTOR	RJ45

INDICATORS (LED) ON RJ45 CONNECTOR

- 10Base-T Connection
- 100Base-TX Connection
- Link & Activity Indication
- Full/Half Duplex

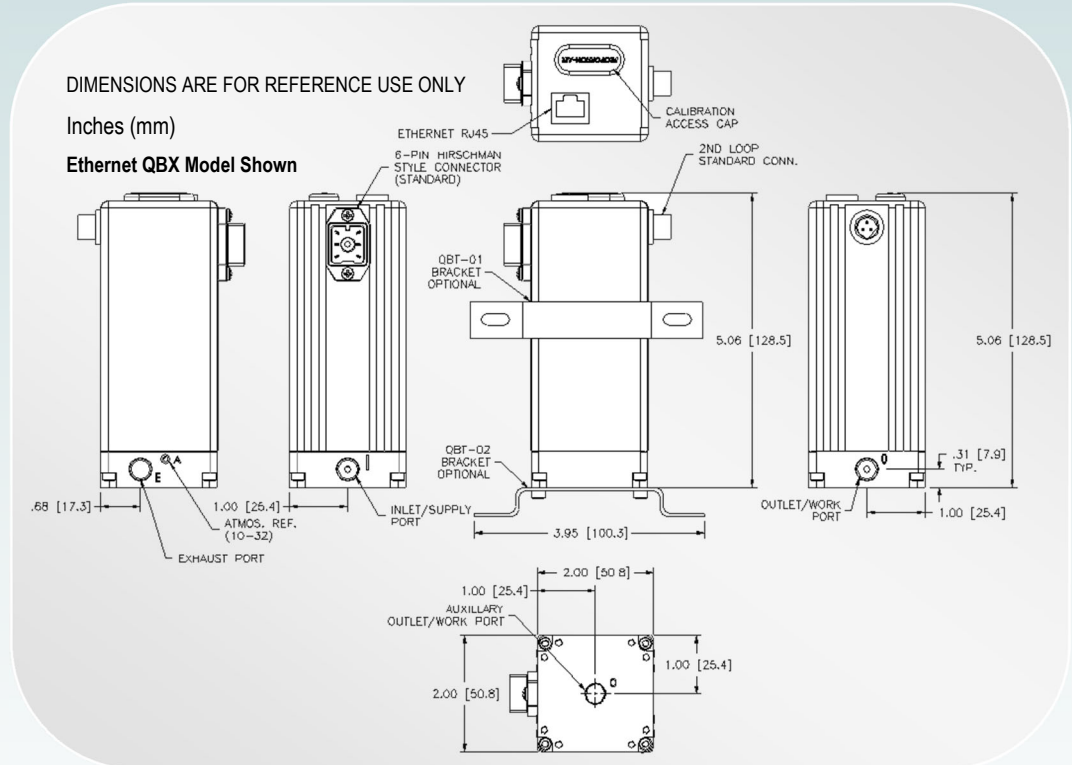

Proven Industries and Applications

Applicable to all QB Series Regulators

Aerospace Product & Parts Manufacturing* (NAICS 33641)

- Flight simulators - Pressure control on air cylinders to create resistance on yoke and pedals
- Military flight simulators - seat air bladders, seat belt tensioning and flight suit air bladders
- Pilot mask - final product testing using vacuum and positive pressure
- Cabin pressure leak testing - low positive pressure and rapid fill
- Emergency flotation vest leak testing using positive pressure
- Altimeter high pressure component & Pitot tube testing
- Aircraft fuselage fatigue testing
- Aircraft tire testing

*Many applications require more flow than QB-series allows. We will pilot a mechanical regulator without sacrificing accuracy & repeatability for higher flow applications. Call us to discuss your opportunity.



QB1X with Ethernet shown

Why DUAL-LOOP Technology?

ANY FLOW & ANY MEDIA

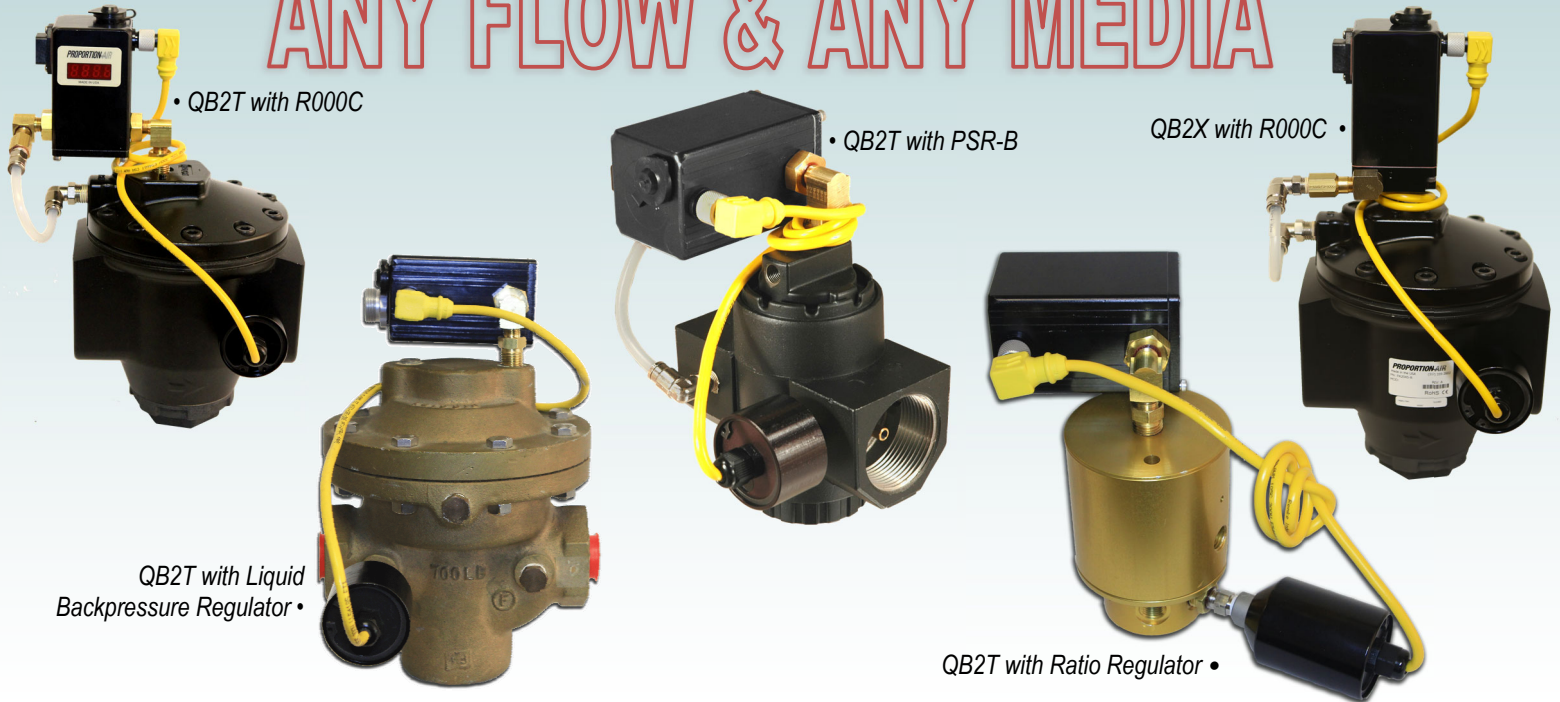

Dual loop technology: This provides us the capability to control *virtually* any media at any flow rate and any pressure without sacrificing accuracy and repeatability.

It also allows us to take feedback from more than just a pressure transducer. With a properly configured dual loop unit we can take feedback from a vacuum transducer, force transducer, torque, flow or position transducer.

PID loops no longer need tuned in your controller. Proportion-Air's dual loop technology makes proportional control easy. It is already done within the unique Proportion-Air analog circuit. You may need to ramp pressure (or vacuum, or force, or torque, or flow, or position) up and down – the QB2 will track the ramped signal from the PLC or computer and achieve the control setting required.

Accuracy: The downstream pressure transducer senses pressure on the work port of the pressure regulator and allows the QB2 to compensate for inaccuracy brought about by the mechanical properties of the regulator.

Repeatability: High flow capability, hydraulic or pneumatic media capability, more simple-to-use control and extremely repeatable: the same conditions with the same command signal from the same direction can have repeatability as high as 0.02% of full scale calibration.

High flow: Pressure reducing or back pressure regulators are available as large as 6 inch flange mount.

Data Acquisition: Just like other Proportion-Air electronic pressure regulators, the QB2 has an analog output that comes from the controlling transducer. This signal in a dual loop device comes from the downstream transducer.

ACCESSORIES

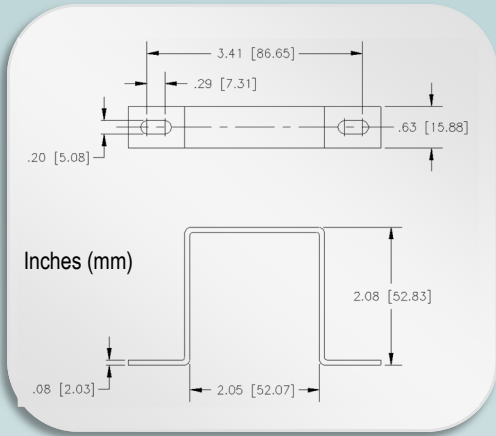

QBT-01

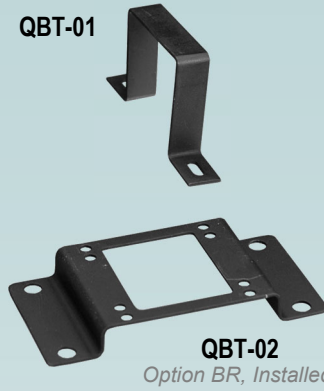

QBT-02

Option BR, Installed

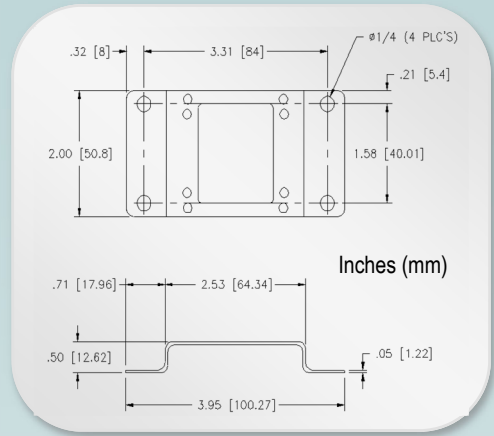

Inches (mm)

DIMENSIONS ARE FOR REFERENCE USE ONLY

QBT Power Cord



Pre-Assembled Power Cord

Part Number: **QBT-C-6** (typical)

LENGTH IN FEET
Other lengths are available
(from 1 to 25 feet (8 meters), 1 foot increments)

Give us a call or visit us on the web

ProportionAir.com

ONE PRODUCT THOUSANDS OF WAYS

Proportion-Air, Inc. 8250 N. 600 West, P.O. Box 218

McCordsville, Indiana USA 46055

Phone: 317-335-2602 Fax: 317-335-3853 info@proportionair.com

ProportionAir.com | 877.331.1738



Handcrafted in the USA
ISO 9001-2008 Certified



Proportion-Air products are warranted to the original purchaser only against defects in material or workmanship for one (1) year from the date of manufacture. The extent of Proportion-Air's liability under this warranty is limited to repair or replacement of the defective unit at Proportion-Air's option. Proportion-Air shall have no liability under this warranty where improper installation or filtration occurred.

All specifications are subject to change without notice. **THIS WARRANTY IS GIVEN IN LIEU OF, AND BUYER HEREBY EXPRESSLY WAIVES, WARRANTIES OR LIABILITIES, EXPRESS, IMPLIED OR STATUTORY, INCLUDING WITHOUT LIMITATION ANY OBLIGATION OF PROPORTION-AIR WITH REGARD TO CONSEQUENTIAL DAMAGES, WARRANTIES OF MERCHANTABILITY, DESCRIPTION, AND FITNESS FOR A PARTICULAR PURPOSE.**

WARNING: Installation and use of this product should be under the supervision and control of properly qualified personnel in order to avoid the risk of injury or death.