

SERVOTOUGH Laser 3 Plus - Tunable Diode Laser Single Path Spectrometer

THE SERVOTOUGH LASER 3 PLUS, NEXT-GENERATION TUNABLE DIODE LASER (TDL) SINGLE PATH SPECTROMETER, COMBINES UNIQUE FEATURES, LEADING PERFORMANCE AND REDUCED COST-OF-OWNERSHIP IN A REVOLUTIONARY COMPACT DESIGN.



SERVOTOUGH Laser 3 Plus

The SERVOTOUGH Laser 3 Plus is a revolution in TDL Absorption Spectroscopy analysis: a highly compact gas monitor for in-situ cross stack applications, which delivers exceptional performance benefits in a compact design.

Servomex's pioneering approach to design has produced an analyzer that occupies a footprint up to 1/10th the size of competitor products and includes an integrated display and key pad. This provides instant benefits in terms of installation ease and flexibility.

The SERVOTOUGH Laser 3 Plus delivers exceptional TDL performance with a fast response. Utilizing the latest Wavelength Modulated Spectroscopy (WMS) measurement techniques with advanced Servomex signal processing, the Laser 3 Plus provides stable and repeatable results with minimal installation and maintenance costs.

FLEXIBLE

- Compact design
- Performs in high particulate environments
- Path lengths from 0.1m to 25m *
- Minimal cross interference
- Diverse mounting: ideal for ducts and stacks
- Wide range of applications

EASY TO USE

- Simple to install and operate
- Robust and reliable
- Space saving
- Digital communications Modbus over Ethernet
- User friendly interface and rapid disconnect for easy calibration

LOW COST OF OWNERSHIP

- Intuitive alignment for easy installation and maintenance
- Non-depleting TDL technology
- No moving parts, no consumables
- No sample conditioning system - reduced maintenance costs

UNRIVALLED PERFORMANCE

- Process temperatures up to 1500°C *
- Low detection limit
- Negligible zero drift
- Calibration 6-12 months

BENCHMARK COMPLIANCE

- ATEX, IECEx hazardous area approvals
- North American hazardous area Class 1 Div 2
- IP66
- SIL 2
- CE approved

* Application and measurement dependent

WITH LINE LOCK TECHNOLOGY - SAFE, SECURE, RELIABLE

Learn more about the SERVOTOUGH Laser 3 Plus
VISIT SERVOMEX.COM



SERVOMEX.COM

PRODUCT OVERVIEW: Laser 3 Plus

A REVOLUTIONARY APPROACH TO TDL GAS ANALYSIS

By combining the latest advances in hardware with leading-edge software processing, the SERVOTOUGH Laser 3 Plus is a revolutionary step forward for TDL gas analysis. Servomex has approached TDL analysis afresh, creating an analyzer a fraction of the size without compromising performance. The result is TDL analysis that is easier and faster to install - saving valuable space while enabling much greater installation flexibility.

LOW MAINTENANCE, LOW COST-OF-OWNERSHIP

The next-generation ethos of the Laser 3 Plus works hard to reduce costs at all stages. In addition to the immediate advantages of TDL technology - a non-depleting measurement which requires no sample conditioning system - the Laser 3 Plus compact design greatly reduces installation time, with small, light intuitive alignment for easy installation and maintenance. Full ethernet communications for commissioning, diagnostics and trouble shooting.

HIGH PERFORMANCE MONITORING

The hardware advances of the Laser 3 Plus are matched by advanced Wave Length Signal Modulated Spectroscopy processing software which eliminates drift over extended operational periods by automatically tracking on a sealed reference cuvette absorption line - Line Lock Technology. This robust tracking mechanism ensures a highly reliable and accurate operation over long periods, with calibration frequencies extended beyond twelve months for many applications.

The result is a sturdy, general purpose and hazardous area optimized design which ensures Laser 3 Plus can handle the most challenging of locations; including particulate-rich environments.

LINE LOCK TECHNOLOGY - SAFE, SECURE, RELIABLE.

ALTERNATIVE PRODUCTS

The SERVOTOUGH product range features a number of options designed to meet your application needs.

FluegasExact 2700



Designed to measure O₂ and CO_e in flue gases for improved combustion efficiency and reduced emissions, the FluegasExact gas analyzer is designed to suit the most demanding needs of combustion efficiency applications in all combustion processes.

Oxy 1900



When you need high performance O₂ monitoring of flammable gases for applications like blanket inerting and flare stack analysis, choose the award winning Oxy; now augmented by innovative options including Flowcube flow measurement technology.

OxyExact 2200



The SERVOTOUGH OxyExact high specification oxygen analyzer offers an unrivalled combination of precision, flexibility and performance for optimum process and safety control. The OxyExact can be configured with a safe or hazardous area control unit with up to six transmitters.

KEY APPLICATIONS

- Process Heaters
- Incinerators
- Thermal Crackers
- Coal Mills
- ESP Protection
- Thermal Oxidizers
- Power Stations
- Furnaces
- Process Oxygen
- Ammonia Slip DeNO_x



PRODUCT OVERVIEW: Laser 3 Plus

MEASUREMENT	DETECTION LIMIT * \pm	MIN. RANGE \pm	MAX. RANGE \pm	MAX. PRESSURE BAR ABSOLUTE \pm	MAX. TEMPERATURE/°C \pm	MAX. PATH LENGTH \pm
O ₂	0.02%	0-1%	0-100%	2	1500	25m
NH ₃	0.2ppm	0-15ppm	150	1.2	600	10m
CO	1ppm	0-100ppm	0-10,000ppm	1.2	1500	25m
CH ₄	0.05%	0-5%	0-5%	1.2	500	25m
NOTES	* Detection limits are specified as the 95% confidence interval for 1m optical path and gas temperature/pressure = to 25°C/1 bar abs \pm Dependent on temperature, path length and dust. Refer to Servomex for application specific performance and limits.					

SPECIFICATION	
Technology	Single Line Tunable Diode Laser Spectroscopy
Optical path length *	0.1-25m
Measurement update rate	5 readings per second
T ₉₀ response time	Minimum 1 second
Zero drift	Negligible, <2% FSR between calibrations
Span drift	<4% FSR between calibrations
Linearity	<1% FSR
Calibration	Recommended every 6-12 months
Maintenance	Recommended every 12 months
Outputs and alarms	4-20 mA output: Isolated current loops, 500 Ω maximum 4-20 mA input: Maximum current 22mA input impedance 50 Ω Status Relays: 1A at 30V Vdc/ac
Digital communications	Modbus TCP/IP Ethernet (10 or 100 base)
Power supply	24V dc
Measurement availability	Optimal measurement availability via sealed reference cuvette and Servomex's unique line lock technology principle as standard.
NOTES	* Application dependent, on temperature, pathlength and dust. Refer to Servomex for further details.

FEATURES	
Pathlength specific optics	Optics are specified to ensure optimal measurement performance
Outputs and alarms options	Standard: 1 x 4-20 mA output, 1 x Status Relay Additional option Card: 1 x 4-20mA output, 2 x Status Relays, 2 x 4-20mA inputs
Flange sizes *	DN25, DN50, ANSI 1", 2", 3" and 4"
Sample wetted seals **	Viton 70 (standard) or Chemraz 505 (solvent resist)
In-line span cell *	Validation of reading
Accessories	Accessories such as alignment tools, calibration cell kits, purge panels and insertion tubes, isolation flanges and thermal spacers are available for specific applications – contact your local servomex business center
NOTES	* Application dependent ** Or equivalent

PRODUCT DATA: Laser 3 Plus

DEVICE SPECIFICATION

Size:

- TRANSMITTER:
131mm width (5¹/₈"")
164mm high (6¹/₂"")
302.4mm deep (11⁹/₁₀"")
- RECEIVER:
110mm width (4⁵/₁₆"")
146mm high (5³/₄"")
247.6mm deep (9³/₄"")

Weight:

- TRANSMITTER: <3.0 kg (6.6 lbs)
- RECEIVER: <2.0 kg (4.4 lbs)

Operating temperature:

- -20°C to +65°C (standard)

Certifications:

- ATEX Cat 3 (Gases)
- ATEX Cat 21 (Dust)
- IECEx Zone 2 and Zone 21
- North American Class 1 Division 2 and Zone 2 (Gas and Dust)
- Safe Area / General Purpose
- CE marked in compliance with ATEX, EMC, LVD and all other applicable directives

Protection Class:

- IP66
- NEMA 4X

These analyzers are not intended for any form of use on humans and are not medical devices as described in the Medical Devices Directive 93/42/EEC.

DEVICE SCHEMATIC

Transmitter

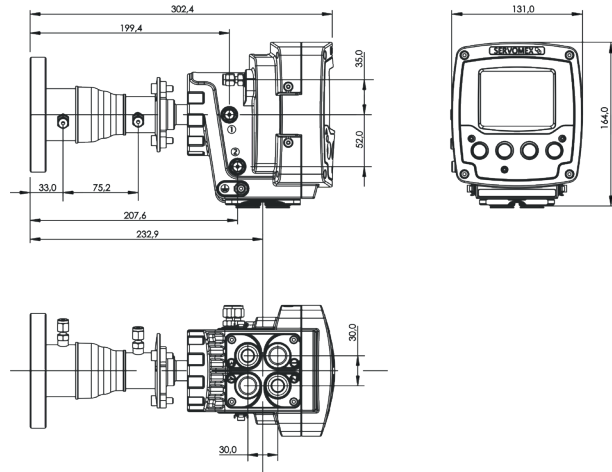

Receiver

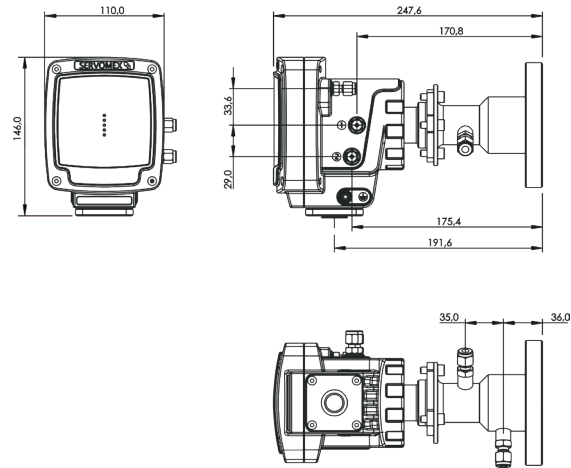

Please note: While every effort has been made to ensure accuracy, no responsibility can be accepted for errors or omissions. Data may change, as well as legislation, and you are strongly advised to obtain copies of the most recently issued regulations, standards and guidelines. This document is not intended to form the basis of a contract.

AMERICAS BUSINESS CENTER
Tel: +1 281 295 5800
Email: americas_sales@servomex.com

ASIA PACIFIC BUSINESS CENTRE
Tel: +86 (0)21 6489 7570
Email: asia_sales@servomex.com

EUROPEAN BUSINESS CENTRE
Tel: +44 (0) 1892 603330
Email: europe_sales@servomex.com

INDIA BUSINESS CENTRE
Tel: +91 22 3934 2700
Email: MEI_sales@servomex.com

MIDDLE EAST BUSINESS CENTRE
Tel: +971 6552 8073
Email: MEI_sales@servomex.com