



FLOWSIC100 Flare

NEXT GENERATION SENDER AND RECEIVER UNIT

Gas flow measuring instruments

SICK
Sensor Intelligence.

THE RIGHT SOLUTION FOR EVERY CHALLENGE





Dealing with difficult flare gas conditions the requirements for measuring technology pose a challenge in the oil and gas and the chemical and petrochemical industry:

- Gas velocities of 0 to 120 m/s
- Rapid changes in the gas velocity
- Rapidly changing gas mixtures natural gas, hydrogen, carbon dioxide, etc.

Ultrasonic flow meters continue to set the standard in flow measurement when it comes to dynamic range and accuracy. SICK has developed a new generation of ultrasonic measuring devices that work completely reliably and accurately even under extreme conditions and are installed in next to no time.

The new generation of FLOWSIC100 Flare sender and receiver units are available in five different versions. Whether the application's complex gas compositions or specific installation conditions pose a challenge, reliable gas flow measurement is ensured at all times.

The sender and receiver units are available as a 1- or 2-path measurement system. The 2-path version achieves high measurement accuracies even under difficult flow conditions. Cross-duct installation and single nozzle probe systems are available in either path configuration. The probe and 90° installation version is suitable for compact, one-sided fitting, which minimizes the installation work required. A device retraction mechanism also allows sensors to be replaced simply and quickly during plant operation.

	F1F-S	F1F-M	F1F-H	F1F-R	F1F-P
					
Type	Cross-duct measurement			90° Installation	Probe
Number of possible measuring paths	1-path / 2-path				
Pipe size 1-path	4" - 18"	20" - 40"	42" - 72"	18" - 72"	12" - 72"
Pipe size 2-path	12" - 18"				18" - 72"
Equipment Protection Level	Intrinsic safety		Flameproof	Intrinsic safety	
Speciality	Suitable for low-temperature applications		-	Suitable for low-temperature applications	
	Powerful, hermetically sealed titanium sensors				
	-	-	For complex gas compositions and challenging application conditions	Single side installation, only one side access required	Single side installation, only one side access required. Only single weld-on nozzle.

LEADING ULTRASONIC TECHNOLOGY, WITHSTANDS EVERY SITUATION

SICK-quality sensor technology

Thanks to advanced signal processing, the hermetically sealed high-performance ultrasonic sensor allows a very high resolution of the signals and measures reliably and accurately even at very low gas velocities close to zero.

The new ultrasonic sensors are also capable of performing measurements even under extreme conditions, with varying gas compositions and at high flow velocities. Developed specially for use at very high gas flows, measurement is also continuously available in the event of extreme background noise, gas turbulence and emergency shutdown.

Precise measurement even at very low gas velocities close to zero

Hermetically sealed ultrasonic sensors made of titanium

Above-average availability and resistance even under extreme measurement conditions

Patented, flow-optimized sensor design



Patented ASC-technology

Ensuring measurement availability even at the highest gas velocities is one of the most important characteristics of a flare measurement system. Thanks to its innovative ASC-technology (active sound correlation technology), FLOW SIC100 Flare is

now extending previous maximum flow range by up to 30%. ASC correlates the gas velocity with application-specific noise generated at high flow conditions. The patented ASC-technology thus allows an even better coverage of possible flare gas events.

Flow measurement with Ultrasonic transit time difference measurement			Flow measurement with ASC-technology
The state-of-the-art electronics precisely detects even very small transit time differences.	The ultrasonic sensors made of titanium are long-term stable and allow safe and reliable operation.	The innovative, flow optimized sensor contour allows optimal measurement results even at very high gas velocities.	If the signal is blown away due to extreme gas velocity, the patented ASC-technology algorithm ensures uninterrupted measurement.

Detailed technical data

The exact device specifications and performance data of the product may deviate from the information provided here, and depend on the application in which the product is being used and the relevant customer specifications. Please contact your local SICK representative to inquire about the FLOWSIC100 Flare performance for your application.

General technical information for ultrasonic sensors

Ambient temperature	Sensors, ignition group IIC T4 Sensors, ignition group IIC T4 Optional Sensors, ignition group IIC T6 Sensors, ignition group IIC T6 Optional	-40 °C ... +70 °C -50 °C ... +70 °C -40 °C ... +55 °C -50 °C ... +55 °C Optional
Storage temperature		-40 °C ... +70 °C -50 °C ... +70 °C Optional
Enclosure rating		IP66 / IP67
Weight		F1F-S/ F1F-R: ≤ 12 kg (pair of ultrasonic sensors) F1F-M: ≤ 12 kg (pair of ultrasonic sensors) F1F-H: ≤ 14 kg (pair of ultrasonic sensors) F1F-P: ≤ 10 kg (pair of ultrasonic sensors)
Dimensions (W x H x D)		For details see dimensional drawings

F1F-S / F1F-R

Operating pressure ¹	CL150 device flange PN25 device flange (optional) CL300 device flange (optional)	20 bar(g) 20 bar(g) 20 bar(g)
		¹ Temperature dependent. For details, see section Application ranges.
Ex-approvals	IECEx ATEX NEC/CEC (US/CA)	Ex db [ia Ga] IIC T6 Ga/Gb Ex db [ia Ga] IIB T4 Ga/Gb Ex db [ia Ga] IIA T4 Ga/Gb II 1/2G Ex db [ia Ga] IIC T6 Ga/Gb II 1/2G Ex db [ia Ga] IIC/IIB/IIA T4 Ga/Gb CI I, Div1 Group B, C, D, T4; CI I, Zone 1, Ex/AEx d [ia] IIB + H2, T4 CI I, Div2 Group A, B, C, D, T4; CI I, Zone 2, Ex/AEx nA [ia] IIC, T4
Gas temperature		-196 °C ... +280 °C

F1F-M

Operating pressure ¹	CL150 device flange PN25 device flange (optional) CL300 device flange (optional)	20 bar(g) 20 bar(g) 20 bar(g)
		¹ Temperature dependent. For details, see section Application ranges.

Ex-approvals	IECEX	Ex db [ia Ga] IIC T6 Ga/Gb Ex db [ia Ga] IIB T4 Ga/Gb Ex db [ia Ga] IIA T4 Ga/Gb
	ATEX	II 1/2G Ex db [ia Ga] IIC T6 Ga/Gb II 1/2G Ex db [ia Ga] IIC/IIB/IIA T4 Ga/Gb
	NEC/CEC (US/CA)	CI I, Div1 Group C, D T4; CI I, Zone 1, Ex/AEx d [ia] IIB + H2, T4 CI I, Div2 Group C, D T4; CI I, Zone 2, Ex/AEx nA [ia] IIC, T4
	Gas temperature	

F1F-H

Operating pressure ¹	CL150 device flange	ATEX/IECEX: 20 bar(g) CSA: 16 bar(g)
	PN25 device flange (optional)	ATEX/IECEX: 20 bar(g) CSA: 16 bar(g)
	CL300 device flange (optional)	ATEX/IECEX: 20 bar(g) CSA: 16 bar(g)
	¹ Temperature dependent. For details, see section Application ranges.	
Ex-approvals	IECEX	Ex db IIC T6/T4 Gb Ex db eb IIC T6/T4 Gb
	ATEX	II 2G Ex db IIC T6/T4 Gb II 2G Ex db eb IIC T6/T4 Gb
	NEC/CEC (US/CA)	CI I, Div1 Group B, C, D T4 CI I, Zone 1, Ex/AEx d IIB + H2, T4 CI I, Div2 Group A, B, C, D T4 CI 1, Zone 2, Ex/AEx nA IIC, T4
	Gas temperature	

F1F-P

Operating pressure ¹	CL150 device flange	ATEX/IECEX: 20 bar(g) CSA: 16 bar(g)
	PN25 device flange (optional)	ATEX/IECEX: 20 bar(g) CSA: 16 bar(g)
	CL300 device flange (optional)	ATEX/IECEX: 20 bar(g) CSA: 16 bar(g)
	¹ Temperature dependent. For details, see section Application ranges.	
Ex-approvals	IECEX	Ex db [ia Ga] IIC T6 Ga/Gb Ex db [ia Ga] IIB T4 Ga/Gb Ex db [ia Ga] IIA T4 Ga/Gb
	ATEX	II 1/2G Ex db [ia Ga] IIC T6 Ga/Gb II 1/2G Ex db [ia Ga] IIC/IIB/IIA T4 Ga/Gb
	NEC/CEC (US/CA)	CI I, Div1 Group B, C, D T4; CI I, Zone 1, Ex/AEx d [ia] IIB + H2 T4 CI I, Div2 Group A, B, C, D T4; CI I, Zone 2 Ex/AEx nA [ia] IIC, T4
	Gas temperature	

Ordering information

Our regional sales organization will be glad to advise you on which device configuration is best for you.

Applications of FLOWSIC100 Flare in regulated environment

The gas flow measuring instrument can be applied in emission measurements which may be subject to one or more regulations in some jurisdictions. Compliance to all emissions regulations applicable at the installation site remains owner / operator responsibility. If designed and applied correctly SICK's ultrasonic flow technology will meet or exceed most performance requirements set forth by any regulatory authority. Please contact your SICK representative to inquire about the correct flare measurement solution which will meet the currently applicable requirements set forth by the authorities.

Dimensional drawings (dimensions in mm)

F1F-S/M/H

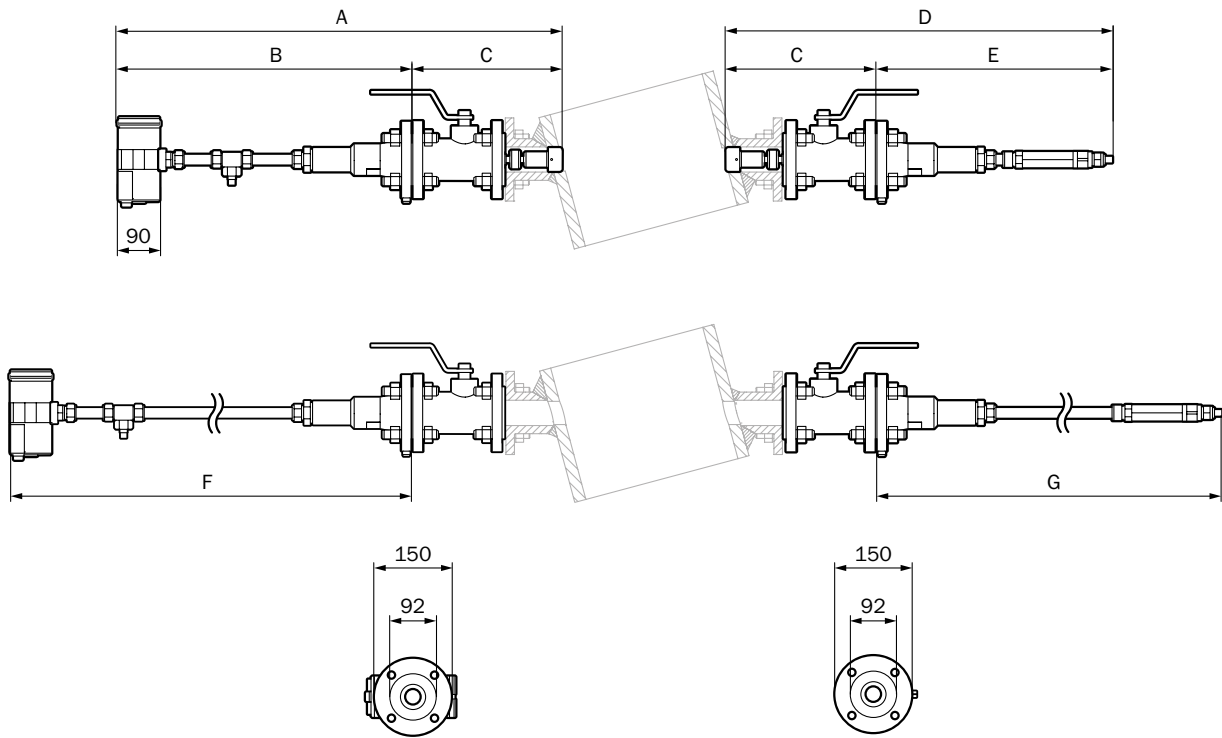

Flare	Dimensions						
	A	B	C	D	E	F	G
F1F-S	883	583	300	771	471	955.5	844
F1F-M	880	582	298	769	471	884	773
F1F-H	746	448	298	816	518	751.5	817

F1F-P

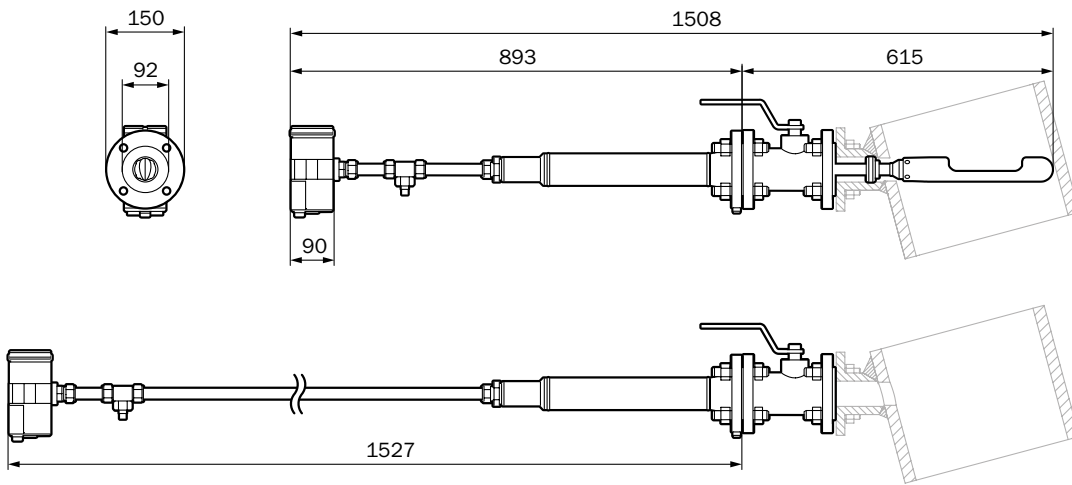

F1F-R

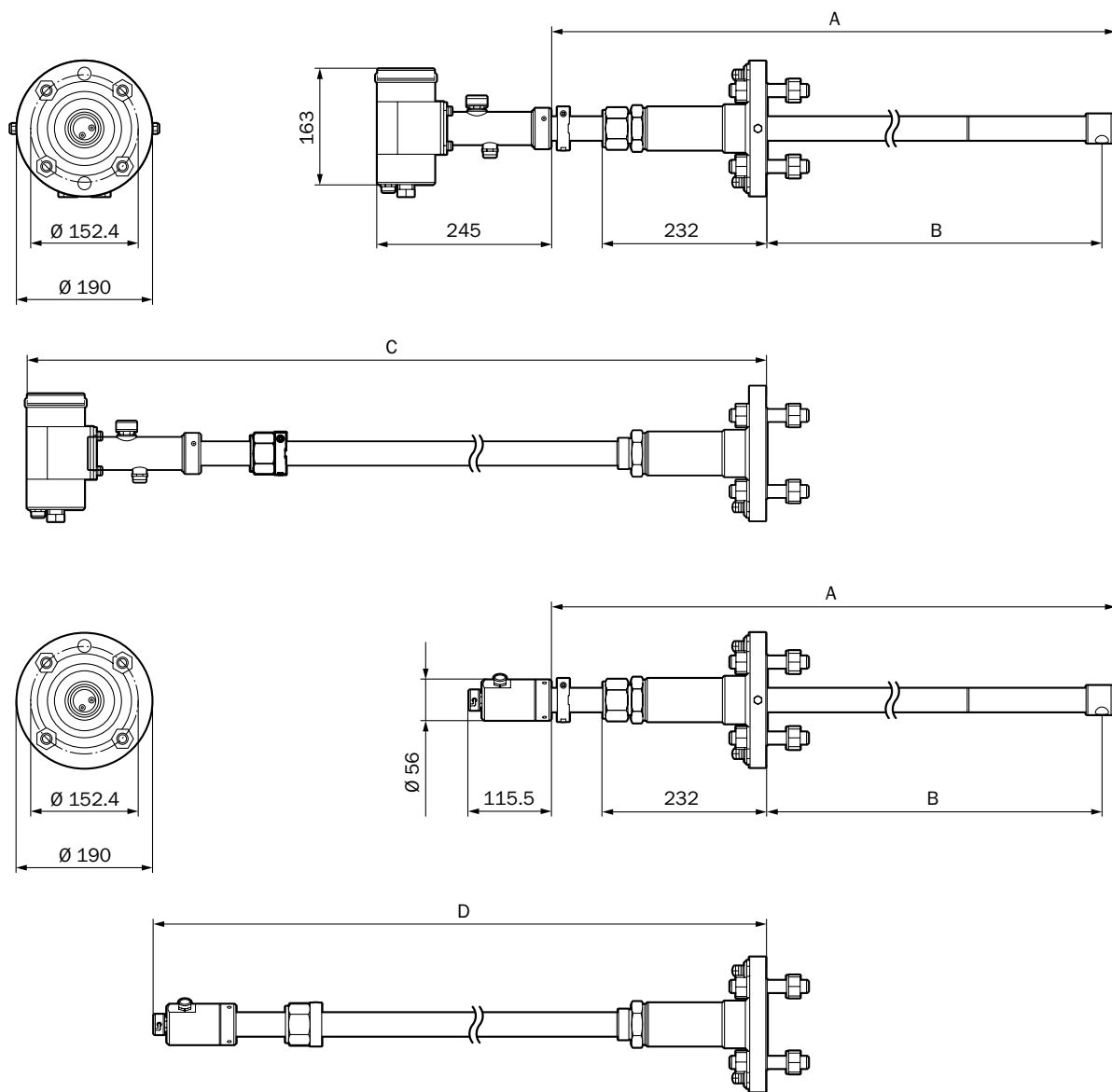

Nominal pipe size	Dimensions			
	A	B	C	D
12" - 24"	800	475	1048	869
26" - 48"	922	597	1170	991
50" - 72"	1044	719	1292	1113

REGISTER AT WWW.SICK.COM TO TAKE ADVANTAGE OF OUR FOLLOWING SERVICES FOR YOU





- ✔ Access information on net prices and individual discounts.
- ✔ Easily order online and track your delivery.
- ✔ Check your history of all your orders and quotes.
- ✔ Create, save, and share as many wish lists as you want.
- ✔ Use the direct order to quickly order a big amount of products.
- ✔ Check the status of your orders and quotes and get information on status changes by e-mail.
- ✔ Save time by using past orders.
- ✔ Easily export orders and quotes, suited to your systems.

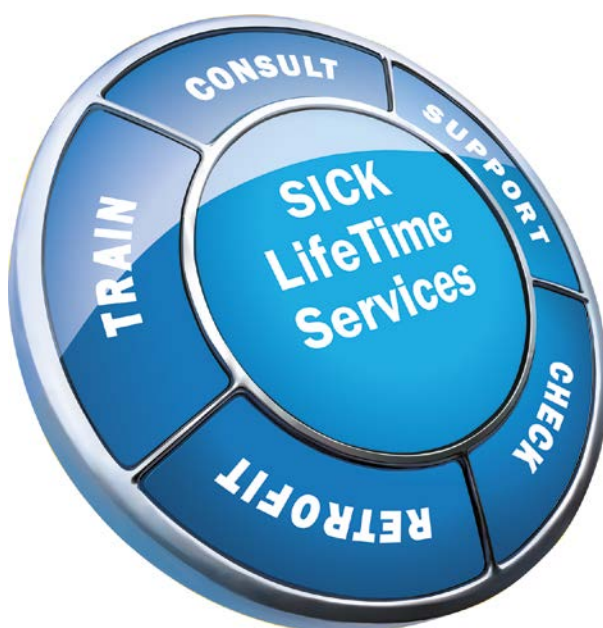

SERVICES FOR MACHINES AND PLANTS: SICK LifeTime Services

Our comprehensive and versatile LifeTime Services are the perfect addition to the comprehensive range of products from SICK. The services range from product-independent consulting to traditional product services.



- 
Consulting and design
 Safe and professional
- 
Product and system support
 Reliable, fast, and on-site
- 
Verification and optimization
 Safe and regularly inspected
- 
Upgrade and retrofits
 Easy, safe, and economical
- 
Training and education
 Practical, focused, and professional

SICK AT A GLANCE

SICK is a leading manufacturer of intelligent sensors and sensor solutions for industrial applications. With more than 9,700 employees and over 50 subsidiaries and equity investments as well as numerous agencies worldwide, SICK is always close to its customers. A unique range of products and services creates the perfect basis for controlling processes securely and efficiently, protecting individuals from accidents, and preventing damage to the environment.

SICK has extensive experience in various industries and understands their processes and requirements. With intelligent sensors, SICK delivers exactly what the customers need. In application centers in Europe, Asia, and North America, system solutions are tested and optimized in accordance with customer specifications. All this makes SICK a reliable supplier and development partner.

Comprehensive services round out the offering: SICK LifeTime Services provide support throughout the machine life cycle and ensure safety and productivity.

That is “Sensor Intelligence.”

Worldwide presence:

Australia, Austria, Belgium, Brazil, Canada, Chile, China, Czech Republic, Denmark, Finland, France, Germany, Great Britain, Hungary, Hong Kong, India, Israel, Italy, Japan, Malaysia, Mexico, Netherlands, New Zealand, Norway, Poland, Romania, Russia, Singapore, Slovakia, Slovenia, South Africa, South Korea, Spain, Sweden, Switzerland, Taiwan, Thailand, Turkey, United Arab Emirates, USA, Vietnam.

Detailed addresses and further locations → www.sick.com