

ZIRKOR200 Ex-G

Oxygen Analyzer

SICK
Sensor Intelligence.



Described product

Product name: ZIRKOR200 Ex-G

Manufacturer

SICK AG
Erwin-Sick-Str. 1 · D-79183 Waldkirch · Germany
Phone: +49 7641 469-0
Fax: +49 7641 469-1149
E-mail: info.pa@sick.de

Legal information

This work is protected by copyright. Any rights derived from the copyright shall be reserved for SICK AG. Reproduction of this document or parts of this document is only permissible within the limits of the legal determination of Copyright Law.

Any modification, shortening or translation of this document is prohibited without the express written permission of SICK AG.

The trademarks stated in this document are the property of their respective owner.

© SICK AG. All rights reserved.

Original document

This document is an original document of SICK AG.

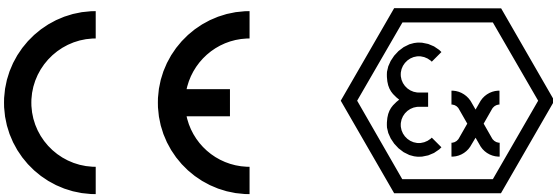

Contents

1	About this document.....	8
1.1	Function of this document.....	8
1.2	Scope of application	8
1.3	User qualification	8
1.4	Further information	8
1.5	Symbols and document conventions	9
1.5.1	Warning symbols.....	9
1.5.2	Warning levels and signal words.....	9
1.5.3	Information symbols	10
1.6	Data integrity	10
2	For your safety.....	11
2.1	Basic safety information	11
2.2	Warning information on device	12
2.3	Intended use	13
2.3.1	Purpose of the device.....	13
2.3.2	Operation in potentially explosive atmospheres	13
2.3.3	Restrictions of use	15
2.4	Responsibility of user.....	16
2.4.1	Designated users.....	16
2.4.2	Correct project planning.....	16
2.4.3	Correct use.....	16
2.4.4	Special local conditions.....	16
2.4.5	Read the Operating Instructions	16
3	Product description	17
3.1	Product identification	17
3.2	Type plates	17
3.3	Device versions	20
3.4	Device variants.....	23
3.5	Options	23
3.6	Expansion modules.....	23
4	Layout and function.....	24
4.1	System overview.....	24
4.2	Measuring principle	26
4.3	Scope of application	26
4.4	Potential hazards	26
4.5	Process interruption.....	26
4.6	Pneumatic unit.....	27
4.7	Explosion protection description - ignition protection types	27
4.7.1	Ignition protection type “flameproof enclosure” Ex “d”	27
4.7.2	Ignition source monitoring of the analyzer unit by means of temperature monitoring	30
4.7.3	Ignition protection types on solenoid valves	30

- 5 Installation 31**
 - 5.1 Determination of the requirements for explosion protection 31
 - 5.2 Information on installation in potentially explosive atmospheres..... 31
 - 5.3 Tools required 33
 - 5.4 Material required 33
 - 5.5 Preparing the measuring point 33
 - 5.6 Transport..... 33
 - 5.7 Storage information..... 34
 - 5.8 Scope of delivery 34
 - 5.9 Installation 34
 - 5.9.1 Fitting the counter flange on the duct 35
 - 5.9.2 Installing the control unit 35
 - 5.9.3 Fitting the analyzer unit 36
 - 5.9.4 Fitting the analyzer unit with cooling protection pipe..... 38
 - 5.9.5 Installing the analyzer unit..... 38
 - 5.9.6 Aligning the V-shield..... 39
 - 5.9.7 Laying the connection cable 40
 - 5.9.8 Installing connection cables 41
 - 5.9.9 Fitting the pneumatic unit..... 42
 - 5.10 Electrical installation 43
 - 5.10.1 Accessing the connection terminals 44
 - 5.10.2 Instructions for the function of the spring-loaded terminal 44
 - 5.10.3 Potential equalization, (PE, ground) 44
 - 5.10.4 Connecting the control unit 45
 - 5.10.5 Electrical connection plan (Ex-control unit and Ex-analyzer unit)..... 46
 - 5.10.6 Power connection..... 48
 - 5.10.7 Connecting the connection cable to the control unit 49
 - 5.10.8 Connecting the valve cable of the analyzer unit to the control unit 49
 - 5.10.9 Connecting the pneumatic unit line to the control unit 49
 - 5.10.10 Outputs/functions and relay assignment..... 49
 - 5.10.11 Digital inputs 50
 - 5.10.12 Installing connection cables 50
 - 5.10.13 Connecting the connection cable 50
 - 5.10.14 Connecting the analyzer electronics to the connection cable ... 52
 - 5.10.15 Connecting the valve cable of the analyzer unit to the solenoid valve..... 53
 - 5.10.16 Connecting the pneumatic unit to the solenoid valve 53
 - 5.10.17 Closing the enclosure..... 53
 - 5.11 Pneumatic connections and settings 54
 - 5.11.1 Pneumatic hose requirements 54
 - 5.11.2 Preparing the pneumatic hose 54
 - 5.11.3 Pneumatic connections on the analyzer unit..... 54

5.11.4	Pneumatic connection, pneumatic unit semi-automatic or fully automatic	55
5.11.5	Test air volumes and reference air volume	55
5.11.6	Setting the flow volume	55
6	Commissioning	56
6.1	Safety information on commissioning.....	56
6.2	Checklist before initial commissioning of the system	56
6.3	Operation.....	57
6.4	Initial commissioning	58
6.5	Display - heating process.....	58
6.6	Display - Measuring mode	58
6.7	Operating elements and display.....	59
6.8	Status LEDs	59
6.9	Softkey symbols	59
6.10	System code	59
7	Menu overview and explanations.....	60
7.1	SYS-MENU	60
7.2	Menu explanations.....	63
7.2.1	O ₂ measuring ranges (scaling).....	63
7.2.2	Measured value average over [s].....	63
7.2.3	mA output for system error	63
7.2.4	O ₂ limit value alarms	64
7.2.5	O ₂ sensor adjustment values.....	64
7.2.6	Time per test gas feed.....	64
7.2.7	Stopping time until process (O ₂)	65
7.2.8	Auto. Adjustment (ACAL)	65
7.2.9	Settings for auto. adjustment	65
7.2.10	REMOTE	66
7.2.11	Units of measure	66
7.2.12	Language.....	66
7.2.13	Change system code	67
7.2.14	Loading the factory settings.....	67
7.2.15	Service (factory service settings)	67
7.2.16	Adjustment menu	67
7.2.17	Display - Adjustment.....	67
7.2.18	1-point adjustment (manual)	68
7.2.19	2-point adjustment (manual)	69
7.3	System check	70
8	Maintenance.....	71
8.1	Technical knowledge necessary for maintenance work.....	71
8.2	Safety instructions for maintenance work	71
8.3	Information on use in Ex-areas	72
8.4	Maintenance plan	72

8.5	Tools required	73
8.6	Maintenance work	73
8.6.1	Replace fuses	73
8.6.2	Replacing the filter head	74
8.6.3	Replacing an analyzer unit	74
8.6.4	Replacing the O ₂ measuring cell	75
8.6.5	Replacing the inner part of the analyzer unit.....	76
8.6.6	Visual check of the flameproof enclosure.....	76
8.6.7	Stability criteria during adjustment	77
9	Status messages	78
9.1	Error messages.....	78
9.2	Alarm messages	80
9.3	Maintenance messages	80
10	Heating shutdown in case of malfunction	81
10.1	General information	81
10.2	Functional description.....	82
10.3	Maintenance.....	82
11	Troubleshooting	83
11.1	Strongly fluctuating O ₂ measured value	83
11.2	O ₂ display remains at end of measuring range or is higher than expected	83
11.3	Indications on the display are OK, mA output signal is not correct	83
11.4	O ₂ display on 0%, although the operating mode indicates a higher O ₂ value	84
12	Decommissioning.....	85
12.1	Safety information on decommissioning.....	85
12.2	Shutdown procedure	86
12.3	Removing the device	86
12.4	Environmentally compatible disposal.....	86
13	Technical data.....	87
13.1	Dimension drawings	87
13.1.1	Dimension sheets of the control unit	87
13.1.2	Dimension sheets of the analyzer unit.....	88
13.1.3	Counter flange dimensions.....	90
13.1.4	Dimension of protective pipe flanges.....	90
13.1.5	Analyzer unit components	91
13.1.6	Dimension sheets of the pneumatic unit.....	93
13.1.7	Display board.....	95

13.2	Technical data	96
13.2.1	Installation location	96
13.2.2	Technical data of the control unit	96
13.2.3	Technical data of the analyzer unit	97
13.2.4	Data of the external pneumatics	97
13.2.5	Technical specification for the gas supply.....	98
13.3	Tightening torques for Ex-relevant screw fittings	99

1 About this document

1.1 Function of this document

These Operating Instructions describe:

- Device components
- Installation
- Operation
- Maintenance work required for reliable operation
- Decommissioning

1.2 Scope of application

These Operating Instructions are only applicable for the measuring device described in the product identification.

They are not applicable for other SICK measuring devices.

The standards referred to in these Operating Instructions are to be observed in the respective valid version.

1.3 User qualification

These Operating Instructions are intended for persons installing, operating and maintaining the device.

Table 1: Qualification requirements

Work	User groups	Qualification
Installation	Operator / system integrator	<ul style="list-style-type: none"> • E.g. plant operator, untrained in measurement technology • Qualification for explosion protection
Electrical installation	Qualified personnel	<ul style="list-style-type: none"> • Authorized electrician (authorized skilled electrician or person with similar training) • Qualification for explosion protection
Initial commissioning	Authorized operator ☹	<ul style="list-style-type: none"> • General knowledge of measurement technology, device expertise (customer training at SICK if necessary) • Qualification for explosion protection
Recommissioning		
Decommissioning	<ul style="list-style-type: none"> • Operator / system integrator • Authorized operator ☹ 	<ul style="list-style-type: none"> • E.g. plant operator, untrained in measurement technology • Authorized electrician (authorized skilled electrician or person with similar training) • Qualification for explosion protection
Operation		
Maintenance		
Troubleshooting		

1.4 Further information









Observe the supplied documents.

- Final inspection record ZIRKOR200 Ex-G
- USB stick with technical information and certificates
- Manual for solenoid valve/test gas
- Data sheets for 1/2" NPT and 3/4" NPT screw fitting
- Processing instructions for sealing compound, screw fittings

1.5 Symbols and document conventions

1.5.1 Warning symbols

Table 2: Warning symbols

Symbol	Significance
	Hazard (general)
	Hazard by electrical voltage
	Hazard in potentially explosive atmospheres
	Hazard by explosive substances/mixtures
	Hazard by oxidizing substances
	Hazard by toxic substances
	Hazard by unhealthy substances
	Hazard by high temperature or hot surfaces
	Hazard for environment/nature/organisms

1.5.2 Warning levels and signal words

DANGER:

Risk or hazardous situation which *will* result in severe personal injury or death.

WARNING:

Risk or hazardous situation which *could* result in severe personal injury or death.

CAUTION:

Hazard or unsafe practice which *could* result in less severe or minor injuries.



NOTICE:

Hazard which *could* result in property damage.

Note:

Hints

1.5.3 Information symbols

Symbol	Significance
	Information on the nature of the product in relation to Directive 2014/34/EU for devices and protective systems intended for use in potentially explosive atmospheres
	Important technical information for this product
	Important information for electrical or electronic functions

1.6 Data integrity

SICK AG uses standardized data interfaces, such as standard IP technology, in its products. The focus here is on product availability and features.

SICK AG always assumes that the customer is responsible for the integrity and confidentiality of data and rights involved in connection with using the products.

In all cases, the customer is responsible for the implementation of safety measures suitable for the respective situation, e.g., network separation, firewalls, virus protection and patch management.

2 For your safety

2.1 Basic safety information

Work on the device



DANGER: Danger of explosion

Danger of explosion when working on the device.

- ▶ Ensure no explosive atmosphere is present when working on the device.
- ▶ Make sure the stack is switched off.



DANGER: Danger of explosion through explosive mixture in the components

Close filter, control unit and analyzer electronics covers completely after working on the device, otherwise ignitable sparks can escape and lead to explosions.

- ▶ Close filter, analyzer electronics and control unit covers completely after working on the device..
- ▶



DANGER: Danger of explosion through sparking

Damaged threads relevant for ignition protection can lead to explosion by sparking.

- ▶ Damaged threads relevant for ignition protection must be replaced. Repair is not permitted.



DANGER:

Risk for system safety through work on the device not described in these Operating Instructions

Work on the device not described in these Operating Instructions or associated documents can lead to unsafe operation of the measuring system and therefore endanger plant safety.

- ▶ Only carry out the work on the device described in these Operating Instructions and associated documents.



DANGER:

Danger of explosion through incorrect performance of work described in these Operating Instructions

Incorrect performance of work in potentially explosive atmospheres can cause serious injuries to people and damage during operation.

- ▶ Maintenance and commissioning tasks as well as checks should only be carried out by experienced/trained personnel with knowledge of the rules and regulations for potentially explosive atmospheres, especially:
 - Ignition protection types
 - Installation rules
 - Zone classification



DANGER:

Danger of explosion when opening the analyzer electronics cover (see [“Installing and insulating the analyzer unit”, page 37](#))

Opening the analyzer electronics cover during operation can lead to explosions.

- ▶ Only open the analyzer electronics cover in an Ex-free area.
- ▶ Only open the analyzer electronics cover when the stack is switched off.

Escaping gases



DANGER:

Risk of burns and poisoning from escaping hot and toxic gas in systems with overpressure conditions

In systems with overpressure, hot and toxic gas can escape from the process connection. This can lead to burns or damage to health.

- ▶ Always keep the process connection tightly closed.
- ▶ Pay attention to hot surfaces.
- ▶ Wear appropriate protective equipment.

Potential equalization



CAUTION:

Danger of explosion through incorrect or missing grounding

Incorrectly connected potential equalization can lead to potential differences which can create sparks due to transient phenomena (discharges) and lead to explosions in Ex-atmospheres.

- ▶ Connect a potential equalization on all planned points on the device components.
- ▶ Ensure the potential equalization is connected during all work on the device described in these Operating Instructions.
- ▶ Ensure there is a ground connection via the voltage supply.
- ▶ Perform regular checks of the grounding connections for intactness.

2.2 Warning information on device

Control unit Z200EXG-y1***** (y= 1, 2)

Fig. 1: Warning information on control unit

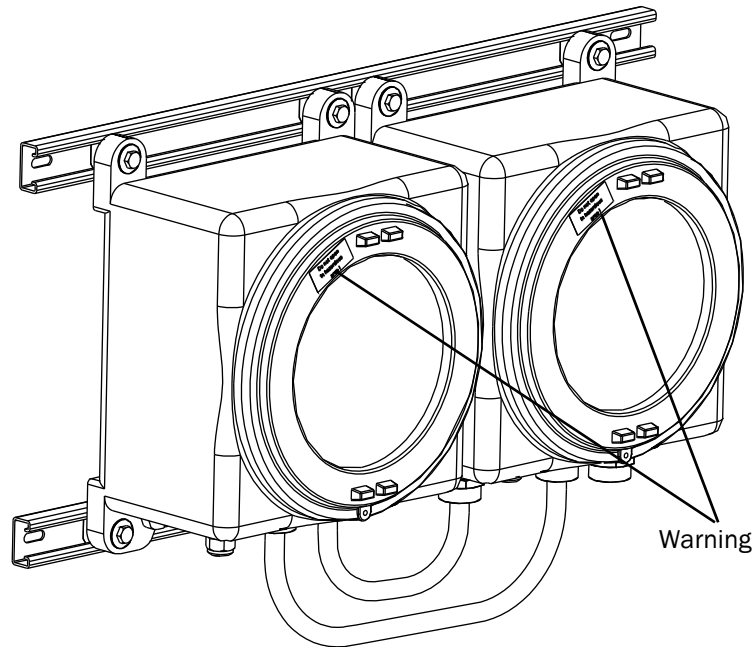

- Warning - Only open in an Ex-free environment.
- Warning - Do not open under voltage.

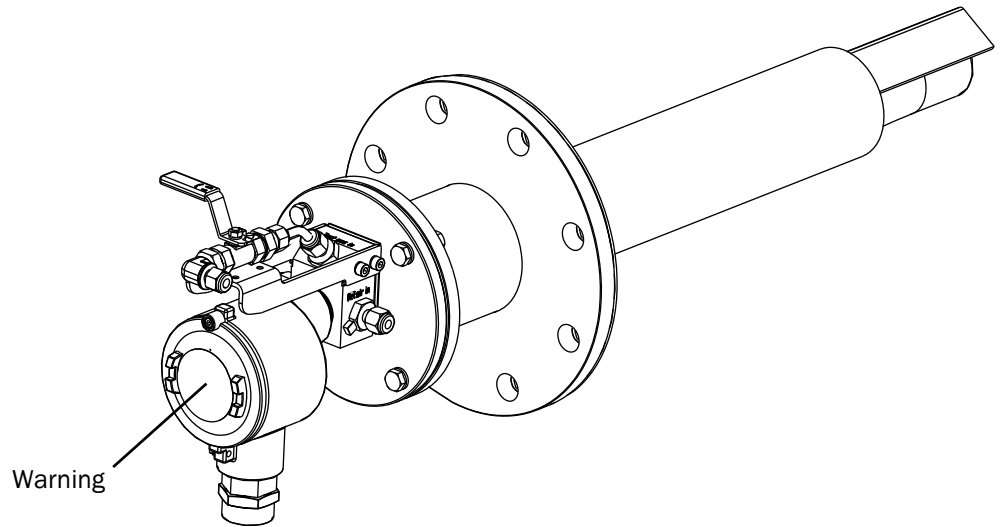
Analyzer unit Z200EXG-y2*** (y= 1, 2)**

- Warning - Do not open under voltage and when the incinerator is in operation.
- Warning – Observe the wait time for cooling down of all analyzer unit components to 200 °C (T3) (min. 1 hour)
- Warning - Follow the instructions in the Manual.
- Warning – Hot surfaces

Pneumatic unit Z200EXG-...

- Warning – In Ex-areas, only clean the surface with a damp cloth

Optional electric pneumatic valve

- Warning – Risk of electrostatic charge - see Instructions

2.3 Intended use**2.3.1 Purpose of the device**

The device is a stationary oxygen measuring device and serves continuous measurement of oxygen as emission and process monitoring in the industrial sector. The device measures continuously directly in the gas duct (in-situ).

2.3.2 Operation in potentially explosive atmospheres

ZIRKOR200 Ex-G is suitable for use in explosive gas atmospheres of gas groups IIA, IIB and IIC according to ATEX (EN60079-10) and according to IECEx (IEC60079-10) and corresponds to categories 2G and EPL Gb for use in Zone 1.

The control unit is classified in temperature class T6, the analyzer unit in temperature class T3.

Marking of device components

Control unit Z200EXG-y1***** (y= 1, 2)

- ATEX
⚠ II 2G Ex db IIC T6 Gb
- IECEX
Ex db IIC T6 Gb
- Special conditions:
Equipment used to the cable inlets and plugs for unused threads for cable inlets must be certified according to IEC 60079-0 and IEC 60079-1.

It is not permitted to repair flameproof joints in the enclosure.

Analyzer unit Z200EXG-y2***** (y= 1, 2)

- ATEX
⚠ II 2G Ex db IIC T3 Gb
- IECEX
Ex db IIC T3 Gb
- Special conditions for safe use:
 - The specification of temperature class T3 applies to an ambient temperature range of -20 °C to +55 °C.
 - The heater voltage of the measuring probe must be switched off by a monitoring device independent of the control and certified for this use when a limit temperature of 890 °C for an ambient temperature of up to 40 °C and a limit temperature of 845 °C for an ambient temperature of up to 55 °C is reached.
 - The warning to open the enclosure and the manufacturer's instructions must be strictly followed.
 - Only use the oxygen analyzer unit with associated protective pipe with flue gas feed in flue gases, when the composition is not critical concerning the corrosion effect on the materials used. If this cannot be ensured, regular recurring checks must be carried out at sufficiently short intervals.
 - The flue gas temperature must not exceed 500 °C on the measuring probe. Higher process temperatures are possible when a suitable flue gas line with flue gas cooling ensures that the flue gas does not exceed the limit value of 500 °C under all process conditions when it reaches the analyzer unit.

Pneumatic unit Z200EXG

- Special conditions for safe use:
 - In Ex-areas, only clean the surface with a damp cloth.

Optional electric pneumatic valve Z200EXG

- ATEX
⚠ II 2G Ex eb mb IIC T4 Gb
- IECEX
Ex eb mb IIC T4 Gb

Do not remove, add or modify any components to or on the device unless described and specified in the official manufacturer information. Otherwise the approval for the device for use in potentially explosive atmospheres becomes void.

Adhere to the prescribed maintenance intervals, see [“Maintenance plan”, page 72](#).

2.3.3 Restrictions of use

- The ZIRKOR200 Ex-G is certified for a process-side operating range of 800 mbar abs. to 1100 mbar abs. The use in different pressures is not conform to the EX-certification and therefore not allowed.
- Operate the ZIRKOR200 Ex-G within the described specifications (see [“Technical data”, page 96](#)). If the ZIRKOR200 Ex-G is operated outside the specifications, it does not conform to the Ex-certification and is therefore not allowed.

2.4 Responsibility of user

2.4.1 Designated users

see “User qualification”, page 8

The ZIRKOR200 Ex-G should only be installed and operated by skilled technicians who, based on their technical training and knowledge as well as knowledge of the relevant regulations, can assess the tasks given and recognize the hazards involved.

2.4.2 Correct project planning

This Manual presumes that the device has been delivered as specified during project planning (i.e., based on the SICK application questionnaire) and the relevant delivery state of the device (delivered System Documentation).

- ▶ If you are not sure whether the device complies with the planned configuration or the delivered system documentation:
Contact SICK Customer Service.

2.4.3 Correct use

- ▶ Only use the ZIRKOR200 Ex-G as described in these Operating Instructions (see “Intended use”, page 13). The manufacturer bears no responsibility for any other use.
- ▶ Carry out the prescribed maintenance work (see “Maintenance plan”, page 72).
- ▶ Do not carry out any work on the ZIRKOR200 Ex-G not described in these Operating Instructions.
Do not remove, add or modify any components to or on the ZIRKOR200 Ex-G unless described and specified in the official manufacturer information.
Otherwise:
 - Any warranty by the manufacturer becomes void.
 - The ZIRKOR200 Ex-G can become dangerous.
 - The approval for use in potentially explosive atmospheres is no longer valid.

2.4.4 Special local conditions

- ▶ Follow all local laws, regulations and company-internal operating directives applicable at the installation location.

2.4.5 Read the Operating Instructions

- ▶ Only put the ZIRKOR200 Ex-G into operation after reading and understanding the Operating Instructions.
- ▶ Observe all safety information.
- ▶ If anything is not clear: Contact SICK Customer Service.

These Operating Instructions must be:

- ▶ Available for reference.
- ▶ Passed on to new owners.

3 Product description

3.1 Product identification

Product name	ZIRKOR200 Ex-G GasEx Oxygen analyzer with analyzer unit and control unit
Manufacturer	SICK AG Erwin-Sick-Str. 1 · D-79183 Waldkirch · Germany
Type designation	Z200EXG-y0***** (y= 1, 2) for control unit and analyzer unit* Z200EXG-y1***** (y= 1, 2) for control unit Z200EXG-y2***** (y= 1, 2) for analyzer unit

*The system code of the complete system serves as additional information but has no reference for the approval.

3.2 Type plates

The type plate is located on the unit components as shown in the Figures below.

Fig. 2: Type plates (1)

Control unit Z200EXG-y1***** (y= 1, 2)

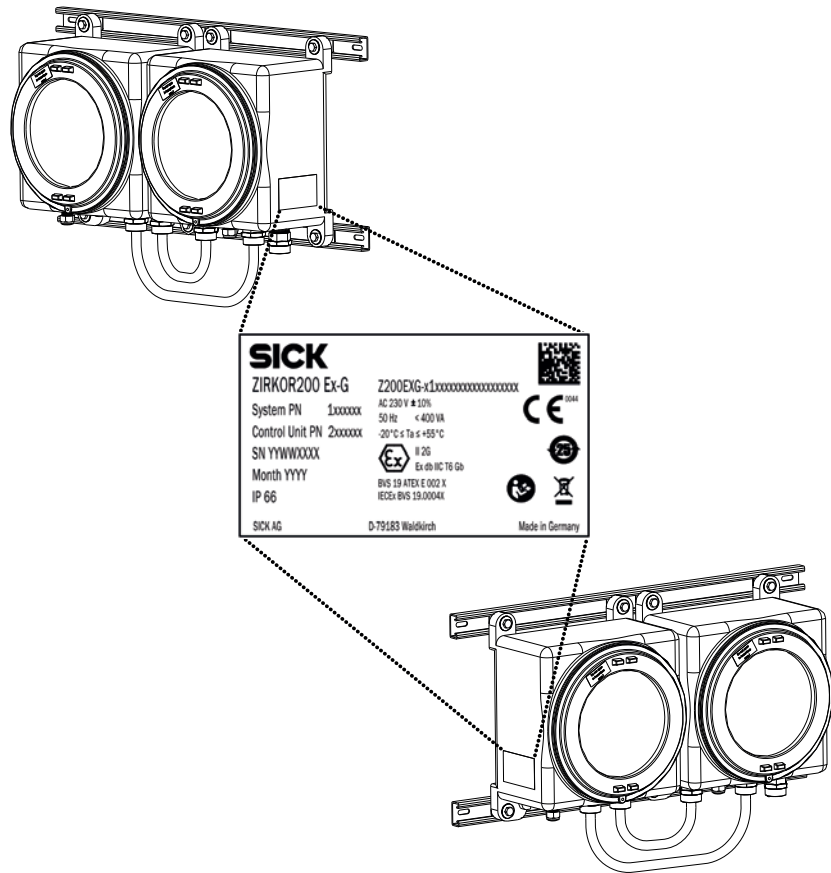

Analyzer unit Z200EXG-y2***** (y= 1, 2)

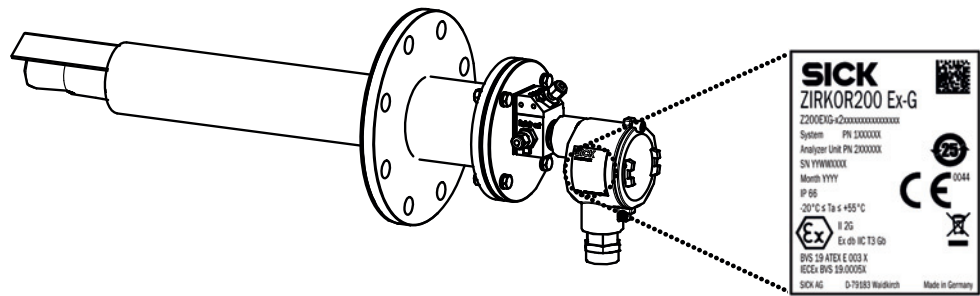

Type plate of the automatic pneumatic unit

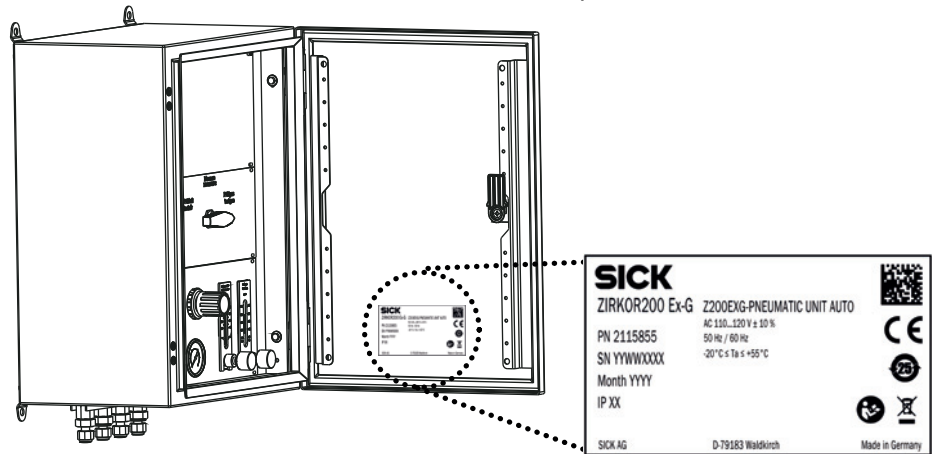

Type plate of the semi-automatic pneumatic unit
See type plate of automatic pneumatic unit

3.3 Device versions

Fig. 3: Type code for Ex-device versions

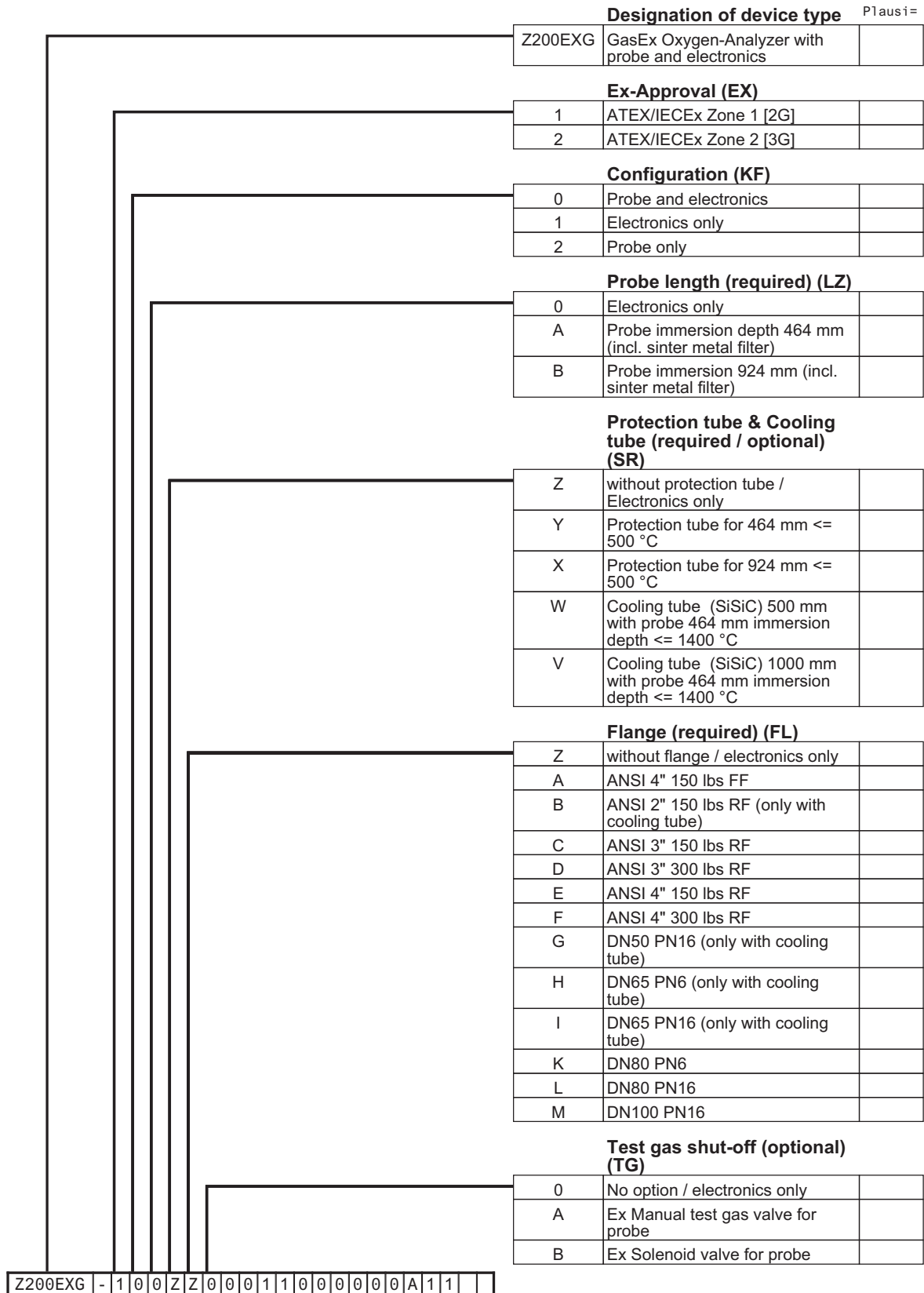

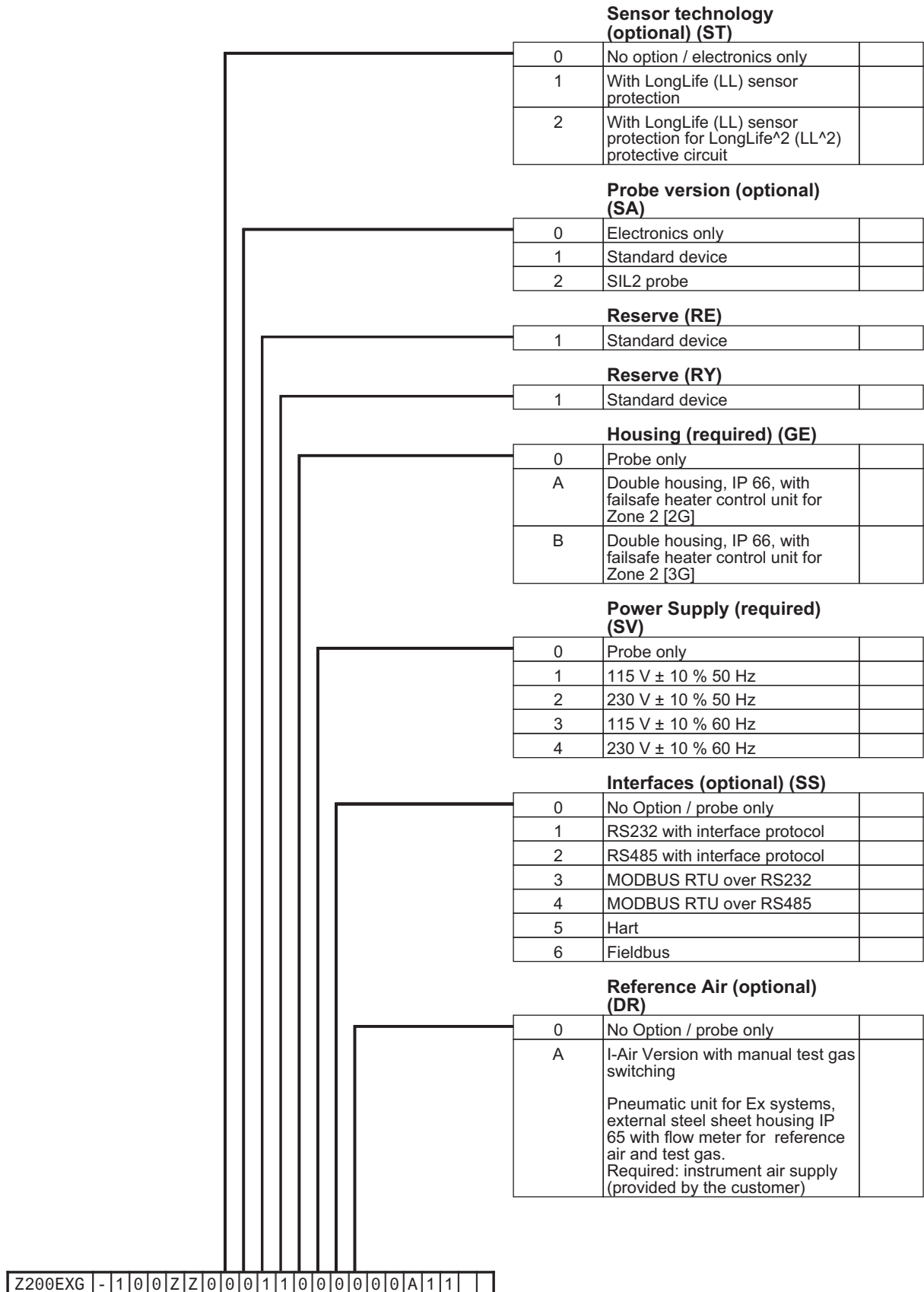

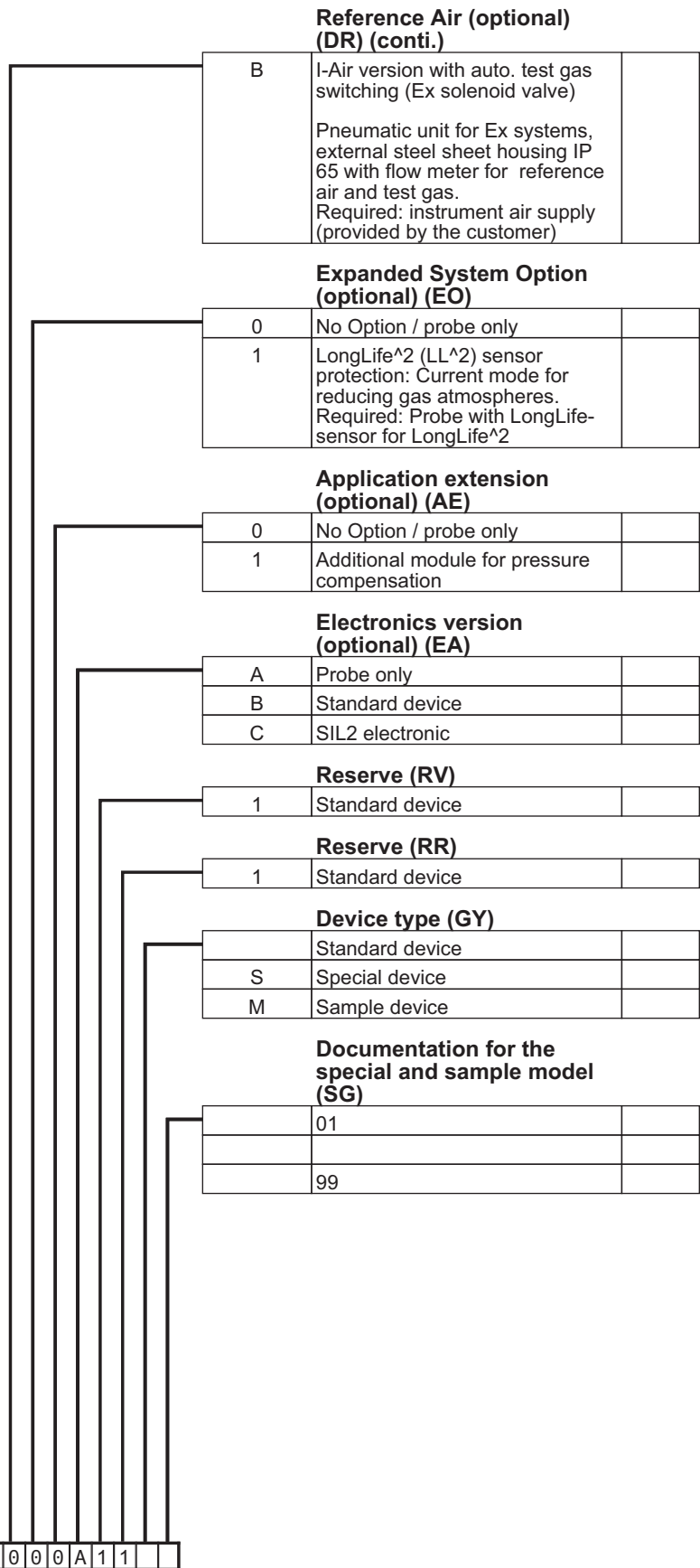

3.4 Device variants

- Analyzer unit, standard
- Analyzer unit, with cooling protection pipe

3.5 Options

- Analyzer unit: Manually operated valve for test gas feeding mounted in Ex-area
- Analyzer unit: Solenoid valve for test gas feeding mounted in Ex-area
- Pneumatic unit, manual, mounted in Ex-area
- Pneumatic unit, automatic, mounted in Ex-area
- Counter flange
- Various interfaces (RS-232, RS485, HART, Fieldbus)

3.6 Expansion modules

The electronics are also available optionally with different interfaces (RS-232, RS485, HART, Fieldbus). If you have ordered one of these options, a separate Manual/Specification for this interface is included with the delivery.

4 Layout and function

4.1 System overview

Fig. 4: ZIRKOR200 Ex-G version of analyzer unit for flue gases up to 500 °C

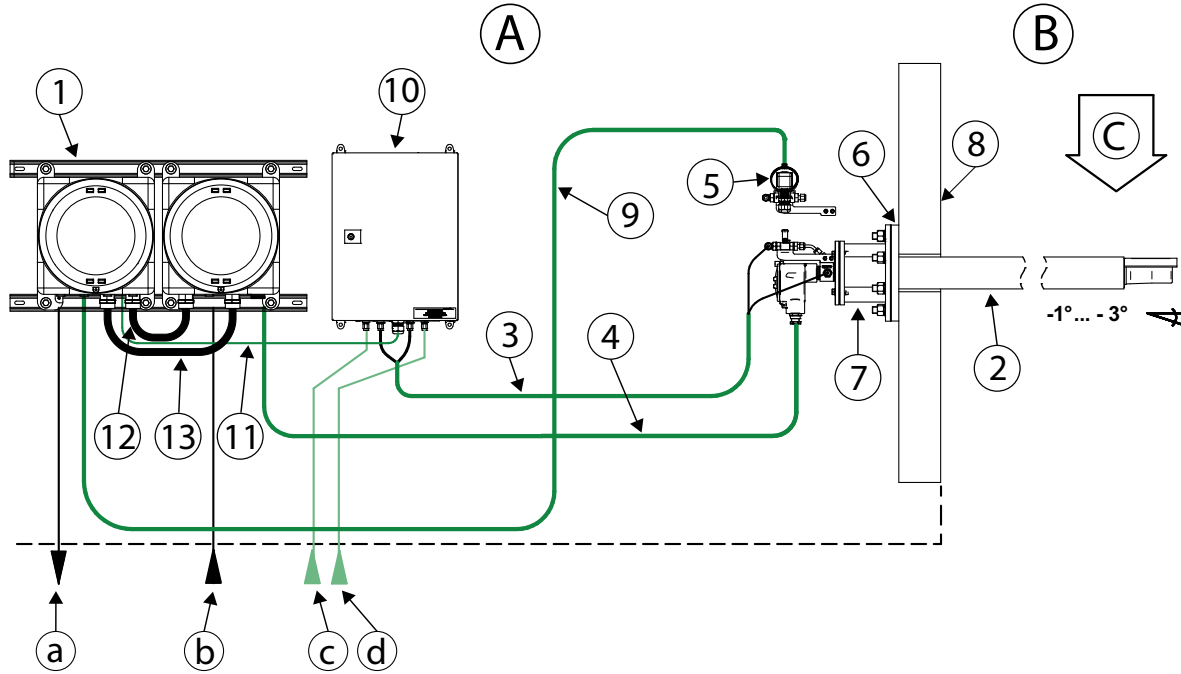

1 Control unit / IP66

2 In-situ measuring probe / IP66

3 Pneumatic line

4 O₂ connection cable, analyzer electronics - control unit

5 Solenoid valve (optional)

6 Counter flange (optional)

7 Insulation: Customer*

8 Duct wall

9 Solenoid valve control cable (only with solenoid valve option)

10 Pneumatic unit IP 66

11 Connection cable, pneumatic unit - control unit (only with solenoid valve option)

12 Connection cable

13 Connection cable

A Potentially explosive atmosphere Zone 1 2G IIC T6

Ambient temperatures: -20 °C to +55 °C (-4 °F to +131 °F)

B Potentially explosive atmosphere Zone 1 2G IIC T3

Flue gas duct / combustion chamber - flue gas temperature up to 500 °C

C Flue gas direction

a Output signals (analog and digital)

b Power supply, power voltage 230 V/115 V ±10% 50 to 60 Hz, max. 400 VA

c Test gas inlet

d Instrument air inlet

* Note: Risk of corrosion due to lack of insulation

4.2 Measuring principle

The ZIRKOR200 Ex-G oxygen measuring system consists of an in-situ analyzer unit, which is installed on the duct with the gas to be analyzed, and a control unit for voltage and gas supply as well as for signal processing. An oxygen sensor regulated to 800 °C which functions according to the zirconium oxide principle is fitted on the probe tip. An mV signal is measured between the reference gas side of the sensor (inside, instrument air 20.95% O₂) and the measuring gas side, which depends logarithmically on the relation of the oxygen partial pressures of both sides. The mV signal is converted to the oxygen partial pressure in the sample gas using the Nernst equation, which determines the O₂ concentration in the sample gas.

4.3 Scope of application

The ZIRKOR200 Ex-G GasEx oxygen measuring system is suitable for measuring oxygen (O₂) in flue gases and other non-combustible gases.



NOTICE:

The system must not be used to determine the oxygen content of combustible gases because the measuring accuracy cannot be guaranteed when combustible gases occur.



NOTICE:

Device damage with regular O₂ concentrations below 0.5%. Under normal process conditions, the minimum concentration of O₂ in the flue gas should not be less than 0.5%.

- ▶ The cell protection circuit option is recommended when the O₂ concentration regularly falls below 0.5%. Called LL² (LongLife²), so that the O₂ sensor is permanently protected.
-

4.4 Potential hazards



WARNING: Danger of burns on hot components which are in the process gas

The temperature of the probe filter head and all parts in the process gas is 150 °C to 800 °C (302 °F to 1472 °F) during operation. Directly touching the parts for disassembly or maintenance causes serious burns.

- ▶ Use heat protection gloves when removing the measuring probe.
 - ▶ Switch the electronics supply voltage off before removing the measuring probe.
 - ▶ Place the analyzer unit in a safe, protected area after removal and wait until the measuring probe temperature has cooled down to the ambient temperature.
-

4.5 Process interruption

The oxygen measuring system must remain in operation even when the process is interrupted or the system is temporarily switched off (e.g. at night or on weekends). Frequent cooling and heating of the analyzer unit leads to a thermal load on hot analyzer unit components (heater, thermoelement and O₂ sensor) and shortens their service life. SICK shall not be liable for any resulting damage.

4.6 Pneumatic unit

The pneumatic unit is used to supply reference air and for the test gas feed of the analyzer unit. The pneumatic unit is controlled fully automatically or manually with a ball valve provided by the operator.

The pneumatic unit in a separate field housing can be installed next to the control unit. The pneumatic unit is available in two versions:

- Semi-automatic adjustment
- Fully automatic adjustment

With fully automatic adjustment, a solenoid valve in the pneumatic unit automatically switches between test air and test gas.

With semi-automatic adjustment, the switchover between test air and test gas is performed by means of a ball valve.

4.7 Explosion protection description - ignition protection types

The ZIRKOR200 Ex-G system is certified for use in Ex-areas of zone 1, gas group IIC. The control unit Z200EXG-y1 (control unit as part of the complete Z200EXG-y0 system) is classified in temperature class T6, the analyzer unit Z200EXG-y2 (analyzer unit as part of the complete Z200EXG-y0 system) in T3.

Ignition protection is implemented in the analyzer unit in combination of ignition protection type flameproof enclosure Ex “d” for analyzer unit and control unit and ignition source monitoring (see the following notes).



Note:

To ensure the maximum permissible surface temperature, the analyzer unit is switched off at 810 °C when the operating temperature is overflowed and can only be heated up by a restart. The recording of the operating temperature is done redundantly with 2 thermocouples in a sheathed thermoelement.

Switching off is performed by a protective device independent of the controller and SIL certified for this purpose. **Operating temperature of the analyzer unit is 800 °C.**

4.7.1 Ignition protection type “flameproof enclosure” Ex “d”

For the analyzer unit and the control unit, the connection terminals for connection to the supply voltage, supply circuits for heating and solenoid valves as well as all signal circuits in rooms are fitted in ignition protection type “Flameproof enclosure” Ex “d”. The sensor, which is temperature-stabilized at 800 °C, is also located inside the “flameproof enclosure” and thus does not represent an ignition source for the environment.

With ignition protection type “flameproof enclosure” Ex “d”, the function is based on the containment of a possible explosion inside the enclosure. This is achieved by an explosion pressure-resistant design of the enclosure together with flameproof joints on all enclosure openings, e.g. enclosure covers and cable inlets. Furthermore, the surface temperature is limited below the ignition temperature of the surrounding explosive atmosphere even if an expected fault occurs.

The threaded joints between the enclosure and cover as well as on the threaded connections are flameproof joints.

Flameproof joints must not be repaired.

The connecting surfaces must not be painted or powder coated.

It must be ensured that no explosive atmosphere is present before opening and when the cover of an “Ex-d” area is open (e.g. during connecting or service work).

Seal all unused enclosure openings with the appropriate dummy screw fittings.

Control unit Z200EXG-y1*** (y= 1, 2)**

The control unit consists of two flameproof enclosures electrically connected to each other via two cables.

Fig. 6: Control unit

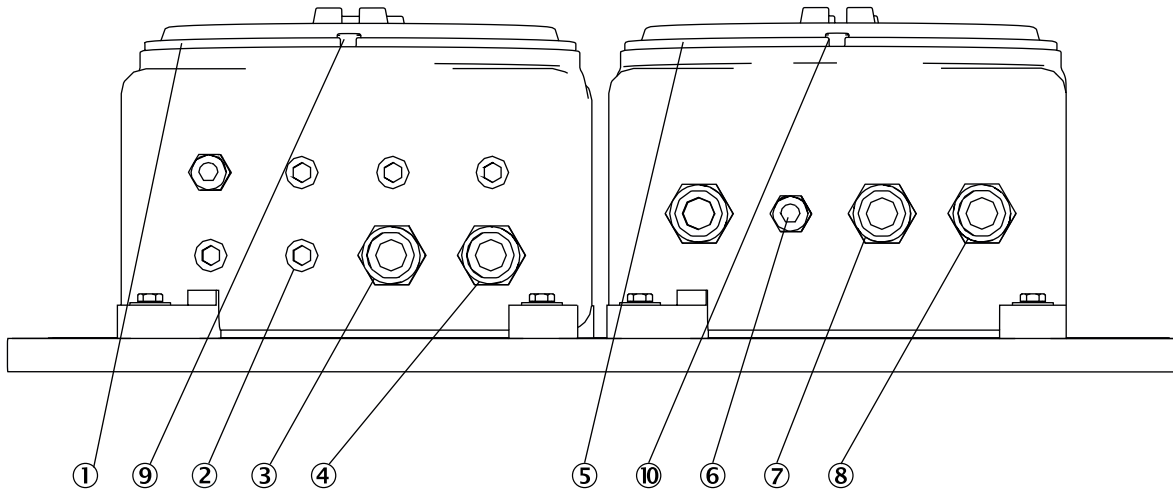

No.	Component	Gap description
1	Enclosure 1 - cover 1	Thread gap M250x3
2	Enclosure 1 - screw fitting/plug 1/2"	1/2" NPT thread - 6 pcs
3	Enclosure 1 - screw fitting/plug 3/4"	3/4" NPT thread - 1 pc
4	Enclosure 1 - screw fitting/plug 3/4"	1" NPT thread - 1 pc
5	Enclosure 2 - cover 2	Thread gap M250x3
6	Enclosure 2 - screw fitting/plug 1/2"	1/2" NPT thread - 1 pc
7	Enclosure 2 - screw fitting/plug 3/4"	3/4" NPT thread - 1 pc
8	Enclosure 2 - screw fitting/plug 1"	1" NPT thread - 2 pcs
9	Locking screw, enclosure cover 1	-
10	Locking screw, enclosure cover 2	-

The enclosures are provided with various NPT threads for connection of a certified "Conduit" system or for fitting a cable inlet certified according to IEC60079-1 "Ex-d". Cable and cable inlets of simple design must not be used. Observe the relevant Sections of IEC60079-1. When connecting to a "conduit" system, the associated sealing device must be located directly on the "Ex-d" terminal compartment.

The screw plugs (protective caps) fitted at the factory, depending on the type ordered, are part of the "Ex-d" enclosure. When a screw plug different from the one fitted at the factory is used, use a suitable screw plug certified according to IEC60079-1.

Openings not used must be closed off according to IEC 60079-1.

The covers of the "Ex-d" terminal compartments must be screwed in to the stop before commissioning. It must be secured by screwing in the cover locking screw to the stop.

Analyzer unit Z200EXG-y2***** (y= 1, 2)

Fig. 7: Analyzer unit

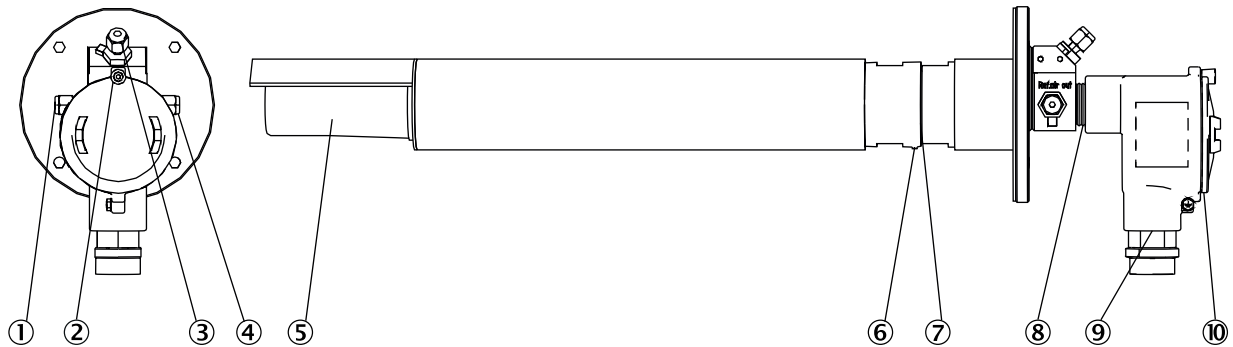

No.	Component	Gap description
1	Breathing device - reference air outlet	Sintered metal
2	Locking screw, enclosure cover	-
3	Breathing device - test gas inlet	Sintered metal
4	Breathing device - reference air outlet	Sintered metal
5	Filter head on the measuring probe	Sintered metal
6	Measuring probe locking screw	-
7	Measuring probe with filter head	Thread gap M56x2
8	Enclosure - measuring probe	Taper thread, thread gap 1" NPT thread
9	Enclosure - screw fitting	1" NPT thread
10	Enclosure - cover	Thread gap M80x2

The "Ex-d" terminal compartment of the analyzer unit is equipped with a 1" NPT thread for connection to a certified "Conduit" system or for fitting an Ex-d cable inlet according to IEC60079-1. Cable inlets of simple design must not be used. Observe Sections 13.1 and 13.2 of IEC60079-1. When connecting to a "conduit" system, the associated sealing device must be located directly on the "Ex-d" terminal compartment.

The cover of the "Ex-d" terminal compartment must be screwed in to the stop before commissioning. It must be secured by screwing in the cover locking screw until it stops.

Cable inlets

A variety of certified "Ex-d" cable inlets are delivered from the factory. Depending on the type ordered, they are suitable as inlets for armored or unarmored cable types. Observe the delivered document on the relevant cable inlet.

Tightly screw the "Ex-d" cable inlets into the enclosure. The delivered cable inlets are suitable for the enclosure temperature range stated in the ZIRKOR200 Ex-G certification.

If other cable inlets than those delivered are used, they must have an Ex-qualification (ignition protection) and the IP classification and the temperature stability (COT) must be adhered to, according to the application conditions.

The connection cables, cable inlets and screw plugs or pipe sealing devices must be suitable for the lowest ambient temperature.

Observe the following points during installation of the cable inlets:

- Only use cable inlets certified for the application.
- Only use cable inlets with sufficient temperature range for the application.
- Ensure that the degree of protection is not affected by the cable inlets or the sealing plugs.

Cables

Use cables with a temperature stability of minimum 92 °C for ambient temperatures of >60 °C.

The connection cable to the Ex-d terminal compartment must be laid firmly and in such a way that it is adequately protected against damage. Lay the connection cable according to IEC 60079-14.

The connection cables, cable inlets and screw plugs or pipe sealing devices must be suitable for the lowest ambient temperature.

4.7.2 Ignition source monitoring of the analyzer unit by means of temperature monitoring

The temperature of the analyzer unit is monitored by an additional electronic system (Part No. 2105158) with two thermoelements. The electronics are designed to be fail-safe (redundant). These automatically switch off the analyzer unit heating when the operating temperature of the analyzer unit is exceeded. The switch-off temperature is 810 °C. In addition, the heating is switched off in the event of a fault in one of the thermoelements. The electronics go into self-holding mode, which means that if a fault occurs, the electronics must be reset. The printed circuit board must be checked every three years by the manufacturer for safe operation. The next test date is on the sticker on the printed circuit board.

Fig. 8: Sticker with test date

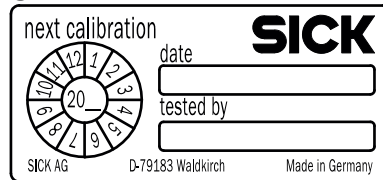

4.7.3 Ignition protection types on solenoid valves

Solenoid valve of the analyzer unit / pneumatic unit valve

ATEX

II 2G Ex eb mb IIC T4 Gb

IECEX

Ex eb mb IIC T4 Gb

5 Installation

5.1 Determination of the requirements for explosion protection

Check with the marking of the device and its components whether all requirements regarding zone classification, temperature class, gas group, safety level, ambient temperatures and pressure conditions are met.

5.2 Information on installation in potentially explosive atmospheres

Correct installation



DANGER: Danger of explosion during installation work

There is a danger of explosion due to sparking during installation, for example when cables are connected or components are dropped.

- ▶ Perform installation work only in the Ex-free area.



DANGER: Danger of explosion through incorrect installation work

Incorrect assessment of the installation location as well as all further installation work in potentially explosive atmospheres can cause serious injuries to people and damage during operation.

- ▶ Installation, commissioning, maintenance and testing may be performed only by experienced persons who have knowledge of the rules and regulations for potentially explosive atmospheres, particularly:
 - Ignition protection types
 - Installation rules
 - Zone classification
- ▶ Standards to be applied
- ▶ Local work safety regulations



DANGER: Danger of explosion due to damaged probe tube

A cold analyzer unit can be damaged by condensed, corrosive flue gas, as a result of which the analyzer unit is no longer encapsulated in a flameproof enclosure and can lead to explosions.

- ▶ The analyzer unit must be in operation while in the process.



CAUTION: Risk of injury when the device drops down

The device is heavy and may cause injury if dropped.

- ▶ Carry out assembly work on the device in pairs.



WARNING: Risk of damage to flameproof joints

- ▶ Do not damage the surfaces of the flameproof joints between enclosure and enclosure cover of control unit and analyzer unit while opening or closing the devices.
- ▶ When a surface of a flameproof joint is damaged, replace the enclosure and the enclosure cover.
- ▶ Prior to fitting the enclosure cover on the enclosure, protect the surfaces of the flameproof joint with a thin layer of a suitable protective grease.



NOTICE: Protect the device from atmospheric conditions

When using outdoors under weather conditions, equip the explosion-proof electrical equipment with a protective roof or wall.



NOTICE: Pay attention to the distance between flameproof joint and obstacles

If there are other fixed obstacles outside the enclosure, the minimum distance between the flameproof joint of the enclosure and these obstacles shall not be less than the distance specified in IEC/EN 60079-14.

- Gas group IIA: 10 mm
- Gas group IIB: 30 mm
- Gas group IIB+H2 or IIC: 40 mm



DANGER: Danger from unallowed cable inlets

Explosion protection endangered.

- ▶ Only use cable inlets approved for the required ignition protection type.
 - ▶ Take the thread type and size into account when selecting or replacing cable inlets, see [“Connecting the control unit”, page 45.](#)
-



DANGER: Danger through open drill holes or unused cable inlets

Explosion protection endangered.

- ▶ Always close off unused cable inlets with the approved sealing plugs.
 - ▶ Take the thread type and size into account when selecting or replacing suitable plugs, see [“Connecting the control unit”, page 45.](#)
-



WARNING: Danger due to heavy weight

Risk of injury and risk of property damage.

- ▶ Use suitable lifting equipment.
 - ▶ Secure against tilting.
-

5.3 Tools required

Tools required	Required for
Allen key set	Securing the enclosure cover
Slotted screwdriver set	Unlocking the connection terminals
Cross-head screwdriver set	Opening the analyzer electronics cover as well as apertures
Ferrule pliers	Cable preparation
Wire stripper	Cable preparation

5.4 Material required

Material required	Required for
Ferrules	Cable preparation

5.5 Preparing the measuring point



NOTICE:

Basis for determining the measuring point:

- Preceding project planning (e.g., based on the SICK application questionnaire)
 - Regulations of local authorities
- Responsibility of the plant operator
- Determining the measuring point
 - Preparing the measuring point

5.6 Transport



DANGER: Danger of explosion through electrostatic charges

There is a danger of explosion due to sparks caused by electrostatic charge, for example during transport or when unpacking the analyzer unit and control unit.

- ▶ Only transport and unpack in an Ex-free area.



NOTICE:

The device may only be transported and installed by skilled persons who, based on their training and knowledge as well as knowledge of the relevant regulations, can assess the tasks given and recognize the dangers involved.

The device must be lifted and transported by at least two persons.

5.7 Storage information

SICK devices and spare parts must be stored in a dry place with sufficient ventilation. Paint fumes, silicone sprays etc. must be avoided in the storage environment.



DANGER: Health hazard due to contaminated measuring probe

Depending on the composition of the gas in the measuring channel, the analyzer unit, after use in the process, may be contaminated with substances that can cause serious damage to health.

- ▶ Decontaminate the analyzer unit before storage.
- ▶ Wear the specified protective clothing for all work with a contaminated analyzer unit.
- ▶ Clean all components of the measuring system with slightly moistened cleaning cloths. Use a mild cleaning agent here.
- ▶ Pack all components for storage or transport. Preferably use the original packing.
- ▶ Store all components of the measuring system in a dry, clean room.
Storage temperature for all components -40 °C to +80 °C.

5.8 Scope of delivery

Check the scope of delivery according to the order confirmation/delivery note.

Checking the delivery state

Check all components have no exterior damage.

Make sure the supply voltages indicated on the type plates correspond to the system conditions.

5.9 Installation

Installation steps overview

Step	Procedure	Reference
1	Fit the counter flange on the duct.	see "Fitting the counter flange on the duct", page 35
2	Fit the control unit.	see "If necessary, attach duct insulation to protect the device from heat.", page 35
3	Install the control unit.	see "Installing the control unit", page 35
4	Fit the analyzer unit.	see "Fitting the analyzer unit", page 36
5	Fit the analyzer unit with cooling protection pipe.	see "Fitting the analyzer unit with cooling protection pipe", page 38
6	Install the analyzer unit.	see "Installing the analyzer unit", page 38
7	Align the V-shield.	see "Aligning the V-shield", page 39
8	Lay connection cable.	see "Laying the connection cable", page 40
9	Install connection cable.	see "Installing connection cables", page 41
10	Fit the pneumatic unit.	see "Fitting the pneumatic unit", page 42

5.9.1 Fitting the counter flange on the duct



DANGER: Hazard through hot, explosive or toxic flue gases

Hot and/or noxious gases can escape during assembly work on the gas duct depending on plant conditions.

- ▶ Work on the gas duct may only be performed by skilled persons who, based on their technical training and knowledge as well as knowledge of the relevant regulations, can assess the tasks given and recognize the hazards involved.
- ▶ Switch the plant off when working on the gas duct.

- ▶ On the basis of a risk assessment, the operator determines the required safety measures that must be observed when working with the system switched on.



NOTICE: Device damage due to faulty/missing insulation when the measuring duct is hot

- ▶ When the measuring duct is hot, design the insulation of the duct and the flanges so that the radiant heat of the duct is not higher than the permissible maximum temperature of the analyzer specification (see Technical Data).



Note:

The analyzer unit must not collide with other devices or installations.

- 1 Tilt the flange with pipe slightly downwards ($1^\circ - 3^\circ$) and allow it to protrude approx. 30 mm into the duct so that any condensate can drain off.
- 2 Now fix the flange with tube properly to the gas duct. Make sure the flange alignment does not change.
- 3 If necessary, attach duct insulation to protect the device from heat.

5.9.2 Installing the control unit

The lengths of the cables to the analyzer unit match the project planning.

- ▶ Fit the control unit on the 4 fixing points according to the project planning.

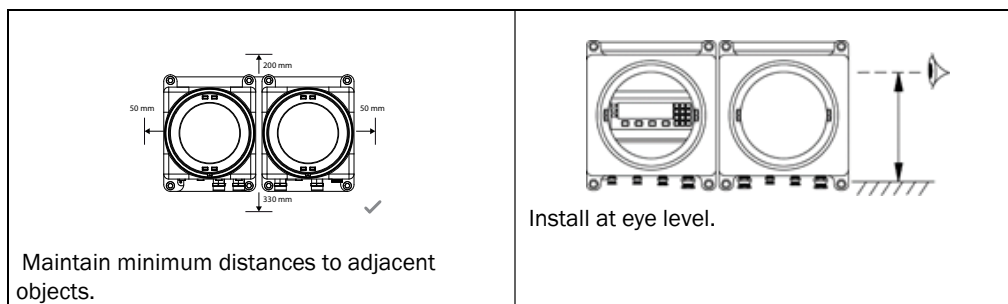

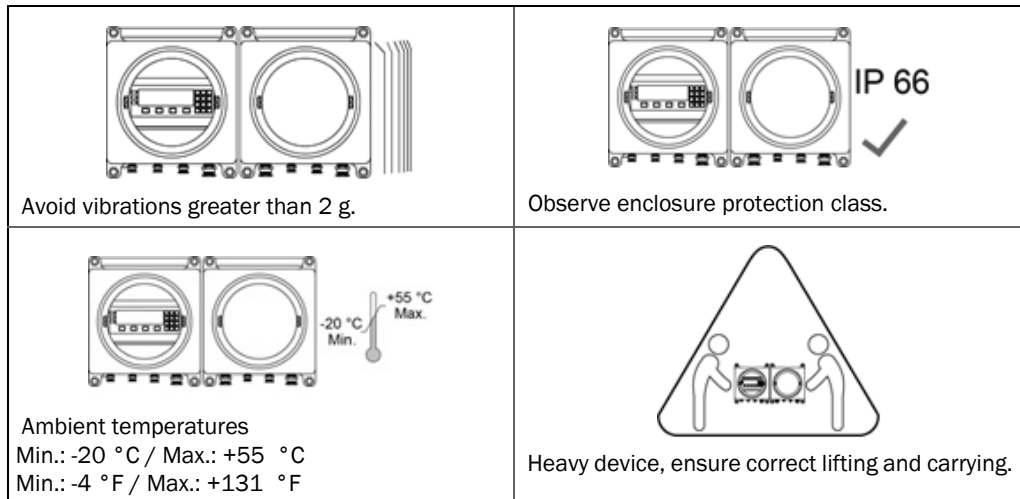
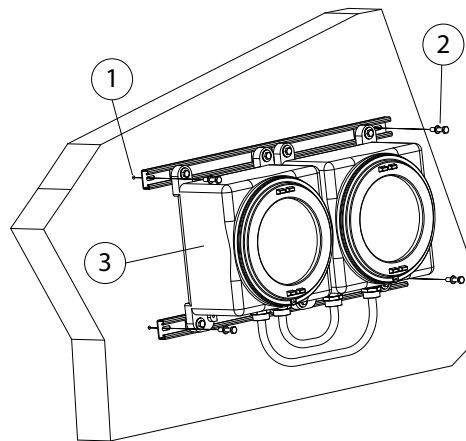

Fig. 9: Fitting the control unit



Secure the enclosure on a structure that can safely carry the weight of the enclosure. Use expansion anchors when fitting the enclosure on concrete. Use vibration resistant fitting material when fitting the enclosure in a steel frame. Protect the device from long or strong mechanical vibrations.

- 1 Drill holes according to the mounting method for safe installation.
- 2 Use screws suitable for the substrate and fastening method.
- 3 Control unit

5.9.3 Fitting the analyzer unit

- ▶ Push the analyzer unit into the duct.
- ▶ Align V-shield to flow, see [“Installing and insulating the analyzer unit”](#), page 37.
- ▶ Fix the analyzer unit to the duct.

Fig. 10: Installing and insulating the analyzer unit

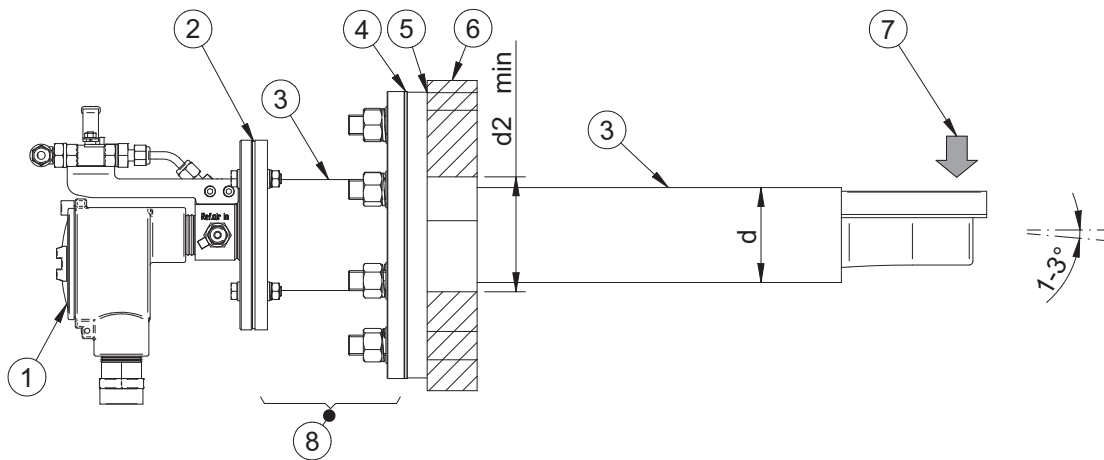

- 1 Analyzer electronics
- 2 Analyzer unit flange seal
- 3 Protective pipe
- 4 Protective pipe flange seal
- 5 Counter flange, welded on gas-tight
- 6 Process wall
- 7 Flue gas direction

5.9.4 Fitting the analyzer unit with cooling protection pipe



Note:

When using a cooling protection pipe, the part of the protection pipe protruding from the duct wall must be insulated or, if necessary, heated in order to prevent it from falling below the dew point, which can lead to corrosion.

Make sure the gas outlet is not blocked.

Fig. 11: Fitting and insulating the analyzer unit with cooling protection pipe

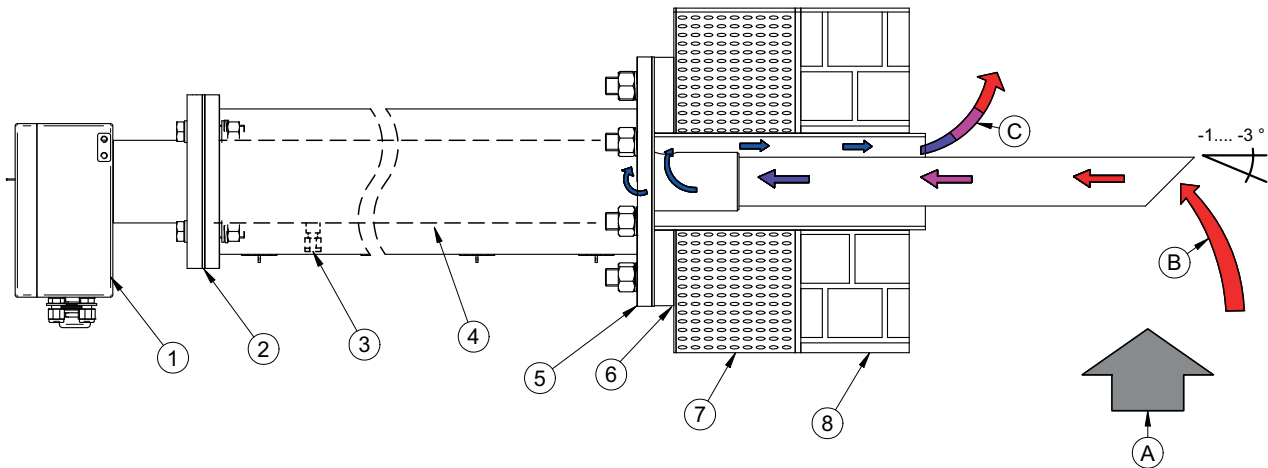



- 1 Analyzer electronics
- 2 Analyzer unit flange seal
- 3 Suction connection
- 4 Cooling protection pipe- insulate to prevent condensation
- 5 Protective pipe flange
- 6 Counter flange gas-tight and welded on at correct angle
- 7 Sheet steel
- 8 Duct wall
- A Flue gas
- B Gas inlet
- C Gas outlet - do not block

5.9.5 Installing the analyzer unit

Flue gas temperature, pressure and all other process conditions must be within the specification limits of the ZIRKOR200 Ex-G. Ensure sufficient clearance for fitting the measuring probe and protective pipe. Ensure access to the analyzer unit and the connection unit. Before breaking through the flue gas duct wall, make sure there is enough space inside and outside the duct for installation, that there are no fixtures in the vicinity and no other obstacles in the way.

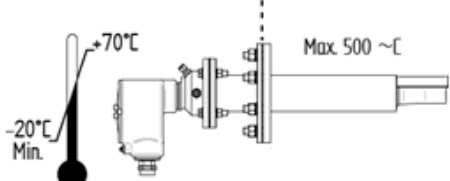
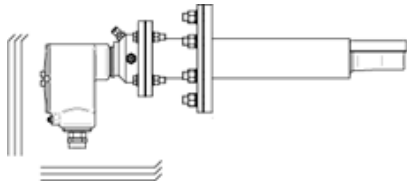
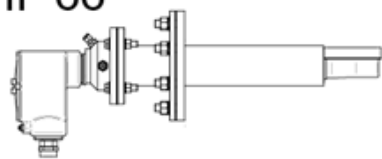
SICK recommends fitting the analyzer unit horizontally (-1 ° bis -3 °) to ensure the fastest possible response time.

 <p>Observe ambient temperature on the connection unit and process temperature.</p>	 <p>Avoid vibrations greater than 2 g.</p>
<p>IP 66</p>  <p>Observe protection class.</p>	 <p>Heavy device, ensure correct lifting and carrying.</p>

5.9.6 Aligning the V-shield

Before fitting the analyzer unit, determine flow direction (1) of the flue gas and turn V-shield (2) of the filter head against the exhaust gas flow. Filter head (3) is freely rotatable by 360° on a thread. To do this, completely loosen hexagon socket screws (4) on the filter head, align the filter head with V-shield with the help of jaw wrench (5) and tighten the hexagon socket screws again.



WARNING: Danger of explosion through breaching the flameproof enclosure

An Allen screw, damaged due to incomplete loosening or during filter replacement or a loose Allen screw can damage the flameproof enclosure by damaging the flameproof joint and thus lead to an explosion.

- ▶ Loosen and tighten the hexagon socket screw completely.
- ▶ Replace damaged hexagon socket screws.



WARNING: Danger of explosion due to loose filter head

Ensure that the filter head is completely screwed on to the thread (to the stop). From this end position, the filter head may be turned back once by max. 360° to align the filter head.

Explosion protection can no longer be guaranteed when the filter head is unscrewed further than 360°.

Fig. 12: Aligning the V-shield

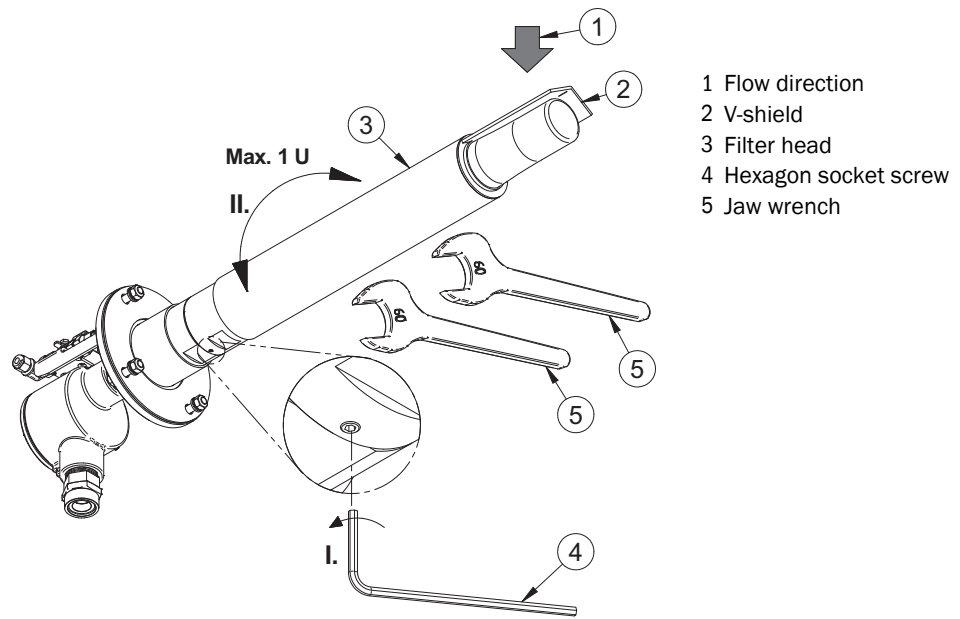

- 1 Flow direction
- 2 V-shield
- 3 Filter head
- 4 Hexagon socket screw
- 5 Jaw wrench

5.9.7 Laying the connection cable

- ▶ Lay cables – ensure no electrostatic charge is generated.
- ▶ Connect to analyzer electronics.



WARNING: Danger of explosion through electrostatic charges

Static charges on the cables can cause an explosion.

- ▶ Protect cables against electrostatic charges.
- ▶ Lay cables in the Ex-area firmly, for example by using cable trays.

- ▶ Connect control unit.



NOTICE:

- The system is not equipped with a power switch. A disconnecting device (e.g. a circuit breaker) must be installed in the power supply cable. The disconnecting device must comply with local safety standards, be easily accessible, located in the immediate vicinity of the system and clearly marked as the disconnecting device of the system (on/off switch).
- All other cables must be suitable for the ambient temperature onsite and must have the relevant cross-section.
- The connection terminals of the control unit are suitable for conductor cross-sections from 0.08 mm² (AWG 28) to 2.5 mm² (AWG 12). Reduce the suitable cross-sections by one size unit when using ferrules.



WARNING: Danger of explosion

- Disconnect the system from the power supply before opening the control unit or the analyzer electronics. Wait at least 5 seconds before opening.
- Prior to opening the control unit or the analyzer electronics, unlock the cover with the threaded pin and locked again after closing.
- After working on or replacing the Exd screw fittings or the Exd cables, ensure that they are screwed in completely and sealed off according to the Instructions. This is required to reach a type compliant state. Do not connect the power supply before all enclosures are securely closed, unless it is guaranteed that the environment is not explosive.

5.9.8 Installing connection cables



Note:

Connect the connection cable shielding to one side of the protective conductor (PE terminal) in the control unit. Do not connect the connection cable shielding to the analyzer unit as this will falsify the measured value.

The connection cable is suitable for an ambient temperature of -40 °C to +90 °C. Only lay the connection cable in a temperature range of -5 °C to +50 °C.

<p>Observe maximum possible signal cable length.</p>	
<p>Observe minimum bending radius.</p> <p>$R_{min} = 330 \text{ mm}$</p>	<p>Lay connection cable (1) only crosswise to cables (2) carrying the load current.</p>
<p>Ambient temperature limits - Installation</p>	<p>Ambient temperature limits - Operation</p>

Fig. 13: Connection cable

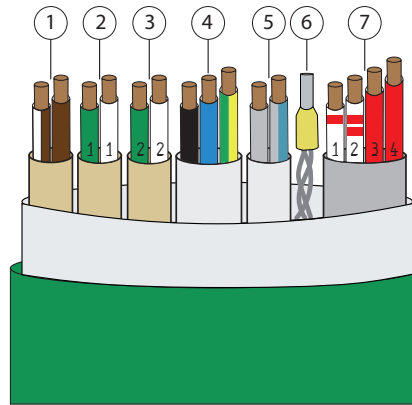

Probe cable				
No.	Function	Diameter	Colors	Additional information
1	Measuring cell	2 x 0.75 mm ²	White-brown / brown	With shielding
2	Thermoelement	2 x 0.75 mm ²	Green / white	With shielding
3	Thermoelement	2 x 0.75 mm ²	Green / white	With shielding
4	Measuring probe heater	3 x 1.5 mm ²	Black / blue / yellow-green	
5	Solenoid valve of the analyzer unit	2 x 0.75 mm ²	Grey / grey-blue	Without function for ZIRKOR200 Ex-G
6	Shielding			
7	Not used			

5.9.9 Fitting the pneumatic unit

- ▶ Mount on the wall.
- ▶ Make the pneumatic connections.
- ▶ Connect connection cable for solenoid valve (observe the manufacturer's Instructions).
- ▶ Connect grounding from the outside via a PE connection (M8x15).
- ▶ Firmly install the cable between pneumatic unit and control unit.

5.10 Electrical installation

Electrical safety



WARNING:

Endangerment of electrical safety during installation and maintenance work when the voltage supply is not switched off

- ▶ Before starting work on the device, ensure the voltage supply can be switched off according to the valid standards using a power isolating switch/circuit breaker.
- ▶ Make sure the isolating switch is easily accessible, located near the system and clearly marked (on/off switch).
- ▶ An additional disconnecting device is mandatory when the power isolating switch cannot be accessed or only with difficulty after installation of the device connection.
- ▶ After completion of the work or for test purposes, the voltage supply may only be activated again by authorized personnel complying with the safety regulations.



WARNING:

Endangerment of electrical safety through power cable with incorrect rating

Electrical accidents can occur when the power cable specifications have not been adequately observed.

- ▶ Always observe the exact specifications in the Operating Instructions (Technical data Section) when replacing a removable power cable.



WARNING:

Danger of electrical accidents

Incorrect performance of electrical work could result in serious electrical accidents.

- ▶ Electrical work on the device may only be carried out by electricians familiar with the possible dangers.



NOTICE:

Device damage through short-circuit on the device

The internal electronics can be damaged when signal connections are established and the voltage supply is switched on.

- ▶ Only carry out work on the device when the voltage supply is switched off.

Special safety instructions



DANGER:

Danger of explosion and expiration of the Ex-approval for the device when using cable inlets and closures not approved for operation in explosive environments

The cable inlets and closures are part of the explosion protection and must meet the requirements of the relevant standards for explosion protection.

- ▶ Do not replace cable inlets and closures with other types not approved for use in explosive atmospheres.
- ▶ Observe the dimensions of the cable inlets.



DANGER:

Danger of explosion through unsuitable screw fittings and cables

- ▶ Only use cables (according to valid standard) with suitable outer diameters.
- ▶ Protect cables against electrostatic charges.
- ▶ Lay cables in the Ex-area firmly, for example by using cable trays.
- ▶ Only open cable inlets used for cable installation. Keep the plugs. Refit the original plug when a cable inlet must be closed again afterwards.

- SICK AG recommends a tightening torque of 0.5 Nm for the screws of the screw terminals (see [“Connecting the control unit”, page 45](#)).
- The supplied control unit is completely wired. Do not change or manipulate this control unit. Observe the wiring diagram when connecting the control unit.
- Make sure the external grounding connections are present, in good condition, and not damaged or corroded.
- Observe the maximum possible conductor lengths in order to minimize power dissipation.

5.10.1 Accessing the connection terminals



WARNING:

Disconnect the power voltage from the system before removing the terminal cover. Do not restore the power supply to the system until all enclosure covers have been closed.

Live parts may not be accessible after installation.

5.10.2 Instructions for the function of the spring-loaded terminal

Fig. 14: Connecting conductors, schematic diagram

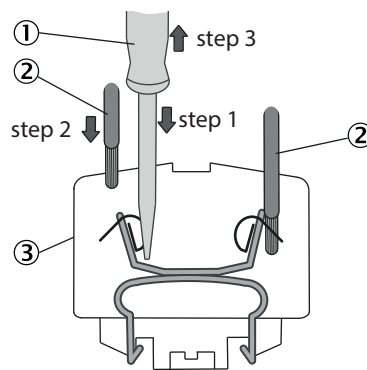

- ▶ Follow steps 1 to 3 to connect the wires.
- ▶ For the spring-loaded terminal position, see [“Connecting the control unit”, page 45](#)
- ▶

- 1 Screwdriver
- 2 Conductor
- 3 Terminal strip

5.10.3 Potential equalization, (PE, ground)

- ▶ Connect the external grounding connection on the enclosure parts of the control unit and the supply unit (see [“ZIRKOR200 Ex-G Electrical connection plan \(Ex-measuring probe and Ex-enclosure\)”, page 47](#)), analyzer electronics enclosure, pneumatic unit as well as the optionally installed solenoid valves directly to the main potential (ground). The required conductor cross-section is 4 mm².

5.10.4 Connecting the control unit

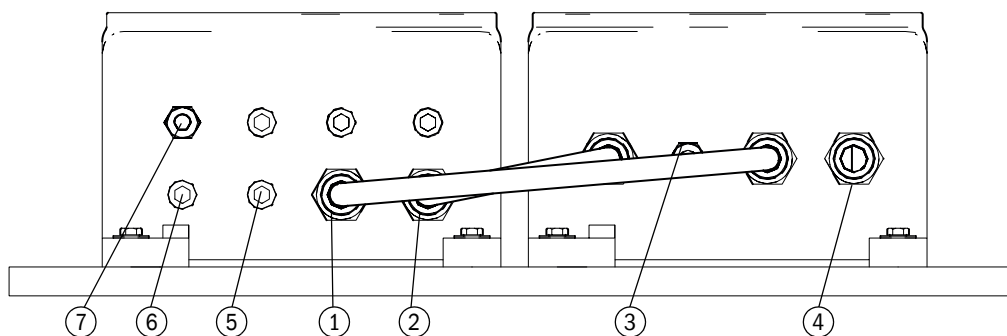

No.	Cable connection	Screw fitting	Cable diameter
1	Internal wiring 1	¾" NPT	16.8
2	Internal wiring 2	¾" NPT	16.8
3	Power connection	½" NPT	6.5
4	Connection cable	1" to ¾" adapter	16.8
5	Solenoid valve of the analyzer unit	½" NPT	6.5
6	Solenoid valve, automatic pneumatic unit	½" NPT	6.5
7	I/O customer interface	½" NPT	6.5

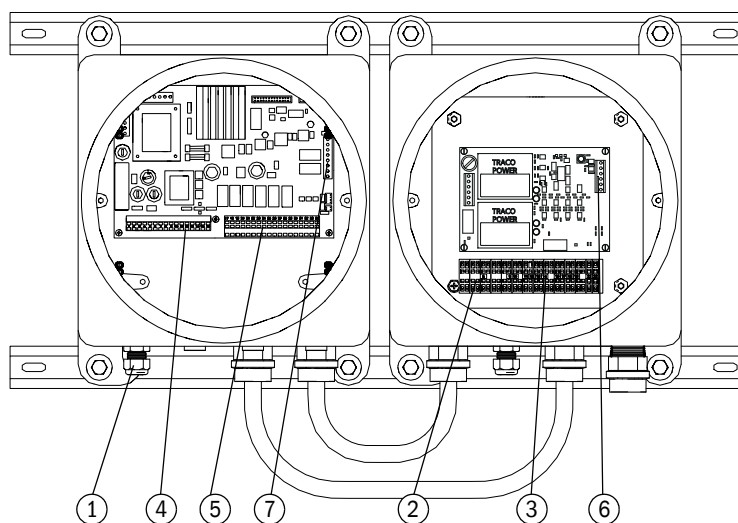

No.	Terminal designation	Terminal number	Terminal type
1	Grounding terminals	--	Screw terminal
2	Power connection terminals	X3.1 - X3.5	Spring terminals
3	Connection cable	X3.6 - X3.12	Spring terminals
4	Internal wiring	X4.1 - X4.16	Spring terminals
5	Signal connection terminals	X5.17 - X5.30	Spring terminals
6	Thermoelements 2a, 2b	X2.H11 - X2.H16	Screw terminal
7	Solenoid valve	X2.1 - X2.2	Spring terminals

5.10.5 Electrical connection plan (Ex-control unit and Ex-analyzer unit)

In order to avoid that line-bound interference influences the control unit, the supplied ferrite sleeves must be mounted as follows

EU conformity is void when these ferrite sleeves are not installed!

Fig. 15: Positions of the ferrite sleeves

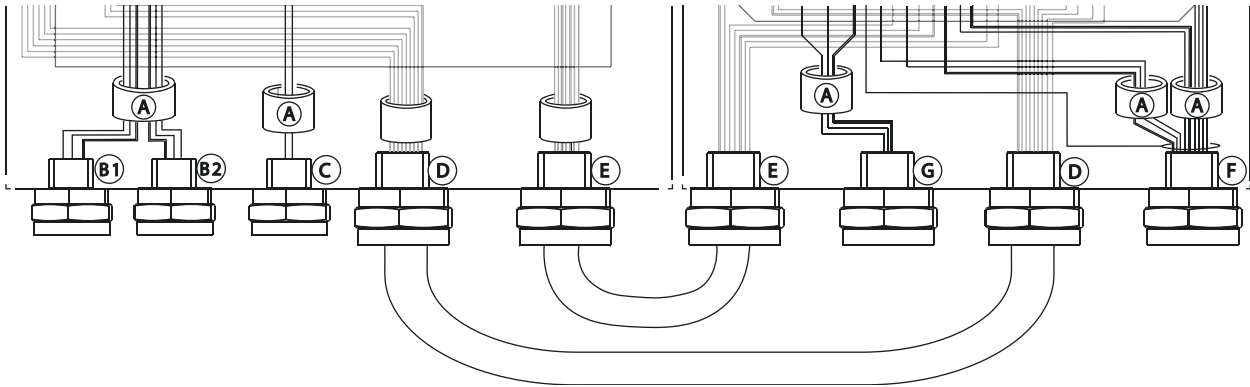

- A Ferrite sleeves
- B1 Pneumatic unit (optional)
- B2 Solenoid valve of the analyzer unit
- C Signal output 4 ... 20 mA O₂ value
- D Connection cable fitted at factory
- E Connection cable fitted at factory
- F Connection cable
- G Main power supply

Fig. 16: ZIRKOR200 Ex-G Electrical connection plan (Ex-measuring probe and Ex-enclosure)

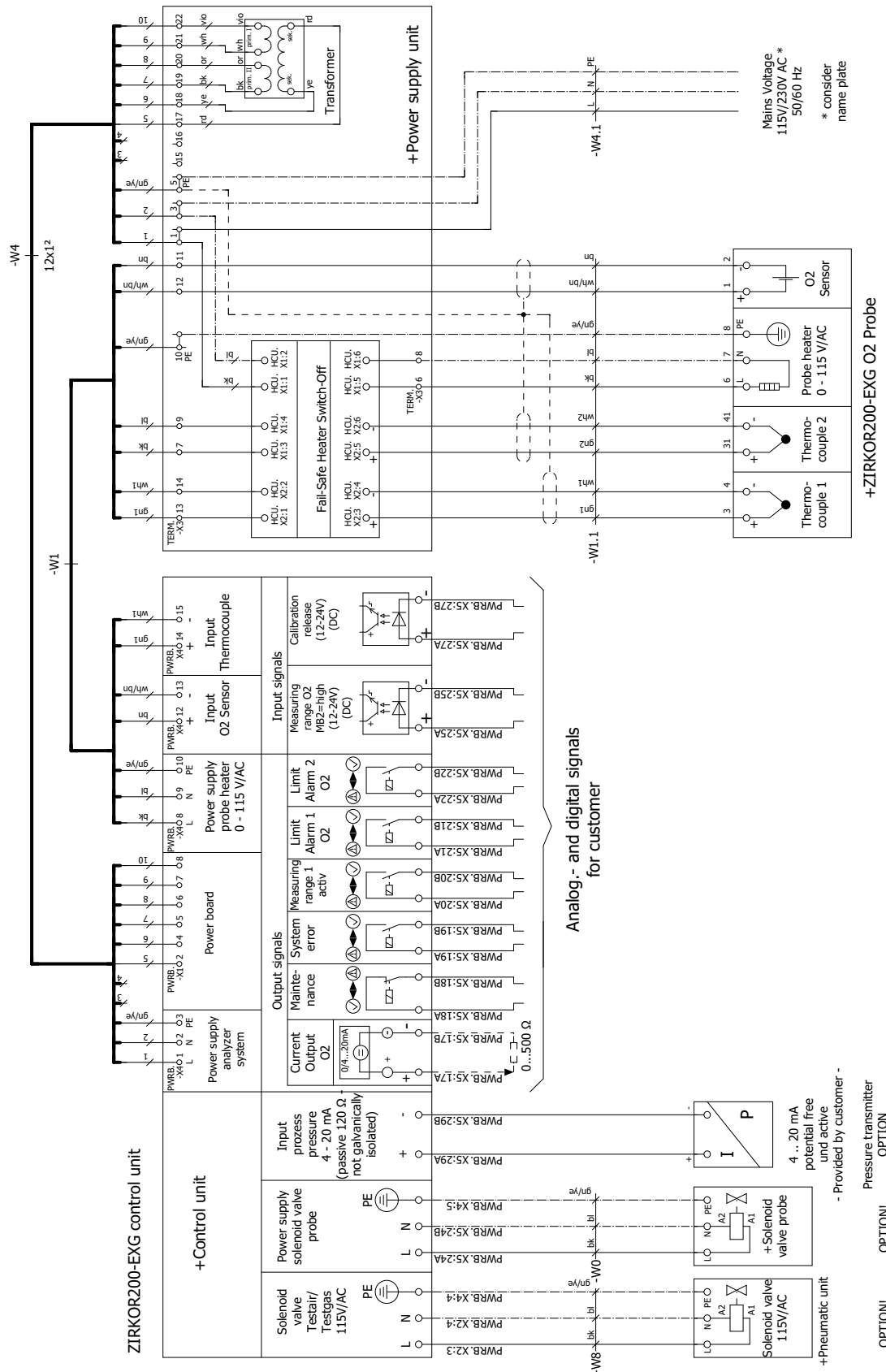

5.10.6 Power connection

Use suitable cable diameters (see [“Installing the control unit”, page 35](#)) and power cable with protective conductor.

- ▶ Lead the power cable through a cable inlet to the lower enclosure section and connect to terminal strip TERM.X3 (see [“ZIRKOR200 Ex-G Electrical connection plan \(Ex-measuring probe and Ex-enclosure\)”, page 47](#) and following Table).

Suitable power voltage/power frequency, see [“Technical data of the control unit”, page 96](#)

Connection terminal	Function
TERM.X3:1	L1 - power voltage - phase
TERM.X3:3	N - power voltage - neutral
TERM.X3:5	PE - protective conductor

5.10.7 Connecting the connection cable to the control unit

Connection terminal	Function	Wire bundle No.	Cross-section (mm ²)	Colors	Additional information
TERM.X3:6	Measuring probe heater	3	1.5	Black	
TERM.X3:8	Measuring probe heater	3	1.5	Blue	
TERM.X3:10	Measuring probe heater	3	1.5	Green-yellow	
TERM.X3:11	Measuring chamber	1	0.75	Brown	With shielding
TERM.X3:12	Measuring chamber	1	0.75	White	With shielding
X2.3	Thermoelement	2a	0.75	Green	With shielding
X2.4	Thermoelement	2a	0.75	White	With shielding
X2.5	Thermoelement	2b	0.75	Green	With shielding
X2.6	Thermoelement	2b	0.75	White	With shielding

5.10.8 Connecting the valve cable of the analyzer unit to the control unit

Connection terminal	Function	Wire bundle No.	Cross-section (mm ²)	Colors	Additional information
PWRB.X5:24A	Solenoid valve		1	Black	
PWRB.X5:24B	Solenoid valve		1	Blue	
X4.5	Solenoid valve		1	Green-yellow	

5.10.9 Connecting the pneumatic unit line to the control unit

Connection terminal	Function	Wire bundle No.	Cross-section (mm ²)	Colors	Additional information
X2.3	Solenoid valve		1	Black	
X2.4	Solenoid valve		1	Blue	
X4.4	Solenoid valve		1	Green-yellow	

5.10.10 Outputs/functions and relay assignment

All relay contacts are designed for 24 V and 1 A ~, 1 A = (exception: Probe valve).

Connection terminal	Relay output	Contact	Function
PWRB.X5:19A/B	System error*	NC contact	Signals operation-critical errors
PWRB.X5:18A/B	Maintenance	NO contact	System code was entered, system in Maintenance mode.
PWRB.X5:20A/B	Measuring range	NO contact	Closed: Measuring range 1 active Open: Measuring range 2 active
PWRB.X5:24A/B	Analyzer unit valve**	NO contact	Control of the analyzer unit valve
PWRB.X5:21A/B	Limit value 1	NC contact	Signal an O ₂ limit value exceeds 1 st limit value
PWRB.X5:22A/B	Limit value 2	NC contact	Signal an O ₂ limit value exceeds 2 nd limit value

* The system error relay is also active during the heating phase.

** The relay contact of the analyzer unit valve is designed for 230 V and 1 A ≅ .

Fig. 17: Relay board with relays and LEDs marked

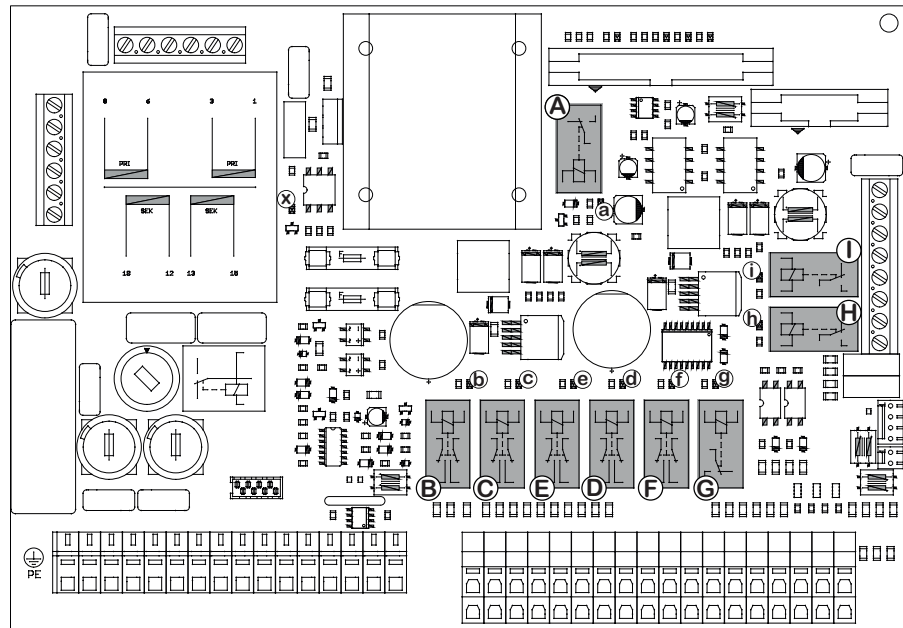

Relay marking	LED marking	Function
A	a	Main measuring probe heater relay
B	b	Maintenance
C	c	System error
D	d	Limit value O ₂ 1
E	e	Measuring range
F	f	Limit value O ₂ 2
G	g	Analyzer unit valve
H	h	Solenoid valve test gas 1
I	i	Solenoid valve test gas 2
	x	Measuring probe heater control

5.10.11 Digital inputs

The digital inputs are designed for a DC voltage of 12 to 30 V for logical “high”. Logical “low” corresponds to a voltage less than 1 V.

Digital input	Function
Adjustment release	External release to start adjustment at ACAL
Measuring range switchover	Activate the 2nd O ₂ measuring range

5.10.12 Installing connection cables

Lead the connection cable through a cable inlet in the lower enclosure section (see “Installing the control unit”, page 35).

- ▶ Lead the connected signal cables out of the potentially explosive atmosphere and connect outside the potentially explosive atmosphere.

5.10.13 Connecting the connection cable

- ▶ Connect the signal cables to the desired connection terminals in the lower enclosure section.

- ▶ For version with additional signal connections (option): Observe the individual information provided.



DANGER:

Electrostatic discharges can destroy electronic components and there is a danger of fire and explosion.

- ▶ Before contact with electrical connections and internal components: Ground the human body and the tool used to discharge electrostatic charges.

Recommended method:

- ▶ When the protective conductor is connected: Touch a blank metal part of the enclosure.
- ▶ Otherwise: Touch a different blank metal surface that is connected to the protective conductor or has safe contact to the grounding.
- ▶ Pay primary attention to any individual information provided.

No.	Connection terminals	Polarity	Function
17	PWRB.X5:17A	+	Current output – O ₂ 0/4 ... 20 mA
	PWRB.X5:17B	-	
18	PWRB.X5:18A	+	Maintenance - Active = closed
	PWRB.X5:18B	-	
19	PWRB.X5:19A	+	System error - Active = open
	PWRB.X5:19B	-	
20	PWRB.X5:20A	+	Measuring range - MBI = closed
	PWRB.X5:20B	-	
21	PWRB.X5:21A	+	Limit value 1 - Active = open
	PWRB.X5:21B	-	
22	PWRB.X5:22A	+	Limit value 2 - Active = open
	PWRB.X5:22B	-	
23	PWRB.X5:23A	+	Solenoid valve of the analyzer unit – power supply
	PWRB.X5:23B	-	
24	PWRB.X5:24A	+	Solenoid valve of the analyzer unit – outlet
	PWRB.X5:24B	-	
25	PWRB.X5:25A	+	Measuring range – 12 ... 24 V DC
	PWRB.X5:25B	-	
26	PWRB.X5:26A	+	NC
	PWRB.X5:26B	-	
27	PWRB.X5:27A	+	Calibration release – 12 ... 24 V DC
	PWRB.X5:27B	-	
28	PWRB.X5:28A	+	NC
	PWRB.X5:28B	-	
29	PWRB.X5:29A	+	NC
	PWRB.X5:29B	-	
30	PWRB.X5:30A	+	NC
	PWRB.X5:30B	-	

- ▶ Connect the signal cables to the desired connection terminals in the lower enclosure section.
- ▶ For version with additional signal connections (option): Observe the individual information provided.

5.10.14 Connecting the analyzer electronics to the connection cable

Fig. 18: Electrical connections on the analyzer unit

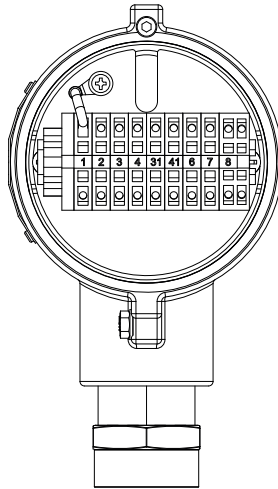

Connection terminal	Function	Wire bundle No.	Cross-section (mm ²)	Colors	Additional information
1	Measuring cell	1	0.75	White (br)	Do not connect the shielding
2	Measuring cell	1	0.75	Brown	Do not connect the shielding
3	Thermocouple 1	2a	0.75	Green	Do not connect the shielding
4	Thermocouple 1	2a	0.75	White	Do not connect the shielding
31	Thermocouple 2	2b	0.75	Green	Do not connect the shielding
41	Thermocouple 2	2b	0.75	White	Do not connect the shielding
6	Measuring probe heater	3	1.5	Black	
7	Measuring probe heater	3	1.5	Blue	
8	Measuring probe heater	3	1.5	Green-yellow	



Note:

Under no circumstances should the shielding of the connection cable be laid to the **probe side**, as this will lead to measurement inaccuracies.

Thread adapter 1"NPT to 3/4" NPT for ATEX approved cable gland 3/4" NPT

5.10.15 Connecting the valve cable of the analyzer unit to the solenoid valve

Fig. 19: Protective conductor connection

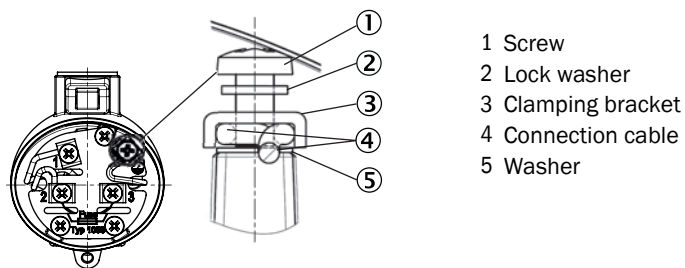
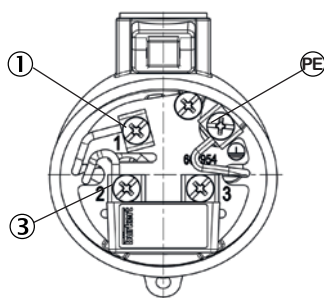

Fig. 20: Terminal connection unit with integrated device protection fuse



Connection terminal	Function	Wire bundle No.	Cross-section (mm ²)	Colors	Additional information
1	Solenoid valve		0.75	Blue	
3	Solenoid valve		0.75	Black	
PE	Solenoid valve		0.75	Green-yellow	

5.10.16 Connecting the pneumatic unit to the solenoid valve

Connection terminal	Function	Wire bundle No.	Cross-section (mm ²)	Colors	Additional information
1	Solenoid valve		0.75	Blue	
2	Solenoid valve		0.75	Black	
PE	Solenoid valve		0.75	Green-yellow	

5.10.17 Closing the enclosure

- ▶ Check all enclosure parts are tightly closed. The rotating covers must be fixed with the clamping screw.
- ▶ Close all cable inlets “flame-tight”. In order to adhere to the ATEX regulations, all cable glands have to be sealed off. The sealing compound is enclosed to the delivery and a detailed processing instruction can be found on the packaging of the sealing compound.



WARNING: Danger of explosion

Open or insufficiently closed cable inlets can lead to sparks escaping the enclosure and causing explosions.

- ▶ Only one thread adapter may be used per cable inlet.
- ▶ Use the sealing compound according to the manufacturer's instructions.

5.11 Pneumatic connections and settings

5.11.1 Pneumatic hose requirements

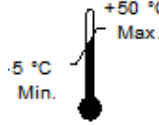
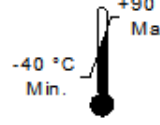
	<p>Observe minimum bending radius. Hose → $R_{min} = 138 \text{ mm}$</p>
 <p>Temperature range - installation</p>	 <p>Temperature range - operation</p>

5.11.2 Preparing the pneumatic hose

Fig. 21: Preparing the pneumatic hose

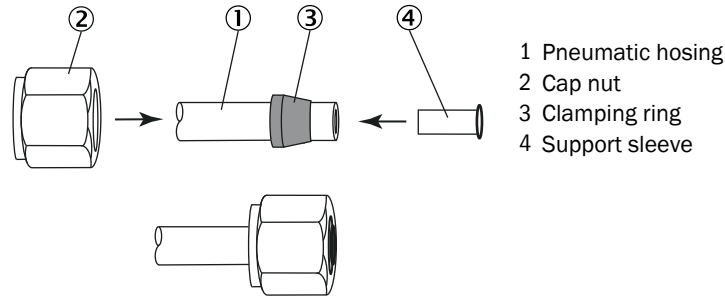

- ▶ Both pneumatic hoses (1) for reference air (blue) and test gas (green) must be prepared with support sleeves (4), clamping rings (3) and cap nuts (2).
- ▶ Tighten the nuts hand-tight and turn a further 1 ¼ turns tight with a wrench.

5.11.3 Pneumatic connections on the analyzer unit

Fig. 22: Pneumatic connections on the analyzer unit

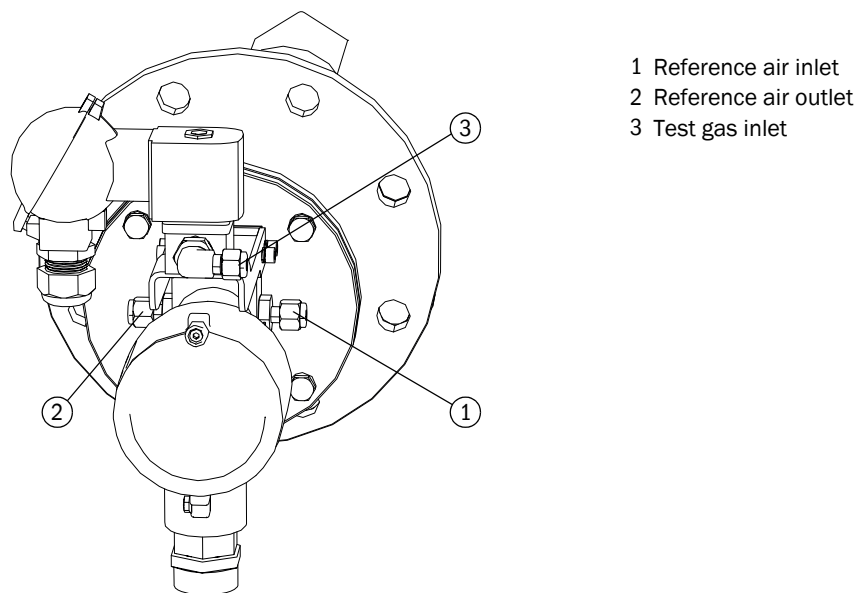

5.11.4 Pneumatic connection, pneumatic unit semi-automatic or fully automatic

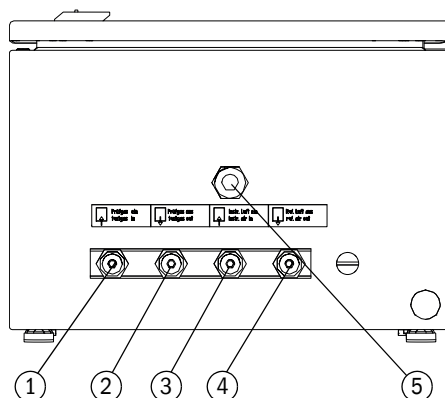

- 1 Test gas inlet
- 2 Test gas outlet - green
- 3 Instrument air inlet
- 4 Reference air outlet - blue
- 5 Cable glands connection cable, control unit - pneumatic unit (only for automatic version)

5.11.5 Test air volumes and reference air volume

The systems are always preset at the factory to the correct test air or reference air volume. The instrument air versions are designed for a primary pressure of 1...10 bar, it might be necessary to adjust the reference air and/or test air volumes for a primary pressure higher than 6 bar.

The air volume should be within the following ranges:

Test air: 150 l/h - 180 l/h

Reference air: 30 l/h - 40 l/h

5.11.6 Setting the flow volume

Adjust the flow volume of reference air and test gas using the flow controller of the respective flowmeter in the pneumatic unit.

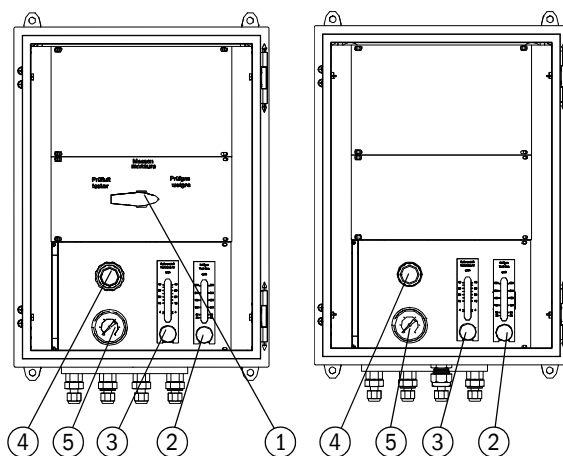

- 1 Manual valve - 3/2-way ball valve (manual version only)
- 2 Test gas flow meter
- 3 Reference air flow meter
- 4 Instrument air / test air pressure regulator
- 5 Pressure gauge

The pneumatic unit in a separate field housing can be installed locally next to the Ex-d analyzer unit. Instrument air and test gas are connected by the customer. The built-in flow meters for reference air and test gas allow flow monitoring during adjustment. Pressure regulators (4) are set to 1 bar at the factory. (see [“Technical specification for the gas supply”, page 98](#))

6 Commissioning

- ▶ Observe the regulations according to IEC 60079-17 during commissioning, maintenance and testing.
- ▶ The device must be completely voltage-free during installation and maintenance. Voltage may only be applied after complete assembly and connection of all circuits required for operation. This also applies to all signal and digital interfaces that are led to/from the device.

6.1 Safety information on commissioning

Technical knowledge needed / requirements for commissioning



Note:

- You are basically familiar with the ZIRKOR200 Ex-G.
- You are familiar with the national and local requirements regarding the installation and operation of equipment in Ex-areas.
- You are familiar with the local situation, especially the potential hazards caused by gases in the gas duct (hot/noxious). You are capable of recognizing and preventing danger by possibly escaping gases.

If one of these requirements is not met:

- ▶ Please contact SICK Customer Service or your local representative.
-

Safety information concerning gas



DANGER:

Risk of burns and poisoning from escaping hot and toxic gas in systems with overpressure conditions

When working on the gas duct, hot gas can escape from the process connection. This can lead to burns or damage to health.

- ▶ Always keep the process connection tightly closed and perform leakage test.
 - ▶ Pay attention to hot surfaces.
 - ▶ Wear appropriate protective equipment.
-

Grounding



CAUTION:

Device damage through incorrect or missing grounding

During installation and maintenance work, it must be ensured that the protective grounding to the devices and/or lines involved is effective in accordance with the applicable standards.

6.2 Checklist before initial commissioning of the system

Before every start-up:

- ▶ Check all enclosures are closed:
 - Enclosure cover
 - Cable inlets
 - Enclosure openings
- ▶ Does the serial number of the analyzer unit match the serial number of the control unit? Assign when not correct. Otherwise follow the procedure [see “Replacing an analyzer unit”, page 74](#).
- ▶ Does the power voltage correspond to the data on the type plate? ([see “Type plates”, page 17](#)) If not, contact SICK.
- ▶ Are the electrical connections made correctly? ([see “Electrical installation”, page 43](#))

- ▶ Is the allocation of the pneumatic connections correct and are the connections gas-tight? (see [“Pneumatic connections and settings”, page 54](#))
- ▶ Make sure there are not leaks on the analyzer unit - is the counter flange welded gas-tight to the flue gas duct, are the flange bolts sufficiently tightened? Were flange gaskets used? (see [“Fitting the analyzer unit”, page 36](#))
- ▶ Do the conditions on site correspond to the specifications in the Data Sheets? (see [“Technical data”, page 87](#))
- ▶ Does the heating monitoring still have a valid calibration/function check (see [“Heating shutdown in case of malfunction”, page 81](#)).

6.3 Operation

In the Ex-area, the ZIRKOR200 Ex-G can only be operated via SICK REMOTE using the ZIRKOR Remote App.

The enclosure must be opened to operate the device via push-buttons. The enclosure may only be opened in an Ex-free environment. The device must not be opened during operation when it is not possible to ensure freedom from explosion hazards.

6.4 Initial commissioning

Before operating the unit, make sure that:

- 1 The enclosure is tightly closed.
- 2 The device power supply is activated at an external location (e.g. main switch).

After switching the device on, the startup screen which also contains the software version is displayed briefly. Afterwards, you will be prompted to select the language, set the system date and time, assign a TAG number and select a SICK REMOTE code (only if SICK REMOTE is activated at the factory).

The measuring probe heating phase begins and then measuring mode starts.

Fig. 23: Initial commissioning. The software version is displayed in the lower right corner.



6.5 Display - heating process

Fig. 24: Display - heating process

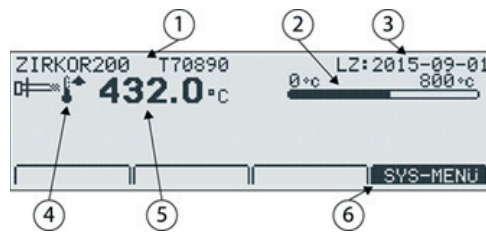

The heating process starts with heating up the O₂ sensor.

- 1 TAG No.
- 2 Temperature, analog display
- 3 Last access, with date
 - ⬆ Rising measuring probe temperature
- 4 ⏱ (or) shows waiting time
 - ⚠ (or) heating fault
- 5 Current temperature
- 6 Softkey: System menu

6.6 Display - Measuring mode

Fig. 25: Display - Measuring mode

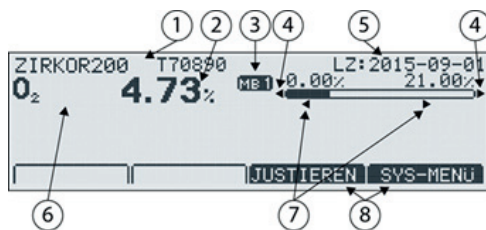

- 1 TAG No.
- 2 Measured value
- 3 Measuring range specification
- 4 Flashing arrow - indicators show measuring range underflow or overflow
- 5 Last access, with date
- 6 Measuring component
- 7 Analog display shows measured value and range indicator - min-alarm / max-alarm *
- 8 Softkey name

* Only when O₂ limit value alarms are switched on and the defined limit values are within the measuring range.

6.7 Operating elements and display

Fig. 26: Operating elements and display

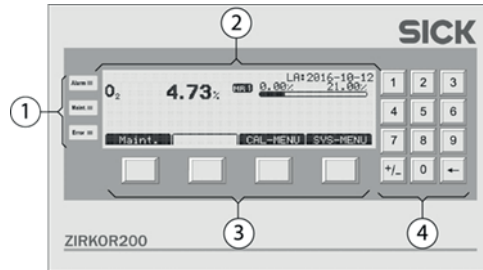

The controls and display of the ZIRKOR200 are located in the control unit and comprise:

- 1 Three LED indicators for active status messages
- 2 Graphics-capable, backlit display
- 3 Four function keys with changing assignment (softkeys)
- 4 Numeric keypad for numerical input

6.8 Status LEDs

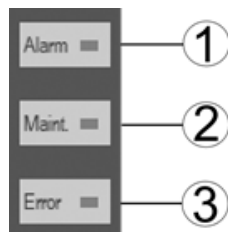

- 1 Alarm, orange - lights when an alarm is present (e.g. O₂ limit value alarm).
- 2 Maintenance, orange - lights when a system function is called up that may influence the O₂ measured value.
- 3 Error, red - lights when a system error occurs.

6.9 Softkey symbols

	Moves a selection up one position
	Moves a selection down one position
	Exit selection
	Cancel function or entry
	Select or confirm a function / value

6.10 System code



Note:

The system code is 0000 on delivery. In this state, system changes are possible without code entry. The system code protects the configuration data of the system against unauthorized users. Functions that can influence the O₂ measurement are also secured in this way.

Caution: After commissioning, change the system code to secure the system configuration data against unauthorized users. Keep the changed system code in a safe place.

7 Menu overview and explanations

7.1 SYS-MENU

SYS-MENU		
System information		
<input checked="" type="checkbox"/>	Current measured value	
	O ₂ measured value (% O ₂) (optionally ppm)	
	O ₂ -mA output 17A/B (mA)	
	O ₂ sensor input (mV)	
	Reference air flow volume	
	O ₂ probe temperature (°C / °F)	
	O ₂ probe heating capacity (%)	
	Thermovoltage input (mV)	
	Terminal temperature (°C / °F)	
	Internal temperature (°C / °F)	
	Process pressure (rel.) (mbar/psi)	
	O ₂ -Sensor life expectancy (%)	
	Lambda	
Adjustment results		
	e.g. 2012-05-11 (select data/time)	
	Performed on	
	Adjustment method	
	O ₂ sensor adjustment	
	~~ Adjustment results ~~	
	O ₂ value with test air (% O ₂)	
	◆ adjusted to	
	O ₂ value with test gas (% O ₂)	} Only visible when performed
	◆ adjusted to	
	~~ Adjustment data ~~	
	O ₂ -Sensor offset (mV)	
	O ₂ -Sensor slope (mV / dec)	} 2-point adjustment only
	~~ Test gas data ~~	
	Test air (% O ₂)	
	Test gas (e.g. 2.1% O ₂)	
	~~ Sensor raw data~~	
	O ₂ voltage with test air (mV)	
	◆ At pressure (mbar/psi)	
	O ₂ voltage with test gas (mV)	} Only visible when performed
	◆ At pressure (mbar/psi)	

SYS-MENU		
		O ₂ reaction to test gas (s) } Only visible when performed
		O ₂ reaction to process (s) } Only visible when performed
		O ₂ -Sensor life expectancy (s)
		Device operating data
		Switch-on cycles
		Operating hours
		Min. internal temperature
		Max. internal temperature:
		Software version and option
		<input checked="" type="checkbox"/>
		Software ZIRKOR200
		~~ Options ~~
		◆
		System configuration
		O₂ measuring range
		<input checked="" type="checkbox"/>
		Measuring range 1, from (% O ₂ , ppm O ₂)
		Measuring range 1, to (% O ₂ , ppm O ₂)
		Measuring range 2, from (% O ₂ , ppm O ₂)
		Measuring range 2, to (% O ₂ , ppm O ₂)
		Measuring range selection with (Dig. input / key)
		Measured value average over (s)
		Conversion wet → dry (% H ₂ O)
		mA output type (0-20 mA / 4-20 mA)
		mA output for system fault (mA)
		O₂ limit value alarms
		O ₂ limit value alarm 1 (ON / OFF)
		◆ at } Only visible when "ON"
		◆ Hysteresis
		O ₂ limit value alarm 2 (ON / OFF)
		◆ at } Only visible when "ON"
		◆ Hysteresis
		O₂ sensor adjustment values
		O ₂ adj value - offset (mV)
		O ₂ adj value - slope (mV/Dek)

SYS-MENU		
Adjustment setting		
	Time per test gas feed (min.)	
	Stopping time to process (min.)	
	Hold measured value at Just. (ON/OFF)	ON: The last valid measured value from the process is held for adjustment duration.
	Auto. Adjustment (ON/OFF)	
↑	↓	◆ Adjustment method (1-point / 2-point) } Only visible when "ON"
↑	↓	◆ Test gas (cylinder value) {only for 2-point adjustment} } Only visible when "ON"
	◆ Start by (time, digital input, both)	} Only visible when "ON"
	◆ Interval (days)	} Only on "time" and "both"
	◆ Next AJUST (date)	Adjustable
←	←	←
Process pressure input range		
	Pressure range from (mbar)	
↑	Pressure range to (mbar)	
↓	Site altitude above sea level (m)	
←		
System clock/TAG No.		
✓		
↑	System data [yyyy.mm.dd]	
↑	System time [hh:mm:ss]	
↓	TAG	
←		
REMOTE - settings (optional)		} Visible when REMOTE interface is activated.
✓		
	REMOTE (ON/OFF)	
↑	REMOTE code (8-digit code)	} Visible when REMOTE is on.
↓	Range (short / medium / maximum)	
←		
Units of measure		
✓		
↑	Temperature (°C / °F)	
↓	◆ Pressure (mbar/psi)	
←		
Language		
✓		
↑	Select language (German / English / Spanish / Polish / French)	
←		
Change system code		
✓		
←		

SYS-MENU	
	Load default set.
⬆	✓
⬇	←
	Service
⬅	←

7.2 Menu explanations

7.2.1 O₂ measuring ranges (scaling)

Fig. 27: O₂ measuring ranges

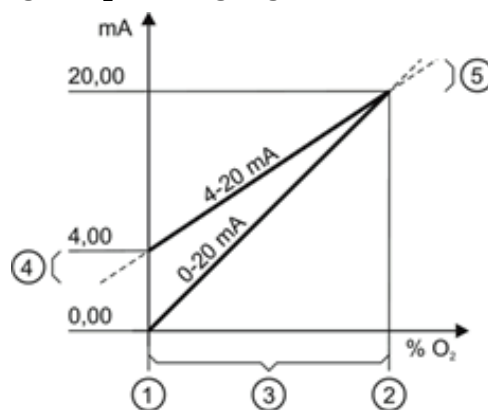

O₂ measuring range (3) specifies the linear scaling of the O₂ measured value as analog output value (mA).

“O₂ measuring range from” (1) defines the O₂ value at which the analog output signal should be 4.00 mA (4-20 mA) or 0.00 mA (0-20 mA). “O₂ measuring range to” (2) defines the O₂ value at which the analog output signal should be 20.00 mA.

Only 4-20 mA: A measuring range underflow (4) exists when the O₂ measured value falls below the value defined in “O₂ measuring range from”. The analog output signal is limited to a minimum of 3.60 mA for the O₂ measured value output.

A measuring range overflow (5) exists when the O₂ measured value rises above the value specified in “O₂ measuring range to”. The analog output signal is limited to a maximum of 20.40 mA for the O₂ measured value output. Measuring range underflows and overflows are shown on the display (measuring mode).

7.2.2 Measured value average over [s]

This entry defines the time span up to 60 seconds for continuous averaging (rolling average). During an adjustment as well as a sensor check, averaging for the O₂ measurement display is switched off, the signal at the analog output is still averaged.

7.2.3 mA output for system error

Sets the mA output value in the range 0 to 3.55 or 20.41 to 20.80 mA in the event of a system error. The mA output value in case of a system error cannot be within the mA measuring range.

7.2.4 O₂ limit value alarms

Fig. 28: O₂ limit value alarm settings

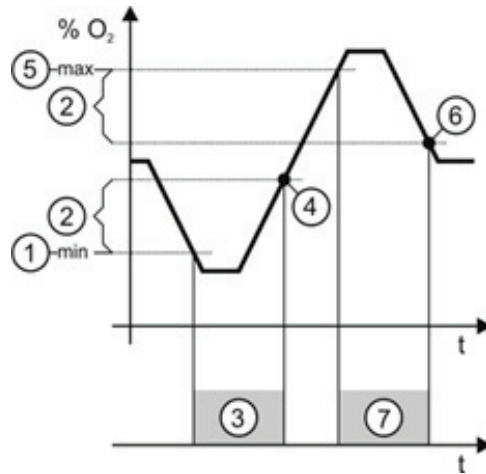

The entry “at” defines the O₂ value from which the O₂ limit value alarm is to be signaled.

With the O₂ limit value alarm function “min” (1), limit value alarm (3) is triggered when the O₂ measured value falls below the defined O₂ limit value “min”.

If a hysteresis unequal to 0.00% O₂ is defined (2), the limit value alarm is reset when the O₂ measured value rises above the O₂ limit value *plus* hysteresis value (4).

With the O₂ limit value alarm function “max” (5), limit value alarm (7) is triggered when the O₂ measured value rises above the defined O₂ limit value “max”.

If a hysteresis unequal to 0.00% O₂ is defined (2), the limit value alarm is reset when the O₂ measured value drops below the O₂ limit value *minus* hysteresis value (6). If the hysteresis is set to 0.00% O₂, the O₂ limit value alarm must be reset manually on the device.

7.2.5 O₂ sensor adjustment values

A 1-point adjustment should be carried out every 4-6 weeks and a 2-point adjustment every 6 months.

With EMI, a 1-point adjustment should be carried out every 3 days and a 2-point adjustment every 6 months.



Note:

The O₂ sensor adjustment values can be changed by a 1- or 2-point adjustment. Manual entry is only necessary after replacing the O₂ probe.

7.2.6 Time per test gas feed

Defines the time per test gas feed (test air feed) during a sensor adjustment. If the sensor stability is not reached within the preset maximum time, the adjustment is aborted with the error message:

“O₂ sensor adjustment failed - O₂ sensor signal unstable”. Extend the time when this error message appears.

The maximum time set at the factory is 10 minutes. If necessary, the time can be set between 5 and 30 minutes.

7.2.7 Stopping time until process (O₂)

The entry determines, on the one hand, the stopping time of the measured value memory (when switched on) after the test gas feed (test air feed) has been completed, and, on the other hand, the time for which the O₂ trend display should still be shown on the display after the test gas feed (test air feed) has been completed during sensor adjustment.

7.2.8 Auto. Adjustment (ACAL)

The automatic adjustment enables a cyclic, time-controlled or remote-controlled adjustment of the sensors via the digital input provided for this purpose. The automatic adjustment can be globally switched on or off. It only starts from the main measured value display.

When an ACAL 2-point is set, a test gas cylinder must be permanently connected and turned on.



Note:

Make sure the test air and test gas flow volumes required for adjustment are set correctly.

For systems *with flow monitoring*: The flow volumes can be checked via System check --> Sensor check and adjusted if necessary.

For systems *without flow monitoring*: Check the flow volumes using an external flow meter and, if necessary, set to 150 - 180 l/h using an external throttle valve.

7.2.9 Settings for auto. adjustment

The settings for automatic adjustment are only visible when automatic adjustment is switched on globally. The adjustment method determines whether the automatic adjustment should be carried out as a 1-point adjustment with test air only or as a 2-point adjustment with two test gases (test air / test gas). The required concentrations of the test gases can be entered depending on the adjustment method. Test air (ambient air) is preset with a fixed O₂ concentration of 20.95%; this value is therefore neither displayed nor can it be changed.

The automatic adjustment starts via:

- **Time:** Time-controlled start with fixed intervals. The interval time (in days) as well as the time of the next execution (next ACAL) can be defined here. The entry for the next execution also allows a date/time before the system time, but this is then automatically corrected to the system time + interval.
- **Time + digital input:** Same as "Time", additionally a control voltage of 12...24 V DC must be applied to the digital input "Adjustment release" to start the automatic adjustment.
- **Digital input:** Automatic adjustment is started as soon as a control voltage of 12...24 V DC is applied to the digital input "Adjustment release". A new automatic adjustment is started immediately when the control voltage on the digital input is maintained after adjustment.

7.2.10 REMOTE

**Note:**

REMOTE is disabled by default, so the password and range are not shown. After activation (only possible from system level), the 8-digit password which is prompted during the remote connection setup must be assigned.

The password is used:

- For authentication and pairing with a smartphone/tablet/notebook/PC.
- For authentication/login after each connection establishment. Without authentication/login, neither device data can be read out nor the device configuration changed.

The **range** limits the transmission power of the REMOTE module. **Maximum** = approx. 100 m, **medium** = approx. 10 m, **short** = approx. 1 m. The actual possible range can vary greatly due to local conditions and the reception performance of the smartphone used.

Fig. 29: REMOTE connection active

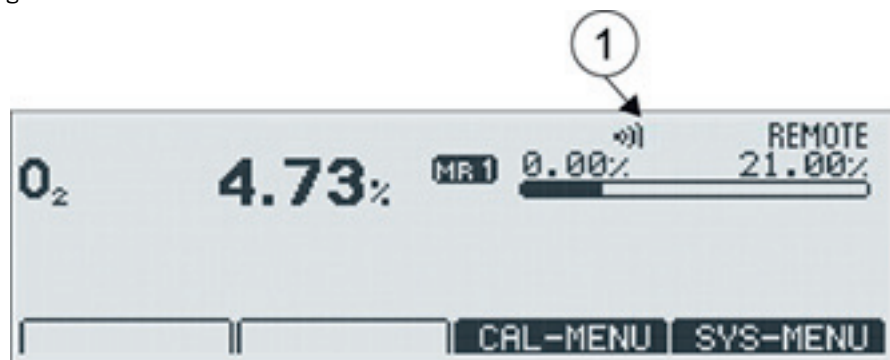

If a SICK-REMOTE connection to the analyzer is active, the connection is shown in the upper right corner of the display (1).

**HINTS:**

A maximum of 16 users (smartphones / tablets) can be connected to the REMOTE module of a SICK analyzer. The connection fails when additional users try to connect. In this case, REMOTE must be switched off and on again via the front panel, all mobile devices that have already been connected to the device once must be registered to it again.

7.2.11 Units of measure

Sets the units of measurement for temperature (°C / °F) and pressure (psi / mbar).

7.2.12 Language

Sets the language for all display texts. The languages German, English, Spanish, Polish and French are available.

7.2.13 Change system code

The system code protects the system configuration against unauthorized use. Settings that may influence the measurements are also protected.



Note:

The system code is 0000 on delivery.

Note the new system code and keep the information in a place accessible only to those authorized to make changes to the system. If the system code is lost, it can only be restored by a trained service technician.

7.2.14 Loading the factory settings

Restores the delivery status of the system. All values changed in the meantime as well as the O₂ sensor adjustment values and adjustment results are lost. Write down all O₂ sensor adjustment values beforehand and enter them again afterwards. A new adjustment must be carried out when this is not done.

7.2.15 Service (factory service settings)

The service functions may only be called up by trained service technicians. They are protected by their own service code, which is independent of the system code.

7.2.16 Adjustment menu

Adjusting	
<input checked="" type="checkbox"/>	
<input type="checkbox"/> 1-point adjustment, O ₂	
<input type="checkbox"/> 2-point adjustment, O ₂	
<input type="checkbox"/>	

7.2.17 Display - Adjustment

Fig. 30: Display - here, a 1-point adjustment

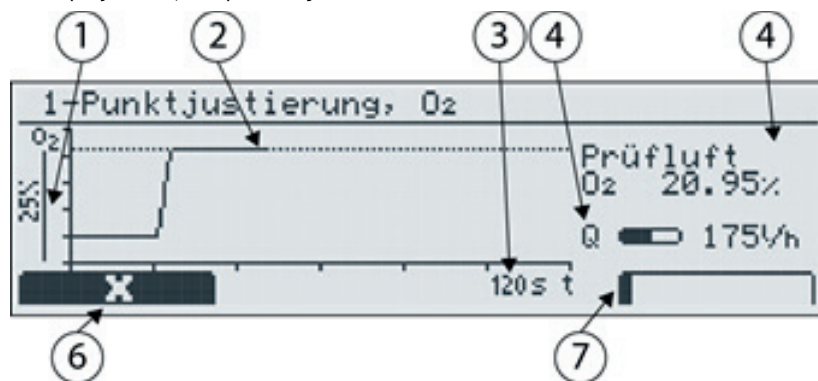

1	Measured value scale - shows the scale value (corresponds to the maximum adjustable measuring range).
2	Trend display O ₂ measured value _____ and O ₂ target value The target value is given by the O ₂ concentration of the test gas/test air.
3	Time scale of the respective test gas feed in seconds. The time specification refers to the end of the time scale
4	Current flow volume (only with flow monitoring option)
5	Current O ₂ measured value

6	Cancel adjustment
7	Progress bar

Fig. 31: The 3 phases of a 2-point adjustment; Test gas feed, test air feed and return to process.

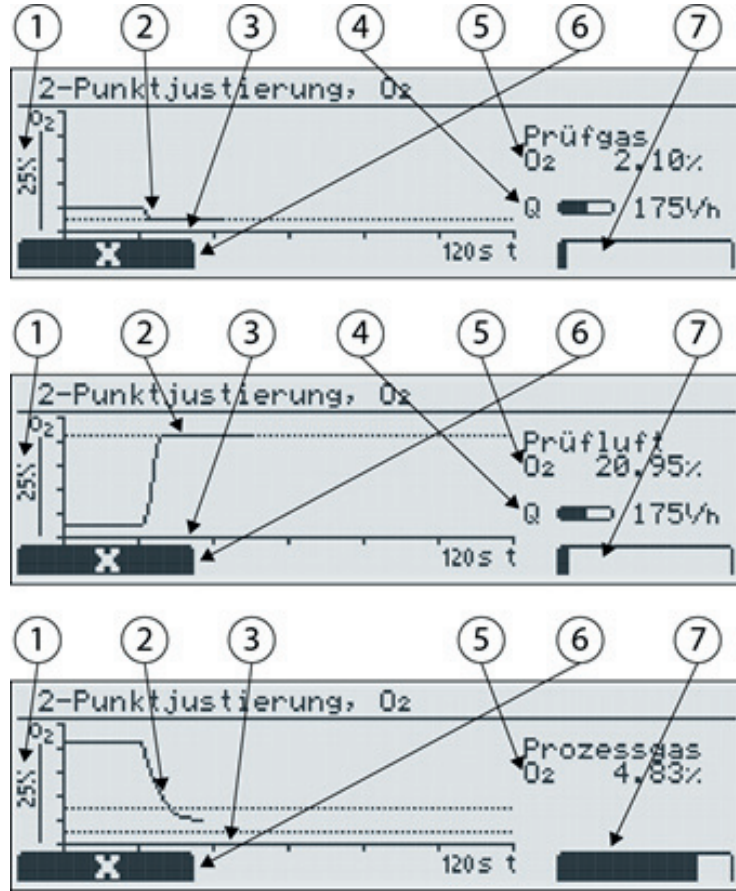

Note:

The test gas concentration for test air is not entered because it is known (20.95% O₂). The test gas concentration(s) is (are) only entered after the test gas/process gas feed processes.

7.2.18 1-point adjustment (manual)

The adjustment value **Offset** is determined during 1-point adjustment of the sensor. For this purpose, test air (test gas 1) is fed to the sensor. For systems without integrated pneumatics, the test air feed (test gas 1 feed) must be performed manually, i.e. by the user, and the test gas flows must be checked and, if necessary, readjusted.

Sequence

- 1 System code entry
- 2 Maintenance signal is set
- 3 Prompt for test air feed (*only appears for systems without flow monitoring*)
- 4 Adjustment with test air
- 5 Prompt to terminate test air feed (*only appears for systems without flow monitoring*)
- 6 Display of the process return when the difference between the previously measured O₂ concentration in the process and the O₂ concentration with test air is more than 3.00%
- 7 Entry O₂ concentration test gas 1 (*not applicable for test air*)
- 8 Display of adjustment results (*max. 1 minute*)

- 9 Maintenance signal reset (*delayed after last test gas monitoring by the “Stopping time until process” when “Hold measured value during adjustment” is switched on*)
- 10 Return to main measured value display









7.2.19 2-point adjustment (manual)

During 2-point adjustment of the sensor, adjustment values **Offset** (constant) and **Slope** (steepness) are determined. For this purpose, two test gases are fed to the sensor. For systems without integrated pneumatics, test air/test gas feed must be performed manually, i.e. by the user, and the test gas flows must be checked and, if necessary, readjusted.

Sequence

- 1 System code entry
- 2 Maintenance signal is set
- 3 Prompt for test gas feed (*only appears for systems without flow monitoring*)
- 4 Adjustment with test gas (*test gas 1*)
- 5 Prompt for test air feed (*only appears for systems without flow monitoring*)
- 6 Adjustment with test air
- 7 Prompt to terminate test gas feed (*only systems without internal flow monitoring*)
- 8 Display of the process return when the difference between the previously measured O₂ concentration in the process and the O₂ concentration with test air is more than 3.00%
- 9 Prompt for test gas concentration(s)
- 10 Display of adjustment results (*max. 1 minute*)
- 11 Maintenance signal reset (*delayed after last test gas monitoring by the “Stopping time until process” when “Hold measured value during adjustment” is switched on*)
- 12 Return to main measured value display

7.3 System check

O₂ sensor check		
	Source: Test air O ₂ sensor .. mV = ... % Flow.. l/h	
	Source: Test gas O ₂ sensor .. mV = ... % Flow (3 bar max) .. l/h	
	Source: Process O ₂ sensor .. mV = ... %	
		
Check mA outputs		
	Set mA output 17A/B (mA)	
		
Check relay outputs		
	Relay contact on 18A/B (open / closed)	
	Relay contact on 19A/B (open / closed)	
	Relay contact on 20A/B (open / closed)	
	Relay contact on 21A/B (open / closed)	
	Relay contact on 22A/B (open / closed)	
		
Check digital inputs		
	Input status on 25A/B	
	Input status on 27A/B	
		
Check mA inputs		
	Check mA input on 29A/B	
		

8 Maintenance

8.1 Technical knowledge necessary for maintenance work



Note: Malfunction hazard

Only technicians with special ZIRKOR200 Ex-G training are allowed to perform maintenance tasks on the ZIRKOR200 Ex-G.

8.2 Safety instructions for maintenance work



DANGER: Danger of explosion due to damaged measuring probe

A cold measuring probe can be damaged by condensed, corrosive flue gas, as a result of which the analyzer unit is no longer encapsulated in a flameproof enclosure and can lead to explosions.

- ▶ The analyzer unit must be in operation while in the process.



DANGER: Danger of explosion through hot surfaces

The measuring probe can be heated by the process. When withdrawn from the process, the temperature of the measuring probe may be higher than the surface temperature certified for the environment (see Ex-marking) and can lead to an explosion.

- ▶ Only remove hot measuring probe from the duct in an Ex-free environment.



WARNING: Hot surface

The measuring probe is heated by the process and may cause burns during and after removal from the duct.

- ▶ Wear suitable protective clothing.
- ▶ Perform work on the analyzer unit after it has cooled down.



DANGER: Hazard by voltage

There is a risk of electric shock when working on the device with the voltage supply switched on.

- ▶ Only carry out maintenance work when the device is disconnected from the power supply.
- ▶ The voltage supply may only be switched on again after work completion or for test purposes by the persons carrying out the work under consideration of the valid safety regulations.



WARNING: Risk of chemical burns/poisoning through caustic/toxic residues on components with sample gas contact

After the device has been decommissioned or removed from the measuring channel, process gas residues can exist as deposits on components with sample gas contact (e.g., gas filter, gas-carrying lines etc.). These residues can be odorless or invisible depending on the gas mixture in the duct. Without protective clothing, contact with such contaminated components can lead to severe burns or poisoning.

- ▶ Take appropriate protective measures for work (e.g., by wearing a safety mask, protective gloves and acid resistant clothes).
- ▶ In case of contact with the skin or eyes, rinse the affected parts immediately with clear water and consult a doctor
- ▶ Decontaminate all contaminated components according to regulations after disassembly.

8.3 Information on use in Ex-areas



DANGER:
Danger of explosion when using spare or expendable parts not approved for the Ex-area

All spare and expendable parts for the in-situ gas measuring device are tested by SICK for use in Ex-areas. The use of other spare and expendable parts will invalidate the claim against SICK because the ignition protection cannot be guaranteed.

- ▶ Use only original spare parts and expendable parts from SICK.



DANGER:
Danger of explosion through residual voltages and hot surfaces in the device

Danger of explosion during installation and maintenance work on the device.

- ▶ Ensure the work area is Ex-free when working on the device.
- ▶ Perform calibration with closed enclosure cover using SICK Remote.

8.4 Maintenance plan

In general, the maintenance work to be carried out and the necessary maintenance interval depend on the flue and/or process gas conditions in which the analyzer unit is installed. Therefore, the appropriate maintenance interval can vary from a few months up to several years.

The main influencing factors are the presence of corrosive components such as SO₂ or HCl, a continuous reducing atmosphere (reduced oxygen concentration, increased concentration of combustible gases) and the nature of the solid components in the sample gas. These may have the following effects: chemical or mechanic damage to the measuring probe, clogging of the filter element or accelerated aging of the sensor. This can lead to both a falsification of the measured values and an increase in the response time, which can subsequently lead to an incorrect process operation.

For this reason, a sensor check is recommended with test gas and test air every six months. A 2-point calibration should be carried out after a serious deviation between the values obtained and those presently anticipated. A visual inspection of the analyzer unit, which includes cleaning the filter element if necessary, should be conducted at least once a year.

Deviating from these recommendations, the operator must define a suitable maintenance interval for his process and measuring location that is appropriate to the safety relevance of the measurement and the conditions of the process.

Maintenance interval ^[1]			Maintenance work
1M	6M	1Y	
x	x	x	Measured value plausibility check
	x	x	Check with test air and gas: <ul style="list-style-type: none"> - Check sensor adjustment values - Check the solenoid valve (optional) - Check the flow volumes
	x	x	(As required) Adjustment of the sensor
	x	x	Visual check of the analyzer unit: <ul style="list-style-type: none"> - Check the measuring probe and the filter head and clean as necessary - Check for corrosion - General check of the flameproof enclosure (see “Visual check of the flameproof enclosure”, page 76)

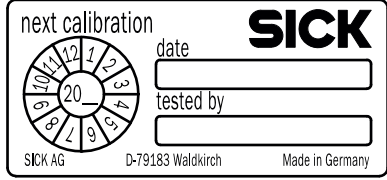
Maintenance interval ^[1]			Maintenance work
1M	6M	1Y	
	x	x	Check the calibration date of the heating monitoring 
		x	Visual check of the flameproof enclosure of the control unit (see “Visual check of the flameproof enclosure”, page 76)
		x	Visual check of cables and hoses for external damage

[1] M = month(s), Y = year(s)



Deviating from these recommendations, the operator must define a suitable maintenance interval for his process and measuring location that is appropriate to the safety relevance of the measurement and the conditions of the process.

8.5 Tools required

Tools
3 mm Allen key
4 mm Allen key
Cross-head screwdrivers in different sizes

8.6 Maintenance work

8.6.1 Replace fuses

- ▶ Open the locking screw to open the enclosure. Make sure not to damage the thread.
- ▶ Replace the corresponding fuses, see “Position of the fuses”, page 73.
- ▶ Close the housing with the locking screw with 5 turns. Make sure not to damage the thread.

Fig. 32: Position of the fuses

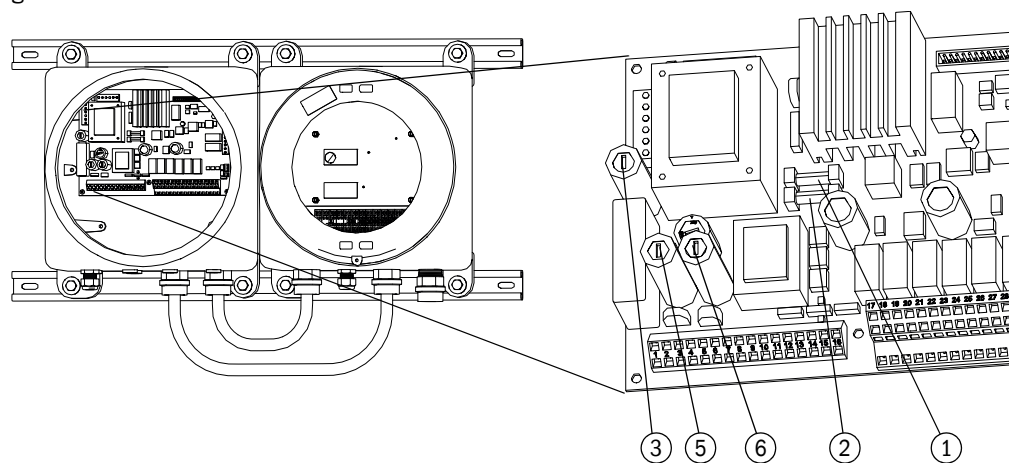

	Fuse	Rated current	SICK Part No.	Type	Task
1	F3	0.5 A	2116785	Slow 5x20 mm glass tube fuse	To protect the electronics
2	F4	0.5 A		Slow 5x20 mm glass tube fuse	To protect the electronics
3	F5	1 A		Medium slow 5x20 mm glass tube fuse	To protect the 115 V AC solenoid valves as well as the test and reference air pump
5	F1	2.0 A (230 V AC) 4.0 A (115 V AC)		Slow 5x20 mm ceramic tube fuse	To protect the entire system
6	F2	4 A		Medium slow 5x20 mm ceramic tube fuse	To protect the measuring probe heater

All fuses listed in the Table are available as a spare parts set under the SICK Part No. 2089370 E-SET FUSES.

8.6.2 Replacing the filter head



WARNING: Danger of explosion through breaching the flameproof enclosure

An Allen screw, damaged due to incomplete loosening during filter replacement or a loose Allen screw can damage the flameproof enclosure by damaging the flameproof joint and thus lead to an explosion.

- ▶ Loosen and tighten the hexagon socket screw completely.
- ▶ Replace damaged hexagon socket screws.



WARNING: Danger of burns on hot components which are in the process gas

The temperature of the filter head and all parts in the process gas is 150 °C to 800 °C (302 °F to 1472 °F) during operation. Directly touching the parts for disassembly or maintenance causes serious burns.

- ▶ Use heat protection gloves when removing the measuring probe.
- ▶ Switch the electronics supply voltage off before removing the measuring probe.
- ▶ Place the analyzer unit in a safe, protected area after removal and wait until the measuring probe temperature has cooled down to the ambient temperature.

- ▶ To replace the filter head, loosen the locking screw on the filter head.
- ▶ The filter head can now be unscrewed and removed.
- ▶ Screw the new filter head to the measuring probe.
- ▶ Before tightening the locking screw again, align the V-shield towards the flue gas flow.

8.6.3 Replacing an analyzer unit



WARNING: Risk of burns

The temperature of the filter head and all parts in the process gas is 150 °C to 800 °C (302 °F to 1472 °F) during operation. Directly touching the parts for disassembly or maintenance causes serious burns.

- ▶ Use heat protection gloves when removing the measuring probe.
- ▶ Switch the electronics supply voltage off before removing the measuring probe.
- ▶ Place the analyzer unit in a safe, protected area after removal and wait until the measuring probe temperature has cooled down to the ambient temperature.

- 1 Disconnect the connection cable analyzer electronics - control unit in the control unit.
- 2 Loosen the counter flange bolts and remove the analyzer unit.
- 3 Install the new analyzer unit with a new seal. Determine the flow direction of the flue gas and align the V shield (see "Aligning the V-shield", page 39).
- 4 Fasten the counter flange bolts and connect the connection cable in the control unit.
- 5 Switch on the supply voltage and wait until the measuring probe has reached the setpoint temperature.
- 6 Perform a 2-point adjustment under process conditions.

8.6.4 Replacing the O₂ measuring cell



Note:

It is only necessary to replace the measuring cell if it leaks (jumping or incorrect measured values) and a two-point adjustment was faulty.



WARNING: Risk of burns

The temperature of the filter head and all parts in the process gas is 150 °C to 800 °C (302 °F to 1472 °F) during operation. Directly touching the parts for disassembly or maintenance causes serious burns.

- ▶ Use heat protection gloves when removing the measuring probe.
- ▶ Switch the electronics supply voltage off before removing the measuring probe.
- ▶ Place the analyzer unit in a safe, protected area after removal and wait until the measuring probe temperature has cooled down to the ambient temperature.

Fig. 33: Replacing the O₂ measuring cell

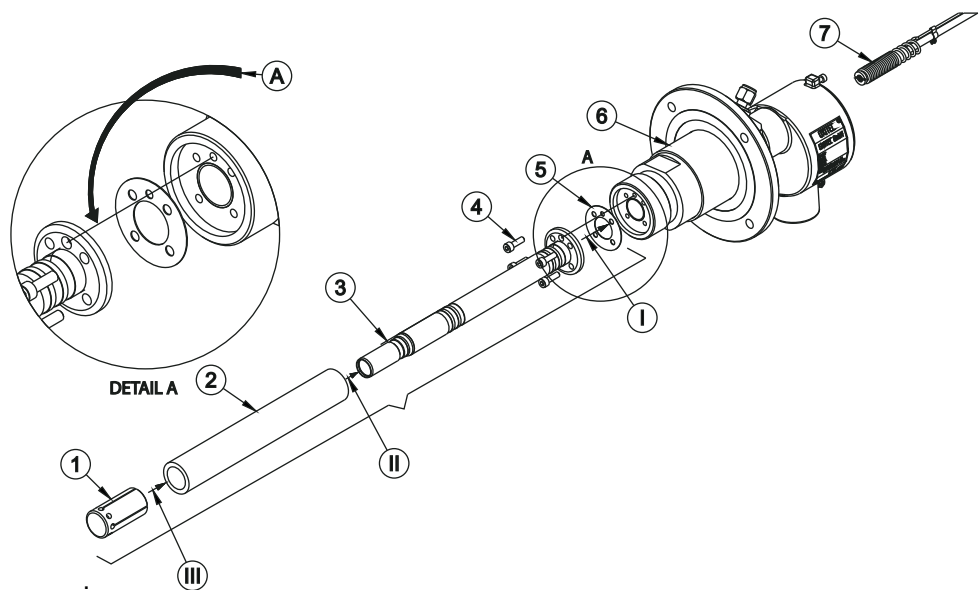

- 1 Dummy plug
- 2 Volume reducer
- 3 O₂ sensor with flange
- 4 4 M5 x 12 screws
- 5 Sensor flange seal
- 6 Measuring probe
- 7 Measuring probe inner part

- ▶ Disconnect the conductors in the measuring probe inner part and loosen the two hexagon socket screws holding the holding bolt on the neck tube. Remove the thin, transparent reference air hose from the feed-through fitting on the analyzer electronics.
- ▶ Now carefully pull out the inner part of the measuring probe (4-hole ceramics rod with measuring signal wire, thermoelement and heating) **straight**.

- ▶ Loosen the 4 hexagon socket screws on the measuring cell flange and remove the measuring cell from the measuring probe.
- ▶ Clean the flange on the measuring probe with fine sandpaper.
- ▶ When assembling, the volume reducer must be installed so that the product is Ex-compliant.
- ▶ Screw the new measuring cell with new seal and 4 new screws to the measuring cell flange of the measuring probe.
- ▶ Tighten the 4 hexagon socket screws with a hexagon socket wrench crosswise.
- ▶ Now lead the inner part of the measuring probe into the measuring probe without tilting it. Press the locking bolt against the spring so that the inner part is pressed against the measuring cell with sufficient spring force.
- ▶ Then connect the cables as shown:

Terminal	Color	Description	Polarity	Unit
1	White/brown	Signal cable, measuring cell	-	mV
2	Brown	Signal cable, measuring cell	+	mV
3	Green	Thermoelement	+	mV
4	White	Thermoelement	-	mV
6	Black	Measuring probe heater		
7	Blue	Measuring probe heater		
8	Green/yellow	Protective conductor heating		
9	Black	Solenoid valve (optional)		
10	Black	Solenoid valve (optional)		

- ▶ Install the analyzer unit and let the system heat up to operating temperature. Perform a two-point adjustment after 24 hours of operation.

8.6.5 Replacing the inner part of the analyzer unit

Perform replacement as described in Chapter “Replacing the O₂measuring cell” to remove the inner part of the measuring probe. An exception is the thermoelement replacement, as the inner part of the measuring probe does not have to be removed here.

8.6.6 Visual check of the flameproof enclosure

Check the flameproof enclosure is ensured:

- ▶ If the enclosure is damaged, have the enclosure and enclosure cover replaced by SICK AG.
- ▶ Check all threads for damage.
- ▶ Do not paint or varnish the threads.
- ▶ If the threads are damaged, have the enclosure and enclosure cover replaced by SICK AG.
- ▶ If the protective grease on the threads has become old, remove the protective grease and grease with new suitable protective grease.
- ▶ Enclosures with protection class IP66 have seals in the flameproof joint.
- ▶ Make sure all seals are clean, undamaged and correctly installed.

8.6.7 Stability criteria during adjustment

During adjustment, the cell voltage is checked for stability. This check works according to the following criteria:

The last measured value is stored temporarily. If the next value is out of tolerance, the internal timer is reset and the new value is stored temporarily. This means that if the timer has not been reset, the value is stable. This means that the last measured value after the timer (2 minutes) is used to calculate the constants or slope.

9 Status messages

9.1 Error messages

Error message	Relay contact	Analog signal output	Description
Hardware error 1-7	System error, open	2.00 mA, if not set otherwise	The error can occur at any time and signals a fault in one of the electronic components. The O ₂ measuring probe heater is switched off. Contact one of the Sick Service points if the fault cannot be rectified by switching the system off and on again.
Open circuit Thermoelement	System error, open	2.00 mA, if not set otherwise	The error can occur at any time and signals an interruption in the thermoelement circuit. The O ₂ sensor heating is switched off. It can be reset by the user when the error cause has been eliminated. Possible causes: Contact problems of the thermoelement cable on the terminal points of the control unit and/or analyzer unit, connection cable damaged or thermoelement defective.
O ₂ measuring probe temperature not reached	System error, open	2.00 mA, if not set otherwise	The error can occur during the heating process (max. 90 minutes) of the O ₂ sensor. The O ₂ sensor heating is switched off. It can be reset by the user to start a new heating attempt. Possible causes: Fuse F2 defective, contact problems of O ₂ sensor heating cable on the terminal points of the control unit and/or analyzer unit, connection cable damaged, short circuit thermoelement, reference air flow volume greater than 60 l/h, power voltage too low, flow volume too high and/or temperature in process too low, electronics error.
O ₂ measuring probe temperature too low	System error, open	2.00 mA, if not set otherwise	The error can occur during measurement operation and indicates that the O ₂ sensor temperature has dropped 20 °C (68 °F) below the setpoint temperature. The O ₂ sensor heating is switched off. It can be reset by the user to start a new heating attempt. Possible causes: Fuse F2 defective, contact problems of O ₂ sensor heating cable on the terminal points of the control unit and/or analyzer unit, connection cable damaged, short circuit thermoelement, reference air flow volume greater than 60 l/h, power voltage too low, flow volume too high and/or temperature in process too low, electronics error.
O ₂ measuring probe temperature too high	System error, open	2.00 mA, if not set otherwise	The error can occur during measurement operation and indicates that the O ₂ sensor temperature has risen 20 °C (68 °F) above the setpoint temperature. The O ₂ sensor heating is switched off. It can be reset by the user to start a new heating attempt. Possible causes: Process temperature too high, O ₂ measuring probe heater cable incorrectly connected to the control unit, electronics error.
Open circuit O ₂ sensor	System error, open	2.00 mA, if not set otherwise	The error can occur at any time and signals an interruption in the circuit of the O ₂ sensor. It can be reset by the user when the error cause has been eliminated. Possible causes: Contact problem of the O ₂ connection cable on the terminal points of the control unit and/or analyzer unit, connection cable defective, contact problem of the inner part of the measuring probe to the O ₂ sensor.
O ₂ sensor calibration failed	System error, open		O ₂ sensor adjustment failed for one of the following reasons. It can be reset by the user; all entries subordinate to this error are then also reset.
Test gas flow rate too low	System error, open		The error can only occur during an O ₂ sensor adjustment and signals an insufficient test gas flow during the adjustment. It can be reset by the user. A new successful adjustment also resets the error. Possible causes: Test gas cylinder empty, test gas flow volume incorrectly set, test air flow volume incorrectly set, instrument air supply to the system not available.

Error message	Relay contact	Analog signal output	Description
Test gas flow rate too high	System error, open		The error can only occur during an O ₂ sensor adjustment and signals an insufficient test gas flow during the adjustment. It can be reset by the user. A new successful adjustment also resets the error. Possible causes: Test gas pressure too high, test gas flow volume incorrectly set, test air flow volume incorrectly set
O ₂ sensor offset too low	System error, open		The error can only occur during an O ₂ sensor adjustment. It can be reset by the user. A new successful adjustment also resets the error. Possible causes: Reference air supply insufficient, process pressure too high, wrong test gas (not with test air), O ₂ sensor defective.
O ₂ sensor offset too high	System error, open		The error can only occur during an O ₂ sensor adjustment. It can be reset by the user. A new successful adjustment also resets the error. Possible causes: Wrong test gas (not with test air), test gas flow volume too low, O ₂ sensor defective
O ₂ sensor slope too low	System error, open		The error can only occur during an O ₂ sensor adjustment. It can be reset by the user. A new successful adjustment also resets the error. Possible causes: Wrong test gas, test gas flow volume too low, filter damager, filter head not fitted, O ₂ sensor defective.
O ₂ sensor slope too high	System error, open		The error can only occur during an O ₂ sensor adjustment. It can be reset by the user. A new successful adjustment also resets the error. Possible causes: Wrong test gas, O ₂ sensor defective.
O ₂ sensor signal instable	System error, open		The error can only occur during an O ₂ sensor adjustment. It can be reset by the user. A new successful adjustment also resets the error. Possible causes: Test gas flow volume too low, filter damaged, process pressure fluctuations too high.
mA input for process pressure	System error, open		Circuit open or pressure transmitter signal Lower than 3.6 mA / higher than 20.4 mA
Error REMOTE module	System error, open		Signals a hardware error of the REMOTE module. Possible cause: The REMOTE module is defective.

Error messages not listed: The fault cannot be rectified by the customer. Contact one of the SICK service points.

9.2 Alarm messages

Error message	Relay contact	Description
Reference air flow too low		Possible causes: Reference air flow rate incorrectly set, instrument air supply to the system insufficient, reference air pump defective.
Reference air flow too high		Possible cause: Reference air flow rate incorrectly set.
Limit alarm 1	O ₂ limit value alarm 1, open	Possible cause: The O ₂ measured value underflows/overflows the specified O ₂ alarm limit.
Limit alarm 2	O ₂ limit value alarm 2, open	Possible cause: The O ₂ measured value underflows/overflows the specified O ₂ alarm limit.
Electronic temp. too low		Possible cause: The ambient temperature of the control unit falls below the specified lower limit. The measured value tolerances specified for the system are no longer guaranteed.
Electronic temp. too high		Possible cause: The ambient temperature of the control unit falls below the specified lower limit. The measured value tolerances specified for the system are no longer guaranteed.
Clock battery low		This cannot be reset by the user; it is only reset automatically after the watch battery (lithium cell 2032) has been replaced. The alarm has no effect as long as the system is supplied with power voltage. The set time/date can be incorrect after switching the system off and on again. Any timer-controlled automatic adjustment that may have been set can then no longer be carried out correctly. The battery may only be replaced by SICK.

Alarm messages not listed: Contact one of the SICK service points.

9.3 Maintenance messages

Maintenance message:	Relay contact	Description
Measured value(s) held	Maintenance, closed	When the measured value memory is switched on, the O ₂ measured value determined before an adjustment is held at the mA output for the duration of the status message.

10 Heating shutdown in case of malfunction

10.1 General information

The temperature of the measuring probe is monitored by an additional electronic system (Part No. 2105158) with two thermoelements. The electronics are designed to be fail-safe (redundant). They automatically switch off the measuring probe heater when the operating temperature of the measuring probe is exceeded. The switch-off temperature is 810 °C. In addition, the heating is switched off in the event of a fault in one of the thermoelements. The electronics go into self-holding mode, which means that if a fault occurs, the electronics must be reset.

The error-free operating status is indicated by two green LEDs (see “Display and operating elements”, page 81). The error case is indicated by three red LEDs.

In case of an error, the device must be reset manually. The position of the Reset button is shown in the Figure, see “Display and operating elements”, page 81.

The reset can also be initiated by switching the power supply off and on again for at least 5 seconds.

Fig. 34: Display and operating elements

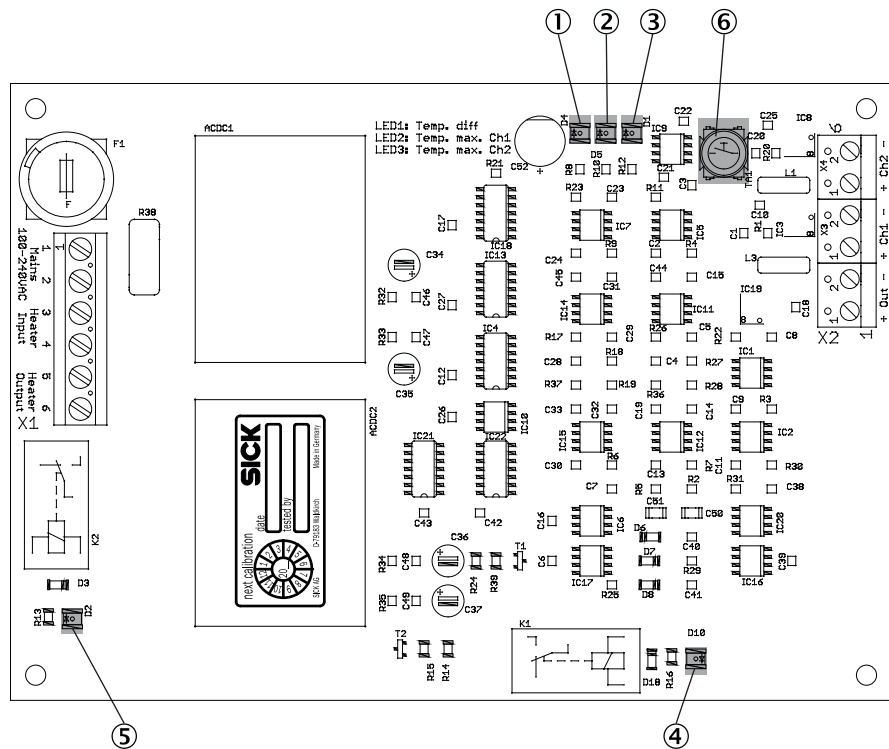

No.	Designation	Color	Description
1	LED 1	Red	Fault, temperature difference
2	LED 2	Red	Fault, temperature maximum channel 1
3	LED 3	Red	Fault, temperature maximum channel 2
4	LED 4	Green	Operation, channel 1
5	LED 5	Green	Operation, channel 2
6	Reset		

10.2 Functional description

The fail-safe heating shutdown can be used to switch the heating off when the limit temperature of heaters is exceeded, especially for ATEX-certified O₂ analyzer units.

The heating shutdown is permanently set to the temperature specified in the order code (standard is 810 °C).

The temperature is measured by means of two type K thermocouples housed in a sheathed thermoelement. The device has two independent channels. Each of these channels switches a relay when the specified maximum temperature is reached.

The contacts of both relays are connected in series so that the heating is switched off when the temperature in one channel is exceeded. The heating is also switched off when the supply voltage is lost. Furthermore, the difference between the two channels is monitored; the heating is switched off when the difference is more than 32 °C.

10.3 Maintenance

The heating monitoring is checked by the manufacturer before delivery.

The heating monitoring device must be returned to SICK for inspection at the latest by the date noted on the calibration label (see [“Display and operating elements”](#), page 81).

11 Troubleshooting

11.1 Strongly fluctuating O₂ measured value

Possible cause	Notes
Loose contact due to wire breakage of the measuring signal wire	Remove loose contact.
Loose contact in the analyzer electronics (internal mV tap)	
Broken filter element	Visual inspection by removing the analyzer unit.
Incorrectly installed V-shield	
Analyzer unit was installed without filter head	

11.2 O₂ display remains at end of measuring range or is higher than expected

Possible cause	Notes
Leakage on the measuring cell or measuring cell flange seal.	Check all flanges and screw fittings for leaks. Replace the measuring cell or renew the measuring cell flange seal. If there is a leak in the area of the O ₂ measuring cell, it must be replaced.
Analyzer unit flange leaking.	Tighten the flange screws to the required torque.

11.3 Indications on the display are OK, mA output signal is not correct

Possible cause	Notes
Control unit is defective - mA value not available	Check measuring range. Check whether the current value is outside the measuring range.
	Measure the mA output on the terminal strip PWRB.X5:17 A/B.

11.4 O₂ display on 0%, although the operating mode indicates a higher O₂ value

Possible cause	Notes
Measuring probe heater defective (resistance must be approx. 37.5...47.5 Ohm; disconnect on the analyzer unit and check) Attention: Disconnect the analyzer unit from the power supply beforehand	Query the measuring cell temperature (setpoint 800 °C or 840 °C depending on the setting). A cell temperature lower than 800 °C or 840 °C can cause a display of 0%.
Thermoelement defective (check resistance, approx. 2...80 Ohm)	Replace the inner part of the measuring probe.
Fuse of the heating voltage defective	Replace the fuse.
Transformer (230/115 V) defective	Check voltages.
Line short-circuit Electronics inlet defective Wire break	<ul style="list-style-type: none"> - Check wiring. - Measure the connection cable
mV-tap in the analyzer unit (measuring signal wire) is not available or interrupted	Check the inner part of the measuring probe for good contact.
Combustible components in flue gas	Check that the analyzer unit reacts to test gas. When the analyzer unit reacts to test gas, there may be a higher percentage of combustible gases in the flue gas. In this case, reducing conditions prevail on the O ₂ measuring cell, which reduce the O ₂ content on the cell surface.
Measuring cell defective	Replace the measuring cell.

12 Decommissioning

12.1 Safety information on decommissioning

Technical knowledge needed / requirements for decommissioning



Note:

- You are basically familiar with the ZIRKOR200 Ex-G.
- You are basically familiar with the ATEX Directive.
- You are familiar with the local situation, especially the potential hazards caused by gases in the gas duct (hot/noxious). You are capable of recognizing and preventing danger by possibly escaping gases.

If one of these requirements is not met:

- ▶ Please contact SICK Customer Service or your local representative.

Danger of explosion



DANGER:

Danger of explosion through residual voltages and hot surfaces in the device

After switching off the device, there is a danger of explosion due to the residual voltage and hot surfaces.

- ▶ Only perform work on the device in an Ex-free environment.

Gas



DANGER:

Danger to health through contaminated measuring probe

Depending on the composition of the gas in the measuring channel, the measuring probe could be contaminated with substances which could result in serious health damage.

- ▶ Wear the specified protective clothing for all work with a contaminated measuring probe.
- ▶ Decontaminate the measuring probe before storage.



WARNING:

Danger to health from contact with hot and/or aggressive measuring gases

There is a risk of contact with noxious sample gases when working on an open measuring duct.

- ▶ Observe the valid regulations concerning protective equipment during operation during all work on the device.
- ▶ Never remove the measuring probe from the duct when overpressure exists in the duct without taking appropriate safety measures.

Electricity

Observe all safety information in the Commissioning and Electrical Installation Sections:

see “[Electrical installation](#)”, page 43 and see “[Commissioning](#)”, page 56

12.2 Shutdown procedure

Carry out shutdown preparations

- ▶ Ensure the environment is Ex-free.
- ▶ Disconnect enclosure from power voltage (e.g. switch off the main switch of the host system).

After shutdown

- ▶ In potentially explosive atmospheres: Wait at least 60 minutes after disconnecting from the power voltage before opening the enclosure.
- ▶ Observe the safety information on the enclosure.

12.3 Removing the device

Material required	Part number	Required for
Flange cover	-	Covering the flange.
Personal protective equipment	-	Protection when working on the stack or hot or aggressive sample gases.

Removing the measuring system

- 1 Disconnect all cables to the power supply.
- 2 Disconnect all connecting cables between analyzer unit and control unit.
- 3 Disconnect all connecting cables between pneumatic unit and control unit.
- 4 Disconnect all cables of the customer wiring at the control unit.
- 5 Loosen the connection screws between the analyzer unit and gas channel and remove the measuring probe.
- 6 Close the flanges on the gas duct with a cover.
- 7 Loosen the connecting screws of the pneumatic unit and remove the pneumatic unit.
- 8 Loosen the connecting screws of the control unit and remove the control unit.
- 9 Pack components in containers suitable for transport.

Information on storage, see [“Storage information”, page 34.](#)

12.4 Environmentally compatible disposal

The device should be disposed as industrial waste.



Note:

Observe relevant local conditions for disposal of industrial waste.



Note:

Disposal of subassemblies containing residual substances which are harmful to the environment

The following subassemblies could contain substances that have to be disposed of separately:

- ▶ Electronics: Capacitors, rechargeable batteries, batteries
- ▶ Display: Liquid of LC display

13 Technical data

13.1 Dimension drawings

13.1.1 Dimension sheets of the control unit

Fig. 35: Zone 1 control unit dimensions (mm)

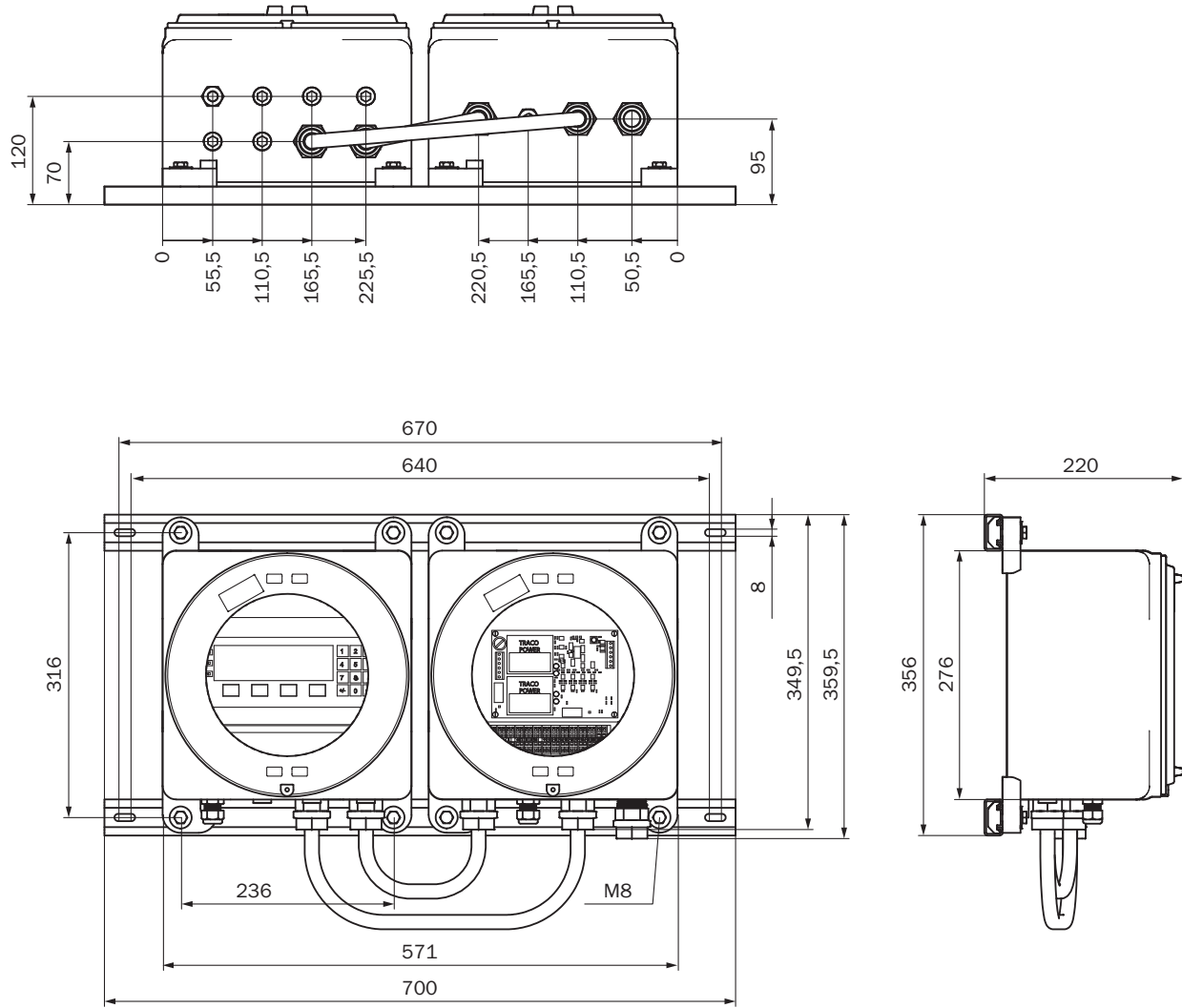

All dimensions in mm

13.1.2 Dimension sheets of the analyzer unit

Fig. 36: Dimensions of analyzer unit

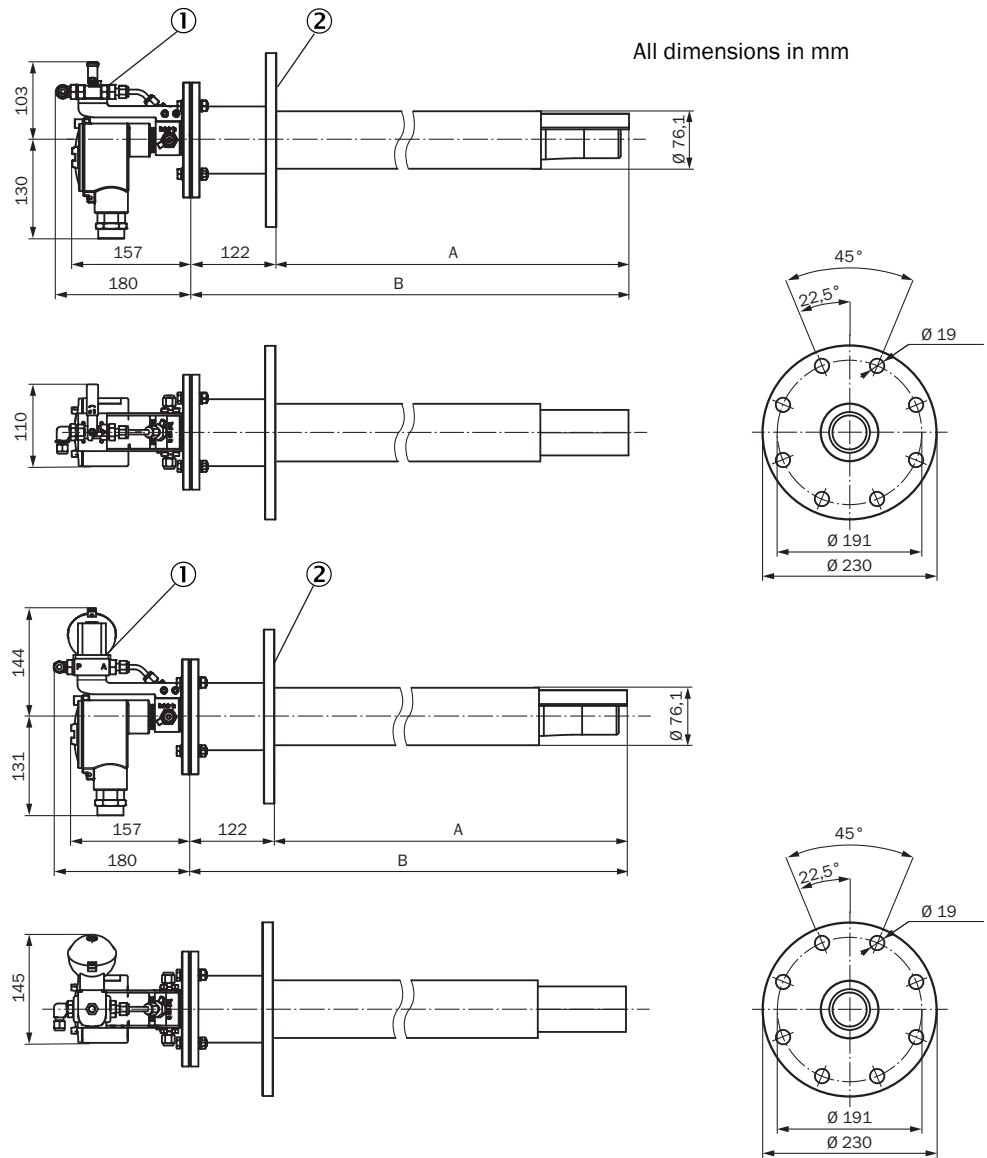

- 1 Solenoid valve/calibration gas valve: Option
- 2 Protective pipe flange

Analyzer unit type	Length A	Length B	kg*
Z200EXG-xxA	464 mm	586 mm	20,7
Z200EXG-xxB	924 mm	1046 mm	23,5

* with protection pipe and counter flange

Fig. 37: Dimensions of analyzer unit with cooling protection pipe

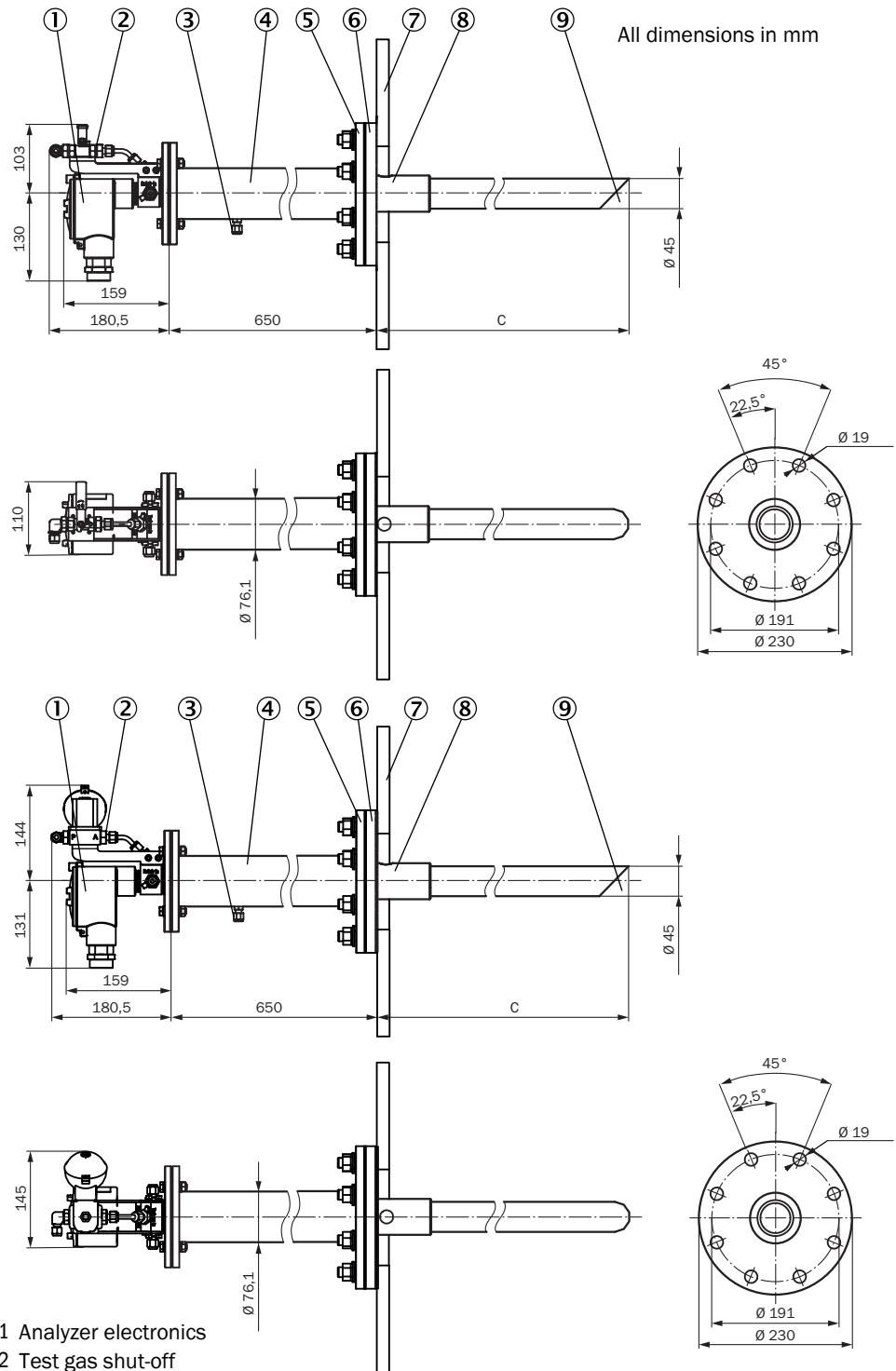

- 1 Analyzer electronics
- 2 Test gas shut-off
- 3 Suction connection 1/4"
- 4 Cooling protection pipe
- 5 Protective pipe flange
- 6 Counter flange
- 7 Duct wall
- 8 Gas outlet
- 9 Gas inlet

Cooling protection pipe	Immersion depth C	kg*
Z200EXG-xxW	500 mm	23,0
Z200EXG-xxV	1000 mm	24,1

* with measuring probe and counter flange

13.1.3 Counter flange dimensions

Fig. 38: Counter flange dimensions

Part No. 5335405

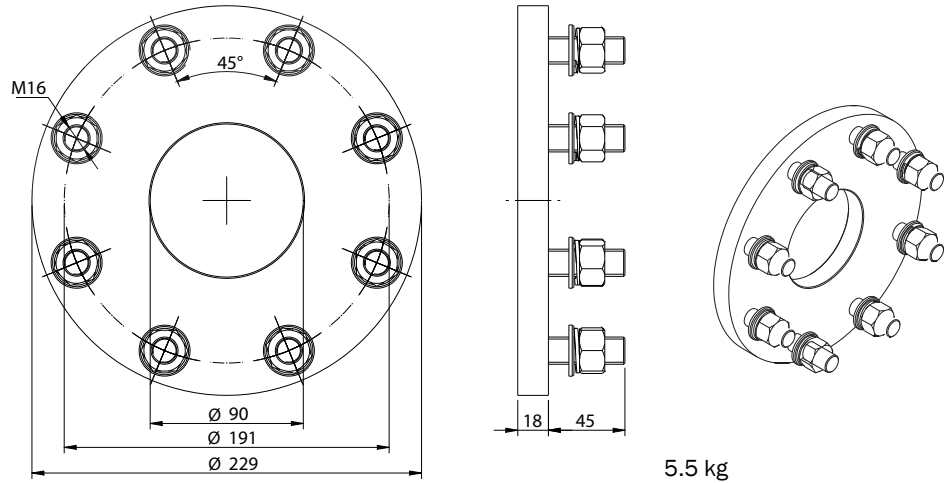

All dimensions in mm

13.1.4 Dimension of protective pipe flanges

Fig. 39: Protective pipe flanges dimensions

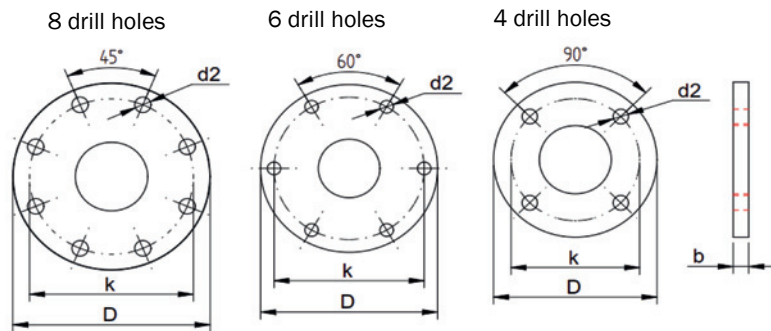

Protective pipe flange
 Mat.: DIN 1.4571 / AISI 316 Ti
 Dimensions: See Table
 Outer diameter of protective pipe: 76.1 mm

Flange type	Part No.	Ø D	b	Ø k	Ø d2	Drill holes
ANSI 4" 150 lbs	A	228.6 (9.00)	12.5 (0.50)	190.5 (7.5)	19.0 (0.75)	8
ANSI 2" 150 lbs (only with cooling protection pipe)	B	153.0 (6.0)	12.5 (0.50)	121.0 (4.75)	20.0 (0.78)	4
ANSI 3" 150 lbs	C	190.5 (7.5)	23.9 (0.94)	152.4 (6.00)	19.1 (0.75)	4
ANSI 3" 300 lbs	D	209.5 (8.25)	28.6 (1.13)	168.3 (6.63)	22.2 (0.87)	8
ANSI 4" 150 lbs	E	228.6 (9.0)	23.9 (0.94)	190.5 (7.50)	19.1 (0.75)	8

Flange type	Part No.	Ø D	b	Ø k	Ø d2	Drill holes
ANSI 4" 300 lbs	F	254.0 (10)	31.7 (1.25)	200.1 (7.88)	22.2 (0.87)	8
DN50/ PN16DIN2527 (only with cooling protec- tion pipe)	G	165.0 (6.47)	18.0 (0.71)	125.0 (4.90)	18.0 (0.71)	4
DN65/ DIN2527 (only with cooling protec- tion pipe)	H	160.0 (6.27)	14.0 (0.55)	130.0 (5.12)	14.0 (0.55)	4
DN65/ DIN2527 (only with cooling protec- tion pipe)	I	185.0 (7.28)	18.0 (0.71)	145.0 (5.71)	18.0 (0.71)	4
DN80 PN6	K	190.0 (7.48)	18.0 (0.71)	150.0 (5.91)	18.0 (0.71)	4
DN80/PN16 DIN2527	L	200.0 (7.87)	20.0 (0.79)	160.0 (6.29)	18.0 (0.71)	8
DN100/ PN16	M	220.0 (8.66)	20.0 (0.79)	180.0 (7.09)	18.0 (0.71)	8
Electronics only	Z					

All dimensions in mm (inch)

13.1.5 Analyzer unit components

Fig. 40: Analyzer unit components

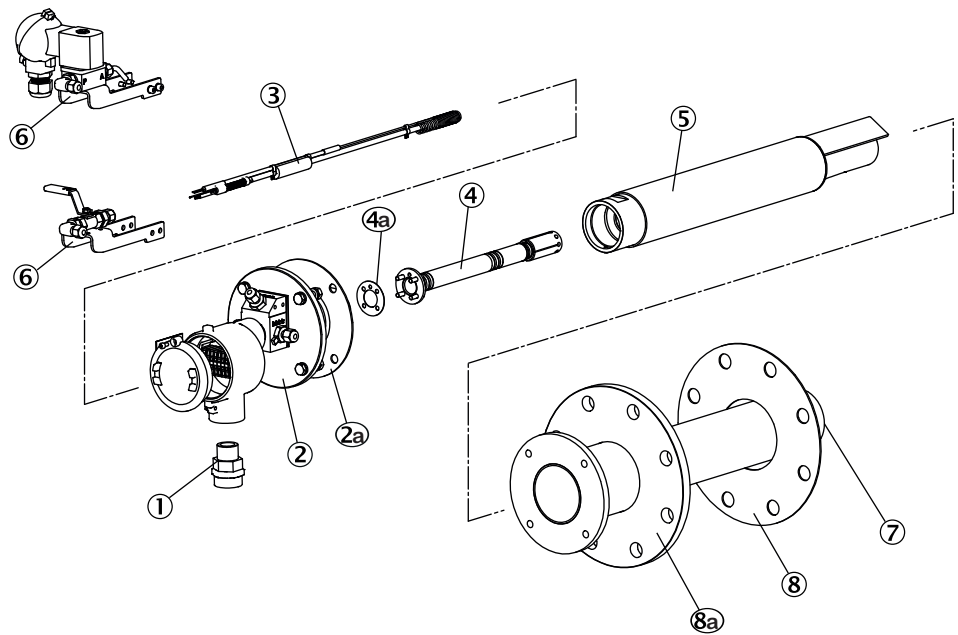

No.	Part	Part No.	Details
	O ₂ measuring probe	Z200ExG-xxA Z200ExG-xxB	A -> L= 464 mm A -> L= 924 mm
1	Cable gland	6070572 6070581	Probe cable ATEX / IECEx Reinforced probe cable ATEX / IECEx
2	Measuring probe tube	2092281	464 mm 924 mm
2a	Measuring probe flange seal	2089293	
3	Inner part of measuring probe	2105047 2105049	Probe inner part 464 mm Probe inner part 924 mm
4	Oxygen measuring cell	2105083 2105084	GasEx-ZrO ₂ sensor with seals and screws GasEx-ZrO ₂ sensor "LongLife" with seals and screws
4a	Measuring cell flange seal	2089295	
5	Filter head	2105087	
6	Test gas cock/solenoid valve	2105088 2105089	Test gas cock Solenoid valve
7	Protective pipe	Use the product code to ask your SICK contact for the part numbers.	Protective pipe length Z200ExG-XXXXY Z200ExG-XXXXX Z200ExG-xxxW Z200ExG-xxxV
8	Protective pipe flange	Use the product code to ask your SICK contact for the part numbers.	Z200ExG-XXXXA Z200ExG-XXXXB Z200ExG-XXXXC Z200ExG-XXXXD Z200ExG-XXXXE Z200ExG-XXXXF Z200ExG-XXXXG Z200ExG-XXXXH Z200ExG-XXXXI Z200ExG-XXXXK Z200ExG-XXXXL Z200ExG-XXXXM
8a	Protective pipe flange seal		Z200ExG-XXXXA Z200ExG-XXXXB Z200ExG-XXXXC Z200ExG-XXXXD Z200ExG-XXXXE Z200ExG-XXXXF Z200ExG-XXXXG Z200ExG-XXXXH Z200ExG-XXXXI Z200ExG-XXXXK Z200ExG-XXXXL Z200ExG-XXXXM

13.1.6 Dimension sheets of the pneumatic unit

Fig. 41: Dimensions and gas connections of the semi-automatic pneumatic unit

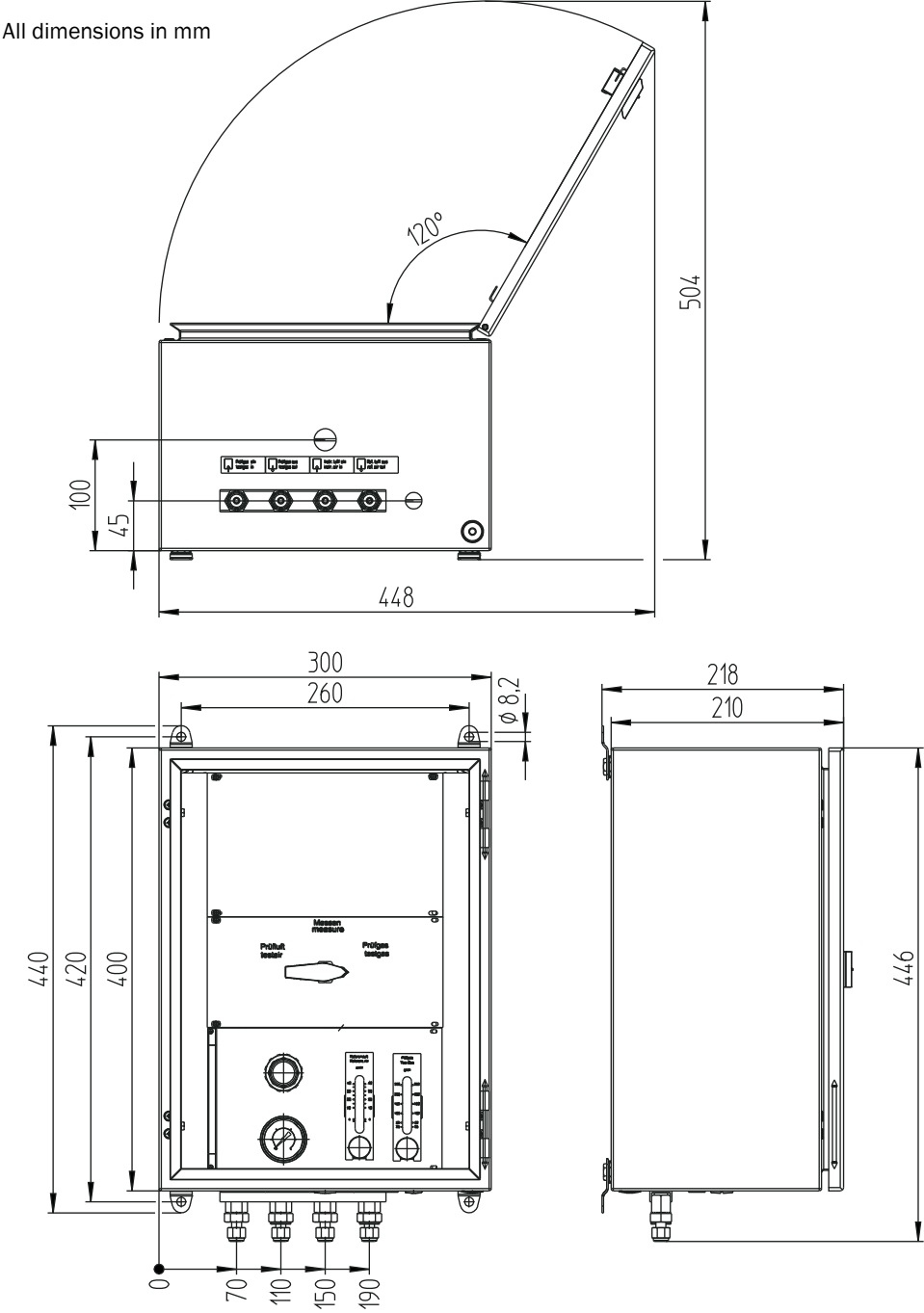

Semi-automatic adjustment

Fig. 42: Dimensions and gas connections of the fully automatic pneumatic unit

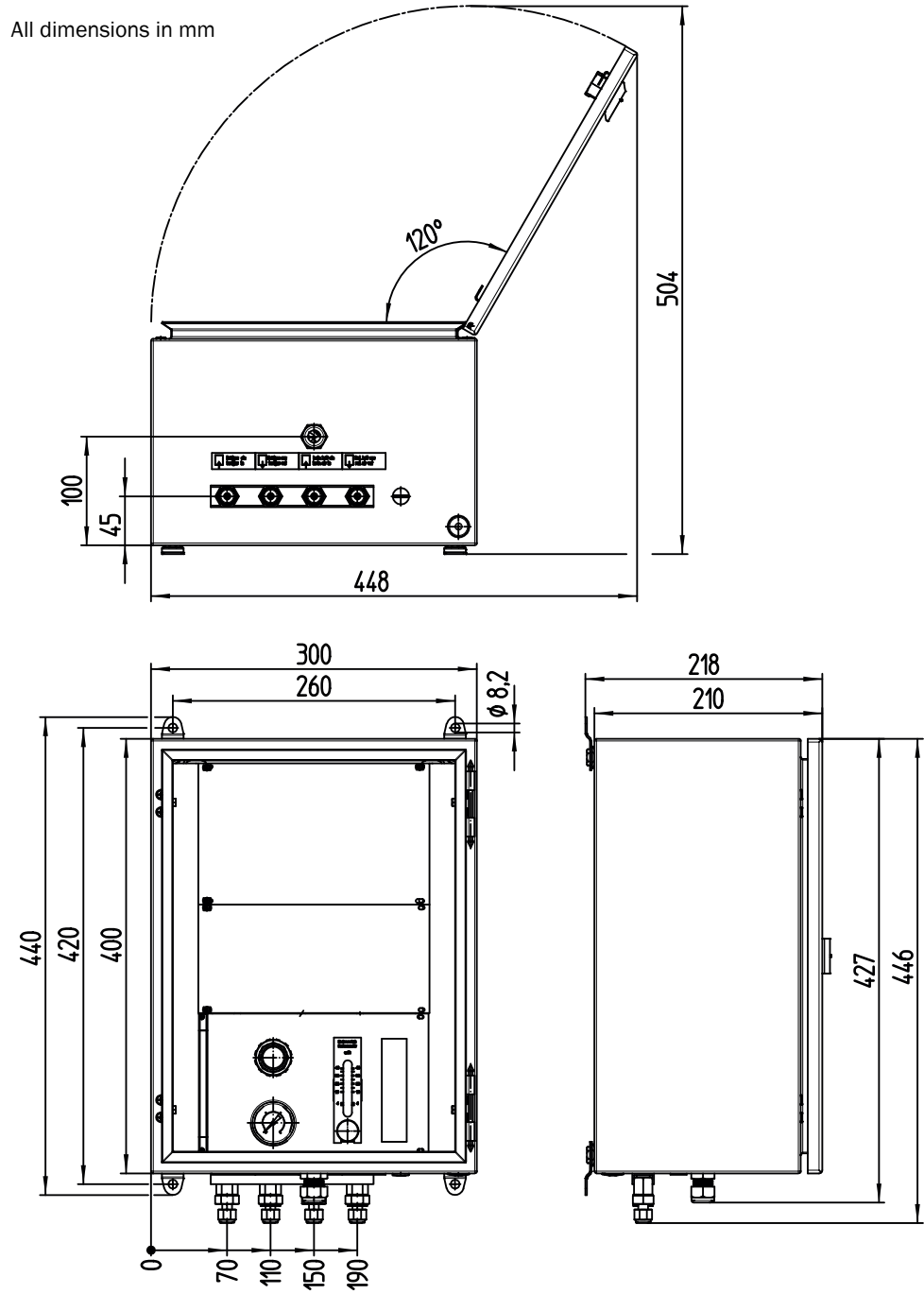

Fully automatic adjustment

13.1.7 Display board

Fig. 43: Display board

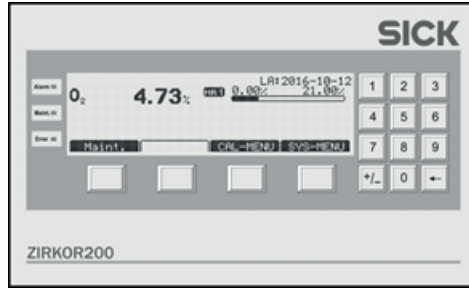

Material list: Display and control unit	
Part No.	Designation
2089320	Display board with software for systems without pneumatics
2089321	Display board with software for systems with pneumatics

13.2 Technical data

13.2.1 Installation location

The ZIRKOR200 Ex-G can be used indoors and outdoors.

Elevation: Up to 2000 m above sea level

Max. air humidity: 100% r.h., non-condensing

13.2.2 Technical data of the control unit

Housing:	Cast aluminium with viewing window
Ignition protection type:	ATEX:  II 2G Ex db IIC T6 Gb IECEX: Ex db IIC T6 Gb
Protection class:	IP 66
Certificate number:	BVS 19 ATEX E 002 X IECEX FTZU 19.0004X
Display:	LC Dot Matrix 240 x 64 LED backlit
Keypad:	Foil keyboard with pressure point
Signal LED:	Alarm, maintenance, error
Measuring ranges:	0.00 to 2.00 Vol.% O ₂ 0.00 to 25.00 Vol.% O ₂
Accuracy:	<0.5% of the measured value or 0.02 Vol% O ₂ (higher value valid)
Power voltage:	230 V ±10% 50 to 60 Hz 115 V ±10% 50 to 60 Hz
Power input:	400 VA (heating up phase) 200 VA (typ., measuring mode)
Recommended back-up fuse:	10 A
Output signal O₂:	Active, 0/4 to 20 mA, max. load resistance 500 Ω Galvanically isolated
Relay contacts:	24 V AC/DC, 1 A
Relay contact probe solenoid valve:	230 V AC/DC, 1 A
Dimensions:	700 x 356 x 200 mm (W x H x D)
Weight:	Approx. 32 kg
Temperature range, storage:	-40 °C to +80 °C
Temperature range, operation	-20 °C to +55 °C

13.2.3 Technical data of the analyzer unit

Ignition protection type:	ATEX:  II 2G Ex db IIC T3 Gb IECEX: Ex db IIC T3 Gb
Protection class:	IP 66
Certificate number:	BVS 19 ATEX E 003 X IECEX FTZU 19.0005X
Process gas temperature:	Analyzer unit ≤ 500 °C/932 °F Analyzer unit with cooling protective pipe ≤1400 °C/2552 °F
Immersion depth:	Measuring probe 464 mm / 924 mm
Immersion depth with cooling protection pipe:	Measuring probe with cooling protective pipe 500 mm / 1000 mm
Measuring principle:	Zirconium oxide
Process gas pressure:	-50 to +50 mbar
Flow velocity:	0 to 10 m/s, others on request
Ambient temperature:	-20 °C to +55 °C (-4 °F to +131 °F)
Reaction time (O ₂):	< 1 s (test gas)
T90 (O ₂):	< 5 s (test gas)
Probe material:	Stainless steel (SS316)
Voltage supply:	Via control unit

13.2.4 Data of the external pneumatics

Ambient temperature:	-20 °C to +55 °C
Voltage supply solenoid valve of control unit:	115 V AC
Cable gland for option solenoid valve:	M16x1.5
Pneumatic connections:	6x1 mm (4 pcs.; test gas inlet/outlet, reference air inlet/outlet)
Instrument air inlet:	3 to 10 bar
Test gas inlet:	Max. 3 bar
Flow volume of instrument air or test gas:	Max. 190 l/h
Protection class, field housing:	IP66

Fig. 44: Gas plan test and reference air supply unit

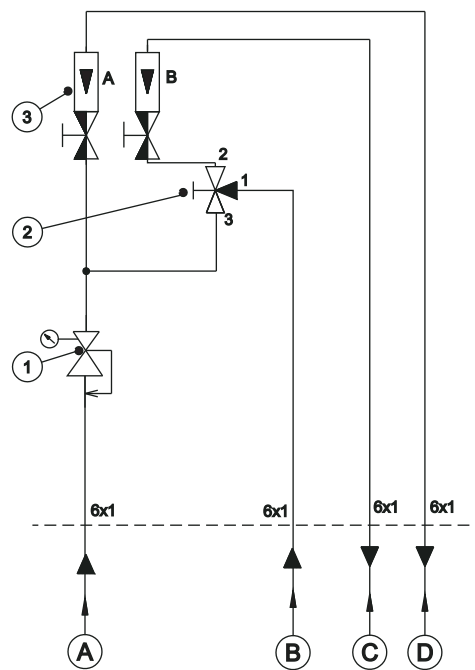

Pneumatic version for instrument air

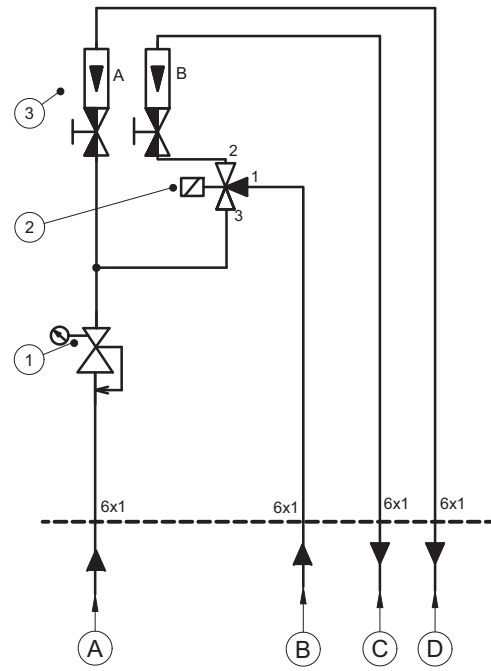

Pneumatic version with pumps

- 1 Pressure regulating valve
- 2 3/2-way ball valve
- 3 Flow meter
- A Instrument air inlet
- B Test gas inlet
- C Test gas outlet
- D Reference air outlet

- 1 Pressure regulating valve
- 2 3/2-way solenoid valve
- 3 Flow meter
- A Instrument air inlet
- B Test gas inlet
- C Test gas outlet
- D Reference air outlet

13.2.5 Technical specification for the gas supply

The oxygen measuring system uses the connected instrument air during the entire operating time to supply reference air and to supply test air (test gas 1) during adjustment or system test.

Instrument air as reference air supply / test air supply	
Specification:	According to ISO 8573-1 Class 2 (Particle size max. 1 µm, particle density max. 1 mg/m ³ , oil content max. 0.1 mg/m ³ , pressure dew point max. -40 °C) Constant 20.95 Vol. % O ₂
Inlet pressure	2...10 bar
Flow volume:	Continuous maximum 40 l/h (for reference air supply) 180 l/h during adjustment

Test gases (cylinder gas) for adjustment / system test	
Inlet pressure	Max. 3 bar
Specification Test gas 1 (optional):	21% O ₂ in N ₂ (synthetic air – when instrument air not available)
Specification Span gas 2:	2.1 Vol.-% O ₂ in N ₂ (accuracy +/- 2 %)
Flow volume:	Max. 180 l/h at 1.1 bar (+/- 0,1)



Note:

The flow volume of the test gases must be adjusted on the test gas cylinders themselves.



WARNING:

Disposal of subassemblies containing residual substances which are harmful to the environment

The following subassemblies could contain substances that have to be disposed of separately:

- ▶ Electronics: Capacitors, rechargeable batteries, batteries
- ▶ Display: Liquid of LC display

13.3 Tightening torques for Ex-relevant screw fittings

Connection unit / control unit	Reducer 1" to 8/4"	+1/2 turn after hand-tight
--------------------------------	--------------------	----------------------------

Australia

Phone +61 (3) 9457 0600
1800 33 48 02 – tollfree
E-Mail sales@sick.com.au

Austria

Phone +43 (0) 2236 62288-0
E-Mail office@sick.at

Belgium/Luxembourg

Phone +32 (0) 2 466 55 66
E-Mail info@sick.be

Brazil

Phone +55 11 3215-4900
E-Mail comercial@sick.com.br

Canada

Phone +1 905.771.1444
E-Mail cs.canada@sick.com

Czech Republic

Phone +420 234 719 500
E-Mail sick@sick.cz

Chile

Phone +56 (2) 2274 7430
E-Mail chile@sick.com

China

Phone +86 20 2882 3600
E-Mail info.china@sick.net.cn

Denmark

Phone +45 45 82 64 00
E-Mail sick@sick.dk

Finland

Phone +358-9-25 15 800
E-Mail sick@sick.fi

France

Phone +33 1 64 62 35 00
E-Mail info@sick.fr

Germany

Phone +49 (0) 2 11 53 010
E-Mail info@sick.de

Greece

Phone +30 210 6825100
E-Mail office@sick.com.gr

Hong Kong

Phone +852 2153 6300
E-Mail ghk@sick.com.hk

Hungary

Phone +36 1 371 2680
E-Mail ertekesites@sick.hu

India

Phone +91-22-6119 8900
E-Mail info@sick-india.com

Israel

Phone +972 97110 11
E-Mail info@sick-sensors.com

Italy

Phone +39 02 27 43 41
E-Mail info@sick.it

Japan

Phone +81 3 5309 2112
E-Mail support@sick.jp

Malaysia

Phone +603-8080 7425
E-Mail enquiry.my@sick.com

Mexico

Phone +52 (472) 748 9451
E-Mail mexico@sick.com

Netherlands

Phone +31 (0) 30 229 25 44
E-Mail info@sick.nl

New Zealand

Phone +64 9 415 0459
0800 222 278 – tollfree
E-Mail sales@sick.co.nz

Norway

Phone +47 67 81 50 00
E-Mail sick@sick.no

Poland

Phone +48 22 539 41 00
E-Mail info@sick.pl

Romania

Phone +40 356-17 11 20
E-Mail office@sick.ro

Russia

Phone +7 495 283 09 90
E-Mail info@sick.ru

Singapore

Phone +65 6744 3732
E-Mail sales.gsg@sick.com

Slovakia

Phone +421 482 901 201
E-Mail mail@sick-sk.sk

Slovenia

Phone +386 591 78849
E-Mail office@sick.si

South Africa

Phone +27 10 060 0550
E-Mail info@sickautomation.co.za

South Korea

Phone +82 2 786 6321/4
E-Mail infokorea@sick.com

Spain

Phone +34 93 480 31 00
E-Mail info@sick.es

Sweden

Phone +46 10 110 10 00
E-Mail info@sick.se

Switzerland

Phone +41 41 619 29 39
E-Mail contact@sick.ch

Taiwan

Phone +886-2-2375-6288
E-Mail sales@sick.com.tw

Thailand

Phone +66 2 645 0009
E-Mail marcom.th@sick.com

Turkey

Phone +90 (216) 528 50 00
E-Mail info@sick.com.tr

United Arab Emirates

Phone +971 (0) 4 88 65 878
E-Mail contact@sick.ae

United Kingdom

Phone +44 (0)17278 31121
E-Mail info@sick.co.uk

USA

Phone +1 800.325.7425
E-Mail info@sick.com

Vietnam

Phone +65 6744 3732
E-Mail sales.gsg@sick.com

Detailed addresses and further locations at www.sick.com