

FGK
High-Pressure Gas and Liquid Cell

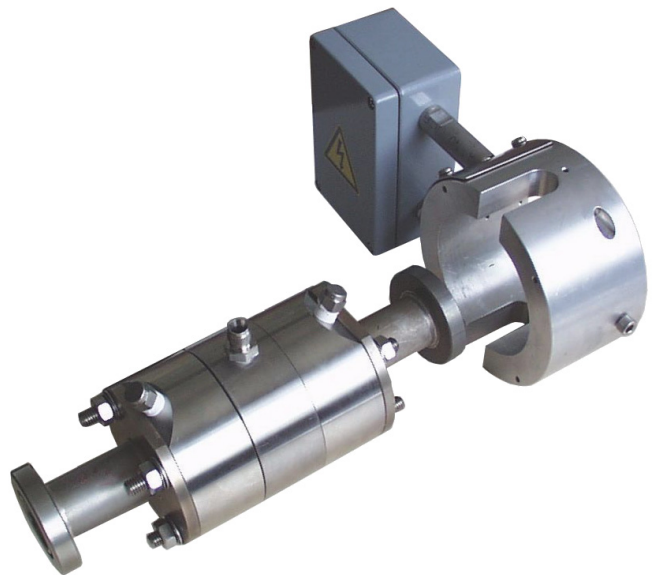

Installation
Operation
Maintenance



Document Information

Described product

Product name: FGK

Document ID

Title: Operating Instructions FGK
Part No.: 8009513
Version: 3-0
Release: 2012-07

Manufacturer

SICK AG
Erwin-Sick-Str. 1 · 79183 Waldkirch · Germany
Phone: +49 7641 469-0
Fax: +49 7641 469-1149
E-mail: info.pa@sick.de

Trademarks

Swagelok is a trademark of the Swagelok Company.

Original documents

The English edition 8009513 of this document is an original document of SICK AG.

SICK AG assumes no liability for the correctness of an unauthorized translation.









Please contact the manufacturer or your local representative in case of doubt.

Legal information

Subject to change without notice

© SICK AG. All rights reserved.

Warning symbols

	Hazard (general)
	Hazard by acidic substances
	Hazard by voltage
	Hazard in potentially explosive atmospheres
	Hazard by explosive substances/mixtures
	Hazard by noxious substances
	Hazard by toxic substances
	Hazard by high temperature or hot surface
	Hazard for the environment/nature/organic life

Warning levels / Signal words

HAZARD

Risk or hazardous situation which *will* result in severe personal injury or death.

WARNING

Risk or hazardous situation which *could* result in severe personal injury or death.







CAUTION

Hazard or unsafe practice which *could* result in personal injury or property damage.

NOTICE

Hazard which *could* result in property damage.

Information Symbols

	Information on the nature of the product with regard to Explosion Protection Directive ATEX 94/9/EC
	Important technical information for this product
	Important information on electric or electronic functions
	Nice to know
	Supplementary information
	Link to information at another place

1	Important Information	7
1.1	Main hazards	8
1.2	Intended use	8
1.2.1	Purpose of the cell	8
1.2.2	Limitations	8
1.3	Responsibility of user	9
2	Product Description	11
2.1	Product identification	12
2.2	FGK cell description	12
2.3	Materials used	13
2.3.1	Thermostatic control	13
3	Installation	15
3.1	Pressure test	16
3.2	Installation	16
3.2.1	Connecting the measured medium	17
3.2.1.1	Preparation work	17
3.2.1.2	Connecting the measured medium	18
3.2.1.3	Carrying out the leak test	19
3.2.2	Connecting purge gas	20
3.2.3	Electrical installation	21
3.2.3.1	Preparation work	21
3.2.3.2	Electrical connection for the heating jacket	21
4	Start-up / Operation	23
4.1	Start-up	24
4.1.1	Safety information for start-up	24
4.1.2	Start-up procedure	24
4.2	Operation	25
5	Shutdown	27
5.1	Shutdown	28
5.2	Disposal	28
6	Maintenance	29
6.1	Maintenance plan	30
6.2	Recommended spare parts for 2 years operation	30
6.3	Removing the cell from the MCS300P	31
6.4	Working on the cell	31
6.4.1	Taking the heating jacket off	31
6.4.2	Working on the cell body	32
6.4.2.1	Removing the flanges	32
6.4.2.2	Removing the protective and cell windows and seals	32
6.4.2.3	Fitting the protective and cell windows and seals	33
6.4.2.4	Installing the flanges	34
6.5	Fitting the cell on the MCS300P	34

7	Clearing Malfunctions	35
7.1	Clearing malfunctions.....	36
7.2	Safety temperature switch has triggered	36
8	Technical Specification	37
8.1	Compliance	38
8.1.1	Electrical protection	38
8.2	Cell dimensions and Part Nos.	39
8.3	Heating jacket dimensions and Part Nos.	40
8.4	Technical data	41

FGK

1 Important Information

Main hazards
Intended use
Own responsibility

1.1 Main hazards

**CAUTION: Noxious and irritating measured media**

When the measured medium contains noxious or irritant substances:

- ▶ Operate the FGK in a safe manner (→ p. 24, §4.1.1)

**WARNING: Explosion hazard in potentially explosive atmospheres**

- ▶ Do not use the FGK in potentially explosive atmospheres.

**WARNING: Hazards by ignitable measured media**

- ▶ Do not use the FGK for measuring ignitable measured media.

1.2 Intended use

1.2.1 Purpose of the cell

The FGK cell is part of a measuring system suitable for analyzing gases and liquids.

1.2.2 Limitations

- ▶ Check whether the cell is suitable for the planned measured medium.
 - List with materials used in the cell: Refer to the Data Sheet delivered with the cell.
 - In case of doubt, contact your local SICK Sales Office.

1.3

Responsibility of user

Intended user

The FGK cell may only be installed by skilled persons who, based on their technical training and knowledge as well as knowledge of the relevant regulations, can assess the tasks given and recognize the dangers involved.

Correct use

- ▶ Use the cell only as described in these Operating Instructions.
The manufacturer bears no responsibility for any other use.
- ▶ Have the prescribed maintenance work performed.
- ▶ Do not remove, add or modify any components in or on the cell. Otherwise:
 - The cell can become dangerous.
 - Any warranty by the manufacturer becomes void.

Special local conditions

- ▶ In addition to these Operating Instructions, follow all local laws, technical rules and company-internal operating directives applicable at the respective installation location of the device.

Further documents

- MCS300P Operating Instructions (for assembling the cell on an MCS300P).

Retention of documents

These Operating Instructions:

- ▶ Must be available for reference.
- ▶ Must be passed on to new owners.

FGK

2 Product Description

Product identification
Functional principle

2.1 Product identification

Manufacturer:	SICK AG · Dr.-Zimmermann-Str. 18 D-88709 Meersburg · Germany	
Cell with heating jacket	Optical path length	Part No.
FGK01	< 14 mm	2024595
FGK15	15 .. 39 mm	2024596
FGK40	40 .. 99 mm	2024597

The type plate is located on the connection box (→ p. 21, Fig. 8).

2.2 FGK cell description

The measured medium is channeled through a sample compartment limited by windows on the side.

The measuring beam of a connected analyzer travels lengthwise through the cell and through the sample compartment. The measuring beam is attenuated by the measured medium, depending on the medium, and the analyzer evaluates this attenuation.

The optical path length of the sample compartment is preset with an intermediate ring.

Protective windows between the sample compartment windows and the flanges to the analyzer form a purge gas compartment. This can be purged via purge gas connections. This allows, for example, flushing out gas escaping in the cell windows and detecting such leaks.

Fig. 1 FGK view (without heating jacket)

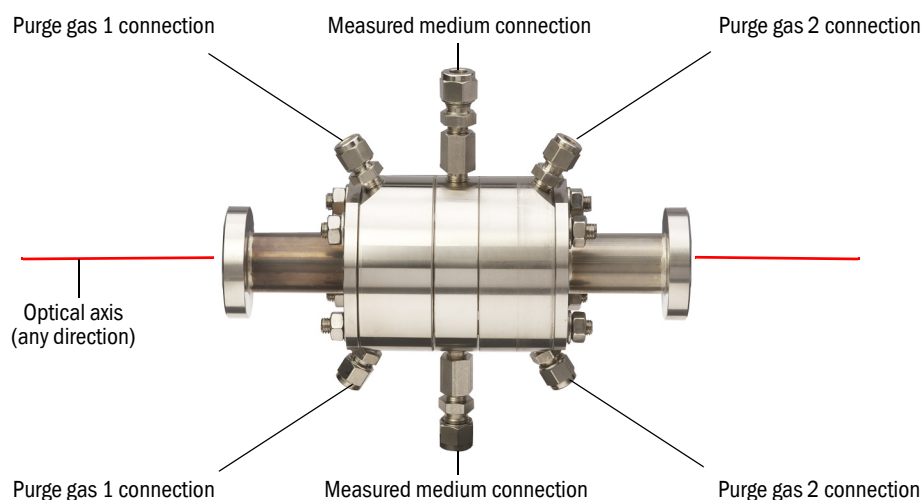

WARNING: Risk of burns by hot measured medium

The cell is hot when the measured medium is hot.

► Do not touch the cell.

2.3

Materials used

Different materials are used for the windows and seals depending on the spectral range and application conditions.

- The cell is suitable for reactive and corrosive media depending on the materials used.
- The maximum operating pressure depends on the materials used.



▶ Refer to the Data Sheet delivered with the cell for the materials used.

2.3.1

Thermostatic control

Fig. 2

Heating jacket

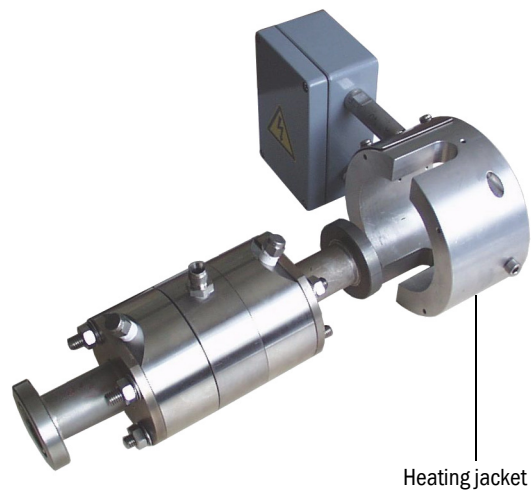

The cell has a heating jacket.

A Pt100 sensor is fitted for measuring the temperature.

An external “temperature controller for Pt100 sensors” controls the temperature (not part of the cell).

For thermal protection, the cell is equipped with a self-resetting temperature switch (→ p. 36, § 7.2 and → “Technical data”).

FGK

3 Installation

Installation
Initial start-up

3.1 Pressure test

**WARNING: Risk of bursting through improper use**

The maximum cell working pressure depends on the materials used (windows, seals) and the cell working temperature.

- ▶ Observe the specifications in the Technical data (→ p. 41, §8.4).

3.2 Installation

The FGK is normally installed on a SICK MCS300P analyzer.

The location of the sample gas beam inlet and outlet is arbitrary.

Fig. 3

FGK cell on MCS300P

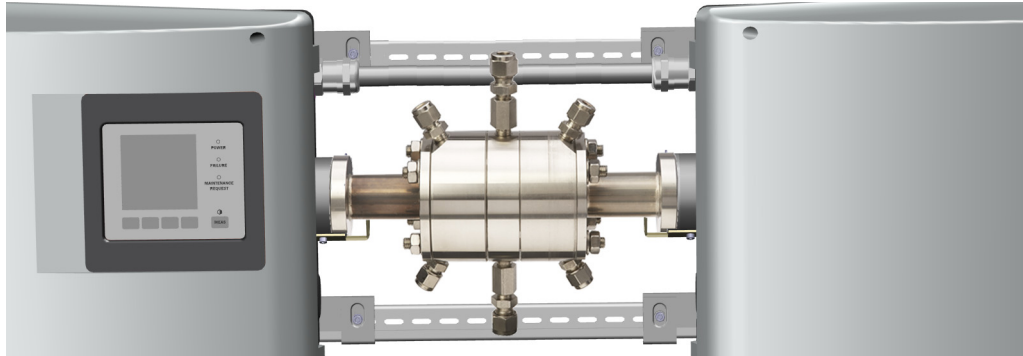

If you wish to install the cell yourself: → MCS300P Operating Instructions.

Final installation steps:

- 1 Connect measured medium → p. 17, §3.2.1.
- 2 Connect purge gas (optional) → p. 20, §3.2.2.
- 3 Electrical installation (when using the heating jacket) → p. 21, §3.2.3.

3.2.1 Connecting the measured medium

Connections may only be performed by skilled persons who, based on their technical training and knowledge:

- Are familiar with handling tubes and tube screw fittings.
- Are capable of performing suitable leak tightness tests.

**CAUTION: Damage through condensate**

Condensate can form on the sample gas outlet when using moist and hot sample gas.

- ▶ Keep the line opening free from any blockages.
- ▶ Always lay the line so that it runs downwards and no condensate can be formed.
- ▶ If necessary, provide for a suitable condensate collecting device and adequate ventilation.
Check and empty the condensate collection container regularly.

**CAUTION: Damage resulting from overpressure**

Blocked tubes can falsify measured values and possibly damage the cell.

- ▶ The measured medium outlet may not increase the working pressure.
- ▶ Only use tubes and screw connections that are adequate for the required pressure.
- ▶ Do not bend or crimp the tubes.

3.2.1.1 Preparation work

**WARNING: Danger to life/health risk by noxious media**

If noxious measured media are passed to the cell, escaping measured medium can damage health.

- ▶ Lay cell outlets into the open or into a suitable collective duct.
 - ▶ Pay attention to the information from the equipment operator.
- A leak in the measured medium path can create acute danger for persons.
- ▶ Take suitable safety measures.

**CAUTION: Possibly provide initial thermal stabilization for cold measured medium.**

When cold sample gas is fed to a heated cell, it is possible that the measurement signal becomes unstable due to thermal turbulence.

- ▶ Plan suitable initial thermal stabilization when necessary.

3.2.1.2 Connecting the measured medium

Fig. 4 Measured medium connection

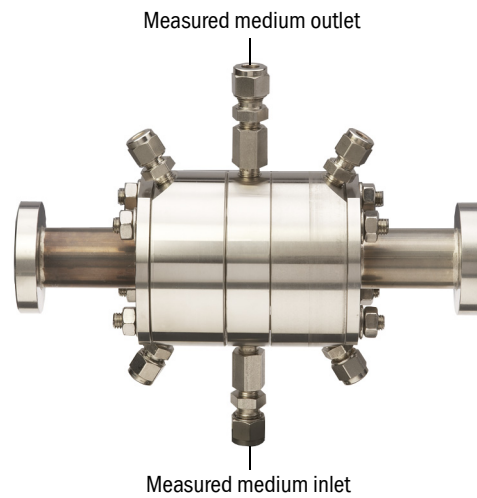

- ▶ Connect tubes leak-proof.
 - *Vertical assembly (recommended):* Inlet down, outlet up (recommended).
- Note:* Only use tubes suitable for the measured medium.
Information on plastic tubes: Use support sleeves.

Fig. 5 Clamping ring screw connection

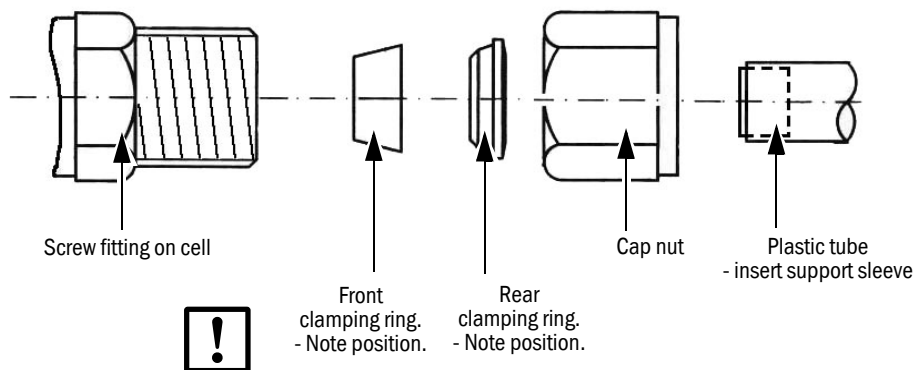

- 4 Perform leak tightness check (→ p. 19, §3.2.1.3).

3.2.1.3 Carrying out the leak test

Fig. 6 Leak test arrangement

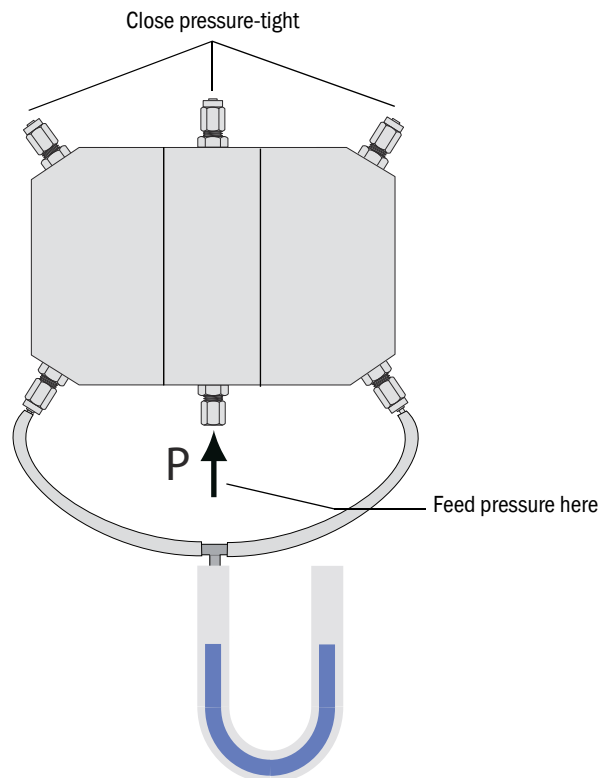
**WARNING: Risk of bursting with high pressure**

Glass splinters can escape from the tubes should a window break.

- ▶ Bring the cell to a safe place and cover the tubes.
- ▶ Observe the pressure test information (→ p. 16, §3.1).

- 1 Bring the cell up to operating temperature.
- 2 Slowly apply 1.5 times the operating pressure to the cell sample compartment.
- 3 Use a transparent plastic hose with 400 mm water column to monitor leak tightness.
1 mm water column corresponds to 0.1 mbar.
The water column must not change as the pressure is increased resp. within 1 minute.

3.2.2 Connecting purge gas

Fig. 7

Purge gas connections

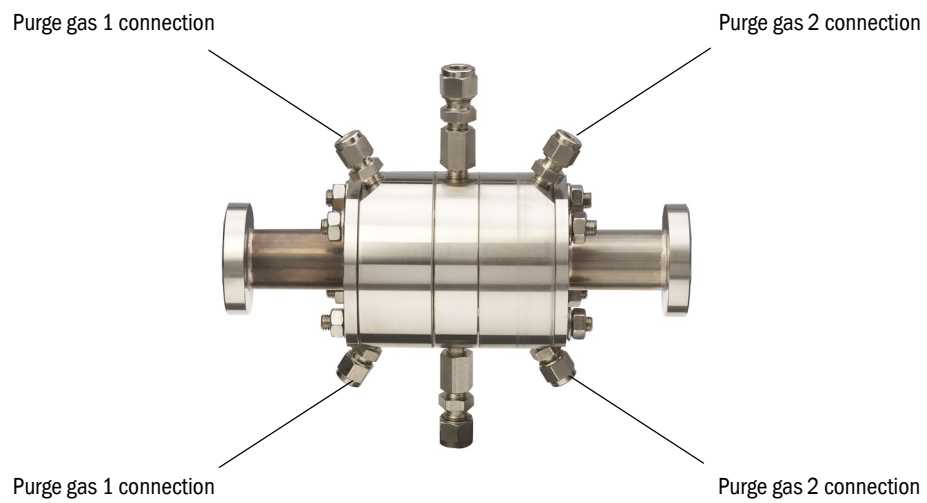

- Feeding into the purging compartments must run via a return valve (provided by operator).
- Purge gas disposal must be made against atmospheric pressure and using lines with a larger cross-section than those for the purge gas to the cell.
- The operator must ensure purge gas pressure and purge gas flow.
- The measured medium may only be fed into the cell when the purge gas flow is available.
- The operator must ensure safe disposal of the purge gas as well as any sample gas escaping after a malfunction.

Procedure

- ▶ Connect purge gas lines.

3.2.3 Electrical installation

Electrical installation is required only when the cell is to be heated.



WARNING: Hazard by voltage

The FGK may only be installed by skilled persons who, based on their technical training and knowledge as well as knowledge of the relevant regulations, can assess the tasks given and recognize the dangers involved.

3.2.3.1 Preparation work

- Install a suitable mains disconnecting device to be able to disconnect the device from the mains and make all poles potential-free.
- Install a suitable mains fuse for the cell heater.
 - 4 A (for 115 V and 230 V)
- Install an external temperature controller for Pt100 sensors (when desired)

3.2.3.2 Electrical connection for the heating jacket

Fig. 8 Connection box

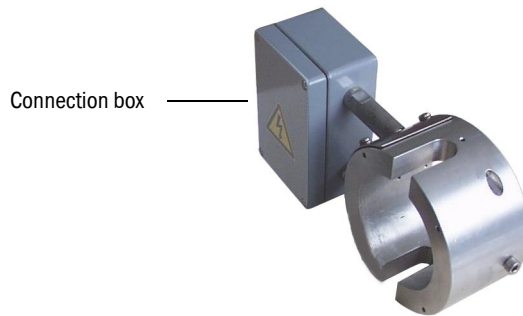

- 1 Loosen 4 screws on the connection box cover.
- 2 Take the cover off.



A wiring diagram is in the connection box cover.

Fig. 9 Connecting diagram

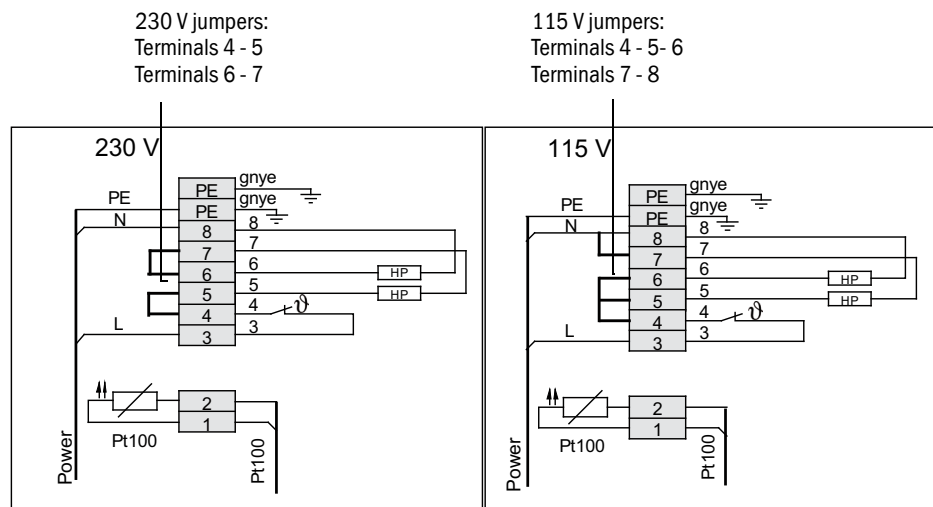

Subject to change without notice

3 Check voltage setting on jumpers

**NOTICE: Pay attention to jumpers**

- ▶ Jumpers depend on the mains voltage.

- 4 Lead connection lines for mains voltage and Pt100 (specification → “Technical data”) through the cable glands and connect in the connection box.
- 5 Screw cable glands tight.
- 6 Position the connection box cover and screw tight.
- 7 Connect the cell to the external temperature control.

FGK

4 Start-up / Operation

Start-up
Operation

4.1 Start-up

4.1.1 Safety information for start-up



WARNING: Hazards by ignitable measured media

- ▶ Do not use the FGK for measuring ignitable measured media.



WARNING: Mortal/health danger as a result of measured medium path leakage

- When noxious gases are passed to the cell:
A leak in the gas path can create an acute danger for persons.
- ▶ When required, carry out a leak test (→ p. 19, §3.2.1.3).

4.1.2 Start-up procedure

- 1 Check measured medium supply for:
 - Damage
 - Leak tightness
 - Continuity
 - Functional capability of measured media filtering
 - Correct setting for measured medium pressure
 - When heated: Functional capability of heater
- 2 Let the cell heat up.



There is a risk of condensation in the cell when gas is fed to a cold cell.

- ▶ Let the cell heat up.
- ▶ Then feed sample gas.

- a) When used under ambient temperature without heating:
 - Allow the cell to adapt to the measured medium temperature for approx. 5 h.
- b) When using the cell heating:
 - Check the setting of the temperature controller.
 Heating up time:
 - From room temperature to approx. 50 °C (120 °F): Approx. 1 hour
- 3 Set the purge gas flow rate.
 - Flow rate: Approx. 2 l/h
- 4 Feed measured medium.

When the cell is operated with pressure: Apply pressure slowly.

 - Max. pressure: → Data Sheet
 Set the measured medium flow rate:
 - Recommended flow rate:
 - For sample gas: 100 - 600 l/h
 - For measured liquid: 2 - 8 l/h
 Make sure there are no bubbles in the cell when using liquids.

4.2

Operation



WARNING: Risk of burns on hot surfaces

The cell and the connections can be very hot.

- ▶ Do not touch surfaces.

The cell operates automatically.

In regular intervals:

- ▶ Check the cell and connected tubes for:
 - Damage
 - Leak tightness
 - Continuity

FGK

5 Shutdown

Preparations
Switch-off procedure

5.1

Shutdown**WARNING: Hazard resulting from substances remaining in the cell**

Depending on the measured medium composition, toxic or corrosive gases can remain in the cell and connected tubes when the measured medium supply is switched off. If necessary:

- ▶ Purge the cell and connected tubes with inert medium for at least 1 hour.
- ▶ Take suitable protective measures (e.g. working under a vent, wearing suitable protective clothes).
- ▶ Decontaminate the cell.

- 1 Switch off the measured medium feed and ensure that no more medium can flow into the cell.
- 2 Depending on the measured medium composition, purge the cell and connected tubes with inert gas for at least 1 h.
- 3 Ensure that there is no pressure.
- 4 Switch purge gas off when used.
- 5 If the heating is connected: Switch the heating off and disconnect where necessary.
- 6 If the cell is to be put out of operation for a longer period: Close the inlets and outlets airtight.

**WARNING: Risk of burns on hot surface**

The cell and the connections can be very hot.

- ▶ Allow the cell and connections to cool down before touching.

**WARNING: Danger when storing or dispatching**

If the cell can contain deposits dangerous to health and the cell is to be stored or sent somewhere:

- ▶ Mark the cell *clearly*:
 - Which medium was in the cell.
 - Which hazards exist (e.g. when disassembling the cell).
 - How the cell was cleaned.

5.2

Disposal

- ▶ Observe local regulations.
- ▶ Dispose of electronic components (heating cartridges) as electronic waste.
- ▶ Dispose of metal parts as scrap metal.
- ▶ Dispose of windows and seals as residual waste.
- ▶ If the cell was used with toxic substances or substances harmful to the environment and there is a risk that deposits of these substances still cling to parts with media contact: Dispose of parts with media contact as hazardous waste.

FGK

6 Maintenance

Maintenance plan
Recommended spare parts

6.1 **Maintenance plan**

Maintenance interval	Maintenance work
1 year	<ul style="list-style-type: none"> ▶ Disassemble and clean the cell. Recommendation: <ul style="list-style-type: none"> ▶ Renew O-rings with media contact. ▶ Renew the cell windows (can be severely damaged during disassembly).
2 years	<ul style="list-style-type: none"> ▶ Additionally: Renew O-rings and protective windows in the purging compartment ring.

**NOTICE: Malfunction hazard**

Maintenance work on the FGK may only be carried out by skilled persons trained on the FGK.

6.2 **Recommended spare parts for 2 years operation****WARNING: Malfunction hazard**

- ▶ Use original SICK spare parts only.

**WARNING: Risk of leaks and bursting when incorrect seal or window materials are used**

The maximum operating pressure and therefore cell leak tightness depend on the window and seal materials used.

- ▶ Observe the maximum operating pressure: → p. 41, "Technical data" or Data Sheet.
- ▶ Only use window and seal materials specified in the Data Sheet.

Assembly kits ^[1]	Quantity ^[2]	Y ^[3]	2y ^[4]	Part No.
Cell-side windows and seals				
1 set Quartz windows 32 x 8 with Kalrez and Viton O-ring	2	x		2024588
1 set CaF2 windows 32 x 8 with Kalrez and Viton O-ring	2	x		2024589
Protective windows and seals, purging compartment ring				
1 set Quartz protective windows 32 x 5 with flat seal and Viton O-ring	2		x	2024591
1 set CaF2 protective windows 32 x 5 with flat seal and Viton O-ring	2		x	2024592

[1]→ p. 39, § 8.2

[2]Number of sets per maintenance

[3]Recommendation: Renew yearly

[4]Recommendation: Renew every 2 years

6.3 **Removing the cell from the MCS300P**

 [Cell disassembly from MCS300P → MCS300P Operating Instructions](#)

6.4 **Working on the cell**

6.4.1 **Taking the heating jacket off**

Fig. 10 **Loosen the heating jacket clamping screw**

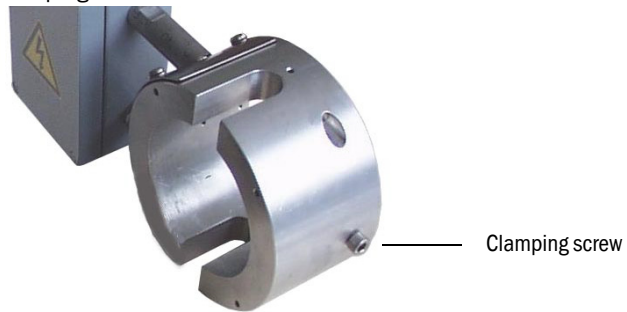

- 1 Loosen the clamping screw.
- 2 Take the heating jacket off.

6.4.2 Working on the cell body

**WARNING: Toxic and acidic deposits**

Toxic, acidic or corrosive gases or deposits can be present in parts of the cell depending on the measured medium.

- ▶ Ensure adequate ventilation.
- ▶ As necessary, take suitable protective measures (e.g work under a vent, wear breathing protection, protective goggles or safety mask, protective gloves and acid-proof protective clothes).

Fig. 11

Exploded view of the cell body (technical drawing → Technical data)

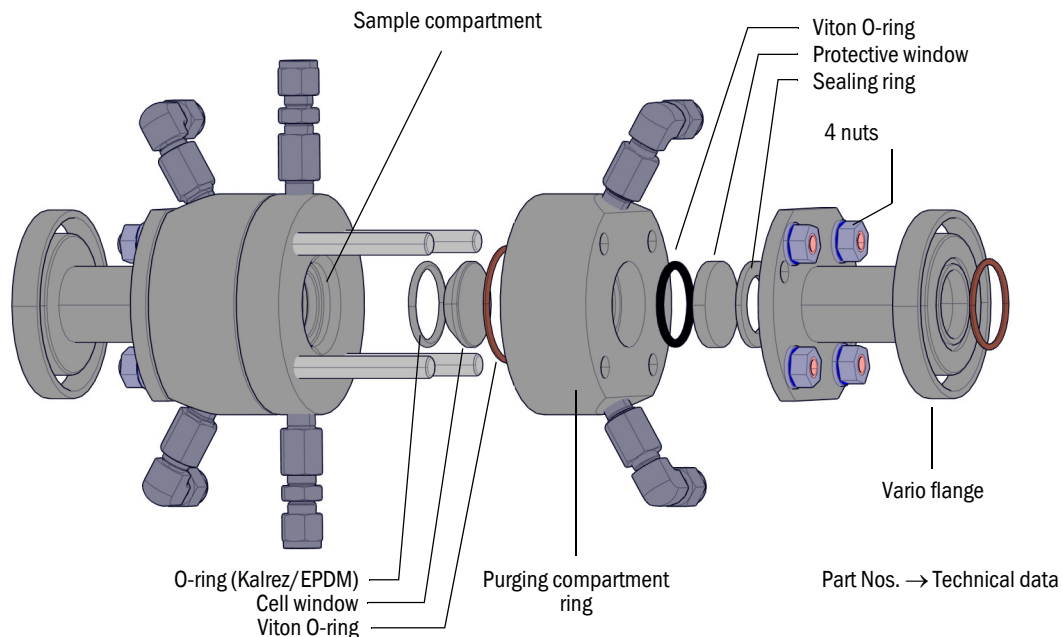

6.4.2.1

Removing the flanges**NOTICE:**

- ▶ Make sure the cell windows do not fall out during removal.
- ▶ Protect windows from contamination and damage.

- 1 Position the cell so that the flange to be disassembled points upwards.
- 2 Unscrew 4 nuts on the cell face side.
Take nuts, washers and lock washers off.
- 3 Remove the loose sealing ring.

6.4.2.2

Removing the protective and cell windows and seals

- 1 Pull the protective windows out with a suction cap (windows can stick).
Lay the windows in a clean, secure place.
- 2 Take the loose O-ring out.
- 3 Pull the purging compartment ring off straight upwards.
- 4 Take the loose O-ring out.

**NOTICE:**

- ▶ Do not touch the cell windows with your fingers (wear gloves, if required) and do not contaminate the windows.

- 5 Take the cell windows out.
Lay the windows in a clean, secure place.
- 6 Take the loose O-ring out.

6.4.2.3 Fitting the protective and cell windows and seals

- 1 Carefully clean the sealing surfaces.
 - If necessary, use cotton swabs or wooden sticks for cleaning, and possibly acetone.
 - Use new O-rings.
Make sure that the O-rings are made of the correct material.
Do not mix up the O-rings.
- 2 Carefully insert a new O-ring in the sample compartment groove.



WARNING: Risk of bursting with scratched windows and high pressure

Windows can burst when scratched and with high operating pressure.

- ▶ Only use windows in perfect condition.



NOTICE: Make sure that the cell is clean

Measured medium and purge gas compartments must be clean before assembly.

Cleaning agent residues could affect measurement.

The windows must be clean.

- ▶ Do not touch the windows with your fingers.

- 3 If necessary, clean the windows carefully with a soft cloth.
Suitable cleaning agent (depending on the measured medium):
 - Demineralized water
 - Isopropanol
 - Acetone

Do not use any other cleaning agents and no scouring cloths.
Carefully dry the windows after cleaning (no marks should remain).

- 4 Position the cell windows
 - With the bevel towards the O-ring
 - Centered very carefully
 - Horizontal.
- 5 Carefully insert the new O-ring on the sample compartment side of the purge gas ring.
- 6 Very carefully lower the purging compartment ring vertically from above.
 - Make sure the O-ring is seated correctly
- 7 O-ring for purging compartment ring
 - Check for damage and use a new O-ring when damaged.
 - Insert it into the groove.
- 8 Insert the protective windows.
- 9 Sealing ring for protective windows
 - Check for damage and use a new sealing ring when damaged.
 - Insert it into the groove.

6.4.2.4

Installing the flanges

- 1 Lower the cell flange vertically from above.
- 2 The 4 screws of the cell flange:
 - Tighten slightly evenly so that the cell window does not slip.
 - Then tighten evenly.
- 3 Perform a suitable leak test (→ p. 19, §3.2.1.3).

6.5

Fitting the cell on the MCS300P

The cell is normally operated on an MCS300P.

The location of the measurement beam inlet and outlet is arbitrary.

Recommendation: Fit the cell in the same direction as beforehand.



Fitting the cell on the MCS300P → MSC300P Operating Instructions.

FGK

7 Clearing Malfunctions

General malfunctions

7.1 **Clearing malfunctions**

Malfunction	Possible cause	Note
Medium flow rate too low.	Measured medium path blocked.	Clean.
Leak.	Measured medium path leaky.	Seal.
	Cell window leaky.	Clean or renew window (→ p. 31, §6.4).
Safety temperature switch has triggered.	Temperature on temperature controller set too high.	Cell seals can be damaged (→ p. 31, §6.4).
Temperature varies considerably.	Mains connection incorrect.	Provide mains connection.
	Temperature controller defective.	Have the temperature controller repaired or replaced.
Heater does not work.	No voltage supply.	Provide mains connection.
	Heating defective.	Please contact SICK Customer Service.
Condensate in the cell.	Temperature below dew point.	Check cell and clean as necessary. Check thermostatic control. Heat the sample gas feed. Dry the sample gas (e.g. gas cooler).
Not enough energy at the analyzer detector.	Cell window or mirror contaminated.	Clean cell (→ p. 31, §6.4).
Unstable measurement signal.	Temperature difference between cell and measured medium very high.	Adjust temperature.
	Cell window or mirror contaminated.	Check the cell temperature. Clean cell (→ p. 31, §6.4).
	Temperature controller hysteresis too large.	Reduce hysteresis.
Measured values incorrect.	For heated cell: Measured medium or purge gas flow rate too high so that cell cools down.	Adjust flow rate or preheat gas.
	After cleaning: Cleaner in measured medium or purge gas compartment.	Clean cell thoroughly.

7.2 **Safety temperature switch has triggered**

Cutout temperature: Approx. 75 °C.

The internal safety temperature switch switches on independently when the reset temperature is underflown (approx. 62 °C).

FGK

8 Technical Specification

Declaration of conformity

Technical data

8.1

Compliance

The technical design of this device complies with the following EU directives and EN standards:

- EU Directive: LVD (Low Voltage Directive)
- EU Directive: EMC (Electromagnetic Compatibility)

Applied EN standards:

- EN 61010-1: Safety requirements for electrical equipment for measurement, control and laboratory use
- EN 61326: Electrical equipment for measurement technology, control technology and laboratory use - EMC requirements



8.1.1

Electrical protection

- Insulation: Class of protection 1 in accordance with EN 61010-1.
- Contamination: The device operates safely in an environment up to contamination level 2 in accordance with EN 61010-1 (usual, non-conductive contamination and temporary conductivity by occasional moisture condensation).

8.2

Cell dimensions and Part Nos.

Subject to change without notice

geliefert delivered fourni	Fenster window fenêtre	Bausatz Fenster + O-Ring set window + O-ring Ensemble fenêtre + O-Ring
	Quarz	2024588
	CaF2	2024589
A	BaF2	2024586
	IG2	2024590
	Saphir	2024587
	Quarz	2024591
B	CaF2	2024592
	BaF2	2024594
	IG2	2024593

2 Stück pro Küvette erforderlich
2 pieces per cell required
2 pièces nécessaire par cellule

geliefert delivered fourni	OPTION	Spülen purging balayage
	Einschraubwinkel Male elbow/raccord angulaire	6mm
	Einschraubwinkel Male elbow/raccord angulaire	8mm
	Einschraubwinkel Male elbow/raccord angulaire	1/4"
	Adapter raccord	1/8"-1/8"
	Blindstopfen pipe plug/fermeture	

$L = S + 209$

(bei opt. Weglänge 1mm = 210mm)
(at optical pathlength 1mm = 210mm)
(à trajet optique 1mm = 210mm)

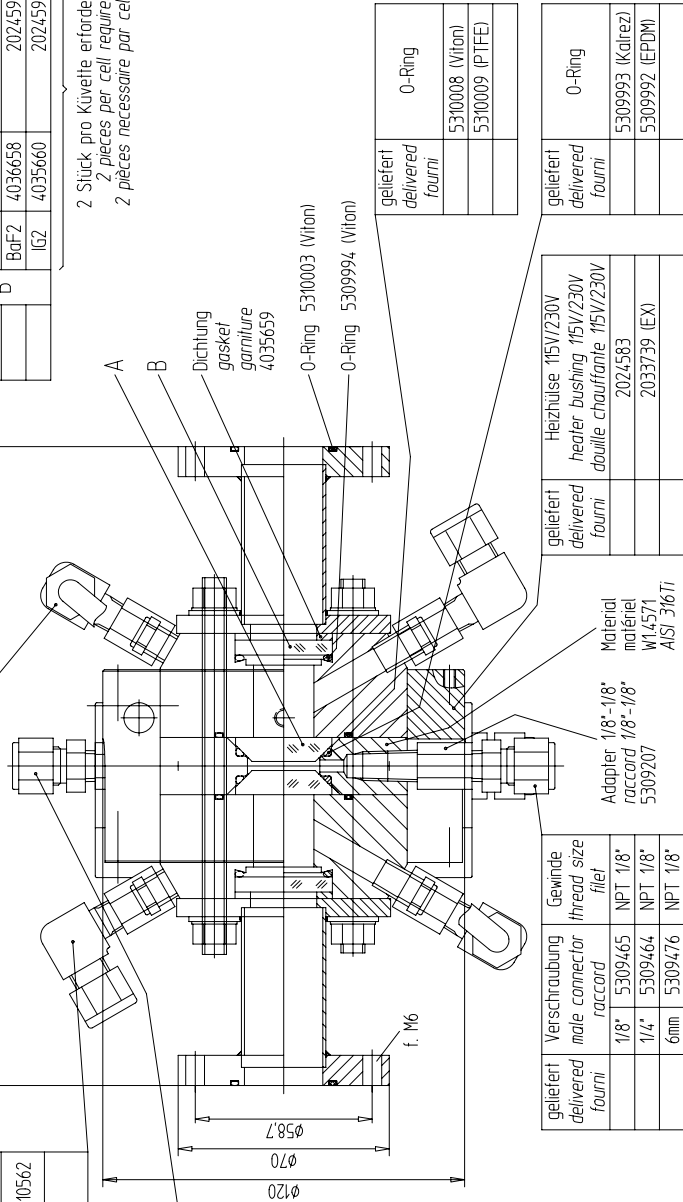

geliefert delivered fourni	Verschraubung male connector raccord	Gewinde thread size filet
	6mm	NPT 1/8"
	8mm	NPT 1/8"
	1/8"	NPT 1/8"
	1/4"	NPT 1/8"

geliefert delivered fourni	Verschraubung male connector raccord	Gewinde thread size filet
	1/8"	NPT 1/8"
	1/4"	NPT 1/8"
	6mm	NPT 1/8"
	8mm	NPT 1/8"

geliefert delivered fourni	O-Ring
	5310008 (Viton)
	5310009 (PTFE)

geliefert delivered fourni	Heizhülse 115V/230V heater bushing douille chauffante 115V/230V
	2024583
	2033739 (EX)

geliefert delivered fourni	O-Ring
	5309993 (Kaltrez)
	5309992 (EPDM)

8.3 **Heating jacket dimensions and Part Nos.**

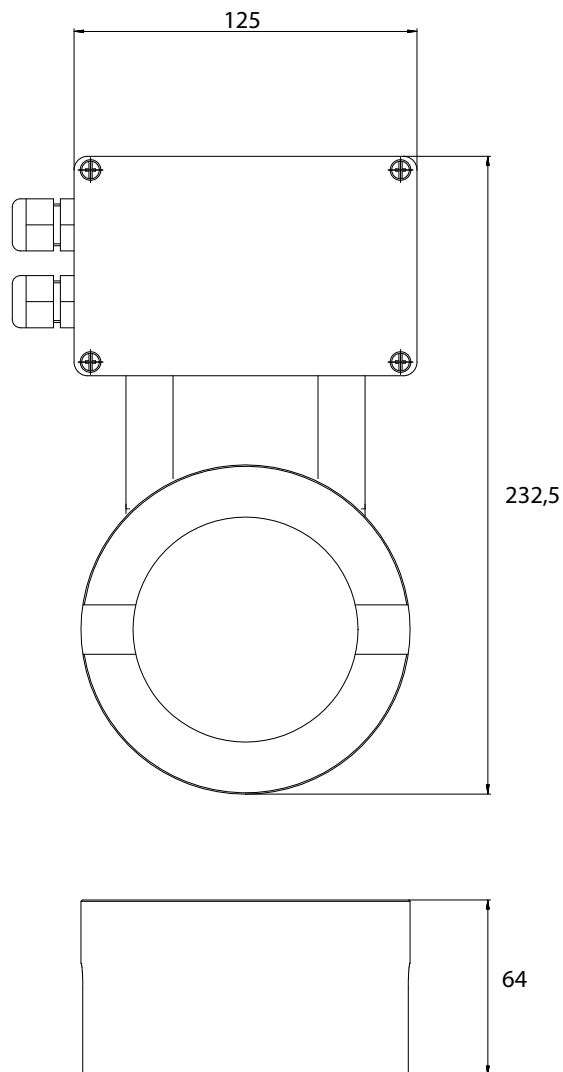

Heating jacket, complete, Part No.: 2024583

8.4

Technical data



Refer to the Data Sheet delivered with the cell for the materials used.

Cell characteristics	
Optical path length	FGK01: < 14 mm (< 0.55 in.) FGK15: 15 .. 39 mm (0.59 .. 1.53 in.) FGK40: 40 .. 99 mm (1.57 .. 3.9 in.) The optical path length is preset with an intermediate ring.
Materials with media contact: - Cell body - Windows - Seals	Stainless steel 1.4571 (SS316Ti) → Data Sheet enclosed with the cell → Data Sheet enclosed with the cell
Weight	Approx. 5 kg (11 lb.) (with 4 mm optical path length)
Measured medium volumes	Approx. 2.2 cm ³ (0.134 cu.in.) (with 4 mm optical path length)

Mechanical installation	
Fitting position	Preferably horizontal, measured medium inlet from below
Tubes: - Measured medium inlet - Measured medium outlet - Purge gas inlet and outlet	Screw fitting for tube outer diameter: 1/8 " 6 mm 6 mm

Operating conditions	
Ambient temperature	Without heating jacket: +5 .. +75 °C (+40 .. +170 °F) With heating jacket: +5 .. +45 °C (+40 .. +113 °F)
Storage temperature	-20 .. +70 °C (0 .. +160 °F)
Relative humidity	Max. 80%
Degree of protection	Cell body: IP 67 Heating jacket: IP 20
Heating jacket heating temperature Temperature controller (external)	Adjustable to max. +60 °C (140 °F) Temperature controller for Pt100
Temperature sensor	1*Pt100
Safety temperature switch (internal)	Cutout temperature +75 °C (167 °F) Independent reset at approx. +62 °C (144 °F)
Heating up time	From room temperature to approx. +50 °C (+120 °F): Approx. 1 hour
Sample compartment operating pressure	With quartz, CaF ₂ , IG2, sapphire window: 8 mPa (80 bar) at max. +50 °C (+120 °F). (Max. test pressure: 21 mPa (210 bar) at +50 °C (+120 °F).
Operating pressure, purge gas compartment	2 mPa (20 bar) at max. +25 °C (+77 °F) (Max. test pressure: 6 mPa (60 bar) at +25 °C (+77 °F).

Measured medium (requirements)	
Temperature	Thermostatically controlled to cell temperature Max. +180°C (+350°F)
Sample gas flow rate Measured liquid flow rate	100 .. 600 l/h 2 .. 8 l/h
Sample gas purity	Dust-free and free from condensed components

Purge gas (expendable item)	
Flow rate	Approx. 2 l/h

Subject to change without notice

Electrical installation (heating jacket)	
Supply voltage	115 or 230 V +10 % / -15 %; 50 .. 60 Hz
Power input	110 VA
Mains fuse (external):	Via temperature controller or external 4 A (for 115 V and 230 V)
Electrical connection lines: - Power supply - Pt100	3 * AWG 18 2 * AWG 20

A		
Ambient conditions	41	
C		
Clearing malfunctions	35	
Compliance	38	
Connection		
- Measured medium	17	
- Purge gas	20	
D		
Disposal	28	
E		
Electrical installation	21	
Exploded drawing	32	
G		
Glossary	2	
I		
Information symbols	3	
Installation	15	
Intended use	8	
M		
Mains connection	21	
Maintenance	29, 31	
Maintenance plan	30	
O		
Operation	25	
P		
Part No.		
- Cell	12	
- Cell spare parts	39	
- Heating jacket	40	
- Spare parts	30	
Pressure test	16	
Product description	11	
Product identification	12	
Purge gas compartment	12	
S		
Safety temperature switch	36	
Sample compartment	12	
Shutdown	27	
Signal words	3	
Specifications	37	
Symbols (explanation)	3	
T		
Technical data	41	
Temperature switch	36	
Thermostatic control	13	
Troubleshooting	35	
Type plate	12	
W		
Warning symbols, warning levels	3	

FGK

8009513/V-3-0/2012-07 | Subject to change without notice

SICK worldwide

You will find our local subsidiary
or agency at:
www.sick.com

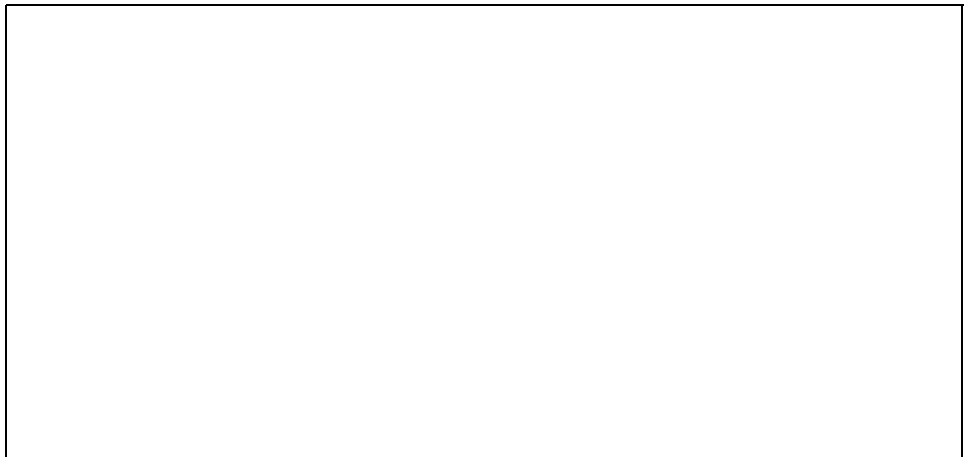

Your local sales and service partner