

SLG-2

Switching automation light grid

SICK
Sensor Intelligence.



Described product

SLG-2

Manufacturer

SICK AG
Erwin-Sick-Str. 1
79183 Waldkirch
Germany

Legal information

This work is protected by copyright. Any rights derived from the copyright shall be reserved for SICK AG. Reproduction of this document or parts of this document is only permissible within the limits of the legal determination of Copyright Law. Any modification, abridgment or translation of this document is prohibited without the express written permission of SICK AG.

The trademarks stated in this document are the property of their respective owner.

© SICK AG. All rights reserved.

Original document

This document is an original document of SICK AG.



Contents

1	About this document.....	5
1.1	Information on the operating instructions.....	5
1.2	Scope.....	5
1.3	Explanation of symbols.....	5
1.4	Customer service.....	6
2	Safety information.....	7
2.1	Intended use.....	7
2.2	Limitation of liability.....	8
2.3	Requirements for skilled persons and operating personnel.....	8
2.4	Hazard warnings and operational safety.....	9
2.5	Repair.....	9
3	Product description.....	10
3.1	Product ID.....	10
3.1.1	Type labels.....	10
3.2	Product features and functions.....	10
3.2.1	Device view.....	10
3.2.2	Measurement principle.....	11
3.2.3	Detection height.....	11
3.2.4	Beam separation, minimum object size, minimum object width and minimum object length.....	11
3.2.5	Scan time, repeatability, minimum dwell time, response time.....	15
3.2.6	Sensing range.....	15
3.2.7	Measurement information.....	16
4	Mounting.....	17
4.1	Scope of delivery.....	17
4.2	Mounting requirements.....	17
4.3	Mounting conditions.....	17
4.4	Alignment.....	19
4.5	Mounting the light grid.....	19
5	Electrical installation.....	21
5.1	Notes on electrical installation.....	21
5.2	Pin assignment of the connections.....	22
5.3	Connecting the supply voltage.....	22
6	Commissioning.....	23
6.1	Preparation.....	23
6.2	Teach-in.....	23
6.2.1	Auto teach-in.....	23
6.2.2	Teach-in via pin 2 / MF.....	24
6.2.3	Teach via IO-Link or SOPAS ET.....	24

6.2.4	Switching threshold setting after teach-in.....	24
7	Operation.....	25
7.1	Configuration options.....	25
7.2	Functions structure.....	25
7.3	Structure of SOPAS.....	26
7.4	Basic information on SLG-2.....	26
7.4.1	Basic information on SLG-2 via IO-Link.....	27
7.5	General settings.....	28
7.5.1	Alignment aid via SOPAS ET.....	28
7.5.2	General settings via IO-Link.....	29
7.6	Zones / Q_{ints}.....	30
7.6.1	Zones/Q_{ints} via IO-Link.....	34
7.7	Smart Task.....	35
7.7.1	Smart Task via IO-Link.....	37
7.8	Process data.....	38
7.8.1	Manually customizing the process data.....	39
7.8.2	Process Data via IO-Link.....	39
7.9	Diagnostic settings.....	39
7.9.1	Diagnostic settings via IO-Link.....	41
7.10	IO-Link specific settings.....	42
8	Diagnostics and troubleshooting.....	44
8.1	IO-Link specific diagnostic information.....	44
8.1.1	Device Status.....	44
8.1.2	Events.....	44
8.1.3	Detailed Device Status.....	45
8.2	Device-specific diagnostic information.....	45
8.3	Diagnostic information via the display LEDs.....	46
8.4	Sync error.....	47
8.5	Troubleshooting.....	48
9	Maintenance.....	49
9.1	Maintenance.....	49
10	Decommissioning.....	50
10.1	Disassembly and disposal.....	50
10.2	Returning devices.....	50
11	Technical data.....	51
11.1	Resolution.....	54
11.1.1	Minimum object size (MDO).....	54
11.1.2	Minimum object length (MOL).....	57
11.1.3	Minimum object width (MOW).....	58
11.2	Dimensional drawings.....	60
12	Annex.....	62

1 About this document

1.1 Information on the operating instructions

These operating instructions provide important information on how to use devices from SICK AG.

Prerequisites for safe work are:

- Compliance with all safety notes and handling instructions supplied
- Compliance with local work safety regulations and general safety regulations for device applications

The operating instructions are intended to be used by qualified personnel and electrical specialists.



NOTE

Read these operating instructions carefully before starting any work on the device, in order to familiarize yourself with the device and its functions.

The instructions constitute an integral part of the product and are to be stored in the immediate vicinity of the device so they remain accessible to staff at all times. Should the device be passed on to a third party, these operating instructions should be handed over with it.

These operating instructions do not provide information on operating the machine in which the device is integrated. For information about this, refer to the operating instructions of the specific machine.

1.2 Scope

These operating instructions serve to incorporate the device into a customer system. Step-by-step instructions are given for all required actions.

These instructions apply to all listed device variants of the product.

Available device variants are listed on the online product page.

▶ www.sick.com/SLG-2

Commissioning is described using one particular device variant as an example.

1.3 Explanation of symbols

Warnings and important information in this document are labeled with symbols. The warnings are introduced by signal words that indicate the extent of the danger. These warnings must be observed at all times and care must be taken to avoid accidents, personal injury, and material damage.



DANGER

... indicates a situation of imminent danger, which will lead to a fatality or serious injuries if not prevented.



WARNING

... indicates a potentially dangerous situation, which may lead to a fatality or serious injuries if not prevented.

**CAUTION**

... indicates a potentially dangerous situation, which may lead to minor/slight injuries if not prevented.

**NOTICE**

... indicates a potentially harmful situation, which may lead to material damage if not prevented.

**NOTE**

... highlights useful tips and recommendations as well as information for efficient and trouble-free operation.

1.4 Customer service

If you require any technical information, our customer service department will be happy to help. To find your agency, see the final page of this document.

**NOTE**

Before calling, make a note of all type label data such as type code, serial number, etc., to ensure faster processing.

2 Safety information

This document is an original document of SICK AG. All rights reserved. Subject to change without notice.

Read these safety notes and take them into account when working with the sensor. The safety notes do not describe how to use the sensor.

You can find technical data and information on commissioning the sensor in the operating instructions. They can be downloaded at this Internet site: www.sick.com (enter the part number of the sensor in the search field and you will find the operating instructions under Downloads).



- Connection, mounting, and setting is only to be performed by trained specialists.



- Not a safety component in accordance with the EU Machinery Directive.



- Do not install the sensor in places exposed to direct sunlight or other weather conditions unless this is expressly permitted in the operating instructions.



WARNING

Fire

Electrical connections must be made in compliance with local and national electrical regulations and standards. The sensor must be protected with a fuse suitable for the cross-circuit of the connecting cable; for details, see the operating instructions.

For devices with a supply voltage > 50 V (AC), 75 V (DC):



WARNING

Lost of electrical safety (protection class)

When commissioning, protect the device from moisture and contamination.

Unless stated otherwise in the operating instructions, the sensor may only be used in an area with maximum degree of contamination 3, maximum overvoltage category II and a maximum altitude of 2,000 m above sea level.

2.1 Intended use

The SLG-2 is a switching automation light grid.

It is solely intended for the optical and non-contact detection of objects, animals, and persons.

A switching automation light grid is designed for mounting and may only be operated according to its intended function. For this reason, it is not equipped with direct safety devices. The system designer must provide measures to ensure the safety of persons and systems in accordance with the legal guidelines. In the event of any other usage or modification to the SLG-2 (e.g., due to opening the housing during mounting and electrical installation) or in the event of changes made to the SICK software, any claims against SICK AG under the warranty will be rendered void.

2.2 Limitation of liability

Applicable standards and regulations, the latest state of technological development, and our many years of knowledge and experience have all been taken into account when assembling the data and information contained in these operating instructions. The manufacturer accepts no liability for damage caused by:

- Failure to observe the operating instructions
- Improper use
- Use by untrained personnel
- Unauthorized conversions
- Technical modifications
- Use of unauthorized spare parts, wear and tear parts, and accessories

With special variants, where optional extras have been ordered, or owing to the latest technical changes, the actual scope of delivery may vary from the features and illustrations shown here.

2.3 Requirements for skilled persons and operating personnel



WARNING

Risk of injury due to insufficient training!

Improper handling of the device may result in considerable personal injury and material damage.

- All work must only ever be carried out by the stipulated persons.

The operating instructions state the following qualification requirements for the various areas of work:

- **Instructed personnel** have been briefed by the operating entity about the tasks assigned to them and about potential dangers arising from improper action.
- **Skilled personnel** have the specialist training, skills, and experience, as well as knowledge of the relevant regulations, to be able to perform tasks assigned to them and to detect and avoid any potential dangers independently.
- **Electricians** have the specialist training, skills, and experience, as well as knowledge of the relevant standards and provisions to be able to carry out work on electrical systems and to detect and avoid any potential dangers independently. In Germany, electricians must meet the specifications of the BGV A3 Work Safety Regulations (e.g., Master Electrician). Other relevant regulations applicable in other countries must be observed.

The following qualifications are required for various activities:

Activities	Qualification
Mounting, maintenance	<ul style="list-style-type: none"> ■ Basic practical technical training ■ Knowledge of the current safety regulations in the workplace
Electrical installation, device replacement	<ul style="list-style-type: none"> ■ Practical electrical training ■ Knowledge of current electrical safety regulations ■ Knowledge of the operation and control of the devices in their particular application
Commissioning, configuration	<ul style="list-style-type: none"> ■ Basic knowledge of the design and setup of the described connections and interfaces ■ Basic knowledge of data transmission ■ Knowledge of the operation and control of the devices in their particular application

Activities	Qualification
Operation of the devices in their particular application	<ul style="list-style-type: none"><li data-bbox="762 218 1422 275">■ Knowledge of the operation and control of the devices in their particular application<li data-bbox="762 275 1422 331">■ Knowledge of the software and hardware environment in the application

2.4 Hazard warnings and operational safety

Please observe the safety notes and the warnings listed here and in other chapters of these operating instructions to reduce the possibility of risks to health and avoid dangerous situations.

2.5 Repair

The product is a replacement device. The device is not intended to be repaired. Interference with or modifications to the device on the part of the customer will invalidate any warranty claims against SICK AG.

3 Product description

3.1 Product ID

3.1.1 Type labels



Figure 1: Type label

- ① Device type
- ② Part number (1xxxxxx)
- ③ Part number sender / receiver only (2xxxxxx)
- ④ Serial number: Dat.code + 4-digit sequential number + UL site identifier
- ⑤ Data Matrix code (part number 1xxxxxx + part number 2xxxxxx + serial number)

3.2 Product features and functions

3.2.1 Device view

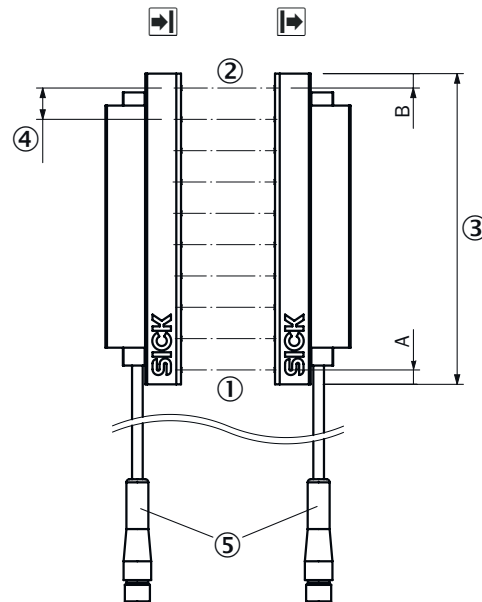

Figure 2: Device view

- ▣ Receiver (R)
- ▣ Sender (T)
- ① First light beam
- ② Last light beam
- ③ Detection height
- ④ Beam separation d_c
- ⑤ Cable with male connector

	A ¹	B ²
SLG10x-xxxxxxxxx	4.6 mm	4.6 mm ³
SLG25x-xxxxxxxxx		19.6 mm ³
SLG50x-xxxxxxxxx		44.6 mm ³

- 1 Distance from lower edge to first light beam
- 2 Distance from upper edge to last beam
- 3 For a detection height < 700 mm, the dimension may vary.

The SLG-2 is an optical light grid. It consists of a sender and a receiver. The sender consists of several sender elements (LEDs) and actuation electronics. The receiver consists of receiver optics, several receiver elements (photodiodes) and control unit.

3.2.2 Measurement principle

Providing no object is located between the sender and receiver elements, the light beams from the sender elements will hit the receiver elements. If an object is located between the sender and receiver elements, the light beams will be blocked, depending on the size of the object.

The detection area is determined by the detection height and the sensing range of the light grid. The detection height is determined by the beam separation and the number of beams. The sensing range of the light grid is the distance between sender and receiver.

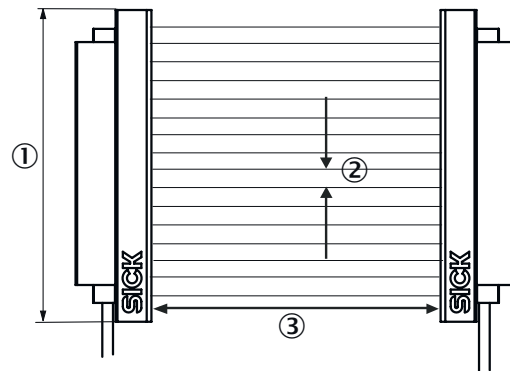

Figure 3: Detection area of the SLG-2

- ① Detection height
- ② Beam separation
- ③ Sensing range

3.2.3 Detection height

The detection heights of the SLG-2 are between 100 mm and 2,400 mm:

- 100 mm increments between 100 mm and 800 mm.
- 200 mm increments between 800 mm and 2,400 mm.

3.2.4 Beam separation, minimum object size, minimum object width and minimum object length

The beam separation is the distance from the center of one LED to the center of the nearest LED.

The beam separation is an important parameter for determining the resolution. To meet different resolution requirements, the SLG-2 is available with different beam separation variants.

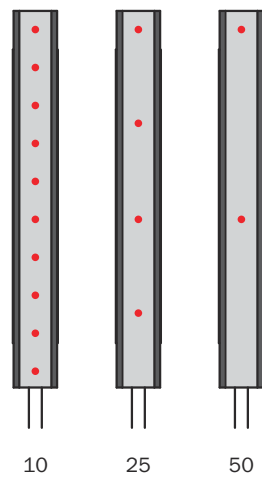

Figure 4: Available SLG-2 beam separations

To further improve the resolution, the cross-beam function is also available.

Resolution / minimum object size (MDO) in parallel-beam mode

With the parallel-beam function, each light beam is received by the receiver element situated directly opposite. In order for an object to be detected continuously, it must completely cover at least one beam. This minimum object size is also referred to as **Minimum Detectable Object (MDO)**. The calculation of the MDO is as follows:

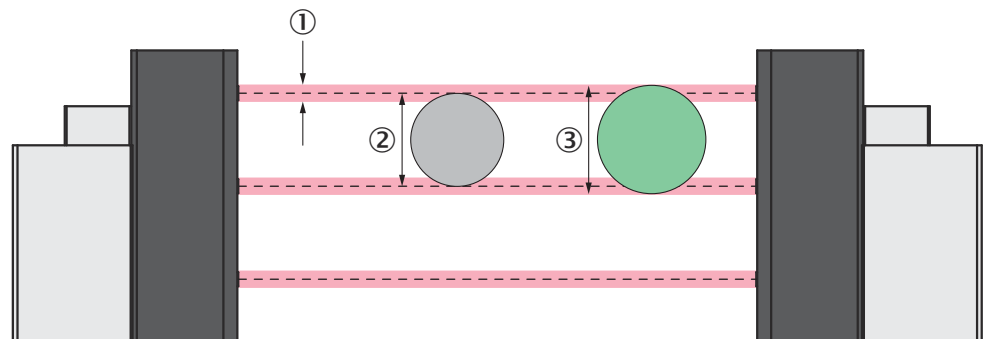

Figure 5: Minimum object size

- ① Beam diameter
- ② Object is not completely reliably detected
- ③ Object is reliably detected (meets requirements of minimum detectable object size)

$$\text{MDO} = \text{beam separation} + 5 \text{ mm}$$

Resolution / minimum object size (MDO) in cross-beam mode

The parallel-beam function is used for measuring by default. With the cross-beam function, a sender LED projects beams to several receiver diodes and evaluates them. This increases the measurement accuracy and enables the detection of smaller objects. Several cross-beam options are available:

- 3-fold cross beam: Parallel beam + the adjacent beam on each side
- 5-fold cross beam: Parallel beam + two adjacent beams on each side
- 7-fold cross beam: Parallel beam + three adjacent beams on each side
- 9-fold cross beam: Parallel beam + four adjacent beams on each side

The minimum detectable object size or the resolution depends on the position of the object within the detection area (see image).

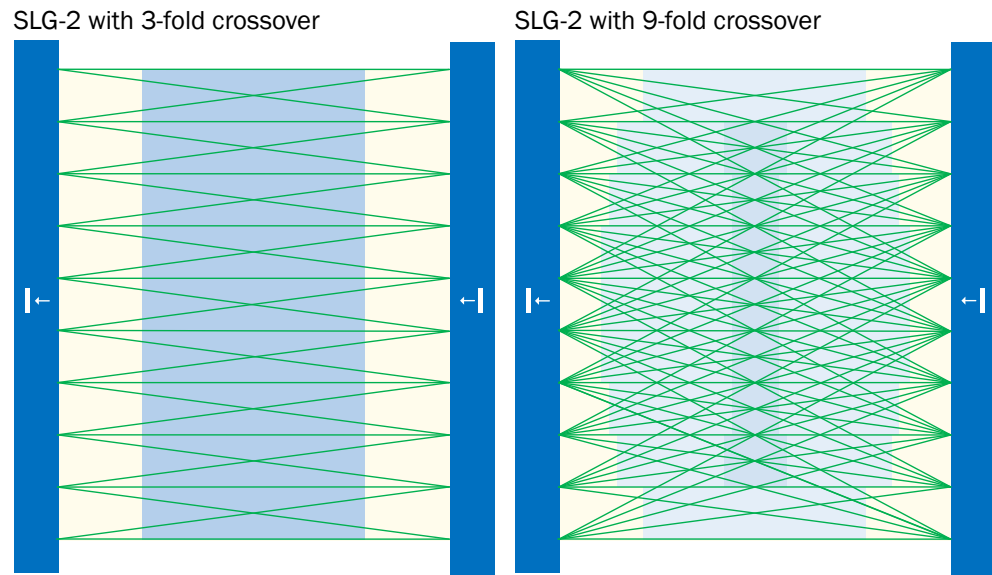

- The cross-beam function is only useful for object detection ($NBB \geq 1$).
- Due to the crossed beams, the cross-beam function is very useful for detecting very narrow but wide objects (e.g. metal sheets).
- Use of the cross-beam function increases the response time.
- With the cross-beam function, a minimum distance needs to be maintained between sender and receiver. The minimum distance depends on the aperture angle of the light grid.



NOTE

Detailed information on resolution, response times and minimum distances can be found in chapter [chapter 11](#).

Minimum object size (MDO):

- MDO 3-fold cross beam @10 mm beam separation = up to 9 mm
- MDO 9-fold cross beam @10 mm beam separation = up to 6.5 mm



NOTE

Detailed information on the MDO in cross-beam mode can be found in chapter [chapter 11](#).

Resolution / minimum object width (MOW)

For the detection of very flat objects, the cross-beam function with the 7x or 9x cross-beam option is suitable. Due to the different angles of the beams between the sender and receiver, reliable detection of even an infinitely flat object with a certain minimum width is possible.

Reliable detection depends on several factors:

- Beam separation
- Distance from sender and receiver
- Minimum width of the “infinitely” thin object
- Location of the object between sender and receiver (better resolution in the middle range)

MOW = minimum object width

Detailed technical information on the detection capability and the minimum object width can be found in [chapter 11.1.3](#).

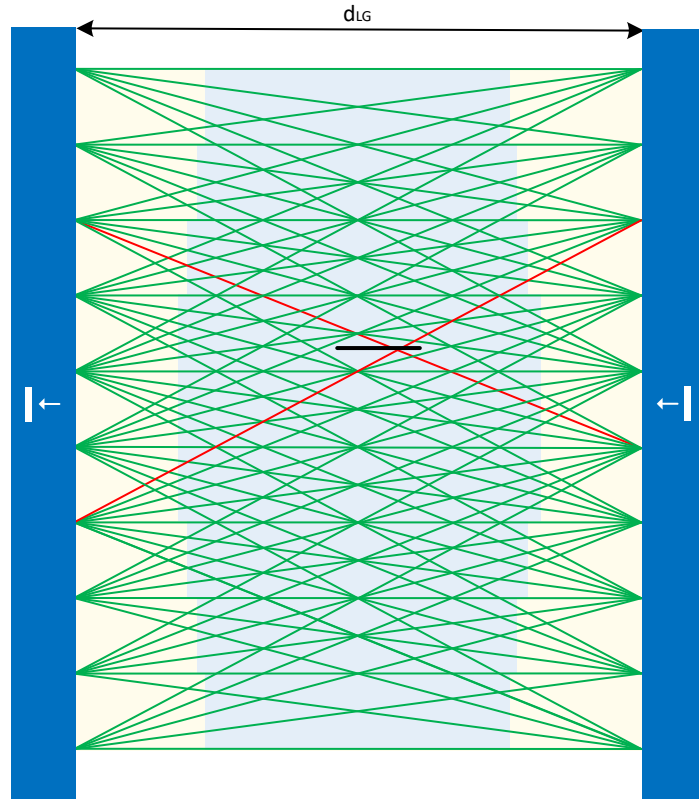

Figure 6: Detection of a very narrow object using the cross-beam function

Minimum object length (MOL):

The minimum object length designates the minimum length of an object that is reliably detected. Since the SLG-2 has a cycle time or minimum dwell time of a few milliseconds, the minimum object length depends on the object velocity at which the object orthogonally passes the SLG-2. A static object has a minimum object length of 3 mm. The following formula applies to the calculation of the minimum object length:

$$\text{MOL} = \text{object speed} \times \text{minimum dwell time} + 3 \text{ mm}$$



NOTE

The minimum dwell time depends on the device type and can be determined via the information in chapter [chapter 11](#).

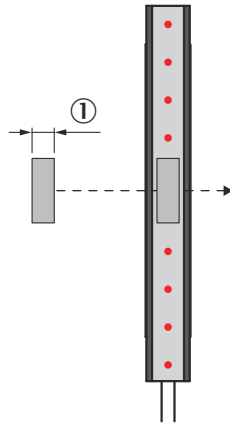

Figure 7: Minimum detectable object length

① Minimum detectable object length

3.2.5 Scan time, repeatability, minimum dwell time, response time

To prevent mutual interference between the individual beams and to achieve the resolution, the SLG-2 light grid sequentially cycles through each beam.

The time required by the light grid for one pass is called the scan time.

Due to this sequential processing, the scan time of the system depends on the number of beams. The total times are short, however, because the cycle time between two channels is in the μs range.

All times given are maximum or worst-case values.

Detailed information on the times can be found in [chapter 11](#).

Repeatability

The repeatability is the maximum time deviation between two measurements. The repeatability in parallel-beam mode is thus equal to the scan time.

Repeatability = scan time

The following applies in cross-beam mode:

Repeatability = $1.5 \cdot \text{scan time}$

Minimum dwell time

The minimum dwell time is the time that an object must dwell between the sender and receiver in order to be reliably detected. The minimum dwell time is twice the scan time.

- Minimum dwell time = $2 \cdot \text{scan time}$

Response time

The response time is the maximum time it takes for an output to react following the detection of an object.

3.2.6 Sensing range

Basically, the SLG-2 light grid distinguishes between the maximum sensing range and the recommended sensing range.

Furthermore, the SLG-2 light grid is available in different sensing range options.

Maximum sensing range

The maximum sensing range is the guaranteed working distance between sender and receiver without operating reserve or without taking into account other external influences such as contamination.

If the SLG-2 is operated within this sensing range, a clean environment and regular cleaning are required.

Recommended sensing range

Within the recommended sensing range, the light grid has the highest detection reliability with the greatest possible resistance.

Sensing range options

The SLG-2 light grid is available in different sensing range options. These include:

Table 1: Sensing range options

Variant	Recommended sensing range	Maximum sensing range	Application
SLGxxS-xxxxARxxxxx	440 mm - 3,500 mm	150 mm - 4,900 mm	Standard device
SLGxxS-xxxxCRxxxxx	440 mm - 1,700 mm	150 mm - 2,400 mm	Very high sunlight resistance
SLGxxS-xxxxERxxxxx	70 mm - 1,500 mm	70 mm - 2,150 mm	For small sensing ranges

When using the cross-beam function, other sensing range limitations must be observed.

Detailed information can be found in [chapter 11](#).

3.2.7 Measurement information

The SLG-2 can output the raw data via the serial interfaces in the form of the beam status so the user can evaluate the data him/herself.

In addition, the SLG-2 can process the raw data via various functions (e.g. LBB for height measurement or zone and logic functions) and output them via a serial interface or push/pull outputs.

4 Mounting

4.1 Scope of delivery

- SLG-2:
Light grid sender + light grid receiver (when ordered as a pair)
- Quickstart
- Safety notes

The mounting accessories and connecting cables are not included in the scope of delivery and must be purchased separately.

4.2 Mounting requirements

- Compliance with the minimum distance between sender and receiver in parallel-beam or cross-beam mode, [see "Technical data", page 51](#).
- Typical space required for device, [see "Technical data", page 51](#).
- Comply with technical data, such as the permitted ambient conditions for operation of the device (e.g., temperature range, EMC interference emissions, ground potential).
- To prevent condensation, avoid exposing the device to rapid changes in temperature.
- For outdoor use only with appropriate safeguard / protective housing
- Protect the device from direct sunlight.
- Protect the device from external light sources.
- Only fasten the device using the slot provided for this purpose and the mounting bracket or sliding nuts available as accessories.
- Shock and vibration-free mounting

4.3 Mounting conditions

Synchronization beam

For measuring tasks, it must be ensured that the first or last beam is always free, [see "Sync error", page 47](#).

Avoiding reflections

Reflective objects in the field of view may cause the image to be reflected or diverted away. This means that reliable detection cannot be guaranteed.

Depending on the sensing range, make sure that there are no reflective objects in the field of view of the light grid.

The minimum distance to reflective materials can be seen in the following graphic.

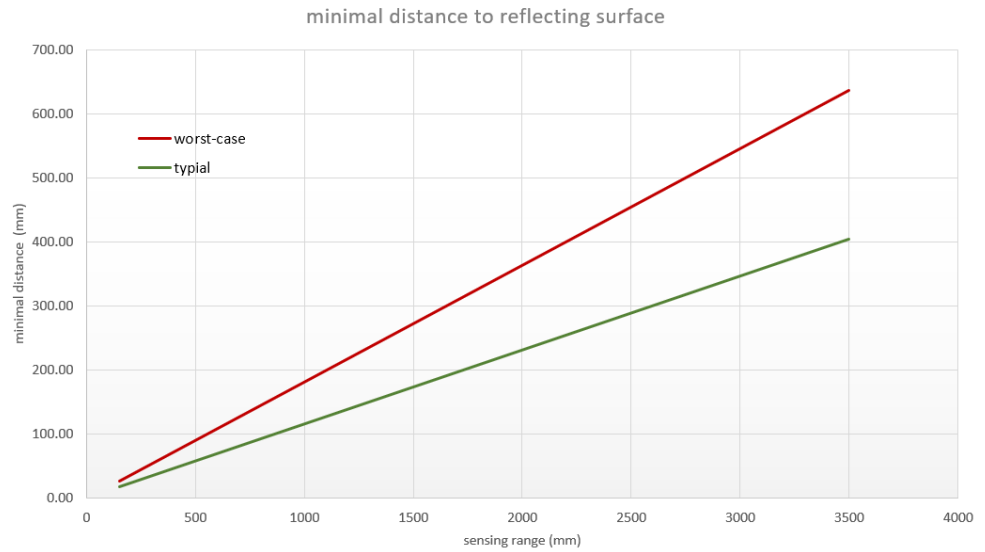

Figure 8: Minimum distance SLG-2 to reflective materials

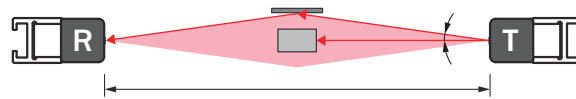

Figure 9: Distance to reflective objects

Avoiding interference with other SLG-2 light grids

When several SLG-2s are mounted close to one another, there is a risk of mutual interference. Therefore, when mounting two SLG-2s close to one another, their light beams should be oriented in opposite directions.



Figure 10: Light grid installed in opposite directions R = Receiver; T = Transmitter (sender)

**NOTE**

If the installation is not counter-rotating, make sure that there is a minimum distance between the two light grids, which can be taken from the following diagram:

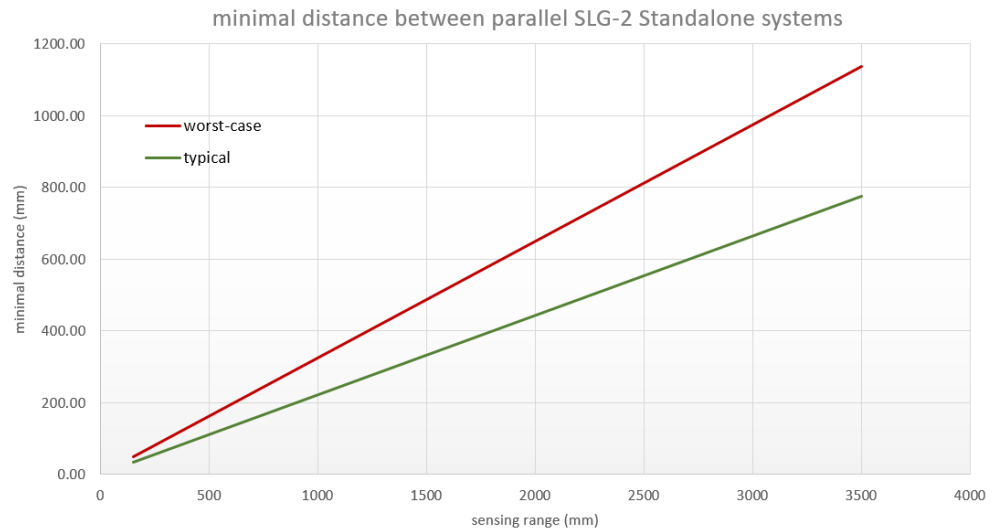

Figure 11: Minimum distance between 2 SLG-2 light grids

**NOTE**

If more than two SLG-2 light curtains are used, the FlexChain system with cascadable SLG-2 light grids is recommended.

4.4 Alignment

When mounting, the sender and receiver must be aligned as accurately as possible.

Absolute accuracy r of the alignment depends, among other things, on sensing range d and can be calculated with availability angle α . This availability angle is 4.5° .

$$r = \tan(\alpha) \cdot d$$

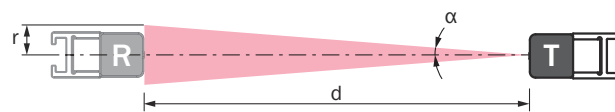

Figure 12: Alignment

**NOTE**

An alignment aid is available via IO-Link and SOPAS ET for precise alignment of the light grids. The description can be found in [chapter 7.5.1](#).

4.5 Mounting the light grid

The SLG-2 is available in a flat version (light emission on the wide side) and a slim version (light emission on the flat side). Mounting must be done properly.

**NOTE TIP**

Light emission of the light grid is always on the side of the optics front where there is **no** label.

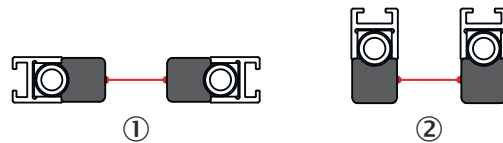

Figure 13: Slim vs. flat

- ① Slim model: Light emission on the thin side
- ② Flat model: Light emission on the wide side

The light grids are to be mounted with the mounting accessories listed below, taking into account the distances listed below.

If large light grids or light grids in applications with high vibration and impact loads are used, the use of 2 mounting sets per light grid is recommended.

Accessories available for mounting:

- Mounting bracket BEF-SLG2-SET1 (2111623)
- Mounting slot BEF-NUT-SLG2 (2111624)

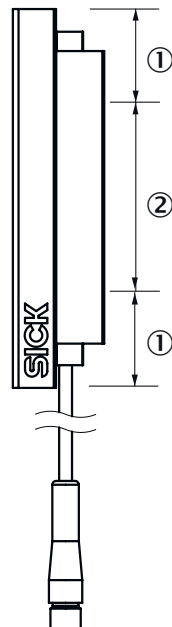

Figure 14: Mounting

Recommended holder spacing:

- ① Distance housing edge - mounting bracket ≤ 10 cm
- ② Distance mounting bracket - mounting bracket ≤ 75 cm¹⁾

Observe maximum torque for both fastening types of 2 Nm.²⁾

1) Applications with high mechanical load ≤ 40 cm

2) For mounting brackets with part number 2111623, the use of a washer under the screw head is recommended.

5 Electrical installation

5.1 Notes on electrical installation



NOTICE

Equipment damage due to incorrect supply voltage!

An incorrect supply voltage may result in damage to the equipment.

- Only operate the SLG-2 with safety/protective extra-low voltage (SELV/PELV).
- The SLG-2 is a device of protection class III.



NOTICE

Equipment damage due to incorrect supply voltage!

An incorrect supply voltage may result in damage to the equipment.

- Only operate the SLG-2 with an LPS (limited power source) in accordance with IEC 60950-1 or an NEC Class 2 power supply unit.



NOTICE

Equipment damage or unpredictable operation due to working with live parts!

Working with live parts may result in unpredictable operation.

- Only carry out wiring work when the power is off.
- Only connect and disconnect electrical connections when the power is off.



NOTICE

Device damage due to incorrect connection!

Incorrect connection may cause damage to the SLG-2.

- **The electrical installation must only be performed by electrically qualified personnel.**
- **Standard safety requirements must be observed when working on electrical systems!**
- Only switch on the supply voltage for the device when the connection tasks have been completed and the wiring has been thoroughly checked.
- When using extension cables with open ends, ensure that bare wire ends do not come into contact with each other (risk of short-circuit when supply voltage is switched on!). Wires must be properly insulated from each other.
- Wire cross-sections in the supply cable from the user's power system must be selected in accordance with the applicable standards.
- Only operate the device with an LPS (limited power source) in accordance with IEC 60950-1 or an NEC Class 2 power supply unit.
- All circuits connected to the device must be designed as SELV/PELV circuits.
- Operation in short-circuit protected network at max. 8 A.

The IP enclosure rating for the device is only achieved under the following conditions:

- The cables plugged into the connections are screwed tight.

If these instructions are not complied with, the IP enclosure rating for the device is not guaranteed!

5.2 Pin assignment of the connections

Table 2: Pin assignment

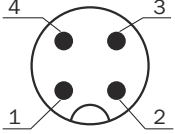
1 = BN	+ (L+)	
2 = WH	MF	
3 = BU	- (M)	
4 = BK	Q _{L1} / C	

The Q_{L1} / C (pin 4) and MF (pin 2) interfaces can be configured via the SOPAS engineering tool (in conjunction with the SI-LINK2 master (SICK part number: 1061790)) or directly via the IO-Link interface. MF (pin 2) can be configured as input or as output. Q_{L1} can only be configured as an output. Each digital interface can be assigned different functions, [chapter 7.7](#).

Pre-configured device variants are available (see www.sick.com/SLG-2).

5.3 Connecting the supply voltage

Only connect the sensors when the supply cable is de-energized.



NOTICE

Risk of damage to sensors

The sensors can become damaged if they are connected to a voltage supply that is already switched on.

The sensors must be connected to a power supply unit with the following properties:

- Supply voltage 18 ... 30 V DC (SELV/PELV as per currently valid standards)
- The current consumption for the system consisting of sender and receiver is between 100 mA and 420 mA, [see "Technical data", page 51](#).

To ensure protection against short-circuits/overload in the customer's supply cables, the wire cross-sections used must be appropriately selected and protected.

6 Commissioning

6.1 Preparation

- Sender and receiver must be well aligned, see "Mounting", page 17.
- First put the receiver into operation, then the sender. After connecting the sensors, the green LED must light up on the sender and receiver (for IO-Link communication, the LEDs flash at 1 Hz (otherwise constantly on)).
- With **Auto-Teach** active: 2 s ... wait 26 s until the yellow LED stops flashing at 1 Hz.³⁾
- Check alignment again. As an alignment aid, the **Alignment aid** function is also available via SOPAS ET, chapter 7.5.1.
- No objects should be located between the sender and the receiver. The light path must be clear.

6.2 Teach-in

After preparation, a teach-in can now be performed.

The duration of the teach-in process depends on the number of beams, the quality of alignment, the distance between sender and receiver and the **Cross beam Setting** and can be up to 24 s.

The teach-in automatically adjusts the switching threshold of each receiver element to the received signal intensity. The signal intensity depends on the distance between sender and receiver. The teach-in achieves the optimum resistance and detection reliability.

For stable operation, it is therefore mandatory to perform a teach-in under the following conditions:

- After a power-up operation (**System-power-on**)
- After each mechanical adjustment of the sender and/or receiver
- After a **Factory reset**
- After a **Teach-in error**
- After beam blanking or resetting the beam blanking (**Beam blanking**)
- After a **IO-Link data storage download**
- After changing the cross-beam setting (**Cross beam**)
- After deactivating the **Alignment aid**

If the teach-in was not performed correctly, the yellow LED on the SLG-2 receiver flashes at 8 Hz for 5 seconds. At the same time, a teach-in error is communicated via IO-Link, chapter 8.2. If the yellow LED flashes at 2 Hz, the signal strength is not sufficient. In both cases, check the alignment of the sender and receiver and the free light path between the sender and receiver.

There are different ways to perform the teach-in:

- Auto teach-in
- Teach-in via pin 2 / MF
- Teach-in via IO-Link and SOPAS ET

6.2.1 Auto teach-in

The **Auto-Teach-in** is performed automatically under the following conditions:

³⁾ The duration depends on the number of beams and the setting of the light grid. See also chapters "Technical data", page 51 "Initialization time" and "Teach-in time".

- Receiver is put into operation electrically.
- After a **Factory Reset**, if the device has activated the **Auto-Teach-in** option as **Factory-Default** .
- After a **IO-Link-DataStorage** download, if the **Auto-Teach-in** option is set as a download parameter.

Depending on the device variant, the **Auto-Teach-in** is active or deactivated. The setting can be changed via SOPAS ET or IO-Link, [chapter 7.5](#).

6.2.2 Teach-in via pin 2 / MF

Pin 2 / MF can be configured as a teach-in input.

With this setting, a teach-in is performed when a signal is applied to pin 2 / MF. Depending on the device variant, this option is active or deactivated.

The pin/MF setting can be changed via SOPAS ET or IO-Link, [chapter 7.7](#).

6.2.3 Teach via IO-Link or SOPAS ET

Teach-in can be performed at any time via IO-Link or SOPAS ET. This option is available for all SLG-2 light grid variants, [chapter 7.5](#).

6.2.4 Switching threshold setting after teach-in

Depending on the scenario, new switching thresholds are set after a teach-in, the teach-in results are discarded and previously stored switching thresholds are loaded, or the maximum sensitivity or maximum sensing range is set as the switching threshold.

When running a **Factory Resets**, the switching thresholds are set to maximum sensitivity. A downstream teach-in is necessary.

Action	Signal strength	Switching threshold setting, receiver	Yellow LED
Delivery state or factory reset		Maximum sensitivity or maximum sensing range	Deactivated
Teach-in, all beams covered	All beams < minimum signal	Maximum sensitivity or maximum sensing range	8 Hz for 5 seconds
Teach-in for partially covered beams	Some beams < minimum signal, some beams > minimum signal	Last saved teach results are used	8 Hz for 5 seconds
Teach-in when all beams are free	All beams > minimum signal	New thresholds are saved and used	Deactivated

7 Operation

7.1 Configuration options

The complete configuration of the SLG-2 is possible via the IO-Link interface. Using the SiLink2 master and the SOPAS ET configuration software, the SLG-2 can be configured directly on the computer.

For configuration via SOPAS ET, the sensor-specific **SOPAS Device Description** (SDD) is required.

Both SOPAS ET and the **SOPAS Device Description** can be downloaded free of charge at www.sick.com.

The interface-specific settings can be found at the end of the chapter, see "IO-Link specific settings", page 42.

7.2 Functions structure

The graphic below describes the functional structure of the SLG-2.

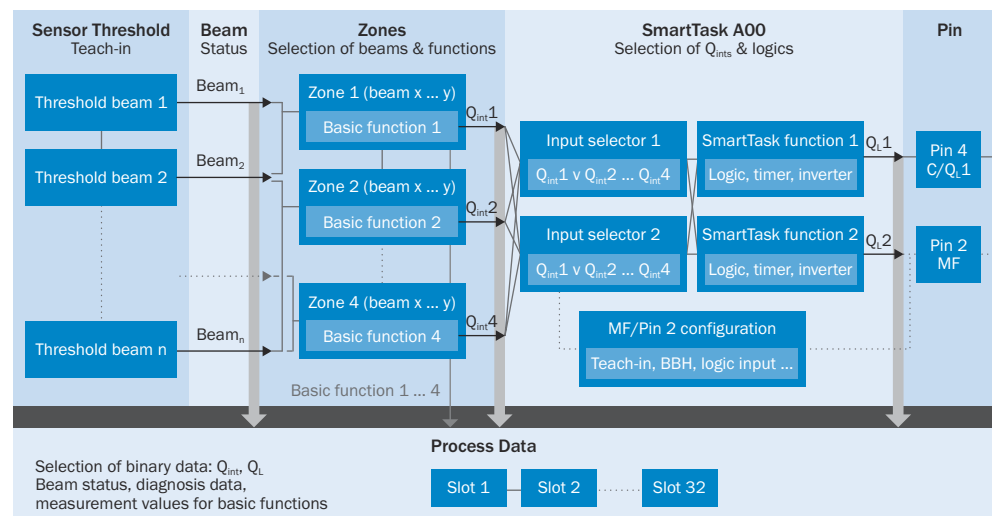

Figure 15: Function overview

In **Sensor thresholds**, the switching thresholds of all beams are automatically set via the teach-in depending on the sensing range, see "Commissioning", page 23.

Beam status: After the teach-in, the SLG-2 is ready for operation. Now either the states of each individual beam can be output via the process data (**Process data**) and/or the sensor data can be used for further processing.

Zones: In **Zones**, ranges between two beams can be defined in which evaluation within the zone is carried out by selectable functions. The resulting Q_{int} signals can either be used for further processing or output directly via the process data (**Process data**). Furthermore, height and width information of an object within a defined zone can still be output via the process data.

Smart Task:

two of the altogether four Q_{int} signals (internal) can be further processed / adapted by simple logic gates as well as by **Timing** and **Inverter** functions. Furthermore, an external input signal can be integrated into the processing. The processed signals Q_{L1} or Q_{L2} can be output via pin 4 or pin 2 (**Smart Task via IO-Link**) and/or via the process data (**Process data**).

Process Data: Via the process data, the information is transmitted to the controller via a serial interface. In addition to the **Beam status** and the evaluated beam information Q_{int} and Q_L , diagnostic information can also be transmitted. An individual configuration of the process data is possible.

Pin:

The output of binary data is possible via pin 4 / Q_{L1} or pin 2 / MF. The pins are freely configurable. However, only pin 2 / MF can be configured as input for further processing (e.g. as Smart Task input signal) ([Smart Task](#)).

7.3 Structure of SOPAS

The SOPAS interface for the SLG-2 is divided into different tabs (1). Each tab provides a specific set of parameterization functions. You can easily jump back and forth between the tabs. The structure of the visualization is similar in each tab:

- Important basic information is displayed on the left side of the SOPAS window (2). This is, for example, diagnostic information (see "[Diagnostics and troubleshooting](#)", page 44) or status of the Q_L s.
- The **Beam status** can be seen in the middle of the screen (3). When a beam is free, it is displayed in green with a continuous line. If the beam is blocked by an object, the beam is displayed with a red dashed line. The light grid orientation (male connector down or up) as well as blanked beams (gray display) are also displayed.
- On the right side of the SOPAS window (4), you can either make settings or call up individual information.

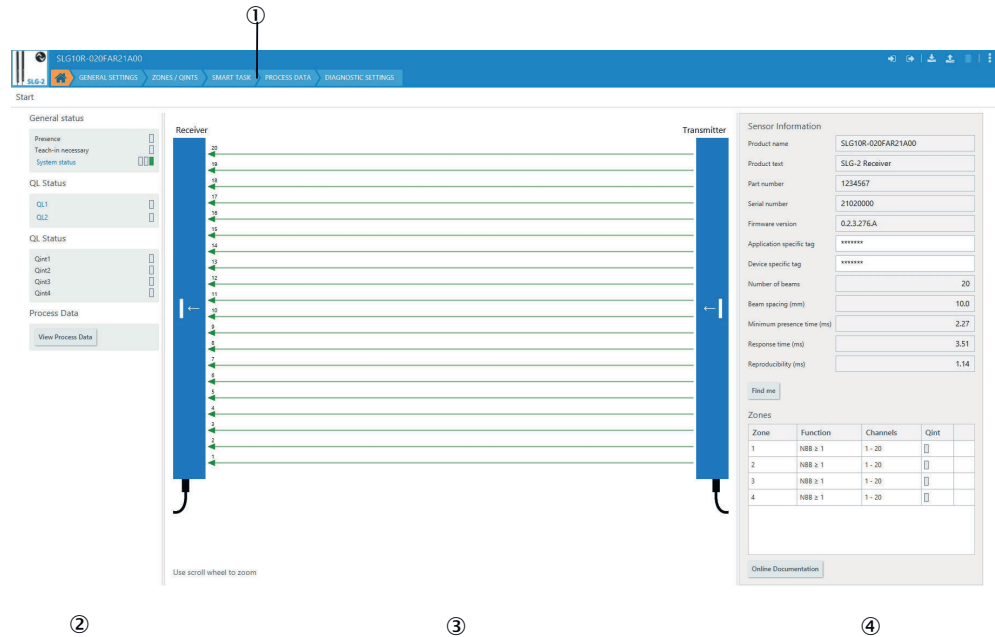

Figure 16: Structure of SOPAS – Home tab

7.4 Basic information on SLG-2

The **Hometab** (see figure 16, page 26) is used to get information and states about the connected SLG-2. This includes information such as detailed product information and performance values of the SLG-2.

7.4.1 Basic information on SLG-2 via IO-Link

Table 3: Basic information via IO-Link with associated index

IO-Link Index	Object name	Description
16, 17, 18, 20, 21, 22, 23	Vendor Name, Vendor Text, Product Name, Product Text, Serial Number, Hardware Version, Firmware Version	Indices output different basic information of the light grid.
24	Application Specific Tag	A freely selectable name (e.g. name of the application) can be assigned.
64	Device specific tag	A freely selectable name (e.g. device name) can be assigned.
84	System properties	Retrieval of various system information such as response time, number of beams, beam separation, etc.
99	Teach-in necessary	Indicates when a teach-in is necessary
100	System status	Contains general diagnostic information such as error and/or warning message such as quality of run alarm, teach-in error, hardware error, etc.
204	Find me	Command that makes the LEDs of the SLG-2 receiver flash to make it easier to find in the system.
219	Product ID	Outputs the part number
480	Beam status (PDin)	Information about the status of each individual beam (object there or not). This information is the raw data of the SLG-2. It can be output via the process data or used for further processing.
481	Q_L/Q_{int} status	Outputs the Smart Task information Q_L 1-2 and the zone information Q_{int} 1-4.



NOTE

Detailed information on the subindices and access can be found in the IO-Link supplement (8389226).

7.5 General settings

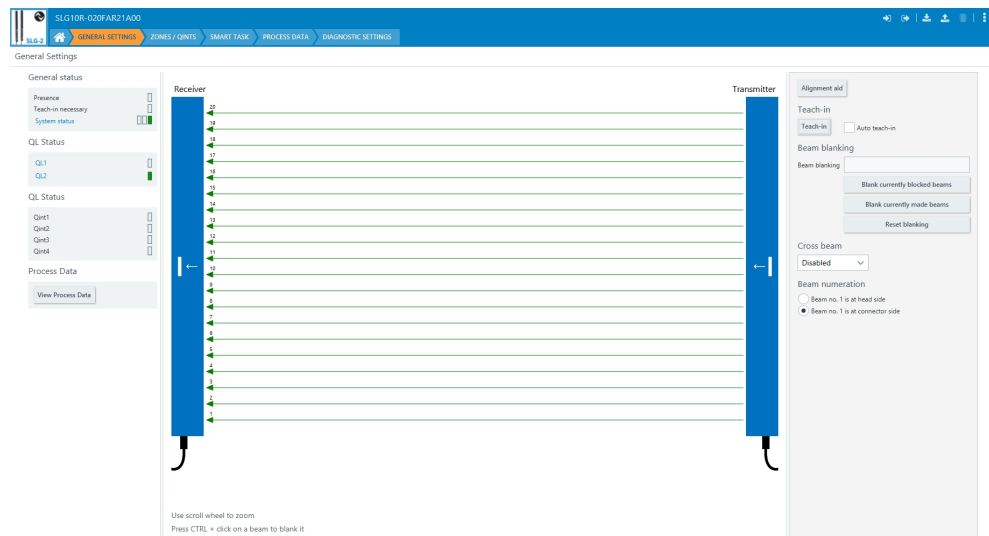

Figure 17: SOPAS - General settings tab

The following settings are possible in the **General settings** tab:

- **Switching threshold setting:** The SLG-2 receiver is set to an optimum switching threshold via the **Teach-in** to ensure reliable detection with sufficiently high resistance to contamination or other influences.
- **Alignment aid:** The **Alignment aid** function helps to optimally align the light grids (see "[Alignment aid via SOPAS ET](#)", page 28)
- **Auto teach-in:** A teach-in is performed automatically after connection to the voltage supply (see "[Auto teach-in](#)", page 23).
- **Beam blanking:** The **Beam blanking** can be used to blank beams that are not to be taken into account in the evaluation. This is useful if, for example, a static object is permanently blocking the light path. The following options are available:
 - **Beam blanking** by entering the beam number of the beam to be blanked
 - **Beam blanking** by right-clicking on the beam that is to be blanked
 - **Blank currently made beams** blanks all beams that are not blocked by an object during execution.
 - **Blank currently blocked beams** blanks all beams that are blocked by an object during execution.
 - **Reset blanking:** Switches all beams back to active
- **Cross beam:** The **Cross beam** function can be used to increase the resolution in certain ranges. For this purpose, a 3-fold and, for certain variants, also a 5-fold, 7-fold or 9-fold crossover is available. The amount of maximum possible crossover also depends on the distance between the sender and receiver. Detailed information on the cross-beam function can be found in [chapter 3.2.4](#).
- **Beam numeration:** The order of beam numbering can be changed. This also outputs the **Beam status** in a different order.
- **Beam number 1 is at connector side:** Beam numbering starts at the male connector side of the housing.
- **Beam number 1 is at head side:** Beam numbering starts at the front of the housing.

7.5.1 Alignment aid via SOPAS ET

With the **Alignment aid**, an alignment aid is available via IO-Link for precise alignment of the SLG-2 light grid (see "[General settings via IO-Link](#)", page 29). The values can be displayed graphically via SOPAS ET.

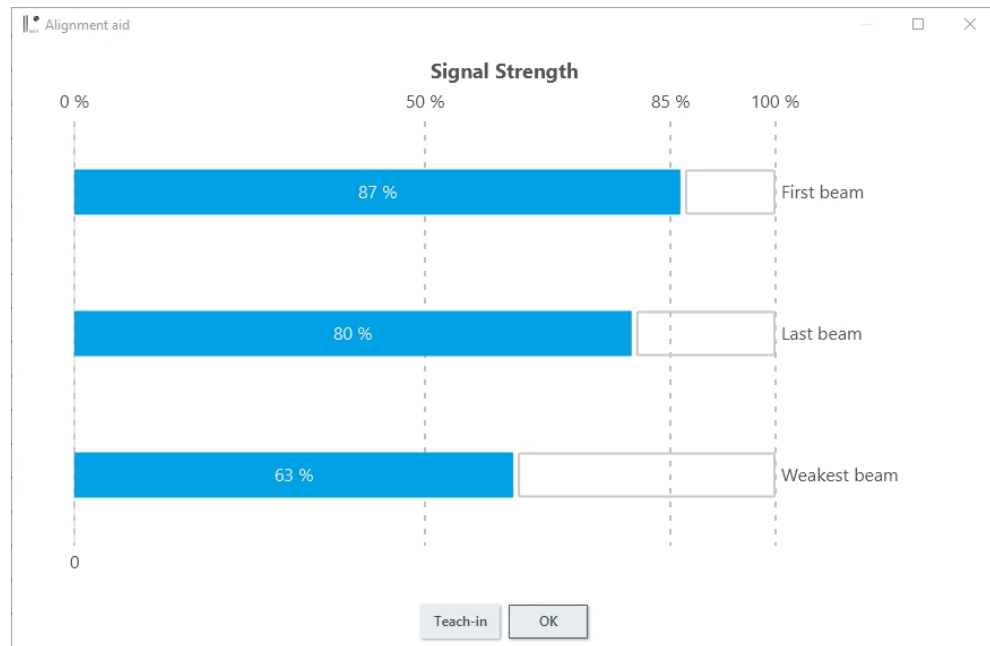

Figure 18: Graphical representation of **Alignment aid** in SOPAS ET

The **Alignment aid** shows the percentage signal level of the following beams:

- First beam not blanked
- Last beam not blanked
- Weakest non-blanked beam

The values of **Alignment aid** are to be interpreted as follows:

< 50%:	Insufficient signal strength for stable detection with operating reserve
50% - 85%:	Sufficient signal strength for stable detection with operating reserve
> 85%:	Optimal signal strength for stable detection with operating reserve

Aligning the SLG-2 light grid with the **Alignment aid** function:

1. Set up **Alignment aid** : For optimal function of the **Alignment aid**, move the light grid up and down until signal strength 0% is displayed on each side (first / last beam).
2. Align the sender and receiver with respect to each other until a value of at least 50% is reached for each beam shown in the **Alignment aid** .
3. Perform teach-in.

The **Alignment aid** is automatically deactivated for the following reasons:

- Teach-in command
- Restore factory settings
- IO-Link DataStorage download
- Hardware error



NOTE

When **Alignment aid** is active, the light grid cannot perform detection, it is not ready for operation. Process data and detection information are not transmitted. If the **Alignment aid** is active, the **Invalid process data** flag is set.

7.5.2 General settings via IO-Link

Table 4: General settings via IO-Link with associated index

IO-Link Index	Object name	Description
2	Standard Command 160 / Teach-In	Performs a teach-in

IO-Link Index	Object name	Description
2	Standard Command 208 / Blank all currently blocked beams	Blanks all currently blocked beams. Blanked beams are no longer taken into account in object detection.
2	Standard Command 209 / Blank all currently made beams	Blanks all currently free beams. Blanked beams are no longer taken into account in object detection.
66	Performance options	Cross beam can lead to an improvement in resolution. The height of the adjustable cross-over depends on the SLG-2 variant used.
69	Alignment aid enable	Activation or deactivation of the alignment aid. When the alignment aid is active, no process data or detection information is transmitted.
71	Auto teach-in	When activated: After connecting the voltage supply, a teach-in is performed automatically.
72	Beam mask	Individual blanking of individual beams. The blanked beams are not considered in the evaluation.
74	Beam numeration	Command changes the beam order: true = 1. Beam at front side false = 1. Beam at male connector side
109	Alignment aid	Displays the signal strength of the three beams relevant for alignment, each in a subindex. Values from 0-100 (percentages). Value 255 is displayed for a Hardware error .

**NOTE**

Detailed information on the subindices and access can be found in the IO-Link supplement (8389226).

7.6 Zones / Q_{ints}

In the **Zones/ Q_{int}** tab, it is possible to define several ranges or zones.

A maximum of 4 zones can be defined.

The zones are displayed in tabular form on the right side. You can parameterize the zones there. The zones are also shown in the system schematic (center).

Specific measurement functions can be defined within each zone. The result is passed on to an internal output state (Q_{int}), which in turn can be used for further functions (**SmartTask**). The Q_{int} status and measurement results of a zone can also be output via the serial interface (**Process data**).

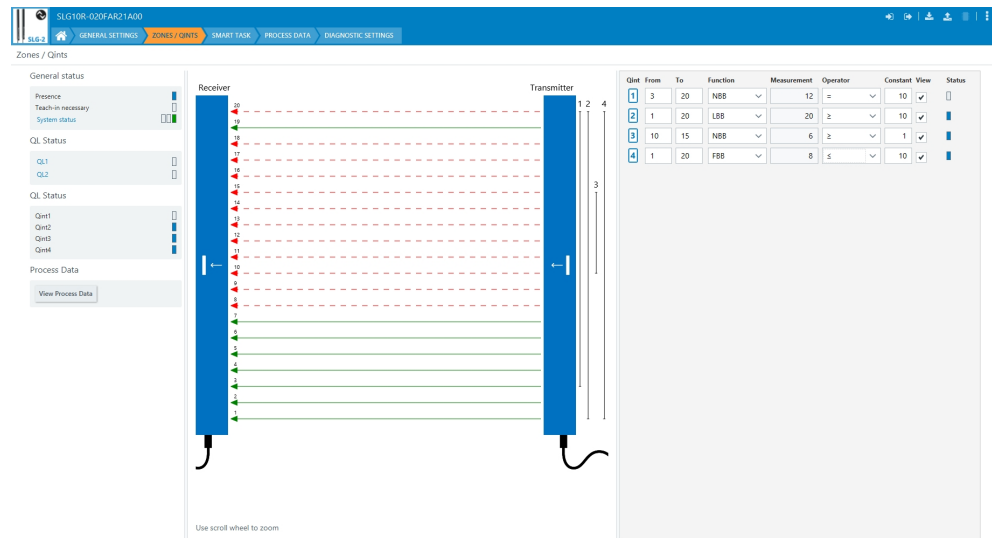

Figure 19: SOPAS tab Zones/Qints

You can individually select each zone in the right hand area of the screen and parameterize the zone. The Status column shows whether the internal output state Q_{int} is active or not.

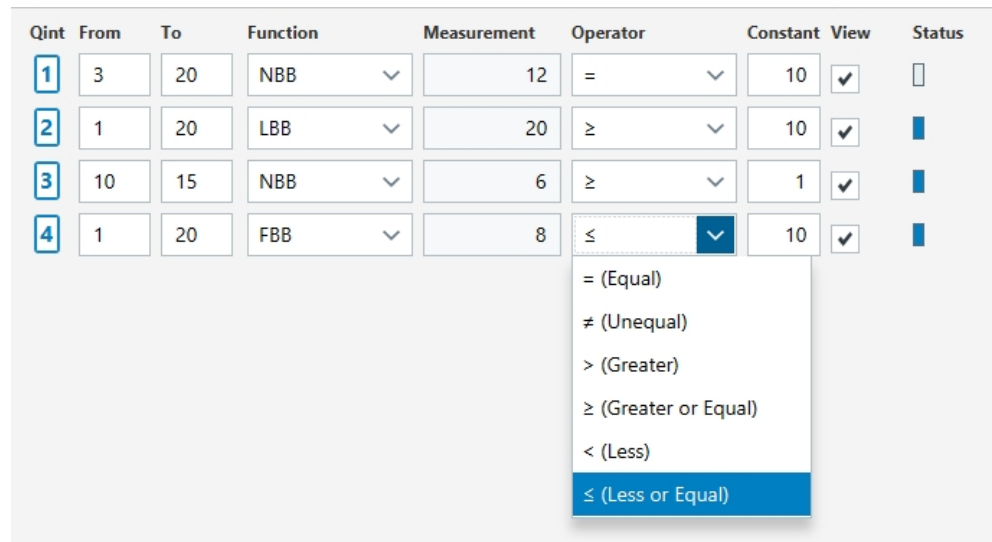

Figure 20: Overview of the zone configuration

The zone range can be set in the parameterization area (e.g. from beam 1 – beam 50). Furthermore, different measuring functions can be defined within a zone.

These include:

- NBB = Number of beams blocked; object detection or width classification
- FBB/LBB: First beam blocked / Last beam blocked: Mainly used for height measurement or height classification or for position determination.
 - FBB: Beam number of the first interrupted beam of a zone
 - LBB: Beam number of the last interrupted beam of a zone

Examples

Example 1 object detection with NBB:

Any object that interrupts at least one light beam should be detected.

$NBB \geq 1$ for object detection:

$Q_{int\ 3}$ active if at least 1 beam is interrupted

Example 2 width classification with NBB:

It should be detected when objects have the width of 10 light beams.

$NBB = 10$ for width classification:

$Q_{int\ 1}$ active if exactly 10 beams are interrupted in a zone

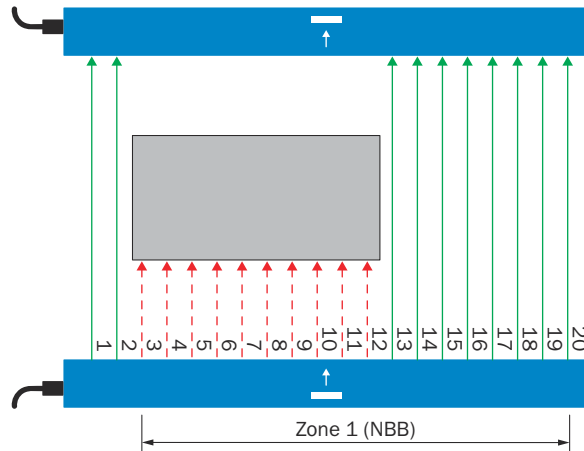

Figure 21: Width classification with NBB, example 2

Example 3 height classification with FBB:

Boxes above a certain size should be detected (large or larger than shown in the figure). The light grid is mounted from above (connection side at the top). The objects travel, for example, on a conveyor belt between the light grid.

$FBB \leq 10$:

If within zone 4 the first interrupted beam is 10 or lower, internal switching signal $Q_{int\ 4}$ is activated:

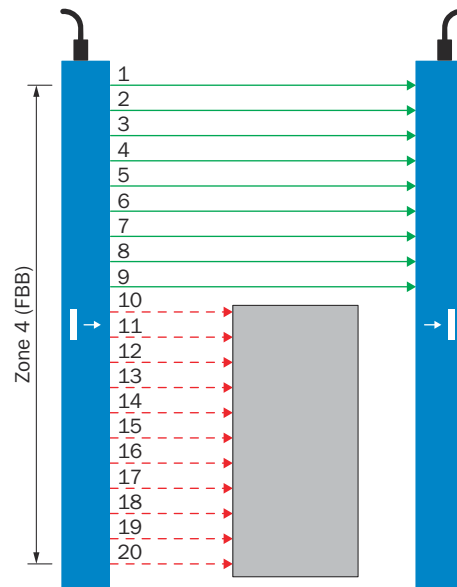

Figure 22: Height measurement with FBB, example 3

If a box is smaller than shown in the graphic, the first interrupted light beam is > 10 and internal switching signal $Q_{int\ 4}$ remains deactivated.

Example 4 height classification with LBB:

Boxes above a certain size should be detected (large or larger than shown in the figure). The light grid is mounted from below (connection side down). The objects travel, for example, on a conveyor belt between the light grid.

LBB ≥ 10:

If within zone 2 the last interrupted beam is 10 or greater, internal switching signal Q_{int2} is activated.

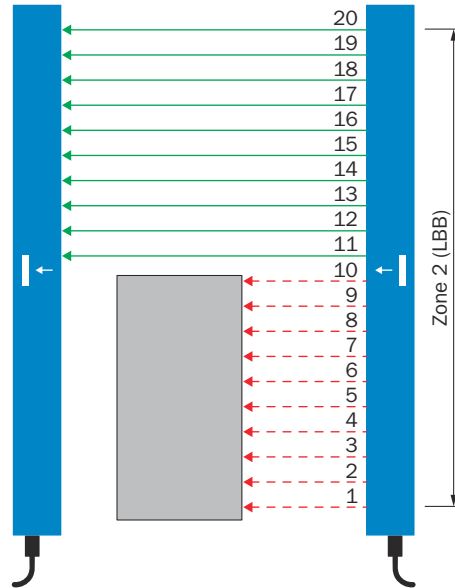

Figure 23: Height measurement with LBB, example 4

If a box is smaller than shown in the graphic, the first interrupted light beam is < 10 and the internal switching signal Q_{int2} remains deactivated.

Example 5 position determination with FBB:

The position of a box on a conveyor belt is to be detected. The light grids are mounted along a conveyor belt with the connection side on the left. The box moves from right to left. As soon as the box is in the position of the 10th light beam, the light grid switches.

FBB = 10:

If beam 10 is interrupted within zone 4, internal switching signal Q_{int2} is activated.

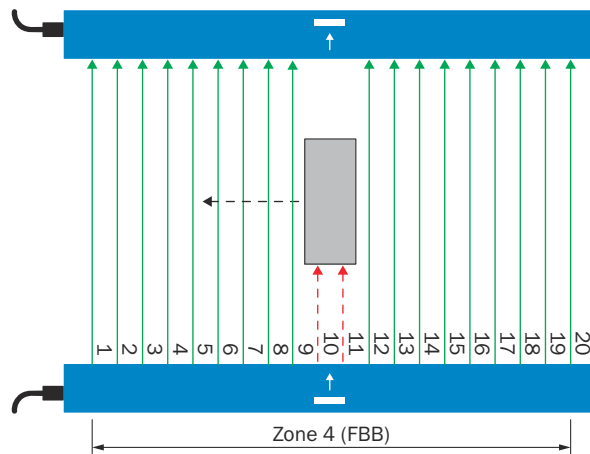

Figure 24: Position determination with FBB, example 5

Example 6 position determination with LBB:

The position of a box on a conveyor belt is to be detected. The light grids are mounted along a conveyor belt with the connection side on the left. The box moves from left to right. As soon as the box is in the position of the 10th light beam, the light grid switches.

LBB = 10:

If beam 10 is interrupted within zone 2, internal switching signal Q_{int2} is activated.

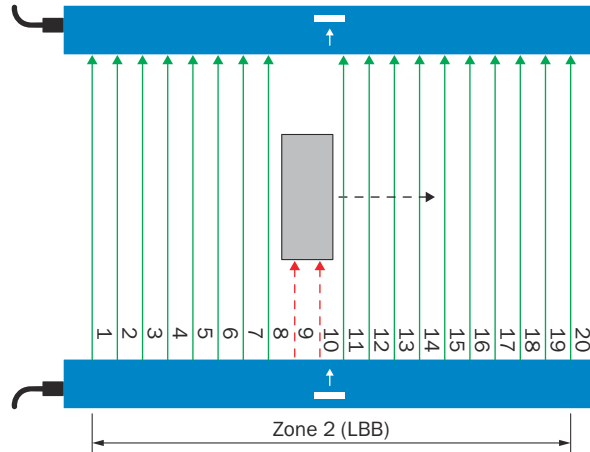

Figure 25: Position determination with LBB, example 6

7.6.1 Zones/ Q_{ints} via IO-Link

Table 5: Zones/ Q_{ints} via IO-Link with associated index

IO-Link Index	Object name	Description
351, 353, 355, 357	Q_{int} zone definition 1-4	Zone definition with one start beam and one end beam
352, 354, 356, 358	Q_{int} advanced settings 1-4	Definition of the LBB, FBB and NBB measurement function with operator and constant. The result (Q_{int}) is a boolean value.
481	Q_L / Q_{int} status	Outputs the Smart Task information Q_L 1-2 and the zone information Q_{int} 1-4.



NOTE

Detailed information on the subindices and access can be found in the IO-Link supplement (8389226).

7.7 Smart Task

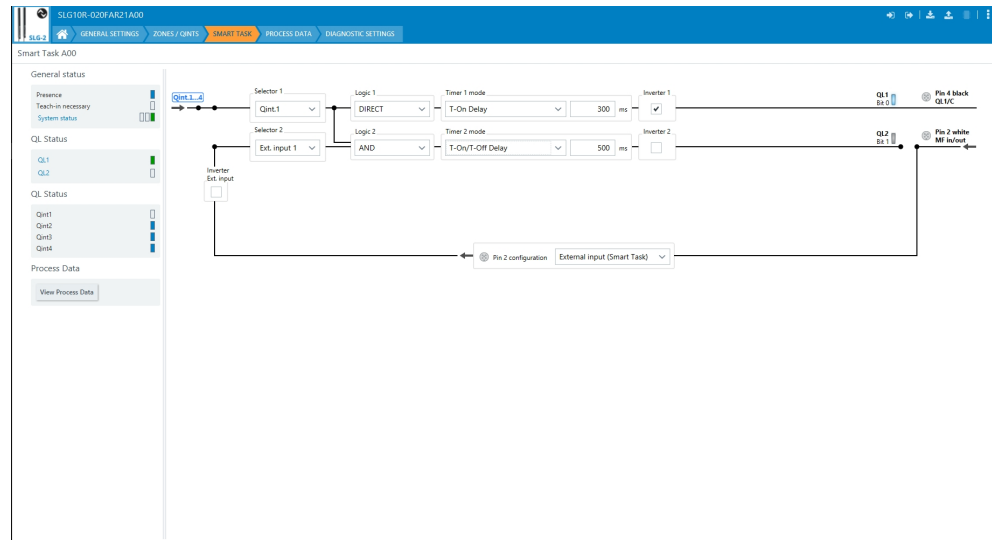

Figure 26: SOPAS - Smart Tasks tab

Using the **Smart Task** tab, the states of the individual zones ($Q_{int1} - Q_{int4}$) can be processed further and thus simple evaluations / size comparisons can be carried out. These Q_{int} states as well as an external input signal are possible input variables which are available for selection in the **Input selector** .

Via the settings for **Logic 1/2**, the input signal of **Input selector 1** can be logically linked with the input signal of **Input selector 2** . OR and AND logic gates are available for this purpose.

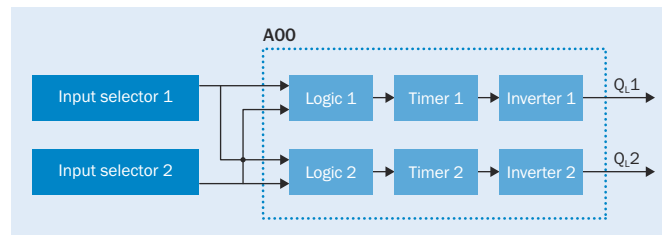

Figure 27: Logical principle of operation of the Smart Task function

Various delay modes can be selected via **Timer 1/2 mode** . The associated delay time is set via **Time 1/2 setup** . See the graph below for details on how the various modes work.

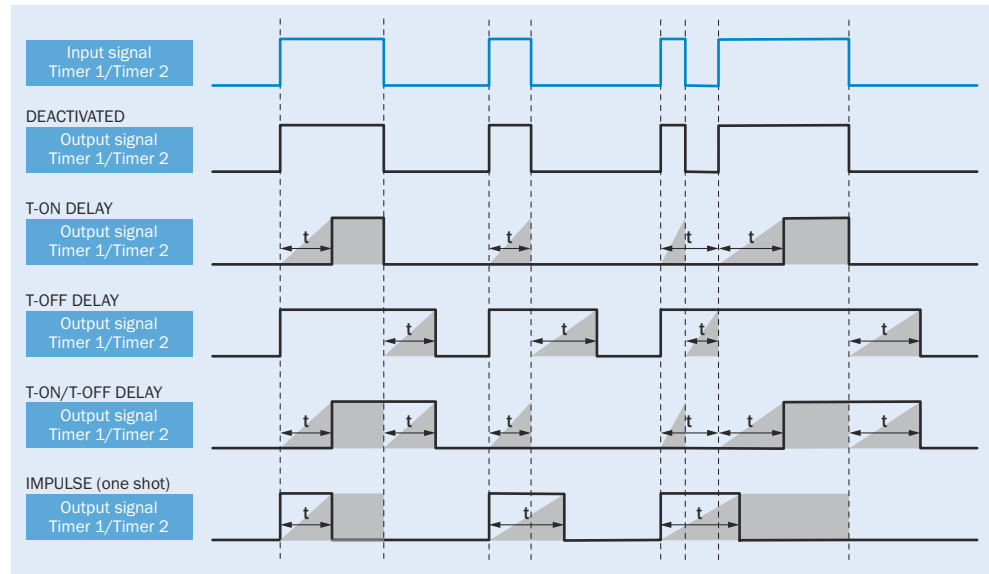

Figure 28: Mode of operation of time modes



NOTE

Inverting the **Timer 1/2** output signal does not affect how the delay modes work. Note that due to the inversion of the **Timer 1/2** output signal, a set switch-on delay, for example, can act like a switch-off delay.

Inverter 1/2 inverts the logic state of the **Timer 1/2** output signal.

Q_{L1} / Q_{L2} output the result of the **Smart Task**. The state of Q_{L1} is output via pin 4 (unless pin 4 is used as an IO-Link interface).

Pin 2 can output the Q_{L2} state or alternatively be configured for other purposes. Pin 4 is therefore also called MF (Multi Function). The following configuration is possible:

- **External input:** If pin 2 / MF is configured as **External input**, this is available for selection in **Input selector 1/2**
- **Blocked beams hold:** If the input signal is 1 ("HIGH"), the **Blocked beams hold** function is set. In this case, once interrupted, beams remain set or are held. Thus, only one status change of a beam from 0 to 1 is possible. This function is suitable, for example, to determine the highest point of an object.
If the input signal is 0 ("LOW"), the **Block beams hold** function is deactivated. The **Blocked beam hold** function is deactivated. The process data is no longer held.
- **Teach-in:** A teach-in can be performed via an input signal, see "[Commissioning](#)", page 23.
- **Switching signal Q_{L2} :** Output of Q_{L2} state via pin 2 / MF
- **Masked system status:** A selection of diagnostic information can be output via pin 2 / MF as an alarm signal output, see "[Diagnostic settings](#)", page 39.

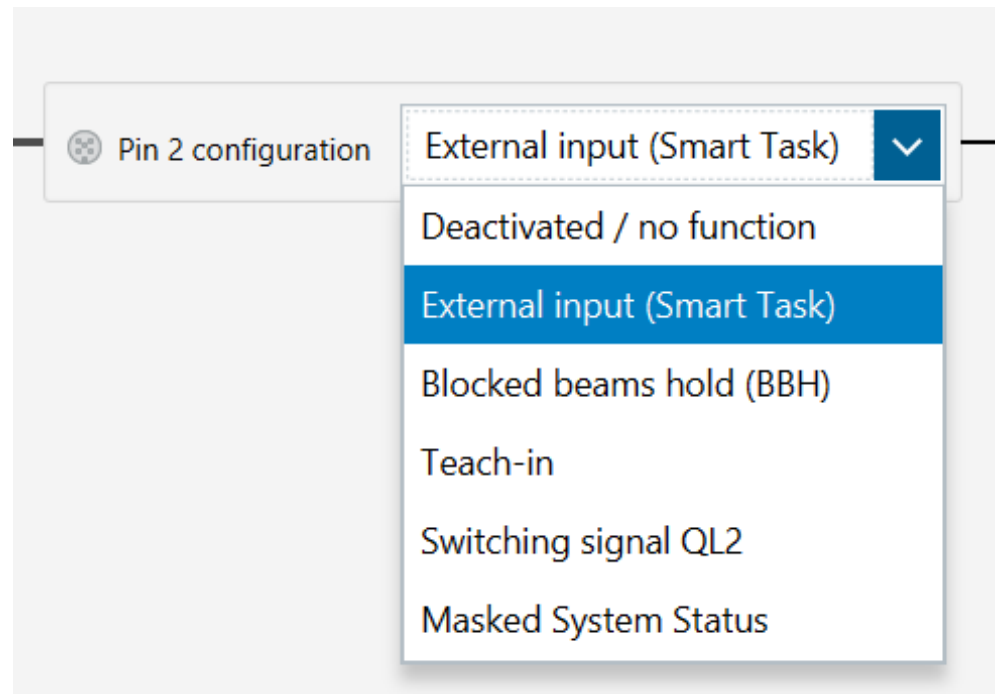

Figure 29: Possible pin 2 configurations

7.7.1 Smart Task via IO-Link

Table 6: Smart Task via IO-Link with associated index

IO-Link Index	Object name	Description
121	Pin 2 configuration	Configuration of pin 2 output or input function
481	Q_L / Q_{int} (PDin)	Outputs the Q_L / Q_{int} states.
1081	Input selector 1	Selection of zone values Q_{int1-4} or an external input signal Ext.-input 1 as logical input signal
1082	Input selector 2	Selection of zone values Q_{int1-4} or an external input signal Ext.-input 1 as logical input signal
1083	Logic 1	AND or OR logic to the possible input signals Q_{int1-4} or Ext.-input 1
1084	Logic 2	AND or OR logic to the possible input signals Q_{int1-4} or Ext.-input 1
1085	Timer 1 mode	Delay modes adjustable: T-On Delay , T-Off Delay , ...
1086	Timer 2 mode	Delay modes adjustable: T-On Delay , T-Off Delay , ...
1087	Time 1 setup	Delay values in ms can be set
1088	Time 2 setup	Delay values in ms can be set
1089	Inverter 1	Inverts the logic state of the Timer 1 output signal
1090	Inverter 2	Inverts the logic state of the Timer 2 output signal
1093	Inverter Ext.input	Inverts the external input signal



NOTE

Detailed information on the subindices and access can be found in the IO-Link supplement (8389226). For additional information on the Smart Task, refer to instructions 8022709, chapter 7.9.1.

7.8 Process data

Various output states as well as measurement and diagnostic information can be transmitted via IO-Link. The process data word has a length of 32 bytes. Each of these bytes can be individually populated with the desired data.

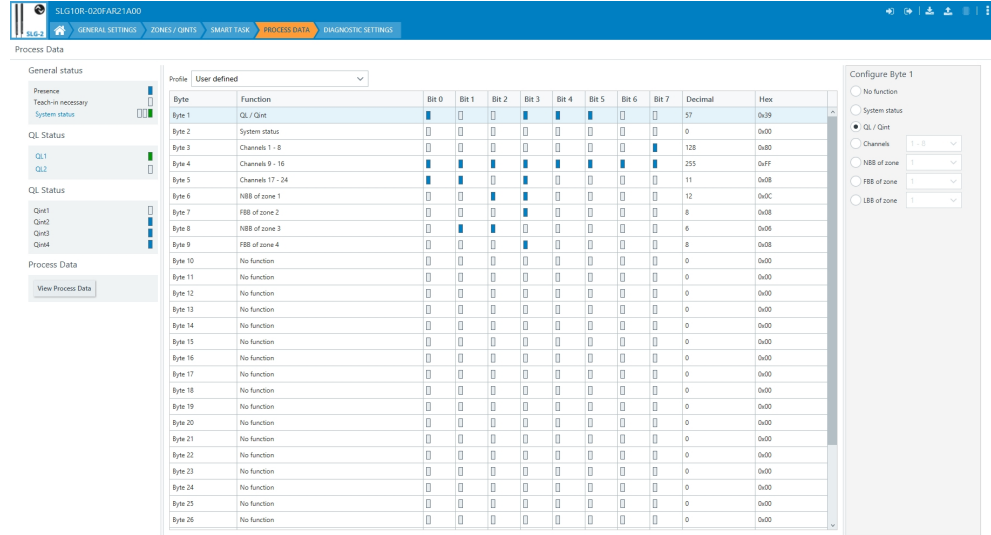

Figure 30: SOPAS – Process Data tab

Load process data via profiles (only available for SOPAS):

A number of pre-defined process data profiles are available that can be selected to populate the process data word. Common constellations are already stored for a simplified configuration.

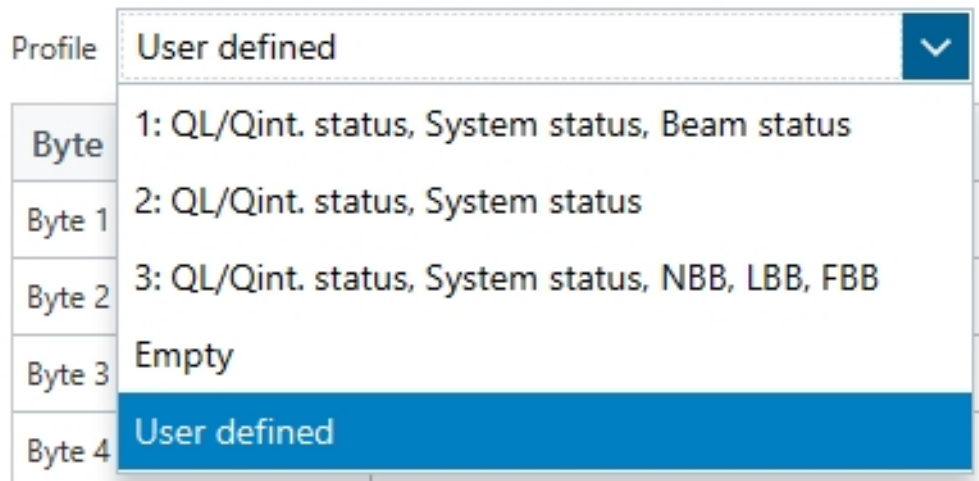

Figure 31: Load process data via profile.

7.8.1 Manually customizing the process data

Each individual byte of the process data can be customized. After clicking on a byte, a drop-down list of information that can be assigned to the byte is displayed. The length of each “information block” is limited to one byte (8 bits). A single byte can therefore be used, for example, to transmit 8 beam states.

NBB, FBB and LBB are the actual measured values. For example, NBB transmits how many light beams in the zone are blocked.

In addition, the Q_{int} status (states of zones 1-4) and the Q_L status (**Smart Task** states) can be transmitted via a byte.

The System Status is a diagnostic byte that transmits various diagnostic information, [chapter 7.2](#).

Figure 32: Process data word selection

7.8.2 Process Data via IO-Link

Table 7: Process data via IO-Link with associated index

IO-Link Index	Object name	Description
67	Process data user definition	Configuration of the process data. Each process data slot with a size of 8 bits can be assigned a process data function.
40	Process data input	Index for reading out the 32-byte process data via the service data channel



NOTE

Detailed information on the subindices and access can be found in the IO-Link supplement (8389226).

7.9 Diagnostic settings

Various diagnostic settings can be made in the **Settings** tab. These include:

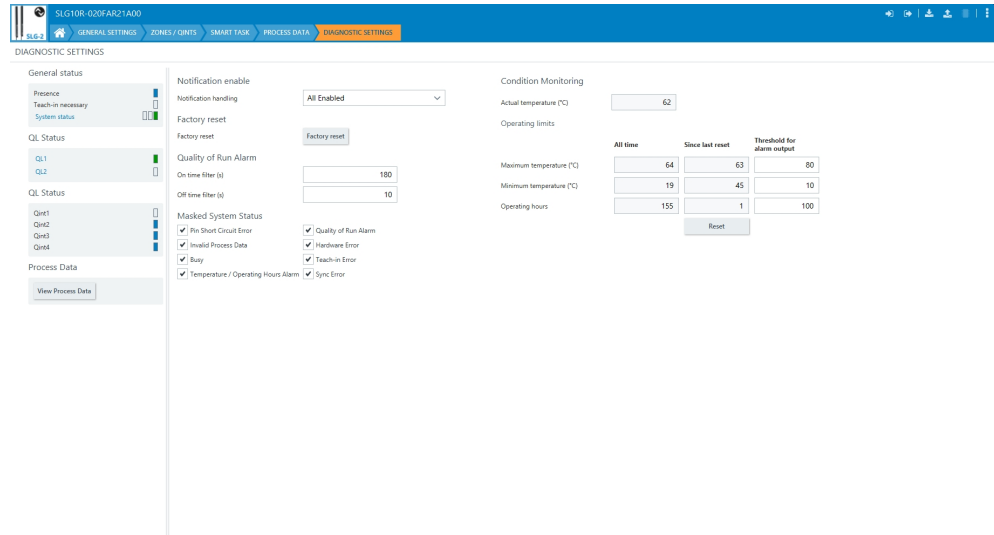
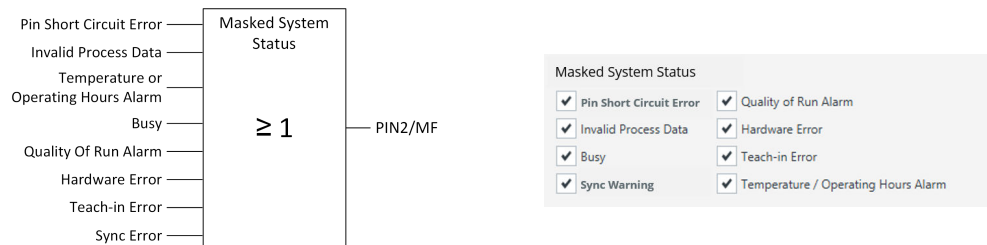

Figure 33: Diagnostic settings

- Events and IO-Link **PDisvalid** can be activated or deactivated via **Notification handling**. Various events such as overtemperature, overvoltage etc. are available, see IO supplement 8389226. **PDisvalid** means invalid process date.
- **Factory reset**: All settings are reset to the factory settings. Subsequent switching threshold setting via teach-in is necessary. Further settings may have to be made.
- **Quality of run alarm time-** filter: The filter can be used to select the time from which the **Quality of run alarm** signal becomes active. If the time is set very short, activation is possible if an object is in the light path for a longer time. Since the signal is mainly used to detect contamination, a time filter of several minutes is usually sufficient.
- **Masked system status**: A selection of diagnostic information can be output via an alarm signal output. It is an “OR” function of several diagnostic input signals which can be output as a binary signal via pin 2 / MF (see table 8). You can adjust or reduce the diagnostic information.

Table 8: Masked system status via pin 2 / MF output as bit information



- **Operating temperature diagnostic**: Output of the device temperature. Temperature changes can indicate changing ambient conditions, a defect in the device or in the application. Various temperature values are output and limits can be set:
 - **Temperature all time**: Maximum / minimum measured temperature since initial commissioning
 - **Temperature since last reset**: Maximum / minimum measured temperature since last **Temperature reset** commissioning

- **Temperature thresholds:** Highest / lowest permissible temperature limits can be set. If the temperature is exceeded or undercut, a warning signal is output (see "Diagnostics and troubleshooting", page 44).

**NOTE**

The device temperature is different from the ambient temperature. Since the temperature is only measured at one point inside the device, other temperatures may prevail at other points inside the device.

- **Operating hours diagnostics:** Output of the operating hours as well as parameterization option of operating hour limits:
 - **Total operating hours:** Total operating hours since initial commissioning
 - **Operating hours since last reset:** Operating hours since last reset
 - **Operating hours threshold:** Maximum permissible operating hours can be parameterized. If this value is exceeded, a warning signal is output (see "Diagnostics and troubleshooting", page 44).

Condition Monitoring

Actual temperature (°C)	<input type="text" value="59"/>		
Operating limits			
	All time	Since last reset	Threshold for alarm output
Maximum temperature (°C)	<input type="text" value="64"/>	<input type="text" value="63"/>	<input type="text" value="80"/>
Minimum temperature (°C)	<input type="text" value="19"/>	<input type="text" value="21"/>	<input type="text" value="-10"/>
Operating hours	<input type="text" value="221"/>	<input type="text" value="67"/>	<input type="text" value="100"/>
	<input type="button" value="Reset"/>		

Figure 34: Temperature values and temperature limits

7.9.1 Diagnostic settings via IO-Link

Table 9: Diagnostic settings via IO-Link with associated index

IO-Link Index	Object name	Description
2	System command 130 / Factory reset	All settings are reset to the factory settings.
2	Standard Command 228 / Reset diagnostic parameter	Resets the measured max/min temperatures (153) and the operating hours (190).
153	Current temperature	Outputs the current measured device temperature
153	Maximum temperature all time	Outputs the maximum measured temperature value
153	Minimum temperature all time	Outputs the minimum measured temperature value
153	Maximum temperature since last reset	Outputs the maximum measured temperature value since the last reset
153	Minimum temperature since last reset	Outputs the minimum measured temperature value since the last reset

IO-Link Index	Object name	Description
179	Upper temperature threshold	Defines the maximum temperature value above which a warning is to be issued
179	Lower temperature threshold	Defines the minimum temperature value below which a warning is to be issued
179	Operating hours threshold	Defines the maximum operating time from which a warning is to be issued
190	Total operating hours	Outputs the total operating time
190	Operating hours since last reset	Outputs the operating time since the last reset
227	Notification handling	Activating / deactivating of events and the IO-Link PDIinvalid (event codes on the last page of the IO-Link supplement)
311	Quality of run alarm on time filter	Setting a warning after a critical signal strength is detected at the sensor for the defined duration
312	Quality of run alarm off time filter	Resetting a warning after no reduced signal strength is detected at the sensor for the defined duration.
447	Pin 2 system status mask	Selection of diagnostic information that can be output via an OR function as a Boolean value via pin 2.

**NOTE**

Detailed information on the subindices and access can be found in the IO-Link supplement (8389226).

7.10 IO-Link specific settings

The SLG-2 light grids have an IO-Link interface. IO-Link enables the exchange of process, service and diagnostic data.

Configuration via acyclic service data

Functions such as zone definition, a teach-in or cross-beam option (**Cross beam** option) can be parameterized via the service data. The indices of the service data are listed in [chapter 7](#) and can be found in the IO-Link supplement. The IO-Link supplement can be found online for the respective product number. Various diagnostic information can be transmitted via the process data.

**NOTE**

Detailed information on the subindices and access can be found in the IO-Link supplement (8389226).

Data Storage

The **Data Storage** IO-Link function can be used to save all relevant parameters of the SLG-2 light grid in an IO-Link master. If the device is replaced, these parameters can be written to the new device, or they can be distributed to multiple other SLG-2 light grids with the same variant and with the same application.



NOTE

After a **Data Storage** download, the **Teach-in status** of the SLG-2 light grid is reset. This means that a teach-in is necessary. If **Auto teach-in** is set, the teach-in is performed automatically on restart.

Process data output

Transmission data

- Minimum cycle time of IO-Link: 2.3 ms
- Baud rate: COM3 (230.4 kbaud)
- Process data length: 32 bytes
- IO-Link version: 1.1.0

8 Diagnostics and troubleshooting

8.1 IO-Link specific diagnostic information

8.1.1 Device Status

General diagnostic information is available via IO-Link through the **Device Status** object. **Device Status** information (e.g. **Maintenance required**) can have several causes (e.g. **Quality of run alarm** or **Teach-in error**) (see table 11).

Table 10: IO-Link **Device Status**

IO-Link Index	Object name	Description
36	Device Status	Provides information about the general state of the light grid

Table 11: Values in the **Device Status**

Value = priority ascending	Definition	Event (System Status)
0	Device is in order	-
1	Maintenance required	Quality of run alarm, Temperature or Operating hours alarm, Teach-in error, Teach-in necessary
2	Out of specification	Not in use
3	Functional check	Busy, Sync error
4	Failure	Hardware error, Pin short circuit error



NOTE

Detailed information on the subindices and access can be found in the IO-Link supplement (8389226).

8.1.2 Events

In addition to **Device Status**, the IO-Link interface provides events for fault diagnosis. Detailed information can be found in the IO-Link supplement. The following information is available as events:

Table 12: Events available

Code dex (hex)	Event name	Type
20480 (0x5000)	Device hardware fault	Error
30480 (0x7710)	short-circuit	Error
36004 (0x8CA4)	Quality of run alarm	Warning
36007 (0x8CA7)	Teach-in error	Warning
36008 (0x8CA8)	Alarm upper temperature threshold	Warning
36011 (0x8CAB)	Alarm operating hours	Warning
36015 (0x8CAF)	Alarm lower temperature threshold	Warning
36017 (0x8CB1)	Teach-in necessary	Note
36033 (0x8CC1)	Sync error	Warning

8.1.3 Detailed Device Status

The **Detailed Device Status** is a list of currently pending events. The list represents 8 events (maximum number of SLG-2 events). Each entry has a length of 3 bytes or 3 octets and contains information about the event type (contained via the **Event Qualifier**) as well as about the **Event Code**. The last event that occurred is always at index 1 (dynamic list).

Table 13: IO-Link index of the *Detailed Device Status*

IO-Link Index	Object name	Description
37	Detailed device status	List of current IO-Link events

Table 14: Subindex of the *Detailed Device Status*

Sub-index	Object name	Data type	Description
1	Error_Warning_1	3 octets	All octets 0x00: No Error / Warning Octet 1: Event Qualifier Octet 2, 3 Event Code
2	Error_Warning_2	3 octets	
3	Error_Warning_3	3 octets	
4	Error_Warning_4	3 octets	
...			
n	Error_Warning_n	3 octets	

The following states are available as event qualifiers:

Table 15: *Event Qualifier*

Event Qualifier	am	dec	hex
Warning disappear	10100100	164	A4
Error disappear	10110100	180	B4
Warning appear	11100100	228	E4
Error appear	11110100	244	F4

8.2 Device-specific diagnostic information

In addition to the IO-Link-specific diagnostic information, additional diagnostic information about the process or service data can be transmitted via the **System status** as well as limited via pin 2 with the **Masked system status output** option. In addition, SOPAS ET offers a user-friendly display of this diagnostic information.

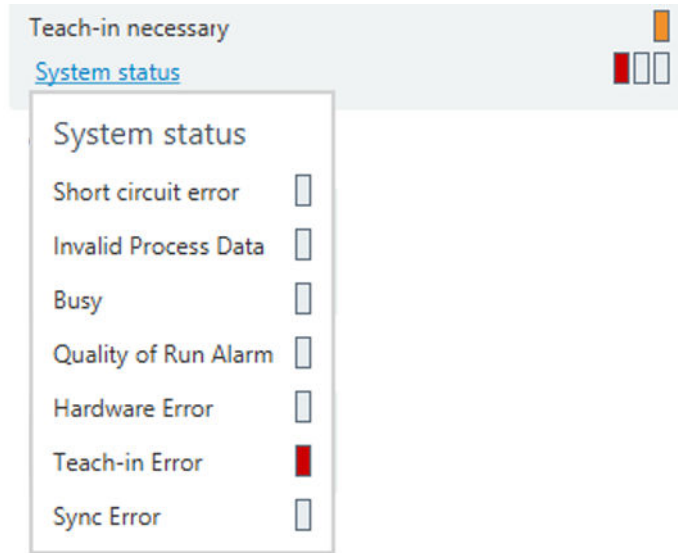

Figure 35: System status in SOPAS

The system status contains device-specific diagnostic information and has a length of one byte. Each bit represents different diagnostic information.

Table 16: IO-Link index of device-specific diagnostic information

IO-Link Index	Object name	Description
100	System status	Device-specific diagnostic information transmittable via the process data

Table 17: Bits of the device-specific diagnostic information

Bit number	System status	Type
Bit 0	Pin short circuit error	Error
Bit 1	Invalid process data	Error
Bit 2	Temperature or operating hours alarm	Warning
Bit 3	Busy	Note
Bit 4	Quality of run alarm	Warning
Bit 5	Hardware error	Error
Bit 6	Teach-in error	Error (a warning in IO-Link Events)
Bit 7	Sync error	Error (a warning in IO-Link Events)

The system status can be transmitted cyclically via the process data. Configuration of the process data is described in [chapter 7.8](#).

In addition, the **System status** information can also be transmitted as a 1-bit value “OR” function via pin 2 / MF. A selection of diagnostic information relevant for the application is possible here (see ["Diagnostic settings", page 39](#)).

8.3 Diagnostic information via the display LEDs

Three different diagnostic classes are available as diagnostic information via the display:

Table 18: Diagnostic classes and display behavior

Diagnostic class	LED
About	1 Hz
Warning	2 Hz
Error	8 Hz

The states are represented as follows:



NOTE

All messages are relevant only to the recipient, with the exception of **Test input enable**, **Power on** and **Hardware error**.

Table 19: LED display depending on device status

Message	Details	Class	Yellow LED	Green LED
Power on	-	About	Not relevant	On
Presence / no presence	Independent of the pin configuration	About	Off \geq 1 beam interrupted On = no beam interrupted	On
Busy	Device startup, Teach-in, Factory reset, Reconfiguration cross beam, IO-Link data storage download	About	1 Hz; 50% duty	On
Find me	In the FindMe function, both LEDs on the receiver flash.	About	1 Hz; 50% duty	1 Hz; 50% duty
IO-Link communication	-	About	Not relevant	1 Hz; 90% on; 10% off
Test input enable	If a HIGH signal is applied to sender pin 2, the sender LEDs are deactivated (sender only).	About	1 Hz; 50% duty	On
Quality of run (QoR) alarm warning	LED only flashes if no object is in the beam path	Warning	2 Hz; 50% duty	On
Temperature or operating hours alarm	-	Warning	2 Hz; 50% duty	On
Alignment aid	If alignment aid is activated via index 69 or SOPAS.	Warning	2 Hz; 50% duty	On
Teach-in error	\leq 5 seconds active. According to a power cycle, a Teach-in error becomes a Teach-in necessary	Error	8 Hz; 50% duty	On
Short circuit error	-	Error	8 Hz; 50% duty	On
Sync error	If first and last beam interrupted at the same time	Error	8 Hz; 50% duty	On
Hardware error	-	Error	Off	Off

8.4 Sync error

To ensure reliable detection with the specified resolution, only one beam at a time is active on the light grid. The beams are clocked through in the μ s range.

To ensure that the sender beam and the receiver beam adjacent on the same plane are always active, the beams must be synchronized with each other.

With the SLG-2 light grid, this happens optically via beam 1 and the last beam (starting from the cable). If both synchronization beams are interrupted at the same time, a **Sync error** is displayed as the diagnosis. In this state, the SLG-2 light grid can perform detection, but it can no longer detect which beams are interrupted.

In this mode, object measurement (**Beam status**, height, width...) is no longer possible. For measuring tasks, it must therefore be ensured that one of the two sync beams is free during the measurement process.

8.5 Troubleshooting

LED indicator/fault pattern	Cause	Measure
Yellow LED does not light up, no object in the path of the beam	Distance between sender and receiver is too large: Sender and receiver not aligned correctly.	Check application. Align the sender with the receiver and teach in. Alignment aid is available, chapter 7.5.1 .
Yellow LED lights up, although an object is in the path of the beam.	Object too small or is reflected and diverted away or is translucent.	Check application, opaque object? Where applicable, remove the cause of the reflection Start teach-in process again
Yellow LED flashes at 8 Hz for ≤ 5 s.	Teach-in faulty	Check application Align the sender with the receiver and teach in.
Yellow LED flashes at 8 Hz for as long as an object is located in the optical path.	Object is blocking all beams.	Ensure that the last or first beam is always unobstructed (this is only relevant for measuring applications).
Yellow LED flashes at 2 Hz for as long as no object is located in the optical path.	Device is dirty or poorly aligned.	Clean sender and receiver with plastic cleaner and / or align. Restart teach process
Yellow LED flashes at an undefined frequency even though an object is in the optical path	Interference with an adjacent sensor	Swap the arrangement of the sender and receiver Restart teach process
Yellow LED flashes at 8 Hz for > 5 s, no object in the beam path		Check cabling (short circuit).
Both LEDs do not light up.	No voltage supply	Perform Power cycle . If the error is still present, contact customer service.

9 Maintenance

9.1 Maintenance

During operation, the device works maintenance-free.

Depending on the assignment location, the following preventive maintenance tasks may be required for the device at regular intervals:

Table 20: Maintenance schedule

Maintenance work	Interval	Implementation
Clean housing and front screen	Cleaning interval depends on ambient conditions and climate	Specialist
Check screw connections and plug connectors	Every 6 months	Specialist

10 Decommissioning

10.1 Disassembly and disposal

Disassembling the device

1. Switch off the supply voltage to the device.
2. Detach all connecting cables from the device.
3. If the device is being replaced, mark its position and alignment on the bracket or surroundings.
4. Detach the device from the bracket.

Disposing of the device

Any device which can no longer be used must be disposed of in an environmentally friendly manner in accordance with the applicable country-specific waste disposal regulations.



NOTE

Disposal of batteries, electric and electronic devices

- According to international directives, batteries, accumulators and electrical or electronic devices must not be disposed of in general waste.
- The owner is obliged by law to return this devices at the end of their life to the respective public collection points.



 This symbol on the product, its package or in this document, indicates that a product is subject to these regulations.

10.2 Returning devices

- ▶ Do not dispatch devices to the SICK Service department without consultation.



NOTE

To enable efficient processing and allow us to determine the cause quickly, please include the following when making a return:

- Details of the contact person
 - Description of the application
 - Description of the fault that occurred
-

11 Technical data

Features

Table 21: Features

Type	SLGxxx-xxxxAxxxx	SLGxxx-xxxxCxxxxxx	SLGxxx-xxxxExxxxxx
Principle of operation	Light grid with sender and receiver		
Sensing range (minimum ... maximum)	150 mm ... 4,900 mm	150 mm ... 2,400 mm	60 mm ... 2,150 mm
Parallel-beam mode (recommended)	440 mm ... 3,500 mm	440 mm ... 1,700 mm	70 mm ... 1,500 mm
3 x cross-beam mode (recommended)	440 mm ... 3,500 mm	440 mm ... 1,700 mm	SLG10x: 70 mm ... 1,500 mm SLG25x: 160 mm ... 1,500 mm SLG50x: 320 mm ... 1,500 mm
5 x cross-beam mode (recommended)	SLG10x / SLG25x: 440 mm ... 3,500 mm SLG50x: 630 mm ... 3,500 mm	SLG10x / SLG25x: 440 mm ... 1,700 mm SLG50x: 630 mm ... 1,700 mm	SLG10x: 130 mm ... 1,500 mm SLG25x: 320 mm ... 1,500 mm SLG50x: 630 mm ... 1,500 mm
7 x cross-beam mode (recommended)	SLG10x: 440 mm ... 3,500 mm SLG25x: 470 mm ... 3,500 mm SLG50x: 950 mm ... 3,500 mm	SLG10x: 440 mm ... 1,700 mm SLG25x: 470 mm ... 1,700 mm SLG50x: 950 mm ... 1,700 mm	SLG10x: 190 mm ... 1,500 mm SLG25x: 470 mm ... 1,500 mm SLG50x: 950 mm ... 1,500 mm
mm cross-beam mode (recommended)	SLG10x: 440 mm ... 3,500 mm SLG25x: 630 mm ... 3,500 mm SLG50x: 1,260 mm ... 3,500 mm	SLG10x: 440 mm ... 1,700 mm SLG25x: 630 mm ... 1,700 mm SLG50x: 1,260 mm ... 1,700 mm	SLG10x: 250 mm ... 1,500 mm SLG25x: 630 mm ... 1,500 mm SLG50x: 1,260 mm ... 1,500 mm
Beam separation	SLG10x-xxxxxxxxxx: 10 mm SLG25x-xxxxxxxxxx: 25 mm SLG50x-xxxxxxxxxx: 50 mm		
Detection height	100 mm - 2,400 mm Up to 800 mm (increment 100 mm) From 800 mm (increment 200 mm)		
Optical light emission	Slim / Flat		
Synchronization	Optical		

Type	SLGxxx-xxxxAxxx	SLGxxx-xxxxCxxxxx	SLGxxx-xxxxExxxxx
Number of beams	2 - 240 beams		
Light source			
Type of light	Infrared light		
Wavelength	850 nm		
Parameterization interface	Pin 2 / MF (teach-in) IO-Link		

Table 22: Time response

Type	SLGxxS-xxxxRxxA00 SLGxxS-xxxxRxxD0x SLGxxS-xxxxRxxD1x	SLGxxS-xxxxRxxD2x SLGxxS-xxxxRxxD3x SLGxxS-xxxxRxxD4x
Initialization time	0,4 s ... 2 s ¹⁾	
Teach-in time	0,75 ... 24 s ¹⁾	
Scan time (parallel beam)	0,041 ms * number of beams + 0,5 ms ²⁾	0,041 ms * number of beams + 0,75 ms ²⁾
Scan time (cross beam)	2 * (0,041 ms * number of beams + 0,5 ms) ³⁾	2 * (0,041 ms * number of beams + 0,75 ms) ³⁾
Repeatability (parallel beam)	scanning time	
Repeatability (cross beam)	1.5 * scan time	
Minimum dwell time	2 * scan time	
Max. response time (parallel beam)	3 * scan time + 0,015 ms * number of beams - 0,25 ms	
Max. response time (cross beam)	2.5 * scan time + 0,048 ms * number of beams + 0,6 ms	
Offset after loss of optical synchronization	≤ 10 beams: 6 * scan time ≤ 40 beams: 4 * scan time >40 beams: 2 * scan time	

- 1) Depending on the installed working distance / number of beams / cross-beam setting
- 2) Minimum scan time (parallel beam) = 1 ms
- 3) Minimum scan time (cross beam) = 2 ms

Electrical data

Table 23: Electrical data

Power consumption of sender @ 24 V		
Sender	≤ 0,075 mA x number of beams + 35 mA	
Receiver	≤ 0,6 mA x number of beams + 39 mA ¹⁾	
Supply voltage (U _B)	DC 18 ... 30 V	
Switching output/inputs	2 outputs: Q _{L1} , Q _{L2} (MF) 1 Input: MF	
Output current per switching output I _{max}	100 mA	
Capacitive output load	100 nF max.	
Inductive output load	1 H max.	
Logic level		
Input:	HIGH > 15 V LOW < 5 V	
Output:	HIGH _{VS} > U _B - 3 V LOW _{VS} < 3 V	

Protection class	
Circuit protection	U _V connections reverse polarity protected Output Q short-circuit protected Output Q overload protected

1) without load

Mechanical data

Table 24: Mechanical data

Connection type	M8, M12
Cable diameter	Ø 3.4 mm
Cable cross-section	AWG26, 0.14 mm ²
Housing material	Aluminum and plastic PMMA
Overvoltage protection	1 A
Weight	30 g + 530 g * housing length

Communication interface

Table 25: Communication interface

IO-Link	V1.1
Data transmission rate	230.4 mm/s (COM3)
Cycle time	≤ 2.3 ms
Process data length	32 Bytes
Process data structure	Each byte configurable Factory setting depending on type code
Maximum length of cable	20 m

Ambient environment

Table 26: Ambient environment

Enclosure rating	IP65, IP67
Electromagnetic compatibility	EN 61000-6-2
EMC radiated emission	EN 61000-6-4
Ambient temperature, operation	-25 °C ... +55 °C
Ambient temperature, storage	-25 °C ... +70 °C
Ambient light immunity	SLGxxx-xxxxAxxxxxx / SLGxxx-xxxxBxxxxxx: 30,000 lx direct sunlight SLGxxx-xxxxCxxxxxx: 100,000 lx direct sunlight
Vibration resistance	Sine wave: 10-150 Hz, 0.35 mm IEC 60068-2-6
Shock resistance	Single shocks: 15 g, 16 ms Continuous shocks (500 per axis): 10 g, 16 ms DIN EN 60068-2-27

Smart Task

Table 27: Smart Task

Smart Task designation	Basic logic
Logic function	Direct, AND, OR

Timer function	Deactivated Switch-on delay Switch-off delay Switch-on and -off delay Pulse (One Shot)
Inverter	✓
Switching signal Q _{L1}	Switching output
Switching signal Q _{L2}	Switching output

11.1 Resolution

To determine the resolution, 3 essential parameters have to be distinguished:

MDO: Minimum detectable object = minimum object size

MOL: Minimum object length

MOW: Minimum object width (only relevant in cross-beam mode)

The minimum object size differs between parallel-beam mode and cross-beam mode.

Description, [chapter 3.2.4](#).

11.1.1 Minimum object size (MDO)

Parallel operation

Table 28: MDO in parallel-beam mode

Beam separation	Minimum object size (MDO)
10 mm	15 mm
25 mm	30 mm
50 mm	55 mm

Cross-beam mode

A description of cross-beam mode can be found in [chapter 3.2.4](#).

In cross-beam mode, the MDO depends on the beam separation, the cross-beam option and the object position between the sender and receiver. The following graphic serves for a better understanding:

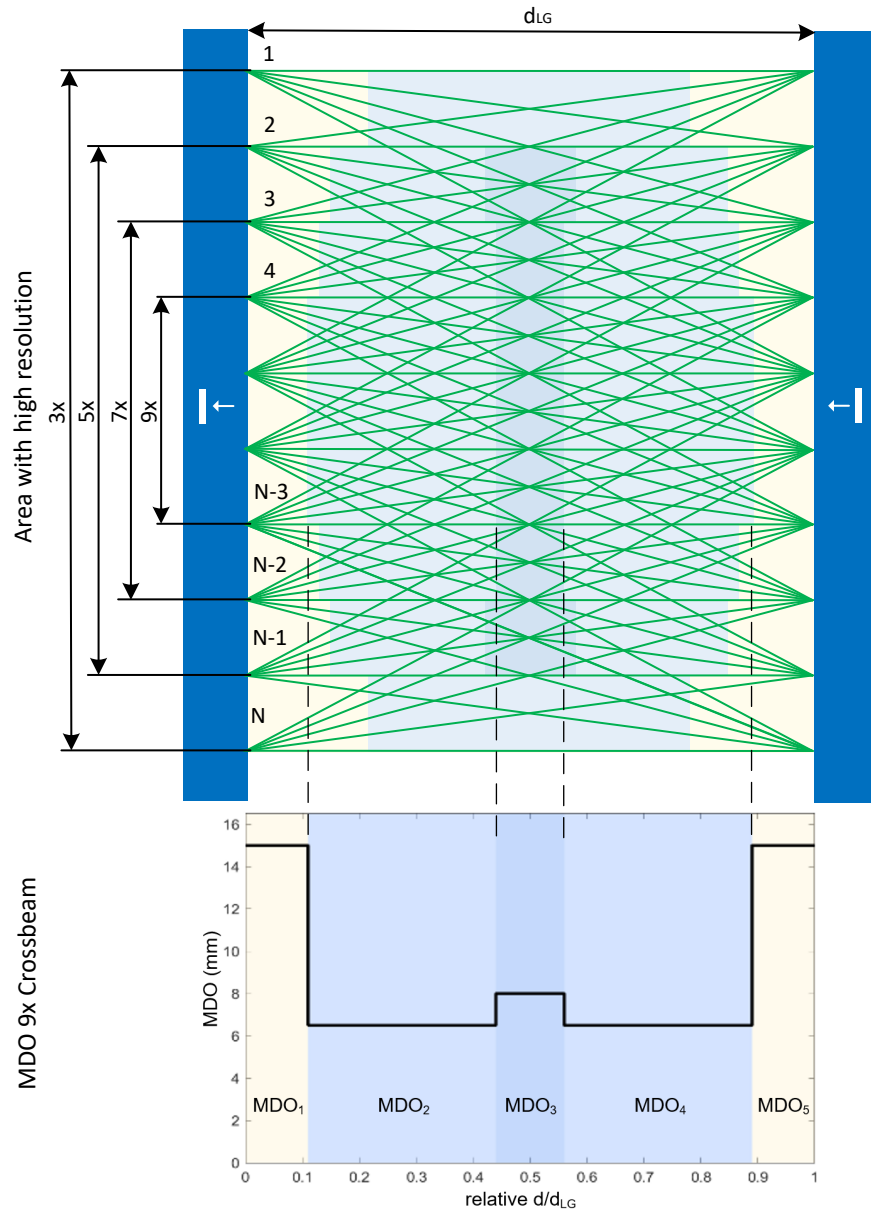

Figure 36: MDO: Example of a light grid with 10-mm beam separation and the set 9x cross-beam option

For the 9x cross-beam option, the MDO for a device with 10-mm beam separation is equal to 8 mm in the MDO3 range and 6.5 mm in the MDO2 and MDO4 ranges. In the MDO1 and MDO5 range, the MDO is 15 mm, as in parallel-beam operation.

It should be noted that the 9x intersection is achieved only in the middle region of the vertical light grid length (from beam 4 to beam N-3). After that, the cross-beam option decreases by one option per beam.

The MDOx ranges are relative indications. In this example, if the light grid has a working distance of 1,000 mm, the MDO3 range is 120 mm and MDO2 and MDO4 ranges are 330 mm each. If the light grids are spaced twice, the MDOx range is also doubled.

The higher the set cross-beam option, the greater the range of better resolution due to crossed beams between the sender and receiver (MDO2 – MDO4). The table below contains the MDO data depending on the set cross-beam option and the beam separation of each individual range.

Table 29: MDO depending on the beam separation, the cross-beam setting as well as the position of the object

Beam separation	3x	5x	7x	9x
10 mm	MD01 = 15.0 mm MD02 = 9.0 mm MD03 = 15.0 mm	MD01 = 15.0 mm MD02 = 7.5 mm MD03 = 8.0 mm MD04 = 7.5 mm MD05 = 15.0 mm	MD01 = 15.0 mm MD02 = 7.0 mm MD03 = 8.0 mm MD04 = 7.0 mm MD05 = 15.0 mm	MD01 = 15.0 mm MD02 = 6.5 mm MD03 = 8.0 mm MD04 = 6.5 mm MD05 = 15.0 mm
25 mm	MD01 = 30.0 mm MD02 = 16.5 mm MD03 = 30.0 mm	MD01 = 30.0 mm MD02 = 12.5 mm MD03 = 15.5 mm MD04 = 12.5 mm MD05 = 30.0 mm	MD01 = 30.0 mm MD02 = 12.0 mm MD03 = 15.5 mm MD04 = 12.0 mm MD05 = 30.0 mm	MD01 = 30.0 mm MD02 = 11.5 mm MD03 = 15.5 mm MD04 = 11.5 mm MD05 = 30.0 mm
50 mm	MD01 = 55.0 mm MD02 = 29.0 mm MD03 = 55.0 mm	MD01 = 55.0 mm MD02 = 21.0 mm MD03 = 28.0 mm MD04 = 21.0 mm MD05 = 55.0 mm	MD01 = 55.0 mm MD02 = 20.5 mm MD03 = 28.0 mm MD04 = 20.5 mm MD05 = 55.0 mm	MD01 = 55.0 mm MD02 = 20.0 mm MD03 = 28.0 mm MD04 = 20.0 mm MD05 = 55.0 mm
MD02 range MD03 range MD04 range MD02 – MD04 range	0.30 - 0.70 d_{LG} - - 40%	0.20 - 0.42 d_{LG} 0.42 - 0.58 d_{LG} 0.58 - 0.80 d_{LG} 60%	0.14 - 0.44 d_{LG} 0.44 - 0.56 d_{LG} 0.56 - 0.86 d_{LG} 72%	0.11 - 0.44 d_{LG} 0.44 - 0.56 d_{LG} 0.56 - 0.89 d_{LG} 78%

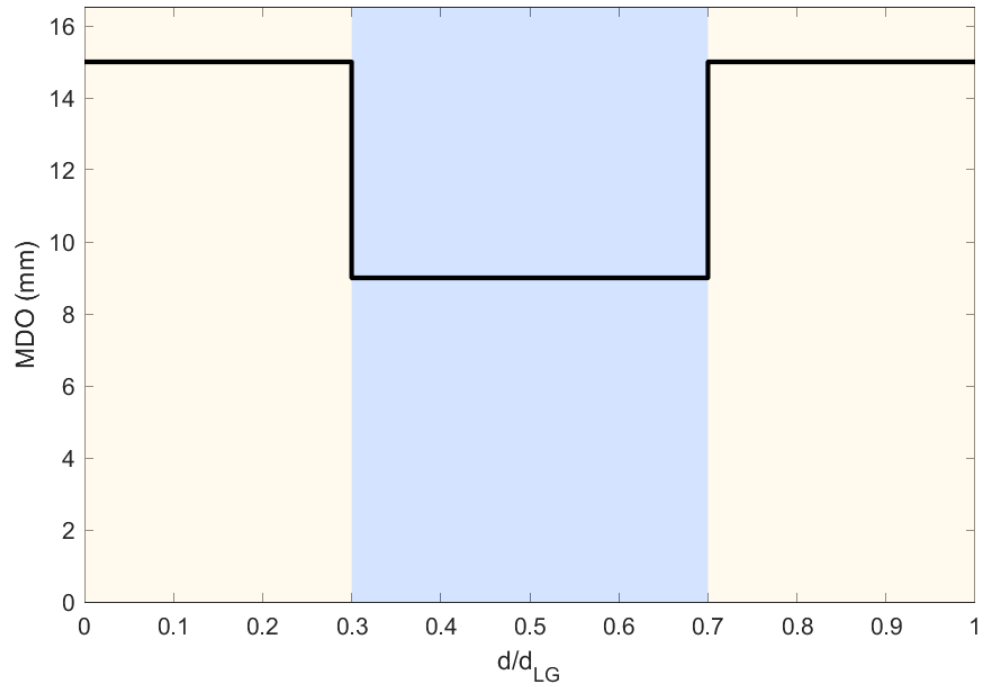

Figure 37: Example MDO 3x cross beam and 10 mm beam separation

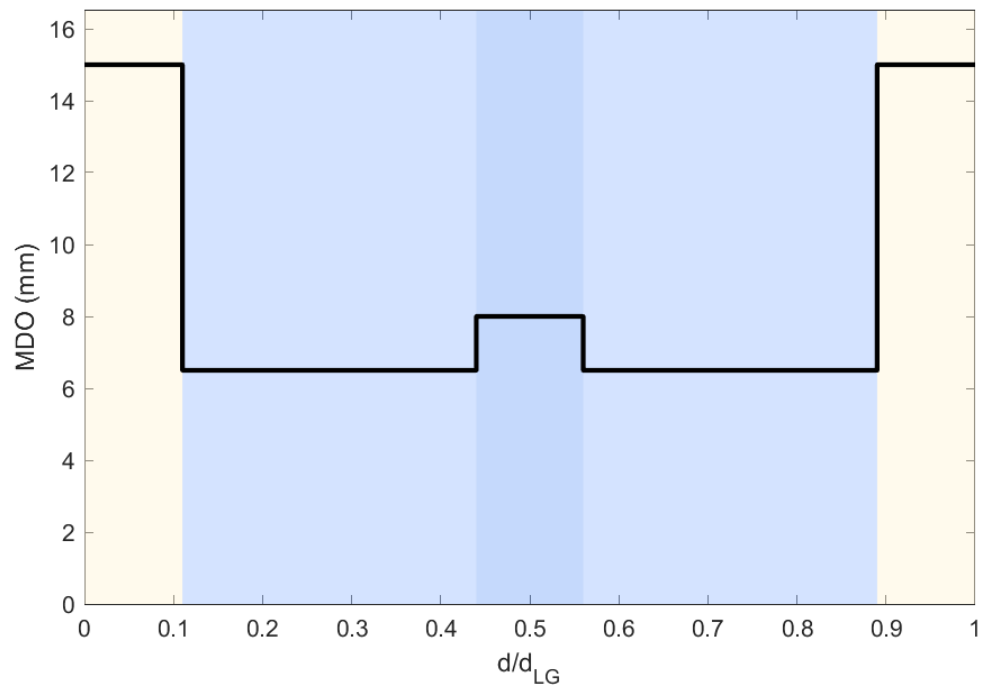

Figure 38: Example MDO 9x cross beam and 10 mm beam separation

11.1.2 Minimum object length (MOL)

Description, [chapter 3.2.4](#).

Minimum object length of static object: MOL = 3 mm

Minimum object length of moving object:

MOL = object speed (mm/ms) x minimum dwell time (ms) + 3 mm

The formula for calculating the minimum dwell time can be found in [chapter](#) under Characteristics.

11.1.3 Minimum object width (MOW)

Description, see "Beam separation, minimum object size, minimum object width and minimum object length", page 11.

Beam crossing allows flat (infinitely thin) objects to be detected if they have a certain minimum object width (MOW = minimum object width). The detection depends on the object position and on the set cross-beam option. The following graphic serves for a better understanding:

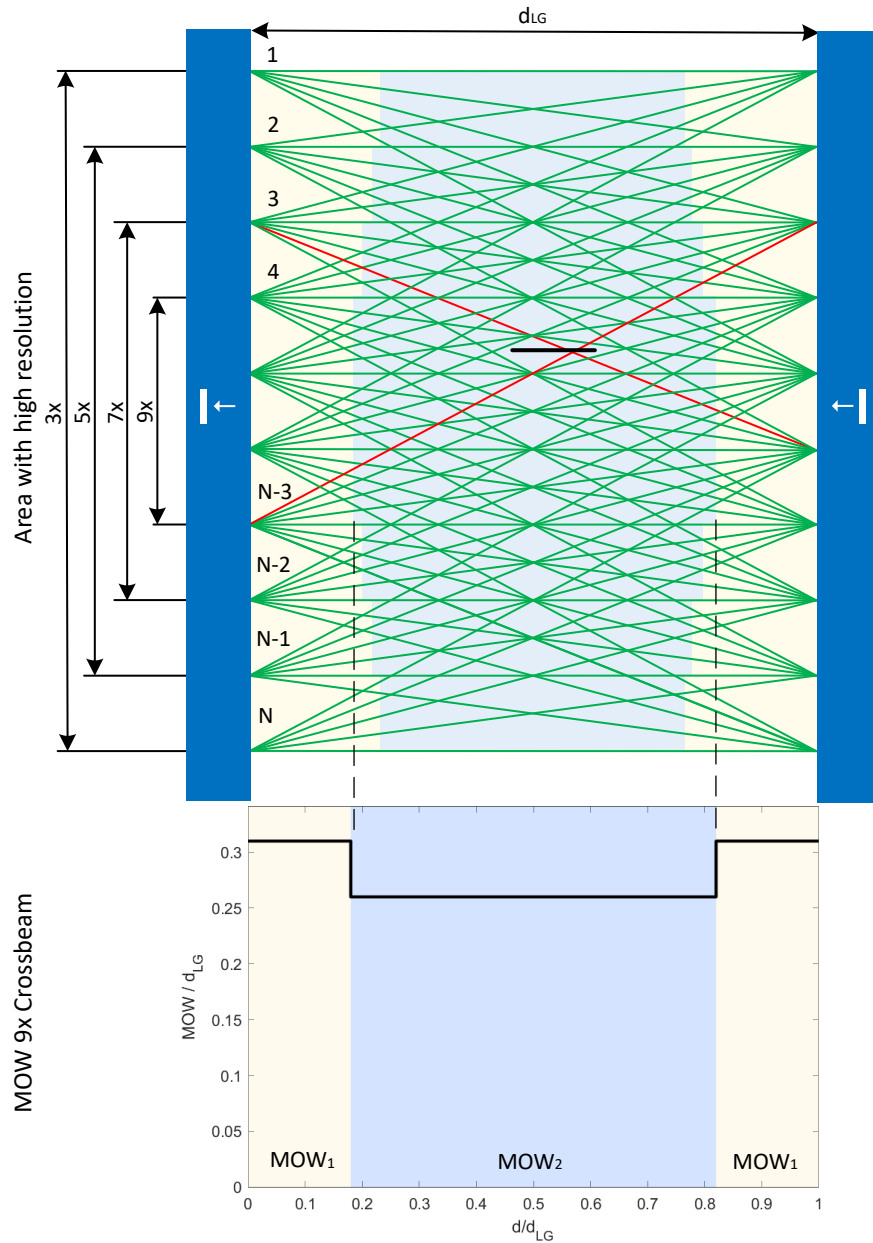

Figure 39: MOW: Example of a light grid with 10 mm beam separation and the set 9x cross-beam option

For the 9x cross-beam option of a device with 10 mm beam separation, the minimum object width MOW is 26% of the sensing range in the MOW2 range. If the sensing range is, for example, 1,000 mm, the infinitely thin object must be at least 260 mm wide in order to be reliably detected in the MOW2 range. The table below contains the MOW data depending on the set cross-beam option and the beam separation of each range.

Table 30: MWO depending on the beam separation, the cross-beam setting as well as the position of the object

Beam separation	Parallel operation	3x	5x	7x	9x
10 mm	MOW1 = 1.00 d _{LG}	MOW1 = 1.00 d _{LG}	MOW1 = 0.62 d _{LG} MOW2 = 0.56 d _{LG}	MOW1 = 0.41 d _{LG} MOW2 = 0.39 d _{LG}	MOW1 = 0.31 d _{LG} MOW2 = 0.26 d _{LG}
25 mm	MOW1 = 1.00 d _{LG}	MOW1 = 1.00 d _{LG}	MOW1 = 0.55 d _{LG} MOW2 = 0.43 d _{LG}	MOW1 = 0.37 d _{LG} MOW2 = 0.31 d _{LG}	MOW1 = 0.28 d _{LG} MOW2 = 0.21 d _{LG}
50 mm	MOW1 = 1.00 d _{LG}	MOW1 = 1.00 d _{LG}	MOW1 = 0.53 d _{LG} MOW2 = 0.38 d _{LG}	MOW1 = 0.35 d _{LG} MOW2 = 0.28 d _{LG}	MOW1 = 0.26 d _{LG} MOW2 = 0.19 d _{LG}
MOW2 range			0.35 - 0.65 d _{LG}	0.22 - 0.78 d _{LG}	0.18 - 0.82 d _{LG}

11.2 Dimensional drawings

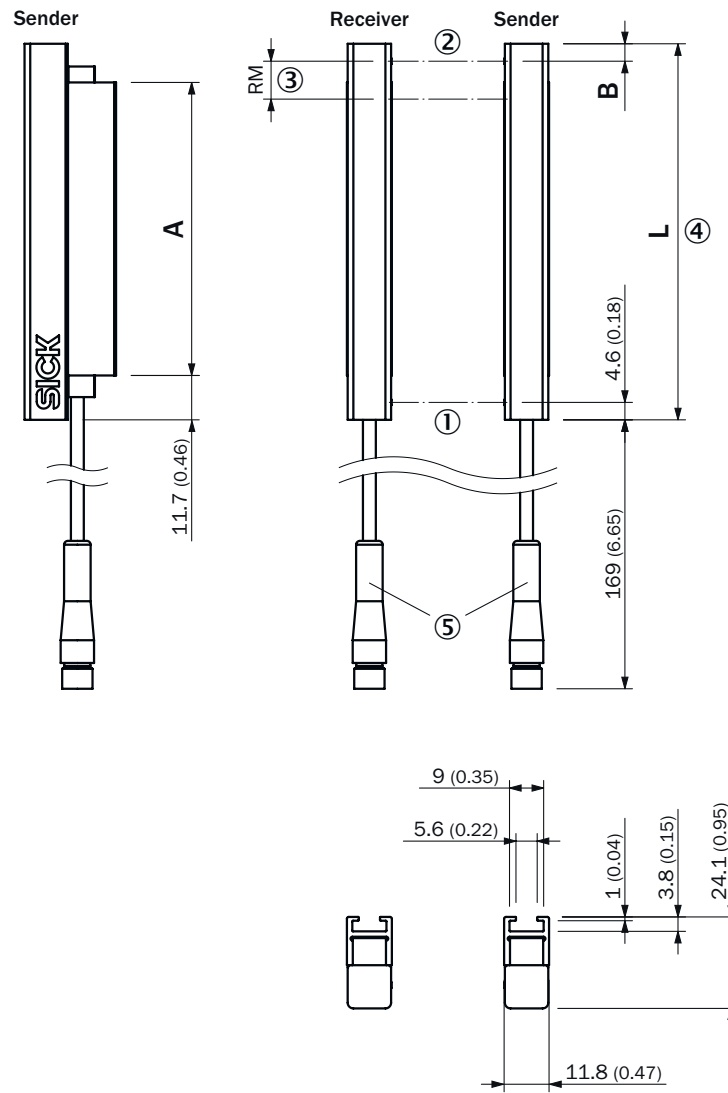

Figure 40: SLG-2 Flat dimensional drawing

- ① First light beam
- ② Last light beam
- ③ Beam separation d_c
- ④ Detection height
- ⑤ Cable with male connector

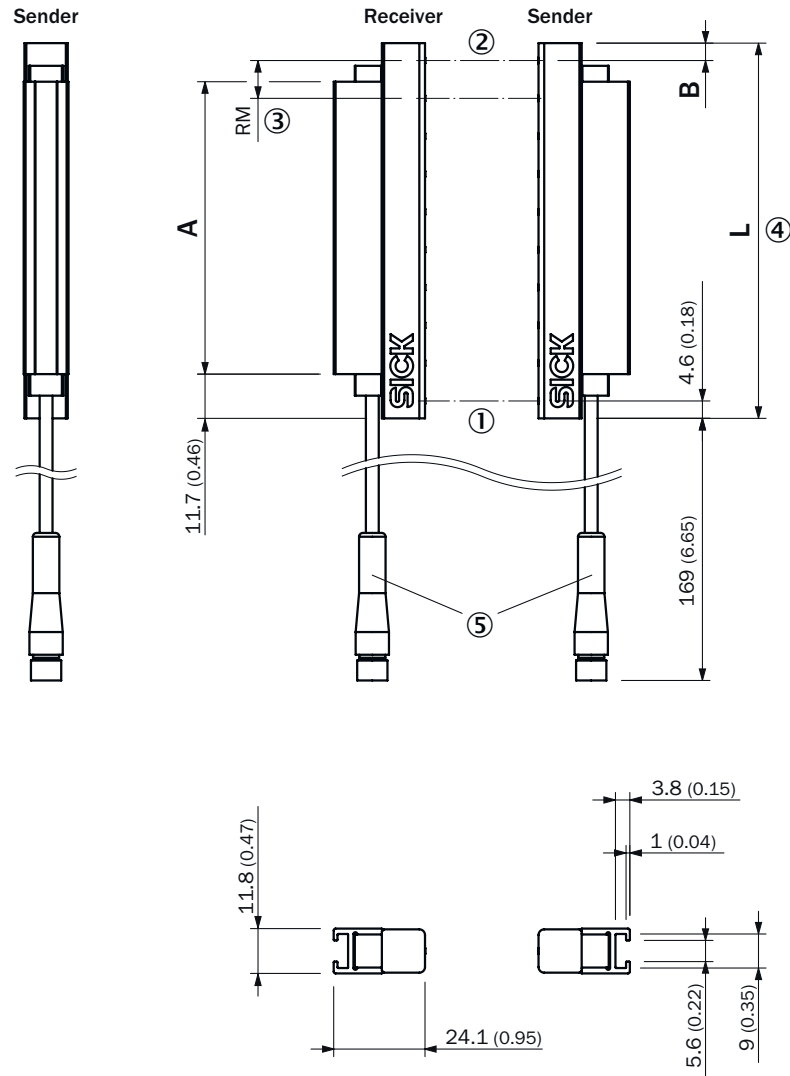

Figure 41: SLG-2 Slim dimensional drawing

- ① First light beam
- ② Last light beam
- ③ Beam separation d_c
- ④ Detection height
- ⑤ Cable with male connector

12 Annex

Australia

Phone +61 (3) 9457 0600
1800 33 48 02 – tollfree
E-Mail sales@sick.com.au

Austria

Phone +43 (0) 2236 62288-0
E-Mail office@sick.at

Belgium/Luxembourg

Phone +32 (0) 2 466 55 66
E-Mail info@sick.be

Brazil

Phone +55 11 3215-4900
E-Mail comercial@sick.com.br

Canada

Phone +1 905.771.1444
E-Mail cs.canada@sick.com

Czech Republic

Phone +420 234 719 500
E-Mail sick@sick.cz

Chile

Phone +56 (2) 2274 7430
E-Mail chile@sick.com

China

Phone +86 20 2882 3600
E-Mail info.china@sick.net.cn

Denmark

Phone +45 45 82 64 00
E-Mail sick@sick.dk

Finland

Phone +358-9-25 15 800
E-Mail sick@sick.fi

France

Phone +33 1 64 62 35 00
E-Mail info@sick.fr

Germany

Phone +49 (0) 2 11 53 010
E-Mail info@sick.de

Greece

Phone +30 210 6825100
E-Mail office@sick.com.gr

Hong Kong

Phone +852 2153 6300
E-Mail ghk@sick.com.hk

Hungary

Phone +36 1 371 2680
E-Mail ertekezes@sick.hu

India

Phone +91-22-6119 8900
E-Mail info@sick-india.com

Israel

Phone +972 97110 11
E-Mail info@sick-sensors.com

Italy

Phone +39 02 27 43 41
E-Mail info@sick.it

Japan

Phone +81 3 5309 2112
E-Mail support@sick.jp

Malaysia

Phone +603-8080 7425
E-Mail enquiry.my@sick.com

Mexico

Phone +52 (472) 748 9451
E-Mail mexico@sick.com

Netherlands

Phone +31 (0) 30 229 25 44
E-Mail info@sick.nl

New Zealand

Phone +64 9 415 0459
0800 222 278 – tollfree
E-Mail sales@sick.co.nz

Norway

Phone +47 67 81 50 00
E-Mail sick@sick.no

Poland

Phone +48 22 539 41 00
E-Mail info@sick.pl

Romania

Phone +40 356-17 11 20
E-Mail office@sick.ro

Russia

Phone +7 495 283 09 90
E-Mail info@sick.ru

Singapore

Phone +65 6744 3732
E-Mail sales.gsg@sick.com

Slovakia

Phone +421 482 901 201
E-Mail mail@sick-sk.sk

Slovenia

Phone +386 591 78849
E-Mail office@sick.si

South Africa

Phone +27 10 060 0550
E-Mail info@sickautomation.co.za

South Korea

Phone +82 2 786 6321/4
E-Mail infokorea@sick.com

Spain

Phone +34 93 480 31 00
E-Mail info@sick.es

Sweden

Phone +46 10 110 10 00
E-Mail info@sick.se

Switzerland

Phone +41 41 619 29 39
E-Mail contact@sick.ch

Taiwan

Phone +886-2-2375-6288
E-Mail sales@sick.com.tw

Thailand

Phone +66 2 645 0009
E-Mail marcom.th@sick.com

Turkey

Phone +90 (216) 528 50 00
E-Mail info@sick.com.tr

United Arab Emirates

Phone +971 (0) 4 88 65 878
E-Mail contact@sick.ae

United Kingdom

Phone +44 (0)17278 31121
E-Mail info@sick.co.uk

USA

Phone +1 800.325.7425
E-Mail info@sick.com

Vietnam

Phone +65 6744 3732
E-Mail sales.gsg@sick.com

Detailed addresses and further locations at www.sick.com

