

# Type ME24 I/O-Module

MAN 1000297454 EN Version: E Status: RL (released | freigegeben) printed: 27.04.2026

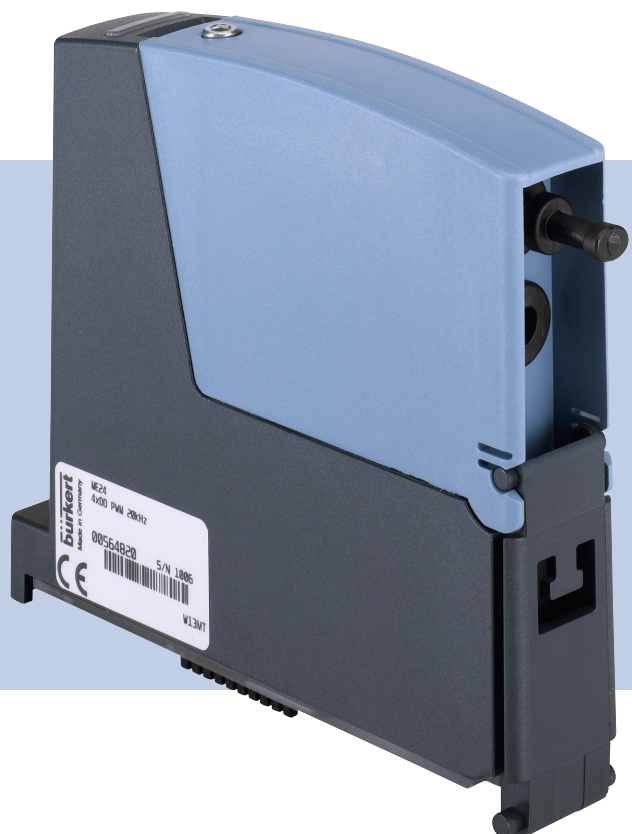

## Operating Instructions

We reserve the right to make technical changes without notice.  
Technische Änderungen vorbehalten.  
Sous réserve de modifications techniques.

© Bürkert Werke GmbH & Co. KG, 2015 -2017

Operating Instructions 1710/02\_EU-EN\_00810473 / Original DE

## I/O module

### CONTENT

<b>1</b>	<b>THE OPERATING INSTRUCTIONS</b> .....	<b>6</b>
1.1	Symbols .....	6
1.2	Definition of the term “product” .....	6
<b>2</b>	<b>AUTHORIZED USE</b> .....	<b>7</b>
<b>3</b>	<b>BASIC SAFETY INSTRUCTIONS</b> .....	<b>8</b>
<b>4</b>	<b>GENERAL INFORMATION</b> .....	<b>9</b>
4.1	Contact address .....	9
4.2	Warranty .....	9
4.3	Information on the Internet.....	9
<b>5</b>	<b>DESCRIPTION OF THE DEVICE</b> .....	<b>10</b>
5.1	Possible combinations.....	10
<b>6</b>	<b>TECHNICAL DATA</b> .....	<b>11</b>
6.1	Conformity .....	11
6.2	Standards.....	11
6.3	Operating conditions .....	11
6.4	Mechanical data.....	12
6.5	Electrical data .....	13
6.5.1	Electrical properties of the inputs and outputs .....	13
<b>7</b>	<b>INSTALLATION</b> .....	<b>15</b>
7.1	Safety instructions .....	15
7.2	Mount Type ME24 on backplane Type BEF1 .....	15
7.3	Connect external sensors and actuators.....	16
7.3.1	Plug configuration and wiring.....	17
<b>8</b>	<b>START-UP</b> .....	<b>23</b>
8.1	Safety instructions .....	23
8.2	Configuration of Type ME24.....	23

<b>9</b>	<b>CONFIGURATION USING THE DISPLAY .....</b>	<b>24</b>
<b>9.1</b>	<b>Brief description of the user interface .....</b>	<b>24</b>
9.1.1	Description of buttons.....	25
<b>9.2</b>	<b>Operating structure .....</b>	<b>26</b>
<b>9.3</b>	<b>User level (access rights) .....</b>	<b>27</b>
9.3.1	Changing the user level (access rights) .....	27
9.3.2	Logging off the user level .....	28
9.3.3	Changing password (PIN).....	28
<b>9.4</b>	<b>Switching to the Parameter, Maintenance or Diagnostics detailed view .....</b>	<b>29</b>
<b>9.5</b>	<b>Setting Bürkert system bus (bÜS).....</b>	<b>30</b>
9.5.1	Detailed views in the bÜS function.....	31
<b>9.6</b>	<b>Setting input module .....</b>	<b>32</b>
9.6.1	Setting analog input.....	32
9.6.2	Calibrating analog input.....	35
9.6.3	Reset analog input to factory settings.....	37
9.6.4	Setting digital input.....	37
9.6.5	Reset totalizer, only when Flow rate operating mode active .....	40
9.6.6	Calibrate digital input, for Flow rate operating mode only .....	41
9.6.7	Resetting digital input to factory settings .....	42
9.6.8	Simulation of a process value on the input module.....	43
<b>9.7</b>	<b>Setting output module .....</b>	<b>44</b>
9.7.1	Setting analog output.....	44
9.7.2	Calibrating analog output .....	47
9.7.3	Resetting analog output to factory settings .....	48
9.7.4	Setting digital output .....	48
9.7.5	Manually actuating output module.....	62
<b>10</b>	<b>DISPLAY ELEMENTS .....</b>	<b>63</b>
10.7.1	Display of device status.....	64
<b>11</b>	<b>MAINTENANCE.....</b>	<b>65</b>
<b>11.1</b>	<b>Safety instructions .....</b>	<b>65</b>
<b>11.2</b>	<b>Replacing devices.....</b>	<b>65</b>
<b>11.3</b>	<b>Replacing the memory card .....</b>	<b>67</b>
<b>11.4</b>	<b>Troubleshooting.....</b>	<b>69</b>

12	ACCESSORIES .....	70
13	PACKAGING AND TRANSPORT .....	71
14	STORAGE.....	71
15	DISPOSAL .....	71

# 1 THE OPERATING INSTRUCTIONS

The operating instructions describe the entire life cycle of the device. Keep these instructions in a location which is easily accessible to every user and make these instructions available to every new owner of the device.

## Important Safety Information.

Read the operating instructions carefully and thoroughly. Study in particular the chapters entitled "[2 Authorized use](#)" and "[3 Basic safety instructions](#)".

- ▶ The operating instructions must be read and understood.

## 1.1 Symbols

### **DANGER!**

**Warns of an immediate danger.**

- ▶ Failure to observe the warning will result in a fatal or serious injury.

### **WARNING!**

**Warns of a potentially dangerous situation.**

- ▶ Failure to observe the warning may result in serious injuries or death.

### **CAUTION!**

**Warns of a possible danger.**

- ▶ Failure to observe this warning may result in a moderate or minor injury.

### **NOTE!**

**Warns of damage to property.**

- Failure to observe the warning may result in damage to the device or the equipment.

 Indicates important additional information, tips and recommendations.

 Refers to information in these operating instructions or in other documentation.

▶ Designates instructions for risk prevention.

→ Designates a procedure which you must carry out.

✔ Indicates a result.

## 1.2 Definition of the term “product”

In these instructions, the term „product“ always refers to the I/O module, Type ME24.

## 2 AUTHORIZED USE

**Non-authorized use of the Type ME24 may be dangerous to people, nearby equipment, and the environment.**

The I/O module Type ME24 collects, converts and compares physical measurement data from external sensors or receives switching commands from bus participants via the bus interface. This measurement data or these switching commands are relayed to external actuators or to bus participants via the bus interface.

- ▶ Use according to the authorized data, operating conditions and conditions of use specified in the contract documents and operating instructions.

### **Observe the following when using the product**

- ▶ Use the device only in conjunction with third-party devices and components recommended and authorized by Bürkert.
- ▶ Use only when in perfect condition and always ensure proper storage, transportation, installation and operation.
- ▶ Use only as intended.

### 3 BASIC SAFETY INSTRUCTIONS

These safety instructions do not make allowance for any

- contingencies and events which may arise during the assembly, operation, and maintenance.
- local safety regulations – the operator is responsible for observing these regulations, also in relation to the installation personnel.



#### **General hazardous situations.**

To prevent injuries:

- ▶ Do not make any internal or external changes on the product and do not subject it to mechanical stress.
- ▶ Secure the system from unintentional actuation.
- ▶ Only trained technicians may perform installation and maintenance work.
- ▶ After an interruption in the power supply, ensure that the process is restarted in a controlled manner.
- ▶ Observe the general rules of technology.

#### **NOTE!**

##### **Electrostatic sensitive components or modules.**

The product contains electronic components which react sensitively to electrostatic discharge (ESD). Contact with electrostatically charged persons or objects are hazardous to these components. In the worst case scenario, they will be destroyed immediately or will fail after start-up.

- Observe the requirements in accordance with EN 61340-5-1 to minimize or avoid the possibility of damage caused by sudden electrostatic discharge.
- Do not touch electronic components while the supply voltage is switched on.

## **4 GENERAL INFORMATION**

### **4.1 Contact address**

#### **Germany**

Bürkert Fluid Control Systems  
Sales Center  
Christian-Bürkert-Str. 13-17  
D-74653 Ingelfingen  
Tel. + 49 (0) 7940 - 10 91 111  
Fax + 49 (0) 7940 - 10 91 448  
E-mail: info@de.buerkert.com

#### **International**

Contact addresses can be found on the final pages of the printed operating instructions.

And also on the Internet at:

[www.burkert.com](http://www.burkert.com)

### **4.2 Warranty**

The warranty is only valid if the Type ME24 is used as intended in accordance with the specified application conditions.

### **4.3 Information on the Internet**

The operating instructions and data sheets for Type ME24 can be found on the Internet at:

[www.burkert.com](http://www.burkert.com)

## 5 DESCRIPTION OF THE DEVICE

The output module of Type ME24 receives the switching commands of bÜS participants via the bÜS interface, processes them and relays this information to externally connected actuators.

The input module of Type ME24 receives the physical measurement data from external sensors. The input module converts and compares this measurement data and communicates the values via the bÜS interface to bÜS participants.

The HMIU module Type ME25, in conjunction with the display Type ME21, can be used to configure the basic functions. Alternatively, this can also be carried out via the "Bürkert Communicator".

### 5.1 Possible combinations

The I/O module Type ME24 can only be operated within a system in combination with additional modules. For setting up a system comprising several modules, please contact your Bürkert sales office.

Example of a system in minimum combination:

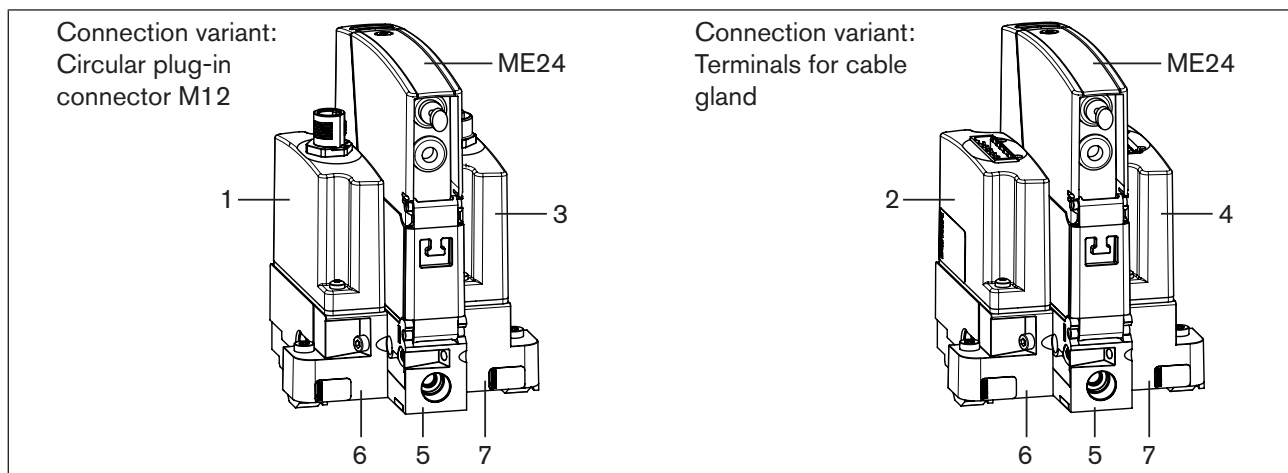

Figure 1: Example of a system: Minimum combination of Type ME24 with additional modules

Module	Designation	Types	Order no.
1	Input module (connection variant: circular plug-in connector M12)	ME29	00564825
2	Input module (connection variant: terminals)	ME29	00564826
3	Output module (connection variant: socket M12)	ME29	00564827
4	Output module (connection variant: terminals)	ME29	00564828
5	Backplane for Type ME24	BEF1	00564841
6	Backplane, left	BEF1	00564844
7	Backplane, right	BEF1	00564846

Table 1: Modules of a possible combination with Type ME24

## 6 TECHNICAL DATA

### 6.1 Conformity

The Type ME24 I/O module conforms to the EU directives according to the EU Declaration of Conformity (if applicable).

### 6.2 Standards

The applied standards, which verify conformity with the EU Directives, can be found on the EU-Type Examination Certificate and / or the EU Declaration of Conformity (if applicable).

### 6.3 Operating conditions



#### **WARNING!**

##### **Risk of injury.**

- ▶ Avoid heat sources which may cause the permissible temperature range to be exceeded.

#### **Permitted temperatures**

Ambient temperature: 0...+50 °C

## 6.4 Mechanical data

Dimensions:

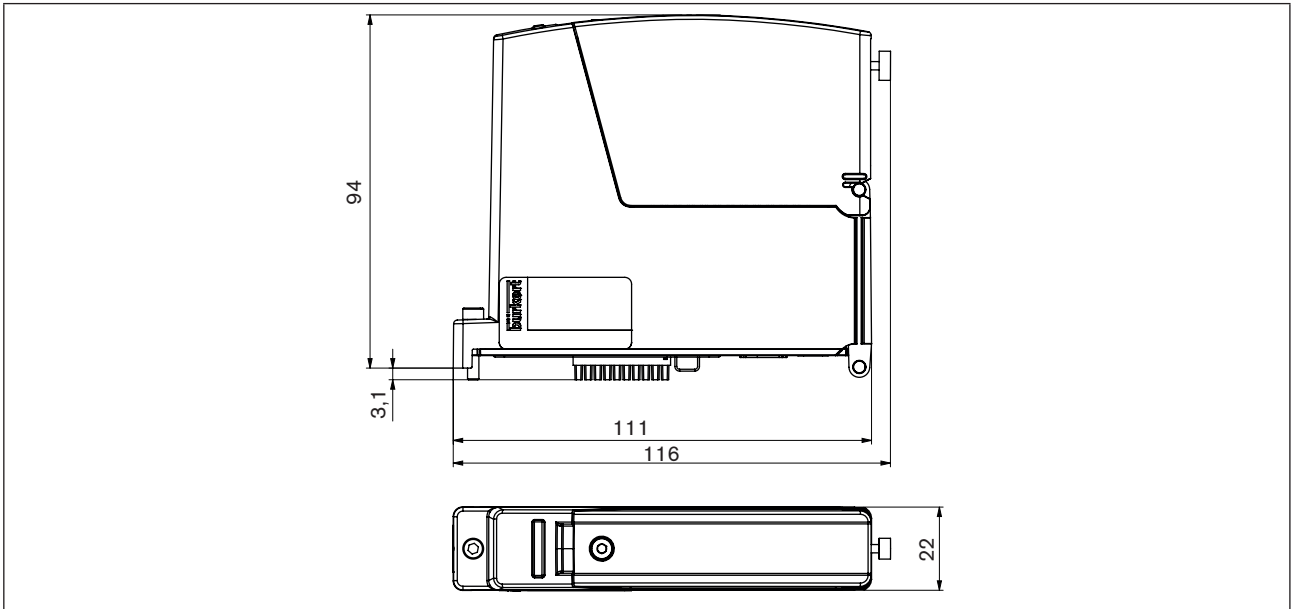

Figure 2: Dimensions

Housing material: Polycarbonate

## 6.5 Electrical data

- Supply voltage: 20...30 V via the backplane BEF1  
 UL devices: Power supply unit restricted to Class 2
- Power consumption: < 3 W  
 If the outputs are supplied via büS, the total current is limited internally to 2 A: max. 48 W
- Degree of protection: IP65 according to EN 60529 / IEC 60529  
 (only if cables, plugs and sockets have been connected correctly)

### 6.5.1 Electrical properties of the inputs and outputs

2AO, 2DO	
Analog output AO	<ul style="list-style-type: none"> <li>▪ Current output: 4...20 mA</li> <li>▪ Galvanic isolation</li> <li>▪ Protection against DC reverse polarity</li> <li>▪ Resolution: 6 µA</li> <li>▪ Maximum loop impedance (at current output 22 mA)                      1350 Ω at 35 V DC                      850 Ω at 24 V DC                      300 Ω at 12 V DC</li> <li>▪ Detection of open loop</li> </ul>
Digital output DO	<ul style="list-style-type: none"> <li>▪ Transistor output</li> <li>▪ Galvanic isolation</li> <li>▪ Max. 2500 Hz</li> <li>▪ Max. 0.7 A per channel                      Max. 1 A per module</li> <li>▪ Operating mode (signals):                      On-Off                      Threshold value                      PWM                      PFM</li> <li>▪ Overload detection</li> </ul>

Table 2: Electrical properties 2AO, 2DO

MAN 1000297454 EN Version: E Status: RL (released | freigegeben) printed: 27.04.2026

4DO PWM 20 kHz	
Digital output DO	<ul style="list-style-type: none"> <li>▪ Transistor output: open drain output</li> <li>▪ Max. 20,000 Hz</li> <li>▪ Max. 0.7 A per channel Max. 1.8 A per module</li> <li>▪ Operating mode (signals): On-Off Threshold value PWM PFM</li> <li>▪ Overload detection</li> </ul>

Table 3: Electrical properties 4DO PWM 20 kHz

2AI, 2DI	
Analog input AI	<ul style="list-style-type: none"> <li>▪ Current input or voltage input: 4 - 20 mA 0 - 20 mA 0 - 10 V 0 - 5 V 0 - 2 V</li> <li>▪ Galvanic isolation</li> <li>▪ Protection against DC reverse polarity</li> <li>▪ Detection of open loop (at voltage input)</li> <li>▪ Input impedance for current measurement: 110 Ω voltage measurement: 120 kΩ</li> </ul>
Digital input DI	<ul style="list-style-type: none"> <li>▪ Voltage input: 0 - 35 V DC</li> <li>▪ Galvanic isolation</li> <li>▪ Protection against DC reverse polarity</li> <li>▪ Frequency: 0.5...2500 Hz</li> <li>▪ Input impedance approx. 3 - 5 kΩ at voltage of 5 - 35 V</li> <li>▪ Switching threshold: <math>V_{ON} = 5 - 35 V</math> <math>V_{OFF} &lt; 2 V DC</math></li> </ul>

Table 4: Electrical properties 2AI, 2DI

MAN 1000297454 EN Version: E Status: RL (released | freigegeben) printed: 27.04.2026

## 7 INSTALLATION

### 7.1 Safety instructions

#### **WARNING!**

**Risk of injury from improper installation.**

- ▶ Installation may be carried out only by trained technicians and with the appropriate tools.
- ▶ Secure system against unintentional activation.
- ▶ Following installation, ensure a controlled restart.

### 7.2 Mount Type ME24 on backplane Type BEF1

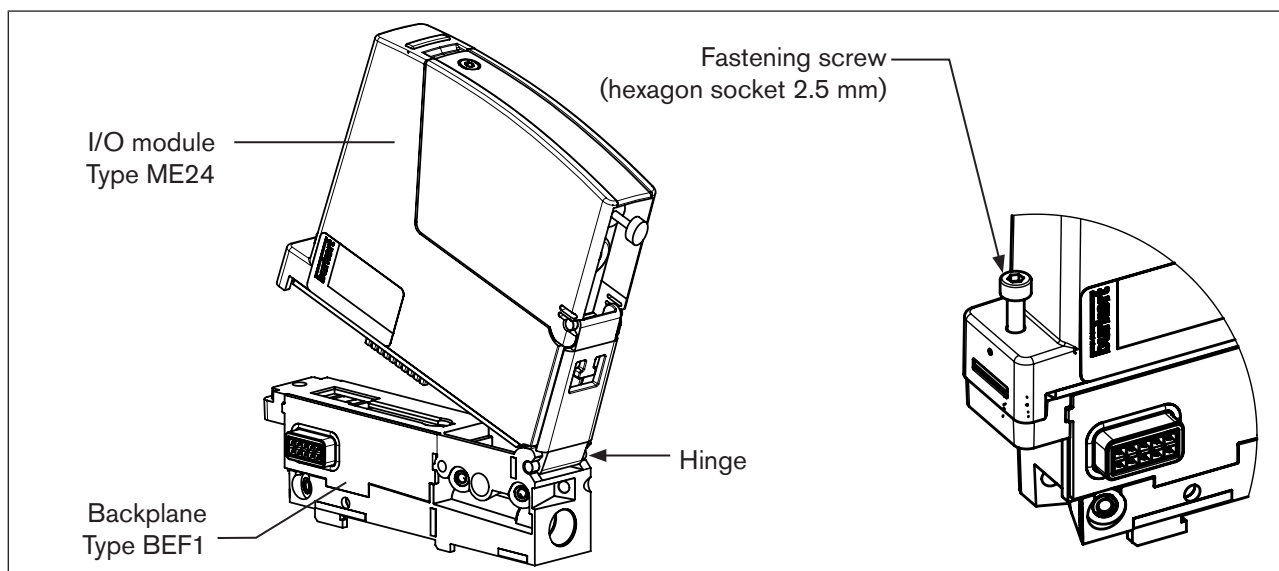

Figure 3: Mount I/O module Type ME24 on backplane Type BEF1

- Insert hinge part of Type ME24 in counter piece of backplane Type BEF1.
- Press Type ME24 fully on the backplane.
- Tighten fastening screw (hexagon socket 2.5 mm). Max. torque 1 Nm.

✓ The Type ME 24 is now connected to the supply voltage on the backplane Type BEF1.

#### **NOTE!**

- ▶ Use power supply with adequate power.

### 7.3 Connect external sensors and actuators

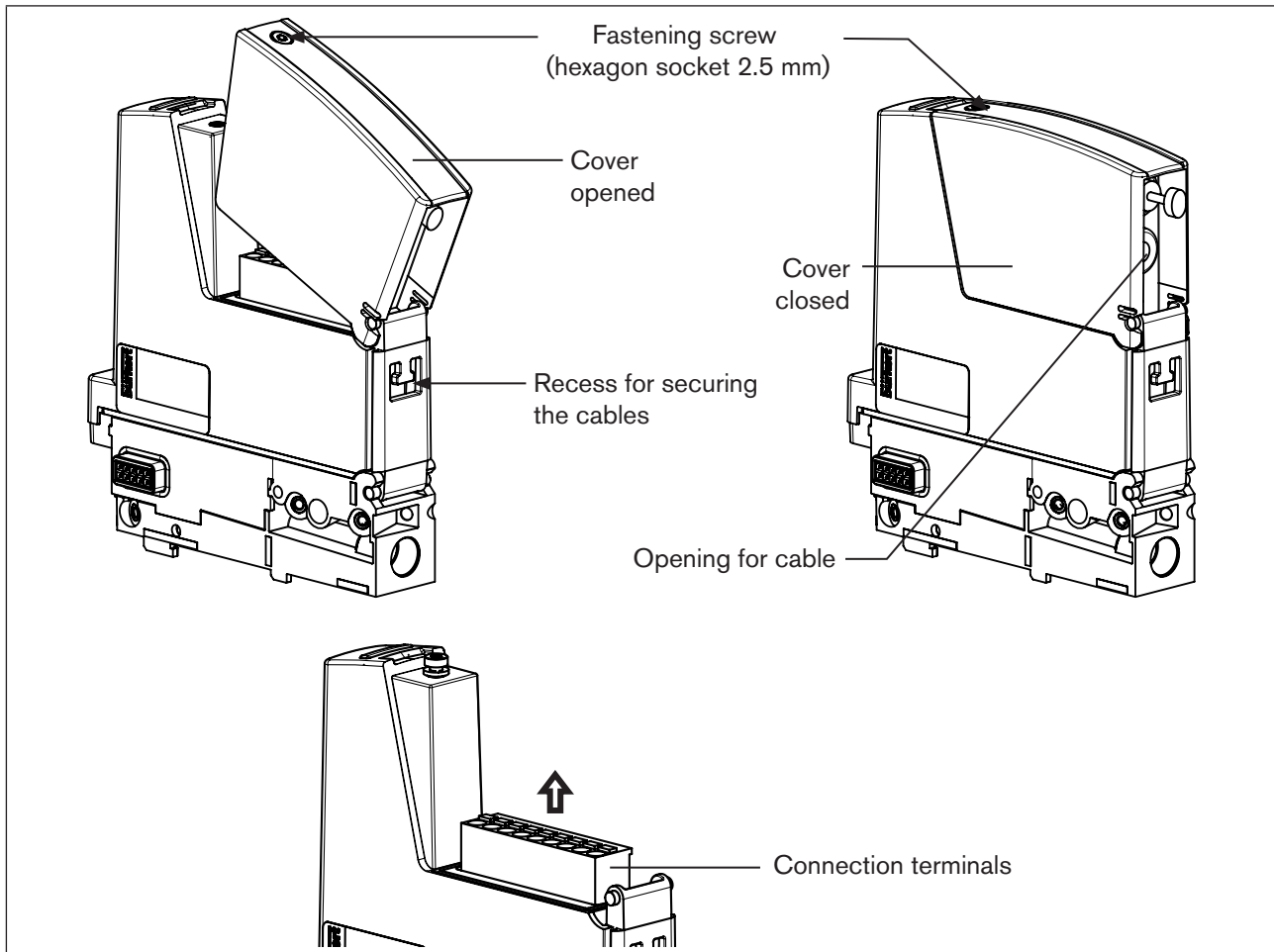

Figure 4: Connect external sensors and actuators

- Unscrew fastening screw at the cover of Type ME24 (hexagon socket 2.5 mm).
- Open and remove cover.
- Pull out connection terminals.
- Insert cables of the external sensors and actuators through the opening on the back of the cover.
- Connect wires of the external sensors and actuators to the connection terminals (plug configuration see chapter [“7.3.1 Plug configuration and wiring”](#)).
- Reconnect connection terminal.
- Close cover and tighten fastening screw. Max. torque 1 Nm.

Fixing the cables for external sensors and actuators (strain relief):  
To relieve the strain, fix the cables to the recess with a cable clip.

### 7.3.1 Plug configuration and wiring

ME24 models 2AO, 2DO, f(x)

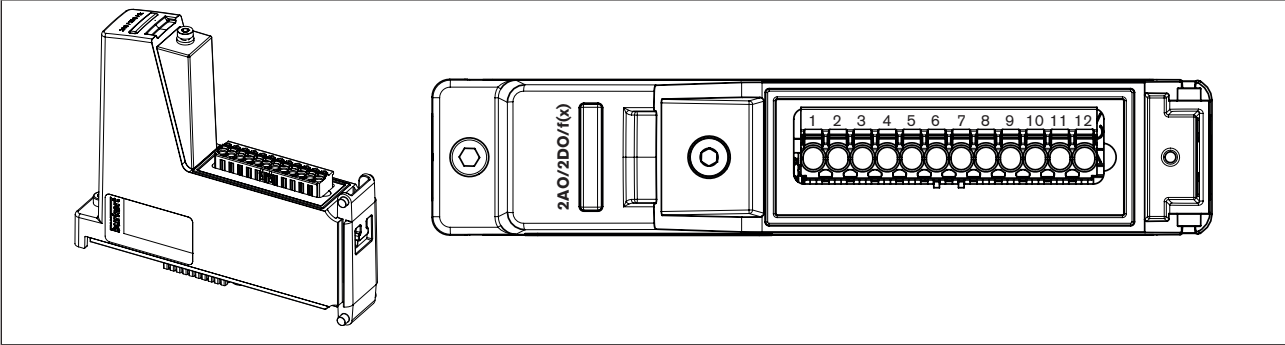

Figure 5: Configuration 2AO, 2DO, f(x)

Pin	2AO, 2DO, f(x)	
	Plug configuration	External circuit
1	+	20 - 30 V / 2 A max. OUTPUT no galvanic isolation
2	-	
3	AO1+	+ (4 - 20 mA) output galvanically isolated
4	AO1-	- (4 - 20 mA) output galvanically isolated
5	FE	Shielding
6	AO2+	+ (4 - 20 mA) output galvanically isolated
7	AO2-	- (4 - 20 mA) output galvanically isolated
8	DO1+	+ NPN galvanically isolated
9	DO1-	- NPN galvanically isolated
10	FE	Shielding
11	DO2+	+ NPN galvanically isolated
12	DO2-	- NPN galvanically isolated

Table 5: Configuration 2AO, 2DO, f(x)

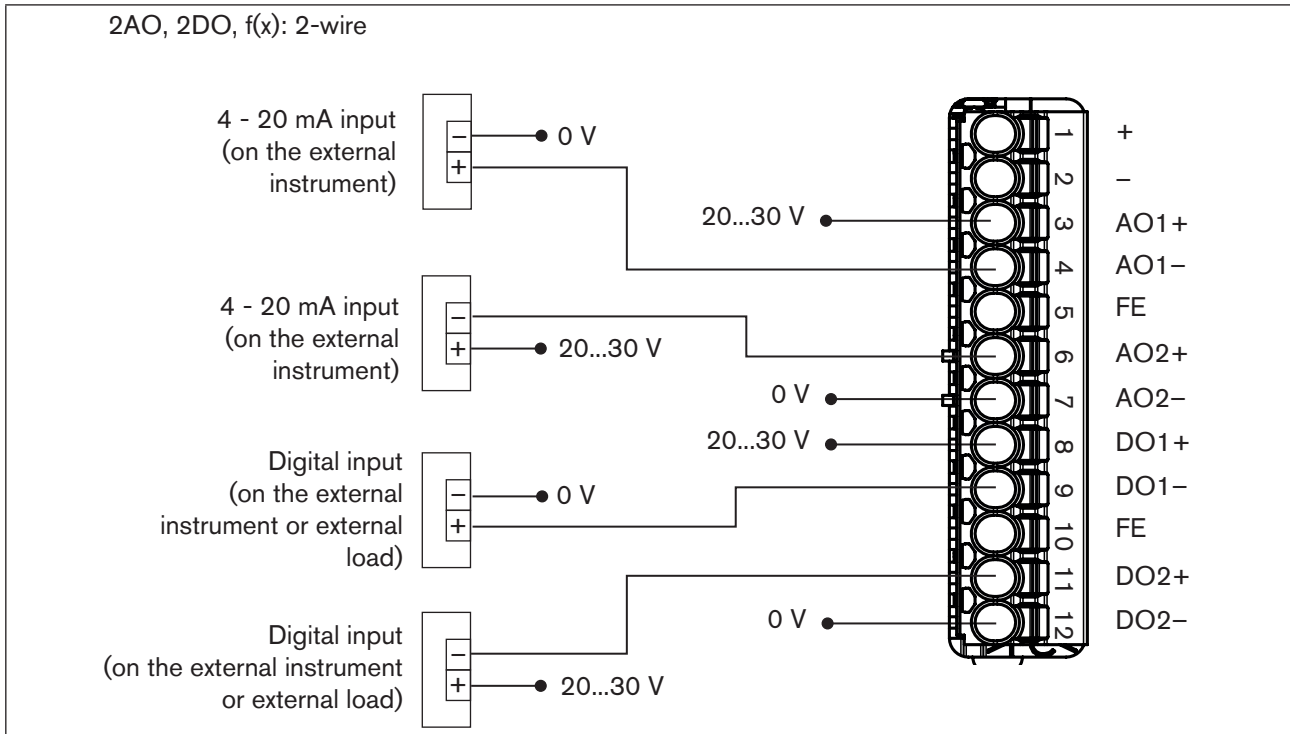

Figure 6: External circuit 2AO, 2DO, f(x), 2-wire

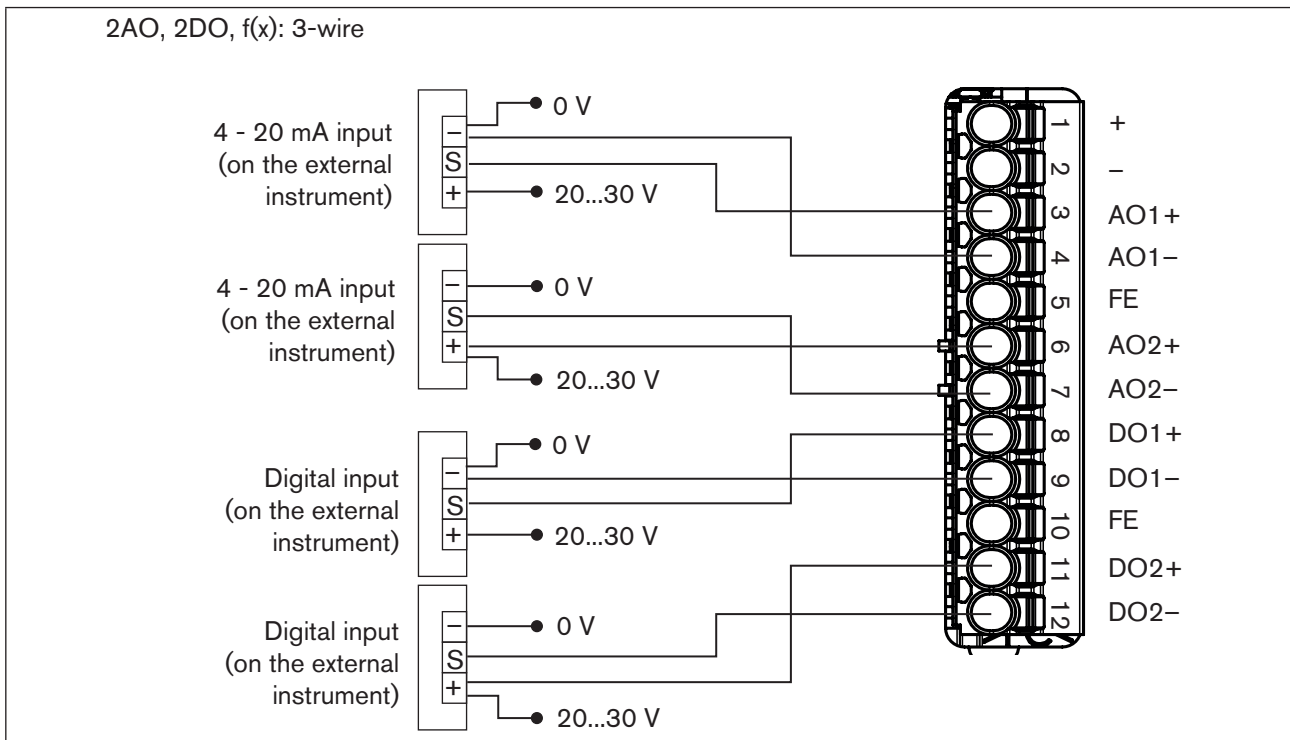

Figure 7: External circuit 2AO, 2DO, f(x), 3-wire

ME24 models 4DO PWM 20 kHz

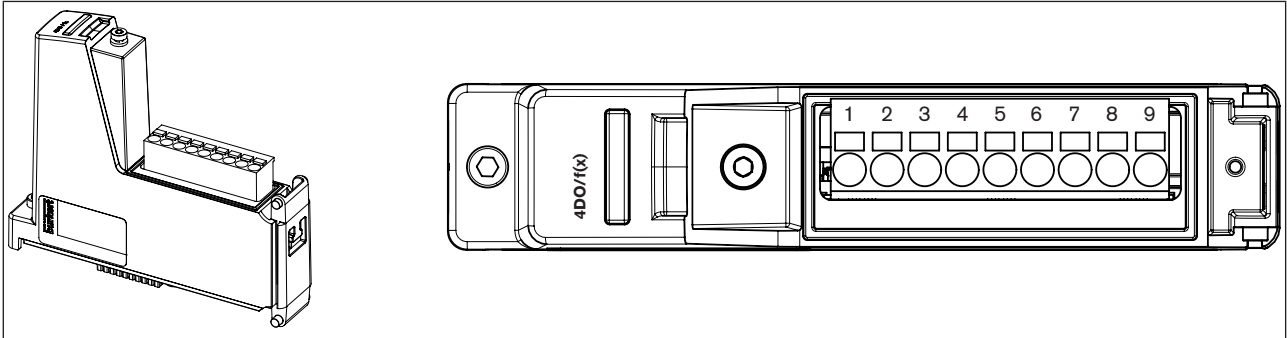

Figure 8: Configuration 4DO PWM 20 kHz

Pin	4DO PWM 20 kHz	
	Plug configuration	External circuit
1	+	20 - 30 V / 2 A max. total current no galvanic isolation
2	DO1-	Open drain
3	+	20 - 30 V / 2 A max. total current no galvanic isolation
4	DO2-	Open drain
5	+	20 - 30 V / 2 A max. total current no galvanic isolation
6	DO3-	Open drain
7	+	20 - 30 V / 2 A max. total current no galvanic isolation
8	DO4-	Open drain
9	FE	Shielding

Table 6: Configuration 4DO PWM 20 kHz

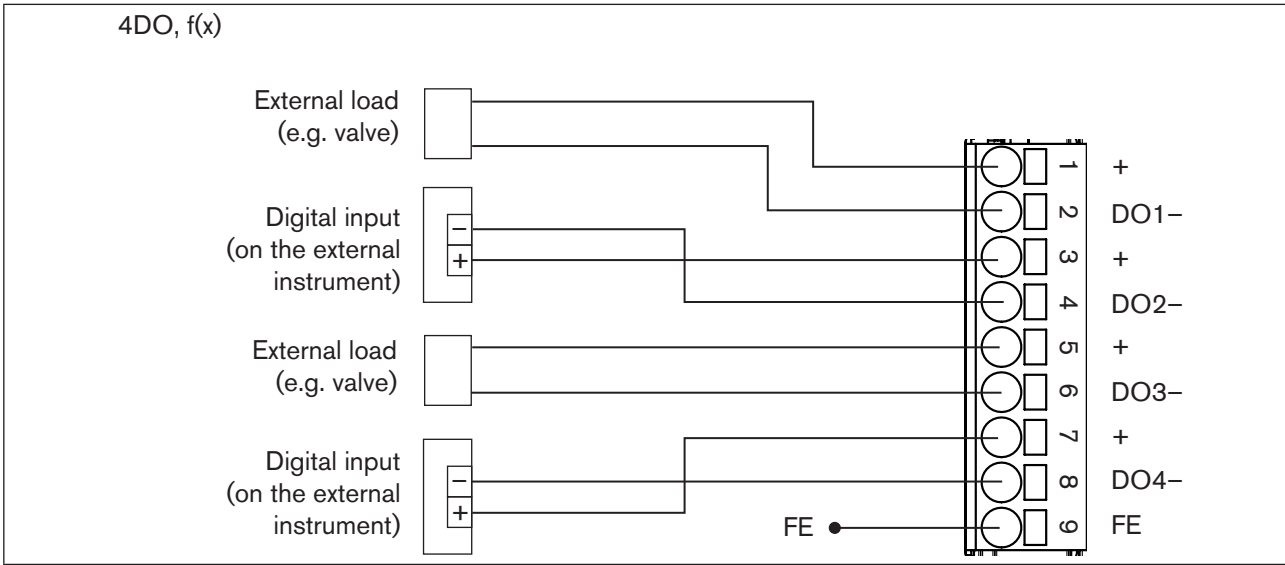

Figure 9: External circuit 4DO PWM 20 kHz

ME24 models 2AI, 2DI

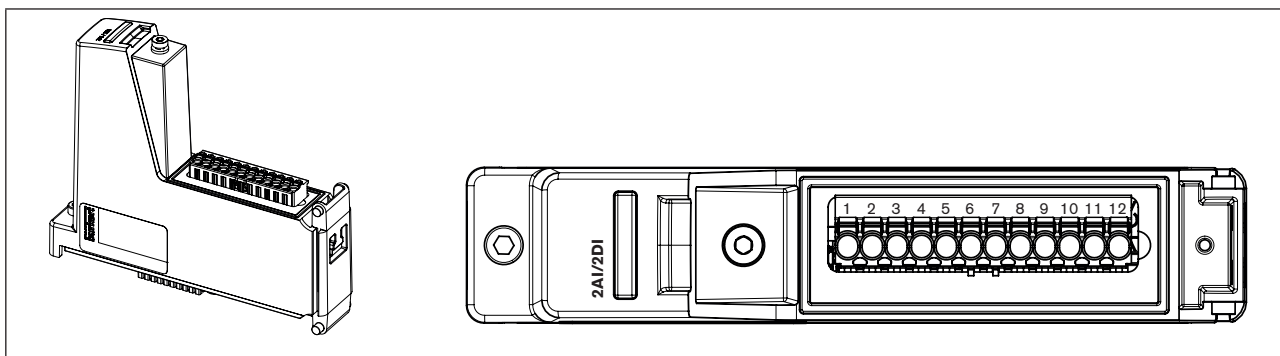

Figure 10: Configuration 2AI, 2DI

Pin	2AI, 2DI	
	Plug configuration	External circuit
1	+	20 - 30 V / 2 A max. OUTPUT no galvanic isolation
2	-	
3	AI1+	+ (0/4 - 20 mA, 0 - 2/5/10 V) Input galvanically isolated
4	AI1-	- (0/4 - 20 mA, 0 - 2/5/10 V) Input galvanically isolated
5	FE	Shielding
6	AI2+	+ (0/4 - 20 mA, 0 - 2/5/10 V) Input galvanically isolated
7	AI2-	- (0/4 - 20 mA, 0 - 2/5/10 V) Input galvanically isolated
8	DI1+	+ (ON: 5 - 35 V, OFF: <2 V) Input galvanically isolated
9	DI1-	- (ON: 5 - 35 V, OFF: <2 V) Input galvanically isolated
10	FE	Shielding
11	DI2+	+ (ON: 5 - 35 V, OFF: <2 V) Input galvanically isolated
12	DI2-	- (ON: 5 - 35 V; OFF: <2 V) Input galvanically isolated

Table 7: Configuration 2AI, 2DI

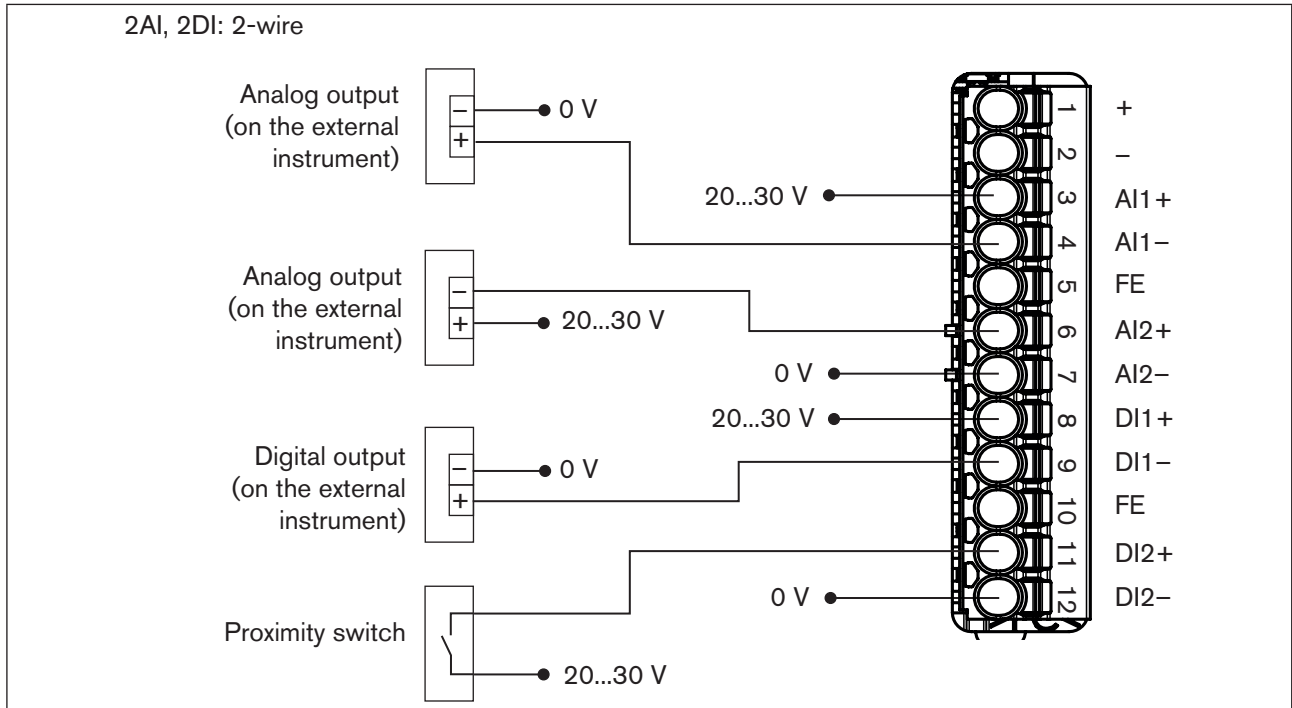

Figure 11: External configuration 2AI, 2DI, 2-wire

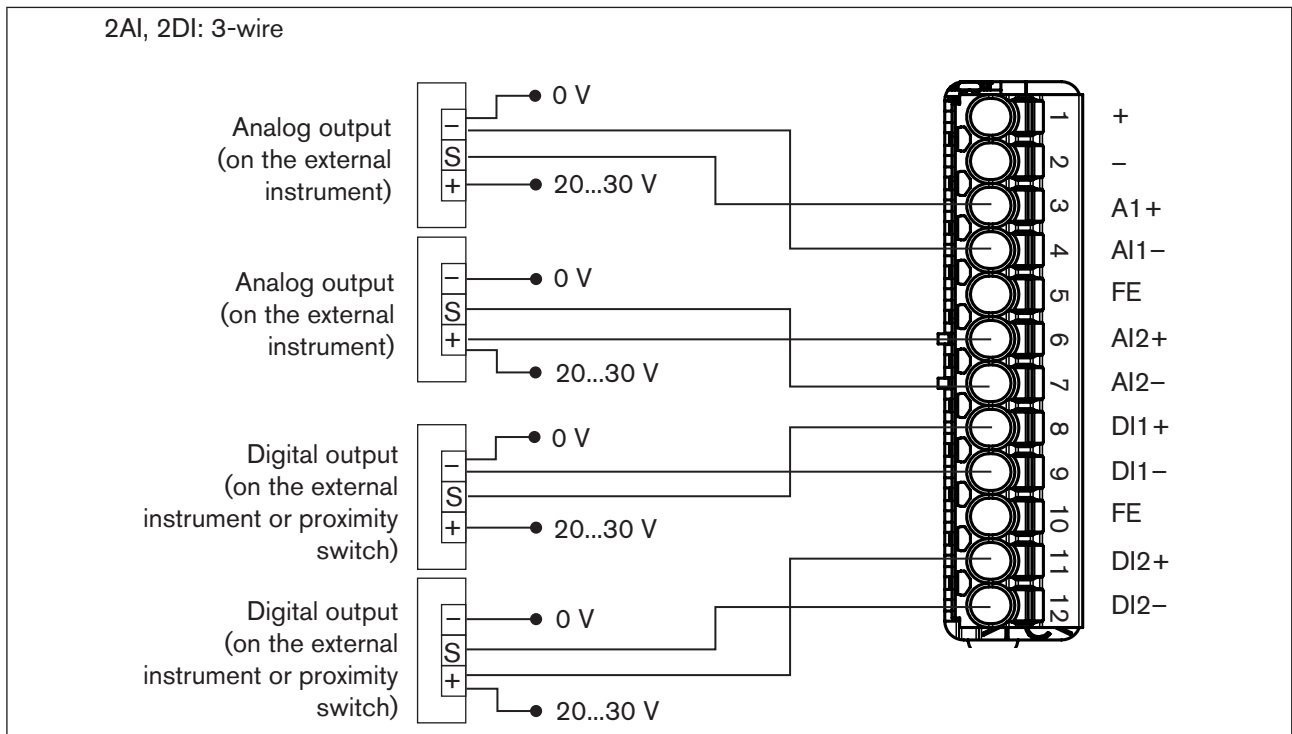

Figure 12: External configuration 2AI, 2DI, 3-wire

## 8 START-UP

### 8.1 Safety instructions



#### WARNING!

##### Risk of injury from improper operation.

Improper operation may result in injuries as well as damage to the device and the area around it.

- ▶ Before start-up, ensure that the operating personnel are familiar with and completely understand the contents of the operating instructions.
- ▶ Observe the safety instructions and intended use.
- ▶ Only adequately trained personnel may start up the equipment/the device.

### 8.2 Configuration of Type ME24

The configuration can be carried out using the display of the connected system or at the PC using the "Bürkert Communicator" software.

The "Bürkert Communicator" and the related general description are available on the Bürkert homepage.



The büS stick, which is available as accessory, is required for configuration using the "Bürkert Communicator". See Chapter ["12 Accessories"](#).



For configuration using the display of the system, refer to the chapter entitled ["9 Configuration using the display"](#).

## 9 CONFIGURATION USING THE DISPLAY

### 9.1 Brief description of the user interface

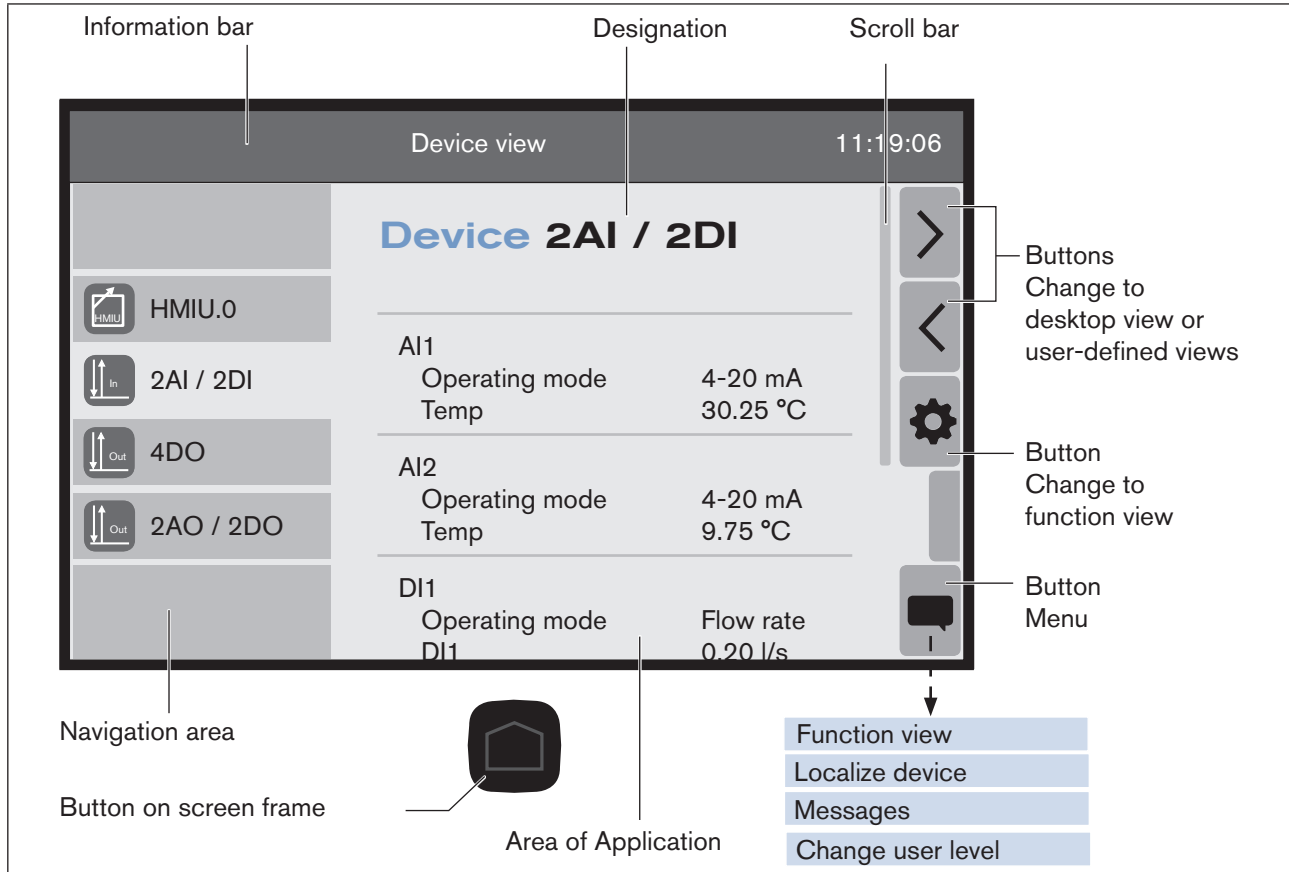



Figure 13: Device view of input module 2AI - 2DI (example)

 The basic operation of the display can be found in the operating instructions "Software for Display" ME21.





Symbol	Description
	HMIU module Type ME25
	Input module
	Output module
	Bürkert system bus (büS)

Table 8: Symbols in the navigation area

Range	Description
Information bar	Designation of the shown view (and of the selected device) or device type and device name.
Buttons	Configuration of the buttons has been adapted to the view, e. g. Toggle views, Menu, ...
Designation and area of application	Designation corresponding to the view. Display of process values, graphs or input options in accordance with the selected view, device or function.
Navigation area	Selection of the connected devices or selection of functions according to the selected view. Is not included in the detailed views.
Scroll bar	Indicates the position on the screen. Is only available if the contents of the navigation area or area application are larger than the use interface.
Button	Exit without saving and change to home screen (Desktop 1).

Table 9: Description of the areas

### 9.1.1 Description of buttons

Button	Command or description	Button	Command or description
	Change view. Available only in desktop views, device view and detailed views		Change to detailed view parameter Available only in function view.
	Change view. Available only in desktop views, device view and detailed views		Back
	Change to device view. Available only in desktop 1 and user-defined views.		Cancel and exit.
	Change to function view. Available only in device view.		Save changes (back up). Input screen, option field remains active. Note: If you exit an input mask using cancel, saved changes are retained.
	Open menu.		Save and exit.

Table 10: Description of buttons

## 9.2 Operating structure

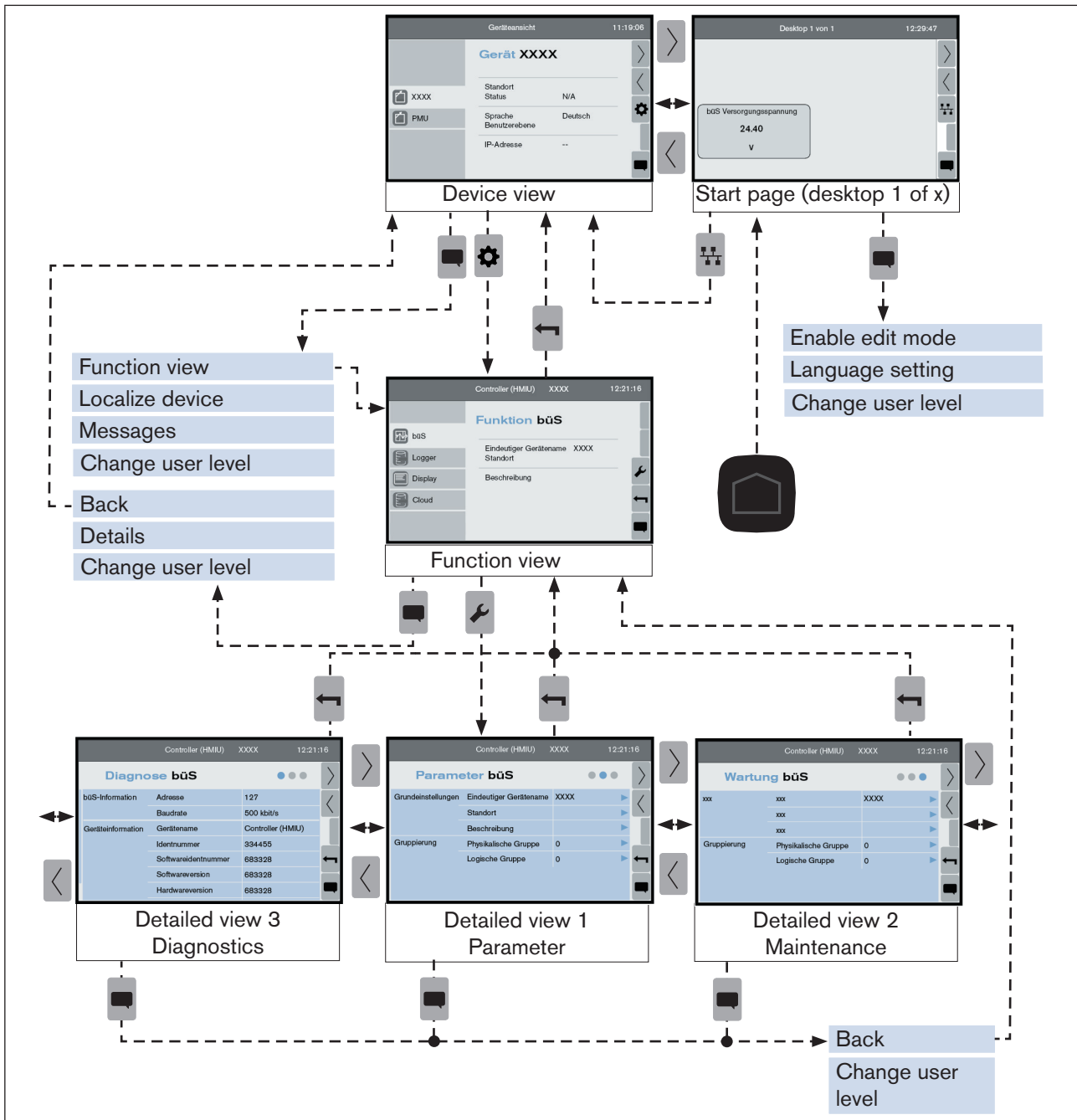

Figure 14: Operating structure

MAN 1000297454 EN Version: E Status: RL (released | freigegeben) printed: 27.04.2026

## 9.3 User level (access rights)

### 9.3.1 Changing the user level (access rights)

The user can change the user level in the views.

The user can select the following user level with appropriate rights:

Symbol	User level	Description
	User	No PIN required <ul style="list-style-type: none"> <li>▪ Can read specified values</li> <li>▪ Restricted rights to change values</li> </ul>
	Advanced user	PIN required (default PIN: 5678) <ul style="list-style-type: none"> <li>▪ Can read specified values</li> <li>▪ Restricted rights to change values</li> </ul>
	Installer	PIN required (default PIN: 1946) <ul style="list-style-type: none"> <li>▪ Can read all values</li> <li>▪ Extended rights to change values</li> </ul>
	Bürkert	PIN required <ul style="list-style-type: none"> <li>▪ For Bürkert Service only</li> </ul>

Table 11: User level

#### Changing the user level:

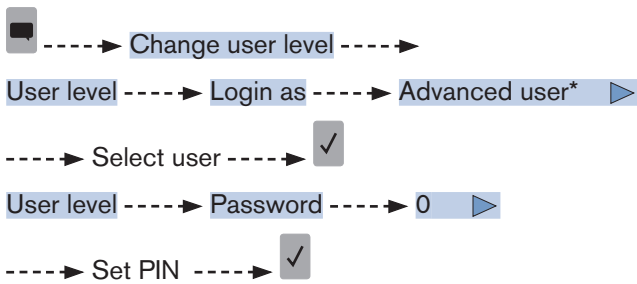

The user level is set and the symbol appears on the information bar.

\* The next higher user level appears here.

The selected user level is active until:

- The user logs off the user level.
- The screen saver becomes active.

### 9.3.2 Logging off the user level

Logging off the user level:

 -----> **Change user level** ----->

**User level** -----> **Logout**  >

 The user level is the standard user.

### 9.3.3 Changing password (PIN)

Changing password:

 -----> **Change user level** ----->

**User level** -----> **Change password**  >

**Change password** -----> **Enter password** -----> **0** >

-----> Set PIN.





**Change password** -----> **Confirm password** -----> **0** >

-----> Set PIN.

 The password is changed.

## 9.4 Switching to the Parameter, Maintenance or Diagnostics detailed view

The user can make settings in the Parameter and Maintenance detailed views only.

Press button or list field	Command or description
<p>→ Change to device view.</p> <p>→ Choose device in the navigation area.</p>	
<p><input checked="" type="checkbox"/> Process data of the device is displayed in the application area.</p>	
 <p>or</p>  <p>Function view</p> <p>xx</p> <p>xx</p> <p>xx</p>	<p>Change to function view.</p>
<p><input checked="" type="checkbox"/> The display shows the function view of the selected device.</p>	
<p>→ Choose function in the navigation area</p>	
<p><input checked="" type="checkbox"/> The data of the selected function is shown in the area of application.</p>	
 <p>or</p> <p>Details</p> <p>xx</p>	<p>Change to detailed view.</p>
<p><input checked="" type="checkbox"/> The display shows the detailed view Parameters of the selected function.</p>	
 	<p>Change to Diagnostics, Parameters or Maintenance detailed views.</p>
<p>→ Make settings.</p>	

## 9.5 Setting Bürkert system bus (bÜS)

Data and settings for the Bürkert system bus for each I/O module.

e. g. designation, identification, versions

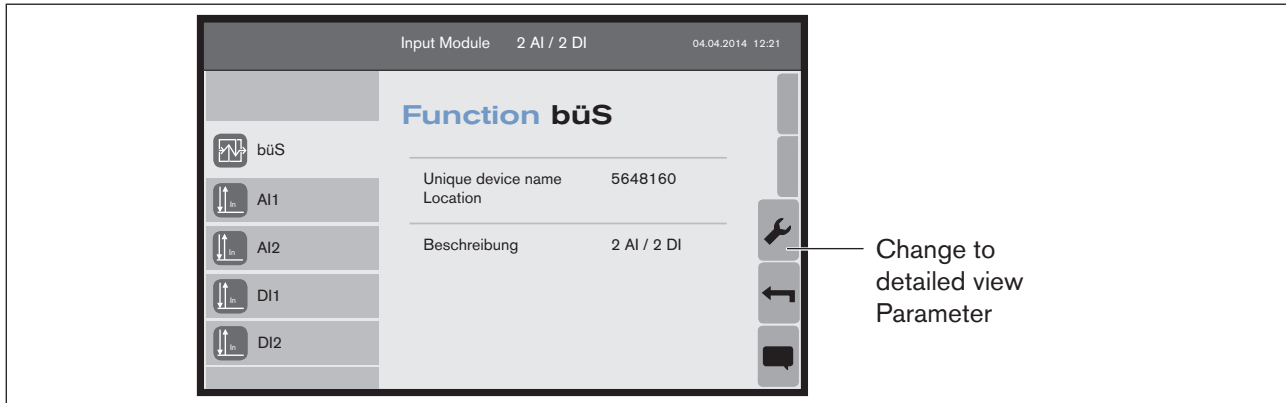

Figure 15: büS function view, input module (example)

### Procedure:

- Switch to device view.
- Select device in the navigation area.
- Switch to function view.
- Select büS in the navigation area.
- ✓ The display shows the büS function view of the selected device.

### 9.5.1 Detailed views in the büS function

	<p><b>Detailed view Parameter büS</b></p> <p>Option for setting user-specific data for device identification.</p> <ul style="list-style-type: none"> <li>▪ Designation and description</li> <li>▪ Location</li> <li>▪ Address</li> </ul> <p>▶ opens an input screen. → Make settings.</p>
	<p><b>Detailed view Diagnostics büS</b></p> <p>Representation of büS information and device information.</p> <ul style="list-style-type: none"> <li>▪ Address and baud rate</li> <li>▪ Device name and device identification</li> <li>▪ Software information and hardware information</li> <li>▪ Device driver information</li> </ul> <p>No changes by user are possible.</p>
	<p><b>Detailed view Maintenance büS</b></p> <p>Device is restarted (software reset).</p>

Table 12: Detailed views büS

MAN 1000297454 EN Version: E Status: RL (released | freigegeben) printed: 27.04.2026

## 9.6 Setting input module

### 9.6.1 Setting analog input

User level: Installer

→ Switch to detailed view Parameters.

→ ① Select input signal (operating mode).

→ ② Change name if required.

→ ③ Select physical size and unit.

→ ④ Assign the lower value of the physical size to the lower value of the input signal.

→ ⑤ Assign the upper value of the physical size to the upper value of the input signal.

→ ⑥ Set response time of the filter.

→ ⑦ Set warning limit values and error limit values.

**Re ①: Select input signal (operating mode).**

Configure -----> Operating mode -----> Not configured\* ▶

Possible selection:

- Not configured
- 4-20 mA
- 0-20 mA
- 0-10 V
- 0-5 V
- 0-2 V

-----> Select input signal ----->

The input signal is set.

\* The value set previously appears here.

**Re ②: Change name.**

Configure -----> Name -----> AI1\* ▶ | -----> Set name ----->

The name is set.

\* The value set previously appears here.

Re ③: Select physical size and unit.

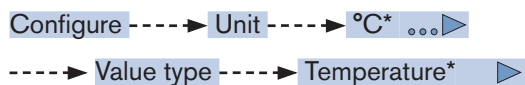

Possible selection:

- No unit
- Concentration g/l, mg/l, µg/l, ppm, ppb
- Conductivity mS/cm, µS/cm
- Current mA, µA, nA, pA
- Flow rate l/h, l/min, l/s, m³/h, m³/min, m³/s, USgal/h, USgal/min, USgal/s, Impgal/h, Impgal/min, Impgal/s
- Frequency mHz, Hz, kHz, MHz
- pH value pH
- Pressure Pa, bar, at, atm, Torr, psi
- Resistivity Ω·cm, KΩ·cm
- Velocity m/s, mm/s
- Temperature K, °C, °F
- Turbidity FNU, NTU
- Voltage V, mV, µV
- Volume ml, l, m³, fl.oz. (Imp), USgal, Impgal
- Units per time 1/s, 1/min, 1/h, 1/d

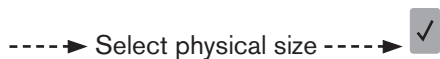

Possible selection:

The units appear according to the selected physical size.

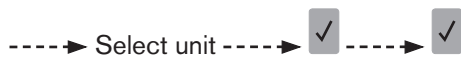

The physical size and the unit are set.

\* The value set previously appears here.

Re ④: Assign the lower value of the physical size to the lower value of the input signal.

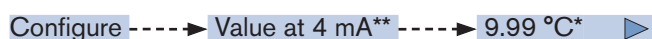

The assignment is set.

\* The value set previously appears here.

\*\* The lower value of the set input signal appears here.

**Re ⑤: Assign the upper value of the physical size to the upper value of the input signal.**

Configure -----> Value at 20 mA\*\* -----> 30 °C\* >

-----> Set value -----> ✓

✓ The assignment is set.

\* The value set previously appears here.

\*\* The upper value of the set input signal appears here.

**Re ⑥: Set filter response time.**

The user uses this function to specify the degree of damping for current fluctuations or voltage fluctuations of the input signal.

Configure -----> Filter response time -----> 3 s\* >

-----> Set value -----> ✓

✓ The filter response time is set.

\* The value set previously appears here.

**Re ⑦: Set warning limit values and error limit values.**

The user uses this function to specify the warning limit values and error limit values for the input signal and/or the physical size.

Example of warning limit values:

Messages triggers -----> Warnings -----> ... >

Warning triggers -----> Activations flag -----> Empty list >

Possible selection:

- Low limit
- High limit
- Low raw limit
- High raw limit
- Open loop

-----> Activate activation flags -----> ✓

-----> Setting the values in the following menu according to the selected activation flags:

Warning triggers -----> Low limit -----> -10 °C\* >

Warning triggers -----> High limit -----> -10 °C\* >

Warning triggers -----> Low raw limit -----> 0 mA\* >

Warning triggers -----> High raw limit -----> 0 mA\* >

-----> ✓

✓ The warning triggers and values are set.

\* The value set previously appears here

## 9.6.2 Calibrating analog input

User level: Installer

→ Switch to Maintenance detailed view.

Possible calibration of the analog inputs:

- Calibration of the analog input with regard to a measured variable
- Calibration of the analog input (current or voltage)
- Calibration of the analog input to factory settings

### Calibration of the analog input with regard to a measured variable

This calibration does not replace the calibration of the connected device.

Calibration -----> 2-point calibration ----->

The input assistant starts.

Input value for point 1 -----> -10 °C\*

-----> Set value ----->

-----> Wait until the measured value stabilizes ----->

Input value for point 2 -----> -10 °C\*

-----> Input value ----->

-----> Wait until the measured value stabilizes ----->

The calculated values are displayed.

-----> Accept or Reject

Accept:

----->

The settings are accepted.

Reject:

----->

The input assistant stops.

\* The value set previously appears here.

**Calibration of the analog input (current or voltage)**

Hardware calibration -----> 2-point calibration ...>

The input assistant starts.

Input value for point 1 -----> 0 mA\* >

-----> Set value -----> ✓

-----> Wait until the measured value stabilizes -----> ✓

Input value for point 2 -----> 0 mA\* >

-----> Set value -----> ✓

-----> Wait until the measured value stabilizes -----> ✓

The calculated values are displayed.

-----> Accept > or reject ✕

Accept:

-----> ✓

✓ The settings are accepted.

Reject:

-----> ✓

✓ The input assistant stops.

\* The value set previously appears here.

**Calibration of the analog input to factory settings**

Hardware calibration -----> Reset to factory calibration ...>

The input assistant starts.

-----> ✓

✓ The settings are accepted.

### 9.6.3 Reset analog input to factory settings

User level: Installer

→ Switch to Maintenance detailed view.

Factory setting for analog inputs: Input signal 0 - 10 V

Reset to factory settings 



 The settings are accepted.

### 9.6.4 Setting digital input

User level: Installer

→ Switch to Parameters detailed view.

→ ① Select operating mode.

→ ② Change name if required.

→ ③ Select unit. Active for flow rate operating mode only.



→ ④ Select totalizer unit. Active for flow rate operating mode only.

→ ⑤ Set response time of the filter. Active for flow rate operating mode only.

→ ⑥ Set K factor. Active for flow rate operating mode only.



→ ⑦ Set warning limit values and error limit values.

**Re ①: Select operating mode.**

Configure  Operating mode  Not configured\* 

Possible selection:

- Not configured
- Binary
- Flow rate

 Select operating mode  

 The operating mode is set.

\* The value set previously appears here.

**Re ②: Change name.**

Configure -----> Name -----> DI1\* >

-----> Set name -----> ✓

✓ The name is set.

\* The value set previously appears here.

**Re ③: Select unit. Active for flow rate operating mode only.**

Configure -----> Unit -----> l/s\* ... >

-----> Unit -----> l/s\* >

Possible selection:

- l/h
- l/min
- l/s
- m<sup>3</sup>/h
- m<sup>3</sup>/min
- m<sup>3</sup>/s
- USgal/h
- USgal/min
- USgal/s
- Impgal/h
- Impgal/min
- Impgal/s

-----> Select unit -----> ✓ -----> ✓

✓ The unit is set.

\* The value set previously appears here.

**Re ④: Select totalizer unit. Active for flow rate operating mode only.**

Configure -----&gt; Totalizer unit -----&gt; 1\* ▶

Possible selection:

- l
- m<sup>3</sup>
- USgal
- Impgal

-----&gt; Select unit -----&gt; ✓

 The unit is set.

*\* The value set previously appears here.*
**Re ⑤: Set filter response time. Active for flow rate operating mode only.**

The user uses this function to specify the degree of damping for measured value fluctuations of the digital input.

Configure -----&gt; Filter response time -----&gt; 3 s\* ▶

-----&gt; Set value -----&gt; ✓

 The filter response time is set.

*\* The value set previously appears here.*
**Re ⑥: Set K factor. Active for flow rate operating mode only.**

Configure -----&gt; K factor -----&gt; 1\* ▶

-----&gt; Set K factor -----&gt; ✓

 The K factor is set.

*\* The value set previously appears here.*

**Re ⑦: Set warning limit values and error limit values.**

The user uses this function to specify the warning limit values and error limit values for the input signal and/or the physical size.

Example of warning limit values:

Messages triggers -----> Warnings -----> ...▶

The input assistant starts.

Warning triggers -----> Activation flag -----> Empty list ▶

Possible selection: Flow rate operating mode

Low limit

High limit

Possible selection: Binary operating mode

Input not activated

Input activated

-----> Activate activation flags ----->

-----> Setting the values in the following menu according to the selected activation flags: Active for flow rate operating mode only.

Warning triggers -----> Low limit -----> 0 l/s\* ▶

Warning triggers -----> High limit -----> 0 l/s\* ▶

----->

The warning triggers and values are set.

\* The value set previously appears here.

**9.6.5 Reset totalizer, only when Flow rate operating mode active**

User level: Installer

→ Switch to Maintenance detailed view.

Reset totalizer ...▶

----->

The totalizer is reset.

### 9.6.6 Calibrate digital input, for Flow rate operating mode only

User level: Installer

→ Switch to Maintenance detailed view.

Possible calibration of the digital inputs:

- Setting K factor
- Calibrating the flow rate volume
- Calibrating the flow rate

#### Calibrating the flow rate volume to determine the K factor.

Calibration -----> Volume teaching

The input assistant starts.

Volume unit -----> ml\*

-----> Select unit ----->

Flow unit -----> l/h\*

-----> Select unit ----->

----->

The measurement starts.

-----> Wait until the measurement has ended ----->

Reference volume -----> 0 ml\*

-----> Set value ----->

The calculated K factor is displayed.

-----> Accept or Reject

Accept:

-----> ----->

The settings are accepted.

Reject:

----->

The input assistant stops.

\* The value set previously appears here.

MAN 1000297454 EN Version: E Status: RL (released | freigegeben) printed: 27.04.2026

**Calibrating the flow rate to determine the K factor.**

Calibration -----> Flow teaching ...>

The input assistant starts.

Flow unit -----> l/h\* >

-----> Select unit -----> ✓

-----> >

The measurement starts.

-----> Wait until the measurement has ended.

Reference flow -----> 0 l/h\* >

-----> Set value -----> ✓

-----> >

The calculated K factor is displayed.

-----> Accept > or Reject ✕

Accept:

-----> ✓ -----> ✓

✓ The settings are accepted.

Reject:

-----> ✓

✓ The input assistant stops.

\* The value set previously appears here.

**9.6.7 Resetting digital input to factory settings**

User level: Installer

→ Switch to Maintenance detailed view.

Factory setting for digital inputs: Binary operating mode

Reset to factory settings ...>

-----> ✓

✓ The settings are accepted.

## 9.6.8 Simulation of a process value on the input module

The user can use this function to set an incoming process value on the input module.

User level: Installer

→ Switch to Maintenance detailed view.

Simulation -----> Status -----> Off\* ▶

-----> Select  ----->

Value -----> 30.25 °C\* ▶

-----> Set value ----->

The settings are accepted.

\* The value set previously appears here.

## 9.7 Setting output module



Before setting the output modules, make the settings in the assigned devices or input modules.

### 9.7.1 Setting analog output

User level: Installer

→ Switch to Parameters detailed view.

#### Setting input (assignment):

→ ① Select device and value which is assigned to the analog output.

→ ② Change name if required.

#### Re ①: Setting input (assignment).

Mapping -----> Configure ...>

The input assistant starts.

-----> None > -----> Select device\* ✓ -----> >  
 -----> AI1\*\* > -----> Select value\*\*\* ✓ -----> >

The selected settings are displayed.

-----> ✓

✓ The device is restarted and the settings are accepted.

\* The connected devices appear.

\*\* The 1st value on the list appears.

\*\*\* The possible values of the selected device appear.

#### Re ②: Change name.

Mapping -----> Name -----> AI1\* >

-----> Set name -----> ✓

✓ The name is set.

\* The value set previously appears here.

**Setting output:**

- ① Set the value of the process input which is assigned to the current of 4 mA.
- ② Set the value of the process input which is assigned to the current of 20 mA.
- ③ Set response time of the filter.
- ④ Change name if required.
- ⑤ Select initial value for error handling (only if assigned device is missing).
- ⑥ Activating diagnostics: To detect an open current loop.

**Re ①, ②: Set value of the process input for 4 mA and 20 mA.**

Output -----> Value at 4 mA -----> -10 °C\* ▶

Output -----> Value at 20 mA -----> 30 °C\* ▶

-----> Set value ----->

The value is set.

\* The value set previously appears here.

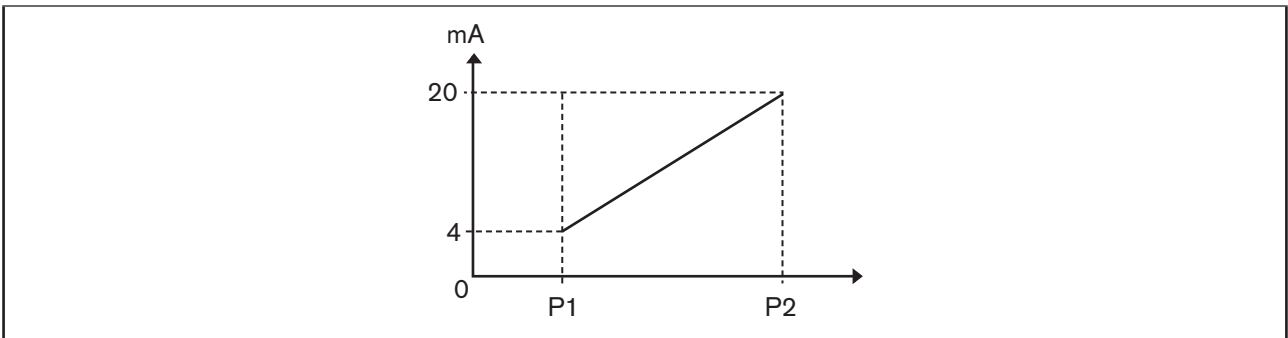

Figure 16: Current 4 - 20 mA depending on the process value

**Re ③: Set filter response time.**

The user uses this function to specify the degree of damping for measured value fluctuations of the analog output.

Output -----> Filter response time -----> 3 s\* ▶

-----> Set value ----->

The filter response time is set.

\* The value set previously appears here.

MAN 1000297454 EN Version: E Status: RL (released | freigegeben) printed: 27.04.2026

**Re ④: Change name.**

Output -----> Name -----> AO2\* ▶

-----> Set name -----> ✓

✓ The name is set.

\* The value set previously appears here.

**Re ⑤: Select initial value for error handling (only if assigned device is missing).**

The user uses this function to select the value which is output for an error message.

Error handling -----> Output value -----> 22.0 mA\* ▶

Possible selection:

- Last valid value
- 22.0 mA
- 20.5 mA
- 3.5 mA

-----> Select value -----> ✓

✓ The initial value for error handling is set.

\* The value set previously appears here.

**Re ⑥: Activate activation flag for diagnostics.**

To detect an open current loop (e.g. broken wire), the diagnostics must be activated.

Diagnostics -----> Activation flag -----> None\* ▶

-----> Set flag -----> ✓

✓ The activation flag is set.

\* The value set previously appears here.

## 9.7.2 Calibrating analog output

User level: Installer

→ Switch to Maintenance detailed view.

### Calibrating analog output with input assistants:

→ Connect a measuring device to the analog output (e.g. a multimeter).

Hardware calibration -----> Wizard -----> Start ...▶

The input assistant starts.

-----> ▶

-----> Measured value -----> 4.24 mA\* ▶

-----> Set measured value of the measuring device -----> ✓

-----> ▶

-----> Measured value -----> 19.91 mA\* ▶

-----> Set measured value of the measuring device -----> ✓

The selected settings are displayed.

-----> ✓

✓ The settings are accepted.

\* The value set previously appears here.

### Manually setting values for analog output:

The user can manually set the values for 4 mA and 20 mA in the menus.

Hardware calibration -----> Value for 4 mA -----> 4.24 mA\* ▶

Hardware calibration -----> Value for 20 mA -----> 19.94 mA\* ▶

-----> Set value -----> ✓

✓ The value is set.

\* The value set previously appears here.

### Calibrating analog output to factory settings

Hardware calibration -----> Reset to factory settings ...▶

The input assistant starts.



-----> ✓

✓ The settings are accepted.

### 9.7.3 Resetting analog output to factory settings

User level: Installer

→ Switch to Maintenance detailed view.

Reset to factory settings  

-----> 

 The settings are accepted.

### 9.7.4 Setting digital output

User level: Installer

→ Switch to Parameters detailed view.

#### Setting input (assignment):

→ ① Select device and value which is assigned to the digital output.

→ ② Change name if required.

**Re ①: Select device and value which is assigned to the digital output.**

Mapping ----->   

-----> **None**  -----> Select device  -----> 

-----> **AI1**  -----> Select value  -----> 

The selected settings are displayed.

-----> 

 The device is restarted and the settings are accepted.

**Re ②: Change name.**

Mapping -----> **Name** -----> **AI1\*** 

-----> Set name -----> 

 The name is set.

\* The value set previously appears here.

**Setting output:**

- ① Select operating mode.
- ② Make settings according to the selected operating mode.

Re ①: Select operating mode:

Output -----> Operating mode -----> Non configured\* >

Possible selection:

Non configured

On-Off

Threshold

PWM

PFM

For the control of actuators with 2 states.

The output state changes as soon as a threshold is reached.

Fast: For the control of a proportional solenoid valve

Slow: For the control of an On-Off actuator

E.g. for the control of a pump

-----> Select operating mode -----> ✓

✓ The operating mode is set.

The required menus appear according to the set operating mode.

\* The value set previously appears here.

**Re ②: On-Off**

Settings in the On-Off operating mode:

- On-Off ① Set the delay duration before switching over the output.
- On-Off ② Select invert output or do not invert output.
- On-Off ③ Change name if required.
- On-Off ④ Select initial value for error handling (only if assigned device is missing).
- On-Off ⑤ Set power reduction (for 4DO PWM 20 kHz only).

Re On-Off ①: Set delay duration before switching over the output.

Output -----> Delay -----> 0 s\* >

-----> Set time -----> ✓

✓ The delay duration is set.

\* The value set previously appears here.

Re On-Off ②: Invert output.

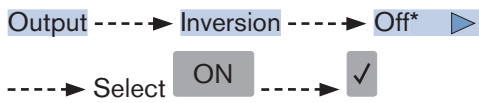

✓ The output is inverted.

\* The value set previously appears here.

Re On-Off ③: Change name.

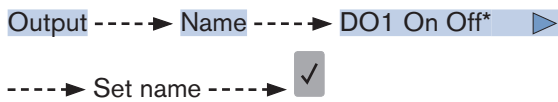

✓ The name is set.

\* The value set previously appears here.

Re On-Off ④: Select initial value for error handling (only if assigned device is missing).

The user uses this function to select the value which is output for an error message.

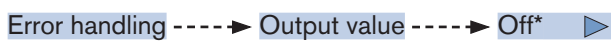

Possible selection:

- Last valid value
- Off
- On

✓ The initial value for error handling is set.

\* The value set previously appears here.

Re On-Off ⑤: Set power reduction (for 4DO PWM 20 kHz only).

→ Activate power reduction.

→ Set time after which the power reduction becomes active (max. 10 s).

→ Set duty cycle (PWM 20 kHz).

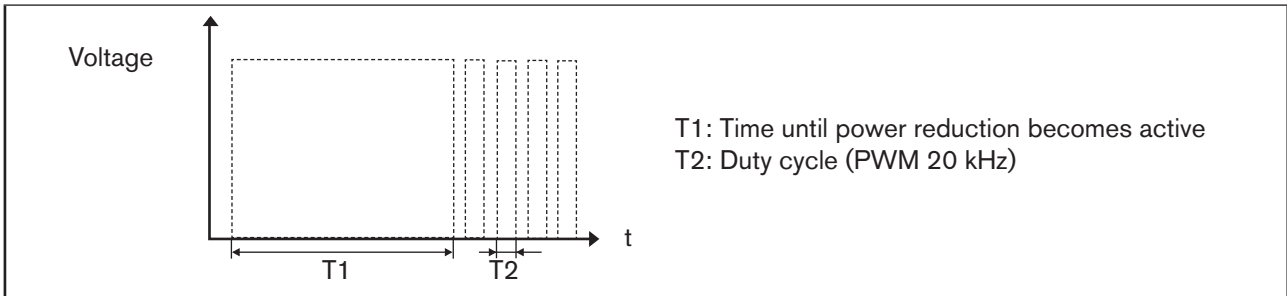
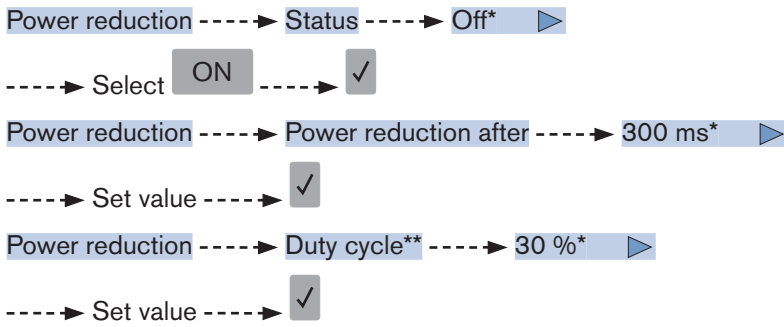

Figure 17: Power reduction

Setting power reduction:



The power reduction is activated and the values are set.

\* The value set previously appears here.

\*\* Ratio between duty cycle and period duration.

**Re ②: Threshold value**

Settings in the threshold value operating mode:

- Threshold value ① Selecting type of threshold: Hysteresis or window.
- Threshold value ② Set lower threshold value.
- Threshold value ③ Set upper threshold value.
- Threshold value ④ Set the delay duration before switching over the output.
- Threshold value ⑤ Select invert output or do not invert output.
- Threshold value ⑥ Change name if required.
- Threshold value ⑦ Select initial value for error handling (only if assigned device is missing).
- Threshold value ⑧ Set power reduction (for 4DO PWM 20 kHz only).

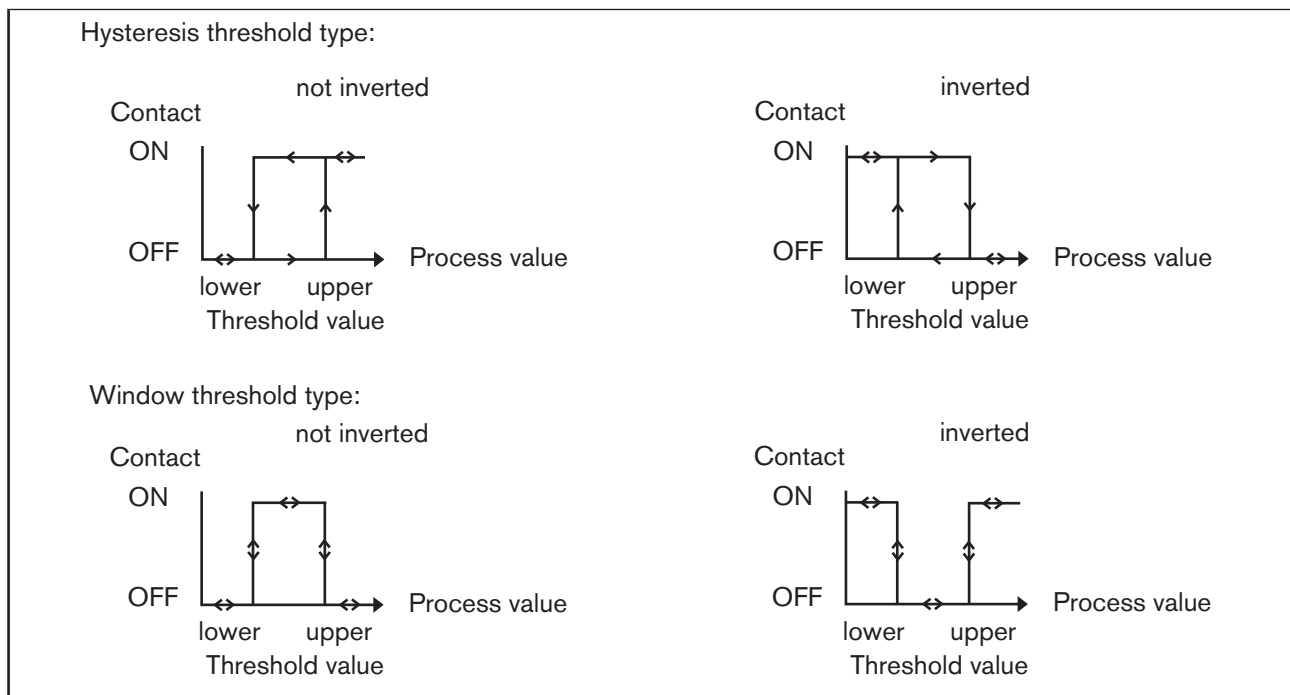

Figure 18: Threshold value operating mode

Re threshold value ①: Select threshold value.

Output -----> Threshold mode -----> Hysteresis\* ▶

Possible selection:

- Hysteresis
- Window

-----> Select threshold value -----> ✓

✓ The threshold value is set.

\* The value set previously appears here.

Re threshold value ②: Set lower threshold value.

Output -----> Lower threshold -----> 0 l/s\* ▶

-----> Set value ----->

The lower threshold value is set.

\* The value set previously appears here.

Re threshold value ③: Set upper threshold value.

Output -----> Upper threshold -----> 1.7 l/s\* ▶

-----> Set value ----->

The upper threshold value is set.

\* The value set previously appears here.

Re threshold value ④: Set lower delay duration.

Output -----> Delay -----> 0 s\* ▶

-----> Set value ----->

The delay duration is set.

\* The value set previously appears here.

Re threshold value ⑤: Invert output.

Output -----> Inversion -----> Off\* ▶

-----> Select  ON ----->

The output is inverted.

\* The value set previously appears here.

Re threshold value ⑥: Change name.

Output -----> Name -----> DO1 On Off\* ▶

-----> Set name ----->

The name is set.

\* The value set previously appears here.

Re threshold value ⑦: Initial value for error handling (only if assigned device is missing).

The user uses this function to select the value which is output for an error message.

Error handling -----> Output value -----> Off\* ▶

Possible selection:

- Last valid value
- Off
- On

-----> Select value -----> ✓

✓ The initial value for error handling is set.

\* The value set previously appears here.

Re threshold value ⑧: Set power reduction (for 4DO PWM 20 kHz only).

→ Activate power reduction.

→ Set time after which the power reduction becomes active (max. 10 s).

→ Set duty cycle (PWM 20 kHz).

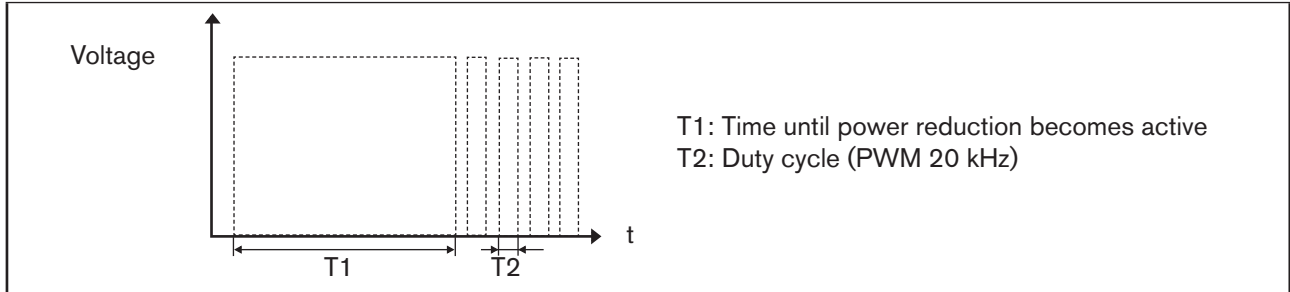

Figure 19: Power reduction

Setting power reduction:

Power reduction -----> Status -----> Off\* ▶

-----> Select ON -----> ✓

Power reduction -----> Power reduction after -----> 300 ms\* ▶

-----> Set value -----> ✓

Power reduction -----> Duty cycle\*\* -----> 30 %\* ▶

-----> Set value -----> ✓

✓ The power reduction is activated and the values are set.

\* The value set previously appears here.

\*\* Ratio between duty cycle and period duration.

Re ②: PWM

Settings in the PWM operating mode:

→ PWM ① Select type of PWM: fast or slow.

Re PWM ①: Select the type of PWM.

Output -----> Mode -----> Fast PWM\* ▶

Possible selection:

- Fast PWM
- Slow PWM

-----> Select type -----> ✓

✓ The type of PWM is set.

\* The value set previously appears here.

Settings for fast PWM selection:

- Fast PWM ① Set value of the output frequency.
- Fast PWM ② Set value of the process input which corresponds to a PWM of 0 %.
- Fast PWM ③ Set value of the process input which corresponds to a PWM of 100 %.
- Fast PWM ④ Select invert output or do not invert output.
- Fast PWM ⑤ Change name if required.
- Fast PWM ⑥ Select initial value for error handling (only if assigned device is missing).

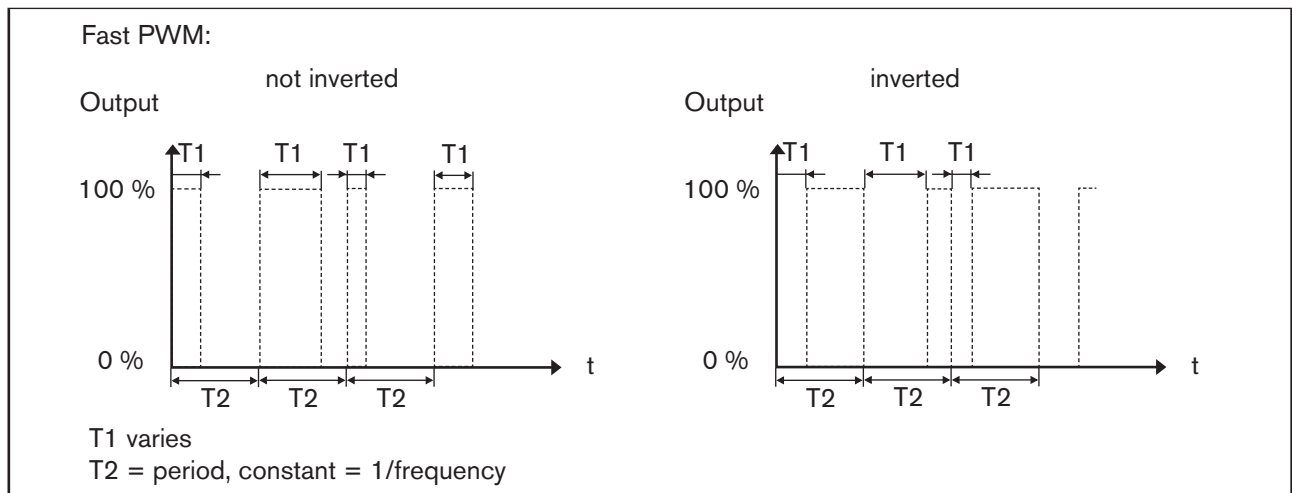

Figure 20: Fast PWM operating mode

Re fast PWM ①: Set output frequency.

Output -----> Frequency -----> 2000 Hz\* ▶

-----> Set value ----->

The output frequency is set.

\* The value set previously appears here.

Re fast PWM ②: Set value of the process input for a PWM of 0 %.

Output -----> Value at 0 % -----> 0 l/s\* ▶

-----> Set value ----->

The value is set.

\* The value set previously appears here.

Re fast PWM ③: Set value of the process input for a PWM of 100 %.

Output -----> Value at 100 % -----> 0 l/s\* ▶

-----> Set value ----->

The value is set.

\* The value set previously appears here.

Re fast PWM ④: Invert output.

Output -----> Inversion -----> Off\* ▶

-----> Select  ON ----->

The output is inverted.

\* The value set previously appears here.

Re fast PWM ⑤: Change name.

Output -----> Name -----> DO1 Percent\* ▶

-----> Set name ----->

The name is set.

\* The value set previously appears here.

Re fast PWM ⑥: Initial value for error handling (only if assigned device is missing).

Error handling -----> Output value -----> Error value\* >

Possible selection:

Last valid value

Error value

-----> Select value -----> ✓

Error handling -----> Error value -----> 0 %\* >

-----> Set value -----> ✓

✓ The error handling is set.

\* The value set previously appears here.

Settings for slow PWM selection:

- Slow PWM ① Set value of period T2.
- Slow PWM ② Set minimum switch-on time T1.
- Slow PWM ③ Set value of the process input which corresponds to a PWM of 0 %.
- Slow PWM ④ Set value of the process input which corresponds to a PWM of 100 %.
- Slow PWM ⑤ Select invert output or do not invert output.
- Slow PWM ⑥ Change name if required.
- Slow PWM ⑦ Select initial value for error handling (only if assigned device is missing).

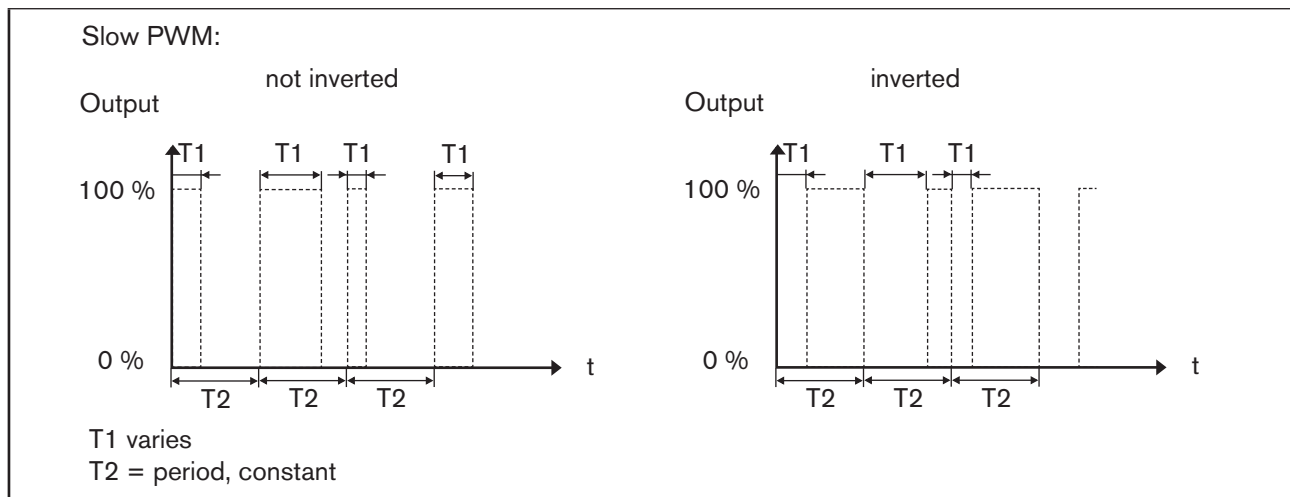

Figure 21: Slow PWM operating mode

Re slow PWM ①: Set value of period T2.

Output -----> Period -----> 60 s\* ▶

-----> Set value -----> ✓

✓ The value is set.

\* The value set previously appears here.

Re slow PWM ②: Set minimum switch-on time T1.

Output -----> Minimum ON time -----> 0.125 s\* ▶

-----> Set value -----> ✓

✓ The value is set.

\* The value set previously appears here.

Re slow PWM ③: Set value of the process input for a PWM of 0 %.

Output -----> Value at 0 % -----> 0\* ▶

-----> Set value ----->

The value is set.

\* The value set previously appears here.

Re slow PWM ④: Set value of the process input for a PWM of 100 %.

Output -----> Value at 100 % -----> 100\* ▶

-----> Set value ----->

The value is set.

\* The value set previously appears here.

Re slow PWM ⑤: Invert output.

Output -----> Inversion -----> Off\* ▶

Select-----> ON ----->

The output is inverted.

\* The value set previously appears here.

Re slow PWM ⑥: Change name.

Output -----> Name -----> DO1 Percent\* ▶

-----> Set name ----->

The name is set.

\* The value set previously appears here.

Re slow PWM ⑦: Initial value for error handling (only if assigned device is missing).

Error handling -----> Output value -----> Error value\* ▶

Possible selection:

Last valid value

Error value

-----> Select value ----->

Error handling -----> Error value -----> 0 %\* ▶

-----> Set value ----->

The name is set.

\* The value set previously appears here.

**Re ②: PFM**

Settings in PFM operating mode:

- PFM ① Select maximum frequency ( $1/T_2$ ) of the pulses.
- PFM ② Select pulse width ( $T_1$ ).
- PFM ③ Set value of the process input which corresponds to the minimum frequency at 0 %.
- PFM ④ Set value of the process input which corresponds to the maximum frequency at 100 %.
- PFM ⑤ Select invert output or do not invert output.
- PFM ⑥ Change name if required.
- PFM ⑦ Select initial value for error handling (only if assigned device is missing).

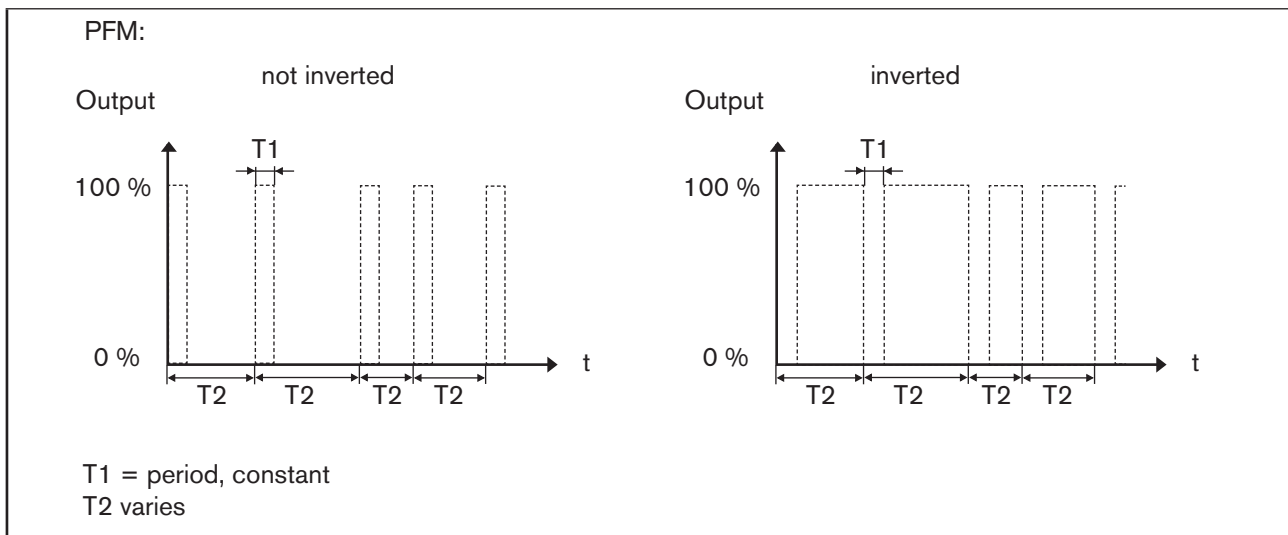

Figure 22: PFM operating mode

Re PFM ①: Set maximum frequency ( $1/T_2$ ).

Output -----> Maximum frequency -----> 180 1/min\* >

-----> Set value -----> ✓

✓ The value is set.

\* The value set previously appears here.

Re PFM ②: Set pulse width ( $T_1$ ).

Output -----> Pulse width -----> 0.2 s\* >

-----> Set value -----> ✓

✓ The value is set.

\* The value set previously appears here.

Re PFM ③: Set value of the process input at the minimum frequency of 0 %.

Output -----> Value at 0 % -----> 0\* ▶

-----> Set value -----> ✓

✓ The value is set.

\* The value set previously appears here.

Re PFM ④: Set value of the process input at the minimum frequency of 100 %.

Output -----> Value at 100 % -----> 100\* ▶

-----> Set value -----> ✓

✓ The value is set.

\* The value set previously appears here.

Re PFM ⑤: Invert output.

Output -----> Inversion -----> Off\* ▶

Select-----> ON -----> ✓

✓ The output is inverted.

\* The value set previously appears here.

Re PFM ⑥: Change name.

Output -----> Name -----> DO1 Percent\* ▶

-----> Set name -----> ✓

✓ The name is set.

\* The value set previously appears here.

Re PFM ⑦: Initial value for error handling (only if assigned device is missing).

Error handling -----> Output value -----> Error value\* ▶

Possible selection:

Last valid value

Error value

-----> Select value -----> ✓

Error handling -----> Error value -----> 0 %\* ▶

-----> Set value -----> ✓

✓ The name is set.

\* The value set previously appears here.

## 9.7.5 Manually actuating output module

The user can use this function to set a value on the output module.

User level: Installer

→ Switch to Maintenance detailed view.

MANUAL operating state -----> Status -----> Off\* ▶

-----> Select  ----->

Value -----> 10 mA\* ▶

-----> Set value ----->

The settings are accepted.

\* The value set previously appears here.

## 10 DISPLAY ELEMENTS

The LED display elements provide information about the device status.

### Display element on the I/O module Type ME24

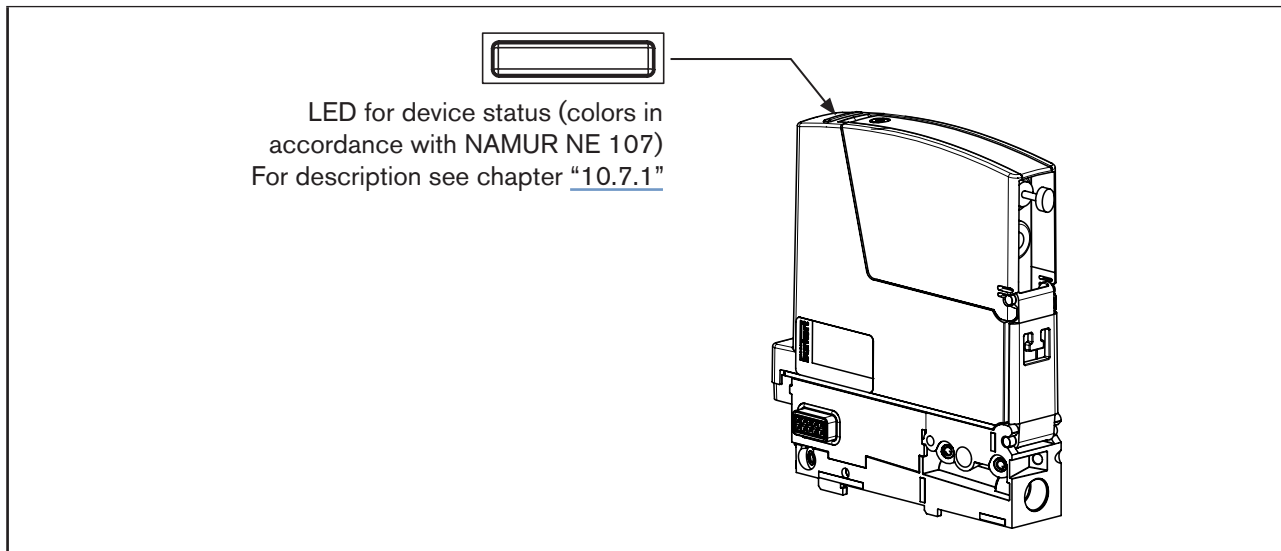

Figure 23: Display element, I/O module Type ME24

### Display element on the display, if available



Figure 24: Display element, display

### 10.7.1 Display of device status

The LED for device status and the NAMUR light element changes color in accordance with NAMUR NE 107.

If several device statuses exist simultaneously, the device status with the highest priority is displayed. The priority is determined by the severity of the deviation from controlled operation (red LED = failure = highest priority).

Status display in accordance with NE 107, edition 2006-06-12			
Color	Color Code	Description	Meaning
Red	5	Failure, error or fault	Due to a malfunction in the device or on its periphery, controlled operation is not possible.
Orange	4	Function check	The device is being worked on; controlled operation is therefore temporarily not possible. e. g. Operating mode HAND or simulation.
Yellow	3	Outside the specification	The ambient conditions or process conditions for the device are outside the specified area.
Blue	2	Maintenance requirement	The device is in controlled operation, however function is briefly restricted. → Maintain device.
Green	1	Diagnostics active	Device is operating faultlessly. Status changes are shown in color. Messages are transmitted via any connected field bus.
White	0	Diagnostics inactive	Device is switched on. Status changes are not shown. Messages are not transmitted via any connected field bus.

Table 13: Description of the colors

#### Lighting state of the LED for device status:

Display	Description	Meaning
Lighting state	Off	No power is supplied to the device.
	Is lit green	Normal Device is in controlled operation.
	Flashing rapidly	Identification Is used for identification of a device in the bus network. The device is selected using the "Bürkert-Communicator" software or on a display.

Table 14: Description of the lighting state for device status

# 11 MAINTENANCE

## 11.1 Safety instructions

### **WARNING!**

Risk of injury from improper maintenance.

- ▶ Maintenance may be carried out only by trained technicians and with the appropriate tools.
- ▶ Secure system against unintentional activation.
- ▶ Following maintenance, ensure a controlled restart.

## 11.2 Replacing devices

### 1. Take safety measures:

→  Switch off supply voltage!

### 2. Remove cables from sensors and actuators.

→ If the cable has been secured to the housing for strain relief, remove cable from securing device.

→ Unscrew fastening screw at the cover of Type ME24.

→ Open and remove cover.

→ Remove connection terminal.

→ Press push-in contacts onto the connection terminal and pull out wires.

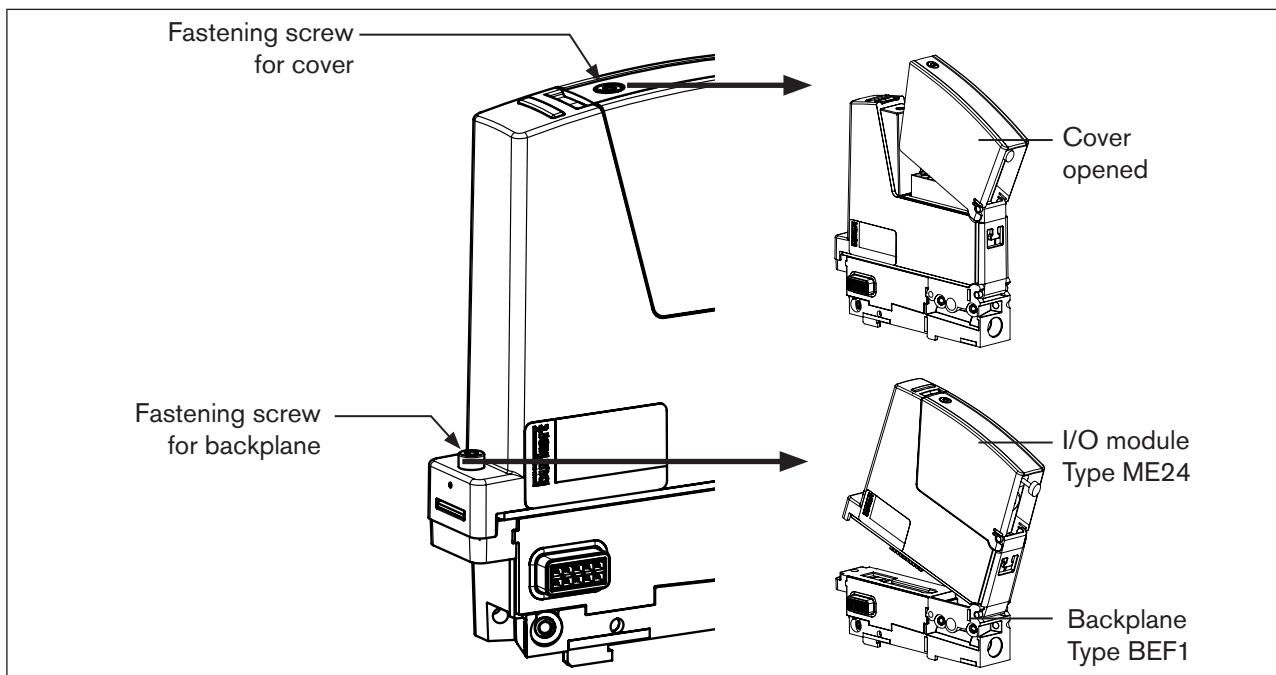

Figure 25: Replacing devices, I/O module Type ME24

### 3. Remove I/O module Type ME24 from the backplane Type BEF1.

→ Unscrew fastening screw on the rear of the housing and remove Type ME24.

### 4. Change the memory card if required

The memory card is on the underside of the device.

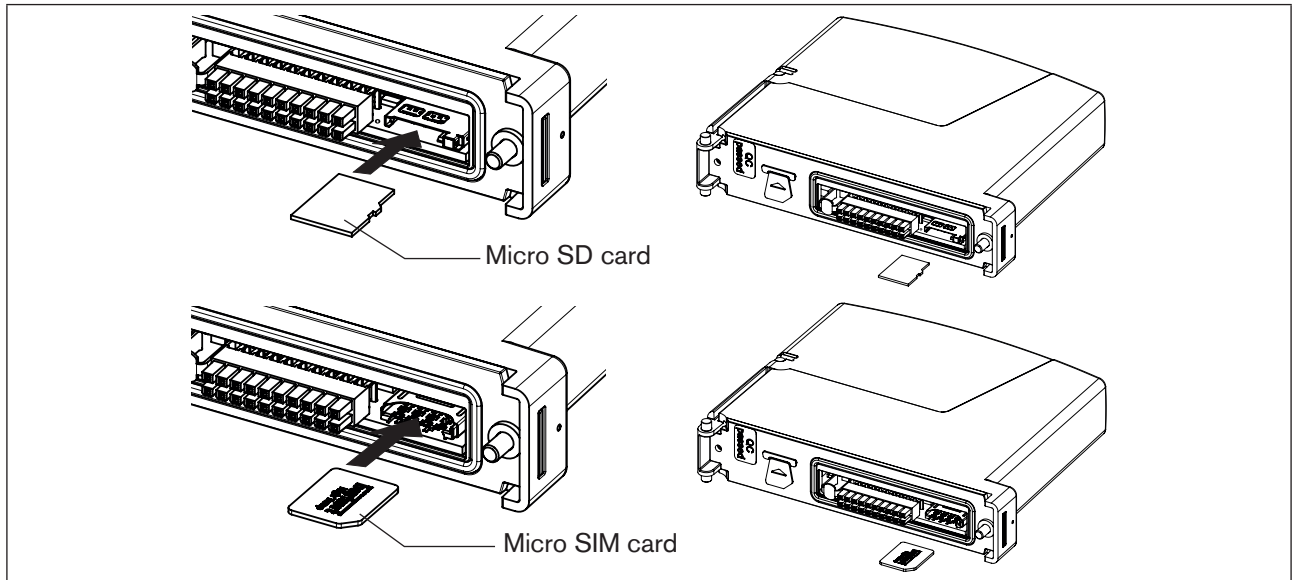

Figure 26: Replacing the memory card, I/O module ME24

Removing the memory card:

→ Micro SD card: Press on the edge of the engaged micro SD card to unlock it.

→ Pull out memory card.

Inserting memory card into the replacement device:

⚠ Insert memory card in the right direction.

→ Push memory card into the card holder of the replacement device.

Micro SD card: Ensure that the micro SD card clicks into place.

### 5. Install replacement device.

→ Insert hinge part of Type ME24 into the counter piece of backplane Type BEF1.

→ Press Type ME24 fully onto the backplane.

→ Tighten fastening screw for backplane. Maximum torque 1 Nm.

→ Unscrew fastening screw on the cover of the Type ME24 (hexagon socket 2.5 mm).

→ Open and remove cover.

→ Pull out connection terminals.

→ Insert cables of the external sensors and actuators through the opening on the back of the cover.

→ Connect wires of the external sensors and actuators to the connection terminals (plug configuration see chapter "7.3.1 Plug configuration and wiring").

→ Reconnect connection terminal.

→ Close cover and tighten fastening screw. Maximum torque 1 Nm.

✔ Type ME24 is connected to the power supply of the backplane Type BEF1.

#### Securing the cables (strain relief):

To relieve the strain, fix the cables to the recess with a cable clip.

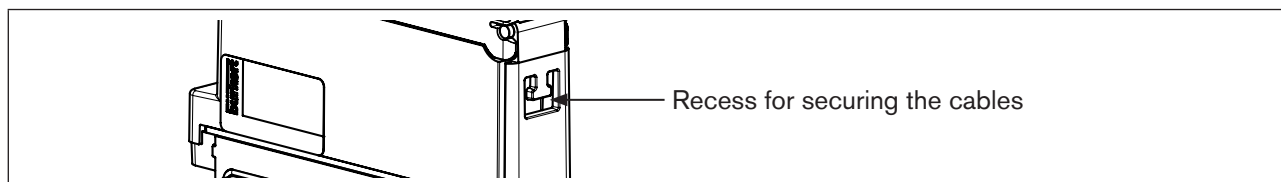

Figure 27: Strain relief for cables, I/O module Type ME24

## 11.3 Replacing the memory card

The I/O module ME24 has a removable data storage in the form of a memory card on which the device-specific data is stored.

On modules 2AO, 2DO and 4DO this memory card is a micro SD card. On module 2AI, 2DI a Micro SIM card.

The device is delivered with the memory card inserted.

The memory card can be used to replace specific data on devices which have the same identification number. For example, for transferring the data from a defective device to a new device.

The memory card stores e.g. the baud rate, the address and/or the configuration of the device process values.

If there is device-specific data on the inserted memory card during the restart, the device will take over this data.

If there is no device-specific data on the memory card, the device will store its own data on it.

#### NOTE!

Do not use a standard memory card for the device. Purchase the memory card for Type ME24 from your Bürkert sales department.  
See chapter "[12 Accessories](#)".

The micro SD card must be formatted with the FAT12/16/32 file system. If this is not the case, the card will not be detected when it is inserted.

#### Replacing the memory card:

The memory card is on the underside of the device.

##### 1. Take safety measures:

→ ⚠ Switch off supply voltage!

##### 2. Remove I/O module Type ME24 from the backplane Type BEF1.

→ Unscrew fastening screw on the rear of the housing and remove Type ME24.

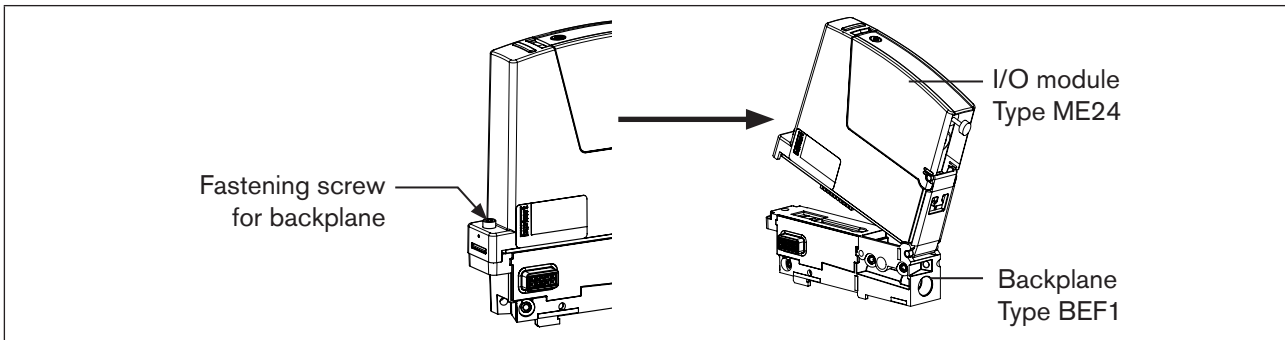

Figure 28: Replacing devices, I/O module Type ME24

### 3. Removing the memory card:

- Micro SD card: Press on the edge of the engaged memory card to release it.
- Pull out memory card.

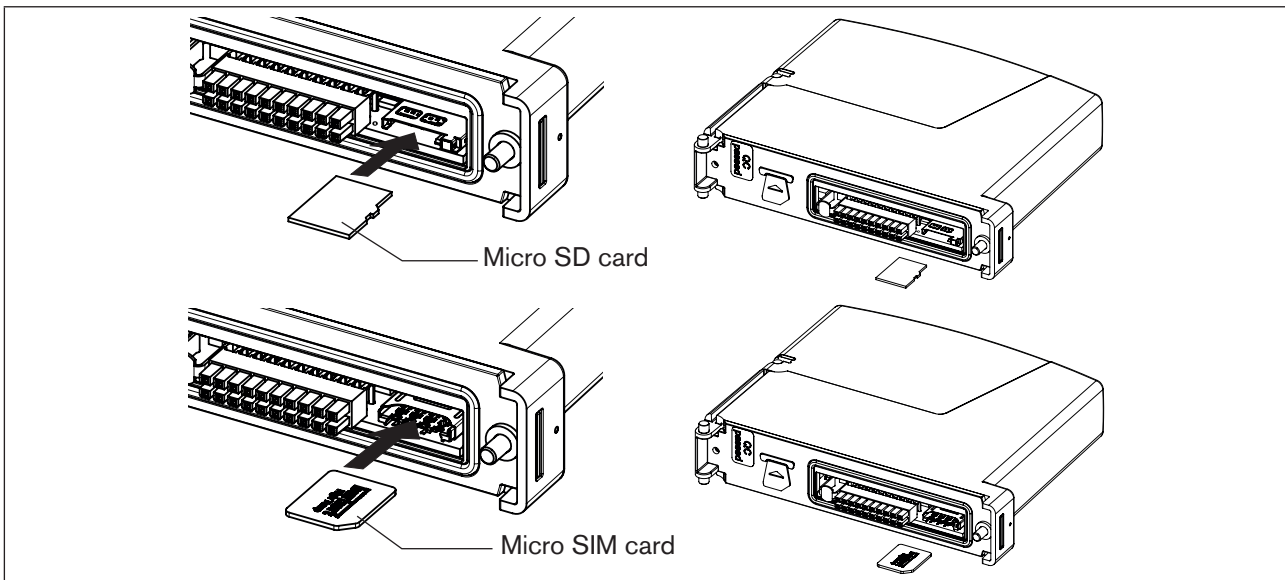

Figure 29: Replacing the memory card, I/O module ME24

### 4. Inserting memory card into the device:

- ⚠ Insert memory card in the right direction.
- Push memory card into the card holder of the device.  
Ensure that the memory card clicks in place.

### 5. Installing I/O module:

- Insert hinge part of Type ME24 into the counter piece of backplane Type BEF1.
- Press Type ME24 fully onto the backplane.
- Tighten fastening screw for backplane. Maximum torque 1 Nm.
- ✔ The memory card is replaced and Type ME24 connected to the backplane Type BEF1.

## 11.4 Troubleshooting

Problem	Possible cause	Procedure
LED is not lit.	No power is supplied to the device.	Connect device to power supply.
LED goes out periodically.	The supply voltage fails periodically: The device performs a reset.	Use power supply with adequate power.
	The voltage drop in the connection cable is too great.	Increase supply voltage (Attention: do not exceed maximum permitted voltage). Increase cable cross-section. Reduce cable length.
LED is lit red.	Assigned device is missing (for 2AO, 2DO and 4DO PWM 20 kHz only).	Check assigned device, e.g. defective device, faulty bus connection, no supply voltage, etc.
	bus connection not available	Check bus network.
	Open current loop (e.g. Broken wire) detected (only on the analog output of module 2AO, 2DO).	Check signal lines of the analog outputs.
Replacement device does not take over values from the memory card taken out of the defective device.	The device identification numbers of the replacement device and the defective device differ.	Only values having the same identity number can be transferred between devices.
	The memory card is defective. The device cannot write any values to the memory card.	Replace the memory card and retry transferring the parameters from the defective device to the memory card. (See chapter <a href="#">“11.3 Replacing the memory card”</a> ).
Replacement device does not take over all values from the memory card taken out of the defective device.	The EDS device description between the replacement device and the defective device differs.	Only existing values of the defective device can be transferred to the replacement device. Set new values of the replacement device using the “Bürkert-Communicator” software.

Table 15: Troubleshooting

## 12 ACCESSORIES



### CAUTION!

**Risk of injury and/or damage by the use of incorrect parts.**

Incorrect accessories and unsuitable spare parts may cause injuries and damage the device and the surrounding area.

- ▶ Use original accessories and original spare parts from Bürkert only.

Accessories	Order no.
büS stick with cable (socket M12)	00772551
büS stick set (including power supply unit) and "Bürkert Communicator" software	00772426
Micro SD card	00919877
Micro SIM card	00919902

## 13 PACKAGING AND TRANSPORT

### NOTE!

#### Transport damage.

Inadequately protected devices may be damaged during transportation.

- Protect the device against moisture and dirt in shock-resistant packaging during transportation.
- Prevent the temperature from exceeding or dropping below the permitted storage temperature.

## 14 STORAGE

### NOTE!

#### Incorrect storage may damage the device.

- Store the device in a dry and dust-free location.
- Storage temperature:  $-40\text{ °C}$ – $+60\text{ °C}$ .

## 15 DISPOSAL

### NOTE!

#### Damage to the environment caused by parts contaminated with media.

- Dispose of the device and packaging in an environmentally friendly manner.
- Observe applicable disposal and environmental regulations.



Observe the national waste disposal regulations.





