

## Type 8798 Remote Sensor

### Address

Bürkert Fluid Control Systems  
Christian-Bürkert-Str. 13-17  
D-74653 Ingelfingen  
Tel. +49 (0)7940 10-91 111  
E-mail: info@burkert.com  
International: country.burkert.com

Manuals on the Internet: [country.burkert.com](http://country.burkert.com)

© Bürkert Werke GmbH & Co. KG, 2025  
Supplement 2511/00\_US-en\_60043956 / Original EN



## Important information for devices with UL approval

### 1 Intended use

**Non-intended use of the control head Type 8798 may be a hazard to people, nearby equipment and the environment.**

**The device is designed to be mounted on pneumatic actuators for measuring distance on control valves. Operation is possible only in combination with position controllers.**

- ▶ Do not use the device outdoors without protection from the weather.
- ▶ Use according to the authorized data, operating conditions and conditions of use specified as described in this document.
- ▶ The device may be used only in conjunction with third-party devices and components recommended and authorized by Bürkert.

#### Explosion hazard!

Only those devices are permitted to be installed in a potentially explosive atmosphere/hazardous (classified) location that bear the corresponding labeling for the respective area.

### 2 Basic safety instructions

**⚠** The operator is responsible for observing the location-specific safety regulations, also with reference to the personnel.

#### Risk of injury from high pressure in the equipment/device

- ▶ Before working on equipment or device, switch off the pressure and deaerate/drain lines.

#### General hazardous situations:

To prevent injury, ensure:

- ▶ That the system cannot be activated unintentionally.
- ▶ Installation and repair work may be carried out by authorized technicians only and with the appropriate tools.

To prevent damage to property of the device, ensure:

- ▶ Do not feed any aggressive or flammable media into the pilot air port.
- ▶ Do not feed any liquids into the pilot air port.
- ▶ When unscrewing and screwing in the body casing or the transparent cap, do not hold the actuator of the process valve but the connection housing of the device.
- ▶ Do not put any loads on the body (e.g. by placing objects on it or standing on it).
- ▶ Do not make any external modifications to the device bodies. Do not paint the body parts or screws.

### 3 Operating conditions

Altitude	restricted to max. 2000 m above sea level
Relative air humidity	max. 90% at 55 °C (non condensing)
Ambient temperature	see type label

#### Degree of protection

evaluated by the manufacturer	IP65/IP67 according to EN 60529 <sup>1)</sup>
evaluated by UL	UL Type 4x Rating indoor only <sup>1)</sup>

### 4 Pneumatic data

Only if installed on process valves with internal air supply Type 2103, 2300 and 2301

Pressure range	0...7 bar (0...101.5 psi)
Temperature range of compressed air	see the process valve operating instructions

### 5 Electrical data

- ⚠** The device must be supplied by one of the following:
- a) Limited Energy Circuit (LEC) according to UL/ IEC 61010-1
  - b) Limited Power Source (LPS) according to UL/ IEC 60950
  - c) SELV/ PELV with UL Recognized Overcurrent Protection dimensioned according to UL/ IEC 61010-1 Table 18
  - d) NEC Class 2 power source

Protection class	III as per DIN EN 61140 (VDE 0140-1)
Supply voltage	(via the positioner Type 8791 or Type 8792/8793)
Linear Remote Sensor	24 V $\overline{\text{---}}$ $\pm$ 10%

<sup>1)</sup> Only if cables, plugs and sockets have been connected correctly and in compliance with the exhaust air concept

## 6 Installation of the linear Remote Sensor Type 8798

### 6.1 Attachment to process valves with internal air supply (series 2103, 2300 and 2301)

#### NOTE!

When mounting on process valves with a welded body, follow the installation instructions in the operating instructions for the process valve.

#### 1. Install switch spindle

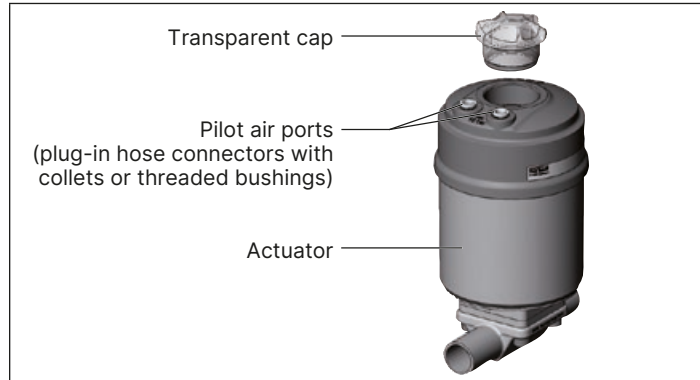

Fig. 1: Installation of linear Remote Sensor, series 2103, 2300 and 2301

- ▶ Unscrew the transparent cap on the actuator and unscrew the position display (yellow cap) on the spindle extension (if present).
- ▶ For version with plug-in hose connector, remove the collets (white nozzles) from both pilot air ports (if present).

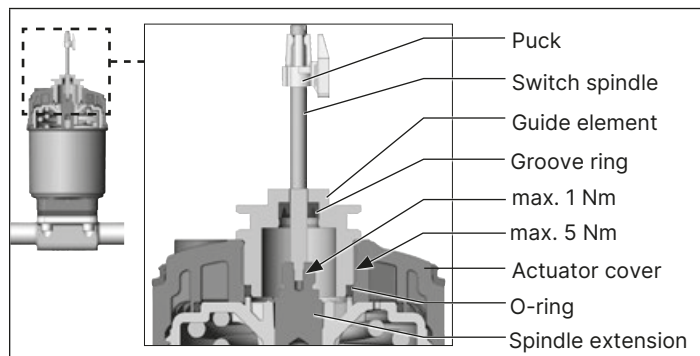

Fig. 2: Installation of the switch spindle, series 2103, 2300 and 2301

#### NOTE!

Improper installation may damage the groove ring in the guide element.

The groove ring is already pre-assembled in the guide element and must be "locked into position" in the undercut.

- ▶ When installing the switch spindle, do not damage the groove ring.

- ▶ Push the switch spindle through the guide element.

#### NOTE!

Screw locking paint may contaminate the groove ring.

- ▶ Do not apply any screw locking paint to the switch spindle.

- ▶ To secure the switch spindle, apply some screw locking paint (Loctite 290) in the tapped bore of the spindle extension in the actuator.
- ▶ Check that the O-ring is correctly positioned.
- ▶ Screw the guide element to the actuator cover (maximum torque: 5 Nm).

- ▶ Screw switch spindle onto the spindle extension. To do this, there is a slot on the upper side (maximum torque: 1 Nm).
- ▶ Push puck onto the switch spindle and lock into position.

#### 2. Install sealing rings

- ▶ Pull the form seal onto the actuator cover (smaller diameter points upwards).
- ▶ Check that the O-rings are correctly positioned in the pilot air ports.



When the Remote Sensor is being installed, the collets of the pilot air ports must not be fitted to the actuator.

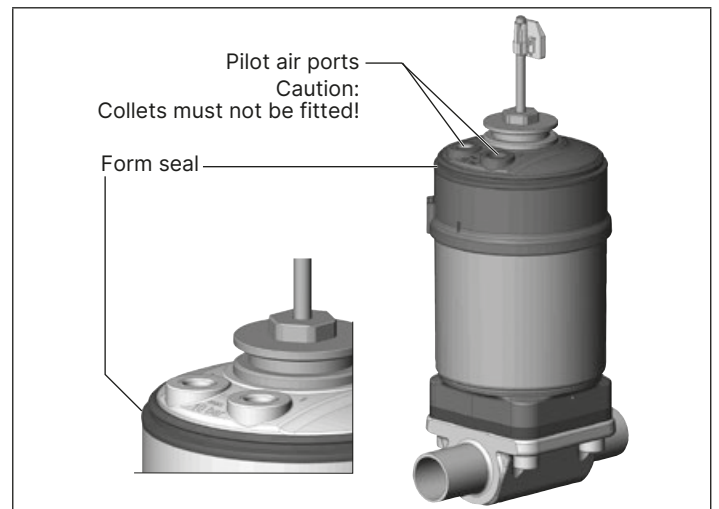

Fig. 3: Installation of the sealing rings, series 2103, 2300 and 2301

#### 3. Install linear Remote Sensor

- ▶ Align the puck and the Remote Sensor in such a way that
  1. the puck engages in the guide rail of the Remote Sensor and
  2. the connection pieces of the Remote Sensor engage in the pilot air ports of the actuator (see Fig. 4)

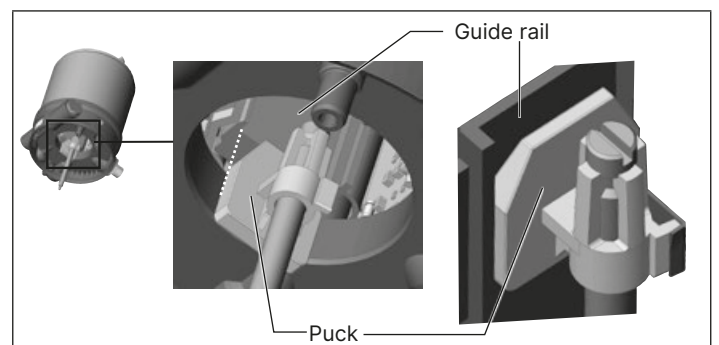

Fig. 4: Aligning the puck

- ▶ Push the Remote Sensor without turning it onto the actuator until no gap is visible on the form seal.
- ▶ Attach the Remote Sensor to the actuator using the two side fastening screws. In doing so, tighten the screws only hand-tight (max. torque: 1.5 Nm).

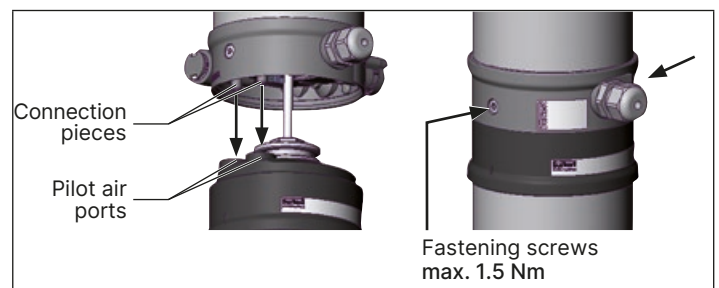

Fig. 5: Installation of linear Remote Sensor, series 2103, 2300 and 2301

## 6.2 Attachment to process valves to series 26xx and 27xx

### 1. Install switch spindle

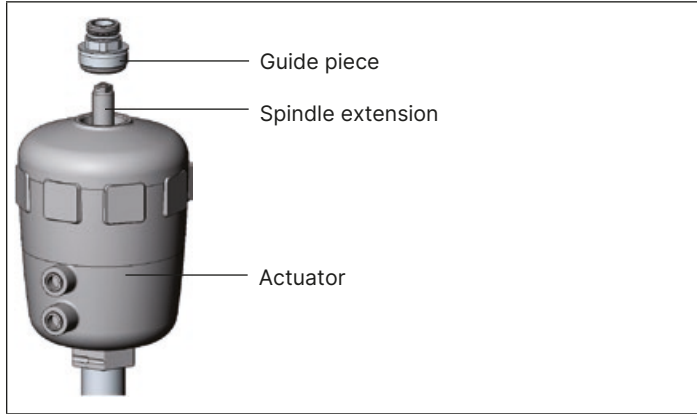

Fig. 6: Installing the switch spindle, series 26xx and 27xx - 1

- ▶ Unscrew the already fitted guide piece from the actuator (if present).
- ▶ Remove intermediate ring (if present).
- ▶ Press the O-ring downwards into the cover of the actuator.

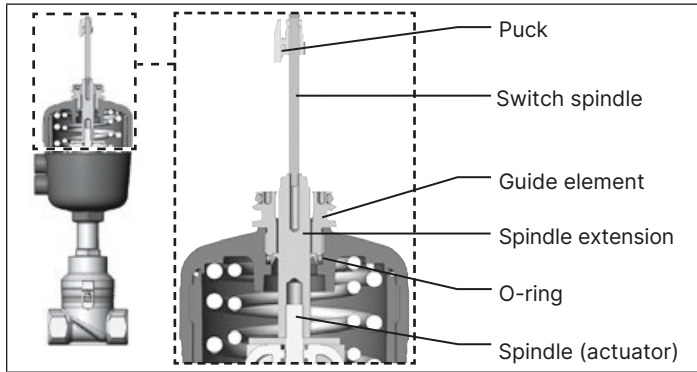

Fig. 7: Installing the switch spindle, series 26xx and 27xx - 2

- ▶ Actuator size 125 and bigger: remove existing spindle extension and replace with the new one. To do this, apply some screw locking paint (Loctite 290) in the tapped bore of the spindle extension.
- ▶ Screw the guide element into the cover of the actuator using a face wrench<sup>2)</sup> (torque: 8.0 Nm).
- ▶ To secure the switch spindle, apply some screw locking paint (Loctite 290) to the thread of the switch spindle.
- ▶ Screw the switch spindle onto the spindle extension. To do this, there is a slot on the upper side (maximum torque: 1 Nm).
- ▶ Push the puck onto the switch spindle until it engages.

### 2. Install linear Remote Sensor

- ▶ Push the Remote Sensor onto the actuator. The puck must be aligned in such a way that it is inserted into the guide rail of the Remote Sensor.

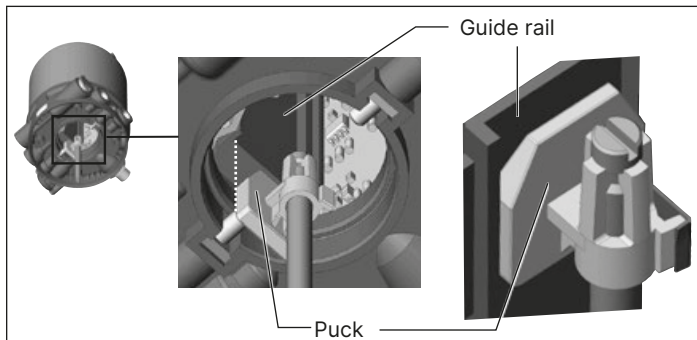

Fig. 8: Aligning the puck

<sup>2)</sup> Journal Ø: 3 mm; journal gap: 23.5 mm

- ▶ Press the Remote Sensor all the way down as far as the actuator and turn it into the required position.

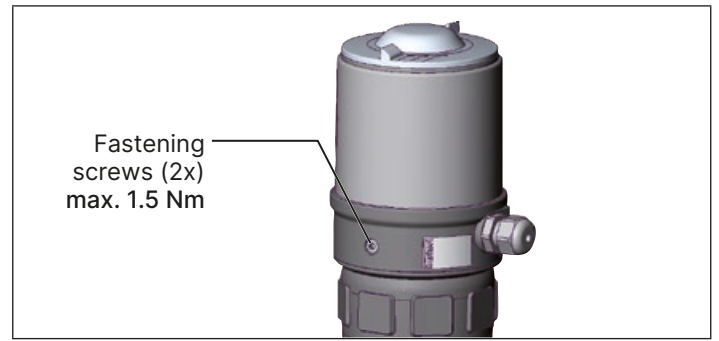

Fig. 9: Installing the linear Remote Sensor

- ▶ Attach the Remote Sensor to the actuator using the two side fastening screws. In doing so, tighten the fastening screws hand-tight only (maximum torque: 1.5 Nm).

## 7 Pneumatic connection

### 7.1 Pneumatic connection of the Remote Sensor with internal air supply (Type 2103, 2300 and 2301)

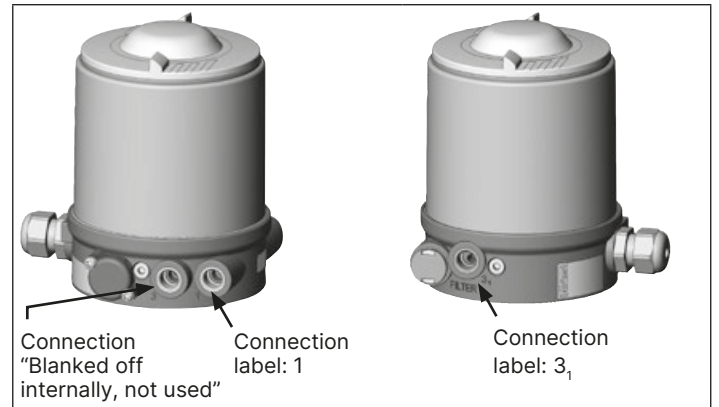

Fig. 10: Pneumatic connection with internal air supply

#### Control functions A and B (single-acting actuators):

- ▶ Connect the working connection A1 or A2<sup>3)</sup> of the positioner Type 8791 or Type 8792/8793 to the connection (1) using a hose.
- ▶ Attach the exhaust airline or a silencer to the connection (3<sub>1</sub>).

#### Control function I (double-acting actuators):

- ▶ Connect working connections A1 and A2 to the respective chambers of the Remote Sensor.

Connection for Remote Sensor	Actuator
3 <sub>1</sub>	upper chamber of the actuator
1	lower chamber of the actuator

Tab. 1: Pneumatic connection - control function I

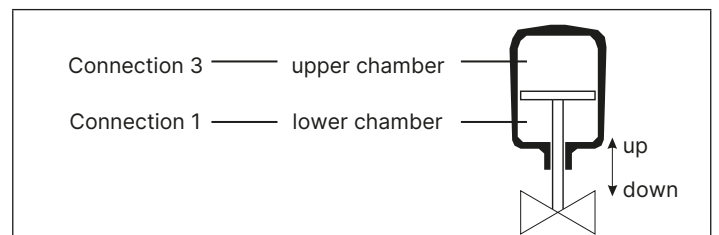

Fig. 11: Pneumatic connection - control function I

<sup>3)</sup> In line with desired safety position (see operating instructions Type 8791 or Type 8792/8793)

## 7.2 Pneumatic connection for process valves belonging to series 26xx and 27xx

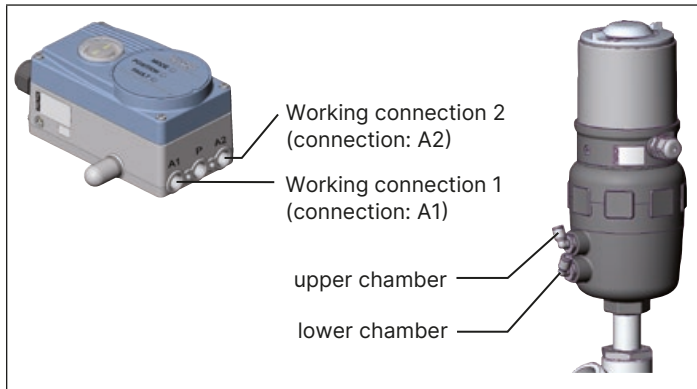

Fig. 12: Pneumatic connection series 26xx and 27xx

### Control function A (single-acting actuator):

- ▶ Connect the working connection A1 or A2<sup>4)</sup> of the positioner Type 8791 or Type 8792/8793 to the lower chamber of the actuator using a hose.
- ▶ Attach the exhaust airline or a silencer to the upper chamber.

### Control function B (single-acting actuator):

- ▶ Connect the working connection A1 or A2<sup>4)</sup> of the positioner Type 8791 or Type 8792/8793 to the upper chamber of the actuator using a hose.
- ▶ Attach the exhaust airline or a silencer to the lower chamber.

### Control function I (double-acting actuators):

- ▶ Connect working connections A1 and A2 to the respective chambers of the actuator.

## 8 Electrical connection to the positioner Type 8791 or Type 8792/8793

- ▶ If necessary, shorten the cable of the Remote Sensor and connect it to the M12 cable gland on the positioner Type 8791 or Type 8792/8793.
- ▶ Connect the 4 wires of the cable, as described in Tab. 2 and in the operating instructions of the positioner Type 8791 or Type 8792/8793, to the appropriate terminals (Chapter „Terminal assignment for external position sensor“).

TERM	Wire color for cable type		Configuration	External circuit 8791 or 8792/8793
	1	2		
1	white	black	Supply sensor -	—○ S -
2		brown	Supply sensor +	—○ S +
3	yellow	orange	Serial interface B cable	—○ B
4	green	red	Serial interface A cable	—○ A

Tab. 2: Wire color - configuration with screw-type terminals

### 8.1 Terminal configuration linear Remote Sensor

#### NOTE!

Breakage of the pneumatic connection pieces due to rotational impact.

- ▶ When unscrewing the body casing, do not hold the actuator of the process valve but the connection housing.

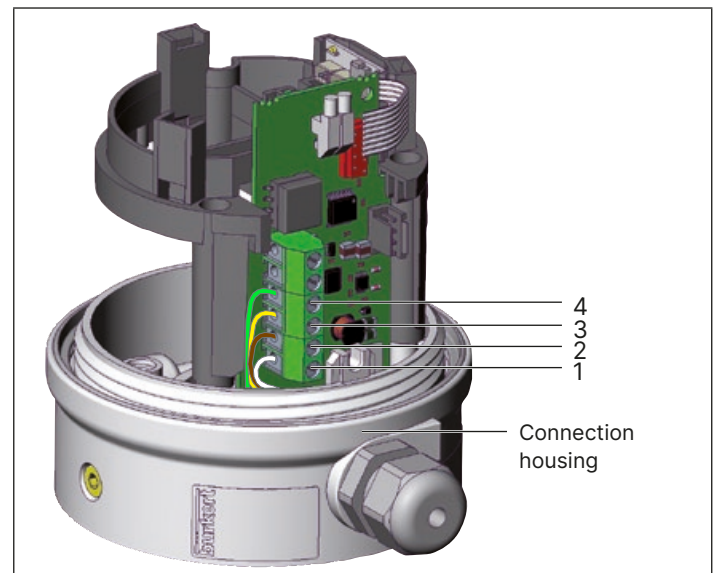

Fig. 13: Terminal configuration linear Remote Sensor

<sup>4)</sup> In line with desired safety position (see operating instructions Type 8791 or Type 8792/8793)