

MODELS BA1 & BL1

BACK PRESSURE / RELIEF REGULATORS

SECTION I

I. DESCRIPTION AND SCOPE

Models BA1 and BL1 are back pressure/relief regulators used to control upstream (inlet or P_1) pressure. Inlet and Outlet sizes - 1/2" (DN 15) and 3/4" (DN20) with Tri-Clamp® connections. Each model incorporates electro-polished stainless steel construction. Refer to Technical Bulletin BA1/BL1-TB for specific design conditions and selection recommendations.

⚠ CAUTION

This is not a safety device and must not be substituted for a code approved pressure safety relief valve or rupture disc.

SECTION II

II. INSTALLATION

1. An inlet block valve should be installed upstream of the regulator.
2. If service application is continuous such that shutdown is not readily accomplished, it is recommended that an inlet block valve, outlet block valve, and a manual bypass valve be installed.
3. An inlet pressure gauge should be located approximately ten pipe diameters upstream, and within sight.

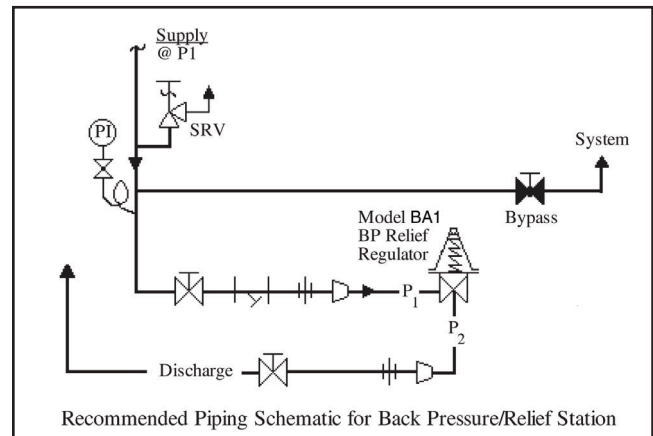

4. All installations should include an upstream relief device if the inlet pressure could exceed the pressure rating of any equipment or the maximum inlet pressure rating of the unit.
5. Flow Direction: Install so the flow direction matches the arrow stamped on the body. Connect the inlet pressure to the body side connection. Fluid will relieve out of the bottom connection if BA1 - angle design.
6. Install unit with spring chamber (2) in the vertical position to allow for proper draining.

⚠ WARNING

The maximum inlet pressure is equal to 1.2 times the larger number of the stated range spring on the nameplate, and is the recommended "upper operative limit" for the sensing diaphragm. Higher pressures could damage the diaphragm. (Field hydrostatic tests frequently destroy diaphragms. DO NOT HYDROSTATIC TEST THROUGH AN INSTALLED UNIT; ISOLATE FROM TEST.)

⚠ CAUTION

Installation of adequate overpressure protection is recommended to protect the regulator from overpressure and all downstream equipment from damage in the event of regulator failure.

SECTION III

III. PRINCIPLE OF OPERATION

1. Movement occurs as pressure variations register on the diaphragm. The registering pressure is the inlet, P_1 , or upstream pressure. The range spring opposes diaphragm movement. As inlet pressure drops, the range spring pushes the diaphragm

down, closing the port; as inlet pressure increases, the diaphragm pushes up and the port opens.

2. A complete diaphragm failure will cause the regulator to fail close and process fluid will discharge from the spring chamber vent hole.

SECTION IV

IV. START-UP

1. Start with the block valves closed. A bypass valve may be used to maintain inlet pressure in the upstream system without changing the following steps.
2. Relax the range spring by turning the adjusting screw counter clockwise (CCW) a minimum of three (3) full revolutions. This reduces the inlet (upstream) pressure setpoint.
3. If it is a "hot" piping system, and equipped with a bypass valve, slowly open the bypass valve to pre-heat the system piping and to allow slow expansion of the piping. Closely monitor inlet (upstream) pressure via gauge to ensure not over-pressurizing. **NOTE:** *If no bypass valve is installed, extra caution should be used in starting up a cold system; i.e. do everything slowly.*
4. Crack open the inlet (upstream) block valve.
5. Slowly open the outlet (downstream) block valve observing the inlet (upstream) pressure gauge. Determine if the regulator is flowing. If not, slowly rotate the regulator adjusting screw counter clockwise (CCW) until flow begins.
6. Continue to slowly open the outlet (downstream) block valve until fully open.

7. Observing the inlet (upstream) pressure gauge, rotate the adjusting screw clockwise (CW) slowly until the inlet pressure begins to rise. Rotate CW until the desired setpoint is reached.
8. Continue to slowly open the inlet (upstream) block valve. If the inlet (upstream) pressure exceeds the desired setpoint pressure, rotate the adjusting screw CCW until the pressure decreases.
9. When flow is established steady enough that both the outlet and inlet block valves are fully open, begin to slowly close the bypass valve, if installed.
10. Develop system flow to a level near its expected normal rate, and reset the regulator setpoint by turning the adjusting screw CW to increase inlet pressure, or CCW to reduce inlet pressure.
11. Reduce system flow to a minimum level and observe setpoint. Inlet pressure will rise from the setpoint of Step 9. (Ensure that this rise does not exceed the stated upper limit of the range spring by greater than 20% i.e. 20-50 psig (1.4 - 3.4 Barg) range spring, at maximum flow the inlet pressure should not exceed 1.2 x 50 psig (3.4 Barg), or 60 psig (4.1 Barg). If it does, consult factory).
12. Increase flow to maximum level, if possible. Inlet (upstream or P_1) pressure should fall off. Readjust setpoint as necessary at the normal flow rate.

SECTION V

V. SHUTDOWN

1. On systems with a bypass valve, and where system pressure is to be maintained as the regulator is shut down, slowly open the bypass valve while closing the inlet (upstream) block valve. Fully close the inlet (upstream) block valve. (When on bypass, the system pressure must be constantly observed and manually regulated. Close the outlet (downstream) block valve.



CAUTION

Do not walk away and leave a bypassed regulator unattended.

2. If the regulator and system are to both be shut down, slowly close the inlet (upstream) block valve. Close the outlet (downstream) valve only if regulator removal is required.

SECTION VI

VI. MAINTENANCE

WARNING

SYSTEM UNDER PRESSURE. Prior to performing any maintenance, isolate the regulator from the system and relieve all pressure. Failure to do so could result in personal injury.

A. General:

1. Maintenance procedures hereinafter are based upon removal of the regulator unit from the pipeline where installed.
2. Owner should refer to owner's procedures for removal, handling, cleaning and disposal of nonreusable parts.
3. Refer to Figures 1 and 2 for the basic regulator, item number reference ().

B. Maintenance:

1. Secure the body (1) in a soft-jaw vise using the flats on the body. Orient the knob (3) upwards.

WARNING

SPRING UNDER COMPRESSION. Prior to removing spring chamber, relieve spring compression by backing out the adjusting screw. Failure to do so may result in flying parts that could cause personal injury.

2. Relax compression on spring (8) by turning the knob (3) CCW until removed from spring chamber (2). Not necessary to rotate nut (5). Remove name plate.
3. Loosen spring chamber by placing wrench on flats of spring chamber and rotating CCW making sure not to use flats on side with vent hole.
4. Remove spring chamber, (2) ball (6), spring button (7), range spring (8) and spacer (19).
5. Remove the diaphragm sub-assembly. See Figure 1.
6. Secure the O.D. of the pressure plate in soft jawed vise. With a wrench, secure the flats on the plug (10). With another wrench, rotate the hex nut (11) CCW and remove nut and lock washer (12). **NOTE:** Plug (10), travel stop (15), diaphragm (16), pusher plate (17)

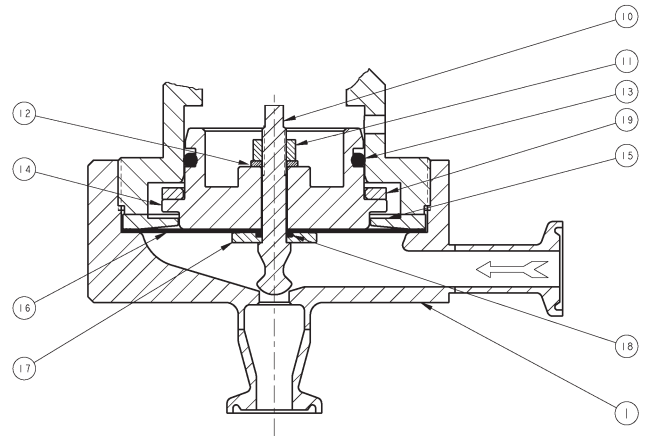

FIGURE 1: Diaphragm & Plug Subassembly

and o-ring (18) may slide out of the pressure plate (14). Do not let parts fall and damage seat surface on the plug.

7. Remove travel stop, diaphragm, o-ring and pusher plate from plug. Remove stabilizing o-ring (13) from groove in O.D. of pressure plate.
8. Inspect inside surface of body (1). If seating area shows signs of erosion/wear replace with a new regulator.
9. For Model BL1: orient the body in a soft-jaw vise with the body cap (9) upwards. Rotate body cap CCW to remove. Remove o-ring (21).
10. Clean body cavity and all reusable parts. **NOTE:** Maintenance must include a level of cleanliness equal to Cashco cleaning standard #S-1576. Contact factory for details.
11. For Model BL1: secure the body (1) in a soft-jaw vise using the flats on the body. Orient the body with smaller, threaded I.D. facing upwards. Place the o-ring (21) onto the landing above the threads. Lightly apply "Food Grade Anti-Seez" to the body cap (9) threads and install into the body. Tighten to 25-30 ft.-lbs.
12. Orient the body in a soft jaw vise to where the larger, threaded I.D. faces upward. Place the seat end of the plug (10) into the body.
13. Place the pusher plate (17) over the threaded end of the plug. Be sure to correctly orient the pusher plate so the o-ring groove faces up.

14. Place o-ring (18), diaphragm (16), travel stop (15) and pressure plate (14) over threaded end of the plug. Ensure that the grooved side of the travel stop faces the diaphragm.
15. Place the lock washer (12) and nut (11) over threaded end of plug, rotate CW hand tight. Using a small adjustable wrench, hold the plug in place by the flats at the top. Use a 7/16" wrench to tighten the nut to approx. 50 in. -lbs.
16. Lubricate o-ring (13) with "Food Grade Anti-Seez" and place it over the pressure plate (14) into the groove. Slide spacer (19) down around pressure plate, resting on shoulder.
17. Position the range spring (8) onto the pressure plate. Set spring button (7) and ball (6) on top of spring. Apply a small amount of "Food Grade Anti-Seez" to the ball.
18. Lubricate the outside threads and the flat bottom surface of the spring chamber (2) and the threads of the adjusting screw (4) with "Food Grade Anti-Seez".
19. Thread the spring chamber into the body and tighten to 75-100 ft.-lbs.
20. Place the nameplate below the jam nut (5) and thread adjusting screw into the spring chamber until nut (5) makes contact with top of spring chamber.
21. Use the appropriate end connections and test per Cascho Spec #S-1526 for Back Pressure Regulators.
22. Return to Section IV for start up.

NOTES

SECTION VII

VII. TROUBLE SHOOTING GUIDE

1. Erratic operation; chattering.

| Possible Cause | Remedy |
|-------------------------------------|---|
| A. Oversized regulator. | A1. Check actual flow conditions, re-size regulator for minimum and maximum flow. A2. Increase flow rate. A3. Decrease regulator pressure drop; decrease inlet pressure by placing a throttling orifice in inlet piping union. A4. Install next step higher range spring. Contact factory. A5. Before replacing regulator, contact factory. |
| B. Worn O-ring; inadequate guiding. | B. Replace stabilizing o-ring (13). |

2. Regulator inlet (upstream) too high:

| Possible Cause | Remedy |
|---|--|
| A. Regulator undersized. | A1. Confirm by opening bypass valve together with regulator. A2. Check actual flow conditions, re-size regulator; if regulator has inadequate capacity, replace with larger unit. |
| B. Incorrect range spring (screwing out CCW of adjusting screw does not allow bringing pressure level to proper level). | B. Replace range spring with proper lower range. Contact factory. |
| C. Too much rise (build). | C1. Review rise (build) expected. C2. Contact factory. |

3. Leakage through the spring chamber vent hole.

| Possible Cause | Remedy |
|---|---|
| A. Normal-life diaphragm failure. | A. Replace diaphragm. |
| B. Abnormal short-life diaphragm failure. | B1. Can be caused by excessive chattering. See No. 1. to remedy chatter. B2. Can be caused by corrosive action. Consider alternate diaphragm material. B3. Composition diaphragm, ensure not subjecting to over-temperature conditions. B4. Upstream (inlet) pressure build-up occurring that overstresses diaphragms. Relocate regulator or protect with safety relief valve. |
| C. O-ring failure. | C. Replace O-ring (18). |

4. Sluggish operation.

| Possible Cause | Remedy |
|---------------------------------|---------------------------------|
| A. Plugged spring chamber vent. | A. Clean vent opening. |
| B. Fluid too viscous. | B. Heat fluid. Contact factory. |

SECTION VIII

VIII. ORDERING INFORMATION NEW REPLACEMENT UNIT vs PARTS "KIT" FOR FIELD REPAIR

To obtain a quotation or place an order, please retrieve the Serial Number and Product Code that was stamped on the metal name plate and attached to the unit. This information can also be found on the Bill of Material ("BOM"), a parts list that was provided when unit was originally shipped. (Serial Number typically 6 digits). Product Code typical format as follows: (last digit is alpha character that reflects revision level for the product).

□□□□ - □□□□ 7 - □□□□□□□□□□

NEW REPLACEMENT UNIT:

Contact your local Cashco, Inc., Sales Representative with the Serial Number and Product code. With this information they can provide a quotation for a new unit including a complete description, price and availability.



CAUTION

Do not attempt to alter the original construction of any unit without assistance and approval from the factory. All purposed changes will require a new name plate with appropriate ratings and new product code to accommodate the recommended part(s) changes.

PARTS "KIT" for FIELD REPAIR:

Contact your local Cashco, Inc., Sales Representative with the Serial Number and Product code. Identify the parts and the quantity required to repair the unit from the "BOM" sheet that was provided when unit was originally shipped.

NOTE: *Those part numbers that have a quantity indicated under "Spare Parts" in column "A" reflect minimum parts required for inspection and rebuild, - "Soft Goods Kit". Those in column "B" include minimum trim replacement parts needed plus those "Soft Goods" parts from column "A".*

If the "BOM" is not available, refer to the cross-sectional drawings included in this manual for part identification and selection.

A Local Sales Representative will provide quotation for appropriate Kit Number, Price and Availability.

The contents of this publication are presented for informational purposes only, and while every effort has been made to ensure their accuracy, they are not to be construed as warranties or guarantees, express or implied, regarding the products or services described herein or their use or applicability. We reserve the right to modify or improve the designs or specifications of such product at any time without notice. Cashco, Inc. does not assume responsibility for the selection, use or maintenance of any product. Responsibility for proper selection, use and maintenance of any Cashco, Inc. product remains solely with the purchaser.

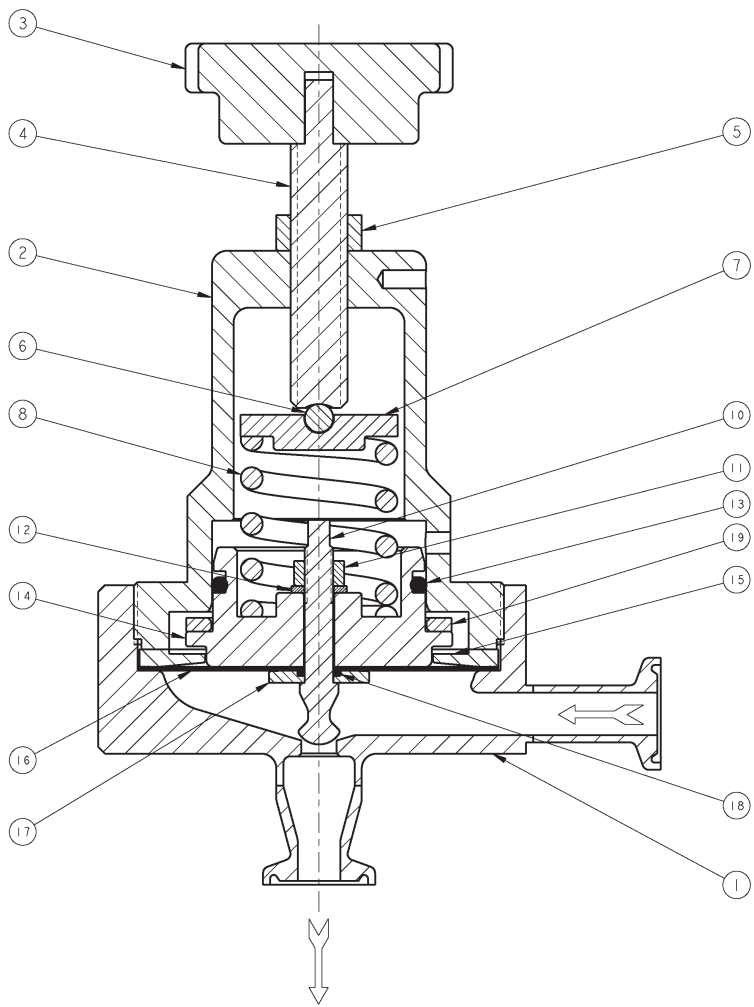
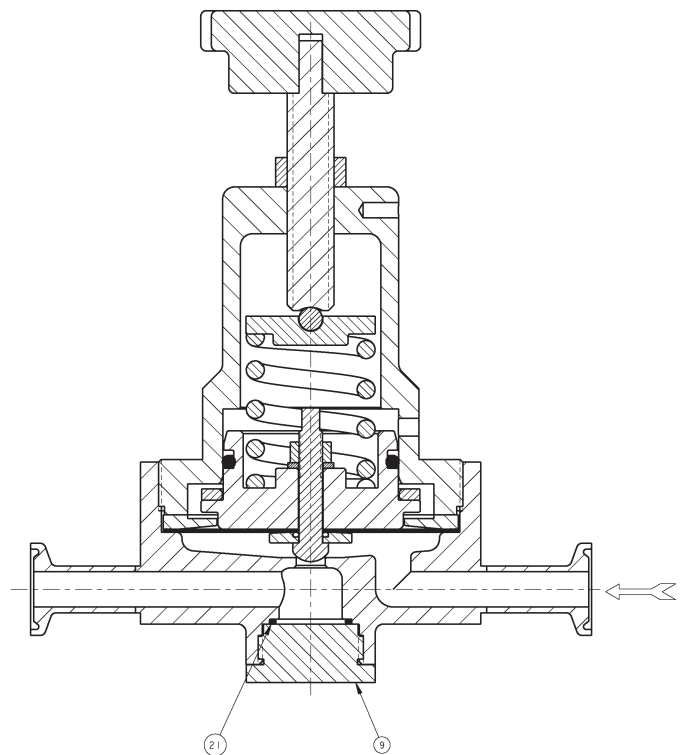

FIGURE 2
Model BA1-BL1 Metal Seat

| Item No. | Description |
|-----------------|---|
| 1 | Body |
| 2 | Spring Chamber |
| 3 | Knob |
| 4 | Adjusting Screw |
| 5 | Jam Nut |
| 6 | Ball |
| 7 | Spring Button |
| 8 | Range Spring |
| 9 | Body Cap (Inline Style Only) |
| 10 | Plug |
| 11 | Hex Nut (Plug) |
| 12 | * Lock Washer (Plug) |
| 13 | * Stabilizing O-Ring |
| 14 | Pressure Plate |
| 15 | Travel Stop |
| 16 | * Diaphragm |
| 17 | * Pusher Plate |
| 18 | * O-Ring (Pusher Plate) |
| 19 | Spacer |
| 20 | Nameplate (Not Shown) |
| 21 | * O-Ring (Body Cap) (Inline Style Only) |

* Recommended replacement part



ATEX 2014/34/EU: Explosive Atmospheres and Cashco Inc. Products



Cashco, Inc. declares that the products listed in the table below has been found to comply with the Essential Health and Safety Requirements relating to the design and construction of products intended for use in potentially explosive atmospheres given in Annex II of the ATEX Directive 2014/34/EU. Compliance with the Essential Health and Safety Requirements has been assured by compliance with EN ISO 80079-36:2016 and EN ISO 80079-37:2016. The product will be marked as follows:

CE Ex II 2 G
Ex h IIB T6... T1 Gb
1000ATEXR1 X

The 'X' placed after the technical file number indicates that the product is subject to specific conditions of use as follows:

1. The maximum surface temperature depends entirely on the operating conditions and not the equipment itself. The combination of the maximum ambient and the maximum process medium temperature shall be used to determine the maximum surface temperature and corresponding temperature classification, considering the safety margins described prescribed in EN ISO 80079-36:2016, Clause 8.2. Additionally, the system designer and users must take precautions to prevent rapid system pressurization which may raise the surface temperature of system components and tubing due to adiabatic compression of the system gas. Furthermore, the Joule-Thomson effect may cause process gases to rise in temperature as they expand going through a regulator. This could raise the external surface temperature of the regulator body and the downstream piping creating a potential source of ignition. Whether the Joule-Thomson effect leads to heating or cooling of the process gas depends on the process gas and the inlet and outlet pressures. The system designer is responsible for determining whether the process gas temperature may raise under any operating conditions.
2. Where the process medium is a liquid or semi-solid material with a surface resistance in excess of $1G\Omega$, special precautions shall be taken to ensure the process does not generate electrostatic discharge.
3. Special consideration shall be made regarding the filtration of the process medium if there is a potential for the process medium to contain solid particles. Where particles are present, the process flow shall be $<1\text{m/s}$ ($<3.3\text{ ft/s}$) in order to prevent friction between the process medium and internal surfaces.
4. Effective earthing (grounding) of the product shall be ensured during installation.
5. The valve body/housing shall be regularly cleaned to prevent build up of dust deposits.
6. Regulators must be ordered with the non-relieving option (instead of the self-relieving option) if the process gas they are to be used with is hazardous (flammable, toxic, etc.). The self-relieving option vents process gas through the regulator cap directly into the atmosphere while the non-relieving option does not. Using regulators with the self-relieving option in a flammable gas system could create an explosive atmosphere in the vicinity of the regulator.
7. Tied diaphragm regulators with outlet ranges greater than 7 barg (100 psig) should be preset to minimize the risk that improper operation might lead to an outboard leak and a potentially explosive atmosphere.
8. All equipment must only be fitted with manufacturer's original spare parts.
9. Ensure that only non-sparking tools are used, as per EN 1127-1, Annex A.

| | PRODUCT |
|------------------------|--|
| REGULATORS | 31-B, 31-N |
| | 1164, 1164(OPT-45) |
| | 1171, 1171(OPT-45), 1171(CRYO) |
| | 2171, 2171(OPT-45), 2171(CRYO), 3171 |
| | 1465, 3381, 3381(OPT-45), 3381(OPT-40) |
| | 4381, 4381(OPT-37), 4381(CRYO), 4381(OPT-45), 5381 |
| | MPRV-H, MPRV-L |
| | PBE, PBE-L, PBE-H |
| | CA-1, CA-2 |
| | CA1, SA1, CA4, SA4, CA5, SA5 |
| | DA2, DA4, DA5, DA6, DA8 |
| | DA0, DA1, DAP, SAP |
| | SLR-1, SLR-2, PTR-1 |
| | ALR-1, ULR-1, PGR-1 |
| | BQ, BQ(OPT-45), BQ(CRYO) |
| | 123, 123(CRYO), 123(OPT-45), 123(OPT-46G) |
| | 123-1+6, 123-1+6(OPT-45), 123-1+6(OPT-46G), 123-1+6+S, 123-1+6+S(OPT-40) |
| | 1000HP, 1000HP(OPT-37), 1000HP(OPT-45), 1000HP(OPT-45G), 1000HP(CRYO) |
| | 1000HP-1+6, 1000HP-1+8, 1000LP, 1000LP(OPT-45), 1000LP(OPT-46G) |
| | 6987 |
| | 8310HP, 8310HP-1+6, 8310HP-1+8, 8310LP, 8311HP, 8311LP |
| | 345, 345(OPT-45) |
| | BA1/BL1, PA1/PL1 |
| | C-BPV, C-PRV, C-CS |
| | D, D(CRYO), D(OPT-37), D(OPT-20), D(OPT-45) |
| | DL, DL(LCC), DL(OPT-45) |
| | BR, BR(CRYO) |
| | HP, HP(LCC), HP(OPT-45), HP(OPT46G), HP-1+6+S(OPT-40), HP-1+6+S |
| | P1, P2, P3, P4, P5, P7 |
| | B2, B7 |
| | POSR-1, POSR-2 |
| | 5200P, 5300P |
| | 135 |
| | NW-PL, NW-SO |
| CG-PILOT | |
| FG1 | |
| CONTROL VALVES | RANGER, 987, PREMIER |
| | 964, 521, 988, 988-MB, 989 |
| | 2296/2296HF |
| | SCV-30, SCV-S |
| | FL800/FL200 |
| TANK BLANKETING | 8700, 8910, 8920, 8930, 8940 |
| | 2100, 2199 |
| | 3100, 3200, 3300, 3400, 3500, 3600, 3700 |
| | 1078, 1088, 1100, 1049 |
| | 5100, 5200, 5400, 5500 |
| | 4100, 4200, 4300, 4400, 4500, 4600 |
| MISC | 764P/PD, 764-37, 764T |

Cashco, Inc.
P.O. Box 6
Ellsworth, KS 67439-0006
PH (785) 472-4461
Fax. # (785) 472-3539
www.cashco.com
email: sales@cashco.com

Cashco GmbH
Handwerkerstrasse 15
15366 Hoppegarten, Germany
PH +49 3342 30968 0
Fax. No. +49 3342 30968 29
www.cashco.com
email: germany@cashco.com

Cashco do Brasil, Ltda.
Al.Venus, 340
Indaiatuba - Sao Paulo, Brazil
PH +55 11 99677 7177
Fax. No.
www.cashco.com
email: brazil@cashco.com