

Type 8696 REV.2

Positioner Top Control Basic

Electropneumatic Position Controller



Operating Instructions

We reserve the right to make technical changes without notice.
Technische Änderungen vorbehalten.
Sous réserve de modifications techniques.

© Bürkert Werke GmbH & Co. KG, 2019 - 2023

Operating Instructions 2302/02_EN-EN_00805905 / Original DE

Positioner Type 8696 REV.2

TABLE OF CONTENTS

1	ABOUT THESE INSTRUCTIONS	7
1.1	Symbols.....	7
1.2	Definition of terms.....	7
2	INTENDED USE	8
3	BASIC SAFETY INSTRUCTIONS	9
4	GENERAL INFORMATION	10
4.1	Contact address.....	10
4.2	Warranty	10
4.3	Trademarks.....	10
4.4	Information on the internet	10
5	SYSTEM DESCRIPTION	11
5.1	Designated application area.....	11
5.2	Function of the positioner and combination with valve types	11
5.3	Features of the valve types.....	12
5.4	Model for control of third-party devices	13
5.5	Structure of the positioner.....	14
5.5.1	Representation	14
5.5.2	Features	15
5.5.3	Functional diagram of the positioner with single-acting actuator.....	16
5.6	Type 8696 positioner.....	17
5.6.1	Schematic representation of the position control Type 8696	17
5.6.2	Functions of the positioner software	18
5.7	Interfaces of the positioner	20
6	TECHNICAL DATA	21
6.1	Standards and guidelines	21
6.2	Licenses	21
6.3	Operating conditions	21

MAN 1000417068 EN Version: B Status: RL (released | freigegeben) printed: 24.04.2026

6.4	Mechanical data.....	22
6.5	Pneumatic data	22
6.6	Type label	22
6.7	UL additional label	23
6.8	Electrical data	23
6.8.1	Electrical data, without fieldbus communication.....	23
6.8.2	Electrical data, IO-Link	24
6.8.3	Electrical data, bÜS.....	24
6.9	Factory settings of the positioner	25
7	CONTROL AND DISPLAY ELEMENTS	26
7.1	Operating state	26
7.2	Control and display elements of the positioner.....	27
7.3	Configuration of the buttons.....	28
7.4	Display of the LEDs.....	30
7.4.1	Cutoff LED	30
7.4.2	Manual LED	30
7.4.3	Charact LED.....	30
7.4.4	Status indicator.....	31
7.5	Error messages.....	33
7.5.1	Messages for device status “Out of specification“	33
7.5.2	Messages: Actuator moves to safety position	33
8	INSTALLATION.....	35
8.1	Safety instructions	35
8.2	Installation of the positioner Type 8696 to process valves of series 2103, 2300 and 2301....	35
8.3	Rotating the actuator module for process valves belonging to series 2300 and 2301	39
9	PNEUMATIC INSTALLATION.....	41
10	ELECTRICAL INSTALLATION.....	43
10.2	Electrical installation without fieldbus communication.....	44
10.3	Electrical installation, IO-Link.....	46
10.4	Electrical Installation, bÜS	46

11	START-UP	47
11.1	Safety instructions	47
11.2	Specifying the standard settings	47
11.2.1	Running the automatic adjustment X.TUNE	47
11.3	Setting with Bürkert Communicator.....	49
11.3.1	Connecting IO-Link device with Bürkert Communicator.....	49
11.3.2	Connecting büS device with Bürkert Communicator	50
12	IO-LINK.....	51
12.1	Information, IO-Link	51
12.2	Technical specifications, IO-Link	51
12.2.1	Configuration of the fieldbus	51
13	BÜS.....	52
13.1	Information, büS.....	52
13.2	Configuration of the fieldbus	52
14	OPERATION AND FUNCTION.....	53
14.1	Basic functions.....	53
14.1.1	DIR.CMD - Reversal of the effective direction of the positioner set-point value	55
14.1.2	CUTOFF - Sealing function for the positioner.....	56
14.1.3	CHARACT - Characteristic correction between input signal (position set-point value) and stroke.....	57
14.1.4	INPUT - Enter the standard signal (only variant without fieldbus communication)	59
14.1.5	RESET - Reset to factory settings.....	60
14.1.6	X.TUNE - Automatic adjustment of the positioner to the relevant operating conditions.....	60
14.2	Auxiliary functions	61
14.2.1	DIR.ACT - Reversal of the effective direction of the actuator.....	62
14.2.2	SPLTRNG - Signal split range	63
14.2.3	X.LIMIT - Stroke limit.....	64
14.2.4	X.TIME - Limit actuating time	65

14.2.5	X.CONTROL - Control parameters of the positioner.....	66
14.2.6	SAFPOS - Definition of the safe position.....	66
14.2.7	SIG.ERROR - Configuration of cable break detection (only for variant without fieldbus communication).....	67
14.2.8	BINARY.IN (variant) - Configuration of the digital input (only for variant without fieldbus communication) .	67
14.2.9	OUTPUT (variant) - Configuration of the analog output (only for variant without fieldbus communication).....	68
14.2.10	Setting the LED mode, device status.....	68
15	SAFETY END POSITIONS	69
15.1	Safety end positions after failure of the electrical or pneumatic auxiliary power.....	69
16	MAINTENANCE	69
17	DISASSEMBLY	70
17.1	Safety instructions.....	70
17.2	Disassembly the positioner.....	70
18	ACCESSORIES	72
18.1	Communications software.....	72
19	TRANSPORTATION, STORAGE, DISPOSAL	73

1 ABOUT THESE INSTRUCTIONS

The operating instructions describe the entire life cycle of the device.

→ Keep these instructions ready to hand at the operation site.

Important safety information.

- ▶ Carefully read these instructions.
- ▶ Observe in particular the safety instructions, intended use and operating conditions.
- ▶ Persons, who work on the device, must read and understand these instructions.

1.1 Symbols

DANGER

Warns of an immediate danger.

- ▶ Failure to observe the warning will result in a fatal or serious injury.

WARNING

Warns of a potentially dangerous situation.

- ▶ Failure to observe the warning may result a fatal or serious injury.

CAUTION

Warns of a possible danger.

- ▶ Failure to observe the warning may result in moderate or minor injuries.

ATTENTION

Warns of damage to property.

- ▶ Failure to observe the warning may result in damage to device or system.

 Indicates important additional information, tips and recommendations.

 Refers to information in these operating instructions or in other documentation.

▶ Indicates an instruction for risk prevention.

→ Indicates a procedure which you must carry out.

 Indicates a result.

Menu Indicates a interface text.

1.2 Definition of terms

In these instructions the term “device” denotes the following device types:

Positioner Type 8696 REV.2

The term “bÜS” (Bürkert system bus) used in this instruction stands for the communication bus developed by Bürkert and based on the CANopen protocol.

In these instructions, the abbreviation “Ex” always refers to “potentially explosive atmosphere”.

2 INTENDED USE

The Positoner Type 8696 REV.2 is designed to be mounted on pneumatic actuators of process valves for the control of media. The permitted fluid media are listed in the technical data.

- ▶ Use the device for its intended purpose only. Non-intended use of the device may be dangerous to people, nearby equipment and the environment.
- ▶ Correct transportation, correct storage as well as correct installation, commissioning, operation and maintenance are essential for reliable and problem-free operation.
- ▶ When using the device, observe the permitted data, operating conditions and application conditions. This information can be found in the contractual documents, the operating instructions and on the type label.
- ▶ Use the device only in conjunction with third-party devices and components recommended and authorized by Bürkert.
- ▶ Do not use the device outdoors without protection from the weather.
- ▶ In potentially explosive atmosphere, only use devices approved for use in those areas. These devices are labeled with a separate Ex type label. For such use, note the information provided on the separate Ex type label and the additional explosion-related information or separate explosion-related operating instructions.

3 BASIC SAFETY INSTRUCTIONS

These safety instructions do not consider any contingencies or incidents which occur during installation, operation and maintenance.

The operator is responsible for observing the location-specific safety regulations, also with reference to the personnel.

DANGER

Risk of injury from high pressure and discharge of medium.

- ▶ Before working on the device or system, switch off the pressure. Vent or drain lines.

DANGER

Risk of injury from electric shock.

- ▶ Before working on the device or system, switch off the power supply. Secure against reactivation.
- ▶ Observe applicable accident prevention and safety regulations for electrical equipment.



To prevent injury, ensure the following:

- ▶ Secure device or system to prevent unintentional activation.
- ▶ Only trained technicians may perform installation and maintenance work.
- ▶ Perform installation and maintenance with suitable tools only.
- ▶ Do not make any changes to the device and do not subject it to mechanical stress.
- ▶ Operate the device only in perfect state and in consideration of the operating instructions.
- ▶ Observe the general rules of technology.
- ▶ Install the device according to the regulations applicable in the respective country.
- ▶ Do not feed corrosive or flammable media into the device connections.
- ▶ Do not feed any fluids into the connections of the device.
- ▶ After the process is interrupted, restart in a controlled manner. Observe sequence:
 1. Connect electrical or pneumatic power supply.
 2. Charge the device with medium.
- ▶ Observe intended use.

ATTENTION!

Electrostatic sensitive components or modules.

The device contains electronic components, which react sensitively to electrostatic discharge (ESD). Contact with electrostatically charged persons or objects is hazardous to these components. In the worst case scenario, they will be destroyed immediately or will fail after start-up.

- ▶ Observe the requirements in accordance with EN 61340-5-1 and to minimize or avoid the possibility of damage caused by sudden electrostatic discharge.
- ▶ Also ensure that you do not touch electronic components when the power supply is on.

4 GENERAL INFORMATION

4.1 Contact address

Germany

Bürkert Fluid Control System
Sales Centre
Chr.-Bürkert-Str. 13-17
D-74653 Ingelfingen
Tel. + 49 (0) 7940 - 10 91 111
Fax + 49 (0) 7940 - 10 91 448
E-mail: info@burkert.com

International

Contact addresses can be found on the final pages of the printed operating instructions.

And also on the internet at:

country.burkert.com

4.2 Warranty

The warranty is only valid if the positioner Type 8696 is used as intended in accordance with the specified application conditions.

4.3 Trademarks

Brands and trademarks listed below are trademarks of the corresponding companies / associations / organizations

Loctite Henkel Loctite Deutschland GmbH

4.4 Information on the internet

The operating instructions and data sheets for Type 8696 can be found on the Internet at:

country.burkert.com

5 SYSTEM DESCRIPTION

5.1 Designated application area

The positioner Type 8696 is designed to be mounted on pneumatic actuators of process valves for the control of media.

5.2 Function of the positioner and combination with valve types

Positioner Type 8696 is an electropneumatic position controller for pneumatically actuated control valves with single-acting actuators.

Together with the pneumatic actuator, the positioner forms a functional unit.

The control valve systems can be used for a wide range of control tasks in fluid technology and, depending on the application conditions, different process valves from the Bürkert range can be combined with the positioner. Angle seat valves, straight seat valves or diaphragm valves of the Type 2300, 2301 or 2103 with an actuator size of 50 mm are suitable.

“Figure 1” shows an overview of the possible combinations of positioner and different pneumatically actuated valves. Different valve orifices, not illustrated here, are available for each type. More precise specifications can be found on the respective data sheets. The product range is being continuously expanded.

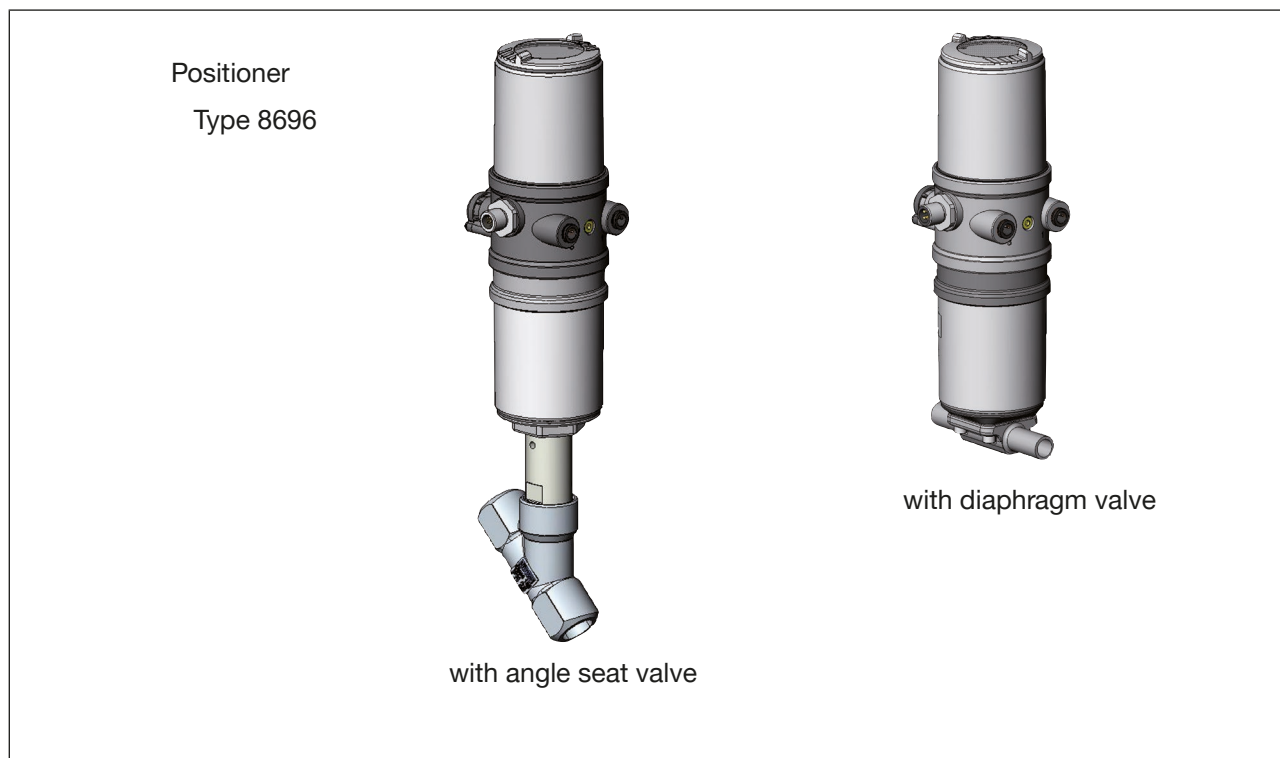

Figure 1: Overview of possible combinations

The position of the actuator is regulated according to the position set-point value. The nominal position value is specified by an external standard signal.

Pneumatically actuated piston actuators and rotary actuators can be used as an actuator. Single-acting actuators are offered in combination with the positioner.

For single-acting actuators, only one chamber is aerated and deaerated during actuation. The generated pressure works against a spring. The piston moves until there is an equilibrium of forces between compressive force and spring force.

5.3 Features of the valve types

	Angle seat control valves / Straight seat control valves	Diaphragm Valves
Types	<ul style="list-style-type: none"> • 2300 • 2301 	<ul style="list-style-type: none"> • 2103
Features	<ul style="list-style-type: none"> • incoming flow under seat • no pressure surges when closing the valve • straight flow path of the medium • self-adjusting packing gland for high leak-tightness 	<ul style="list-style-type: none"> • medium is hermetically separated from the actuator and environment • cavity-free and self-draining body design • any flow direction with low-turbulence flow • steam-sterilizable • CIP-compliant • no pressure surges when closing the valve • actuator and diaphragm can be removed when the housing is installed
Typical media	<ul style="list-style-type: none"> • water, steam and gases • alcohols, oils, propellants, hydraulic fluids • salt solutions, lyes (organic) • solvents 	<ul style="list-style-type: none"> • neutral gases and liquids • contaminated, abrasive and aggressive media • media of higher viscosity

Table 1: Features of the valve types

5.4 Model for control of third-party devices

A special model enables the positioner Type 8696 to be attached to third-party devices.

This model has a different basic housing so that the pilot air ports can be connected to the outside of the actuator.

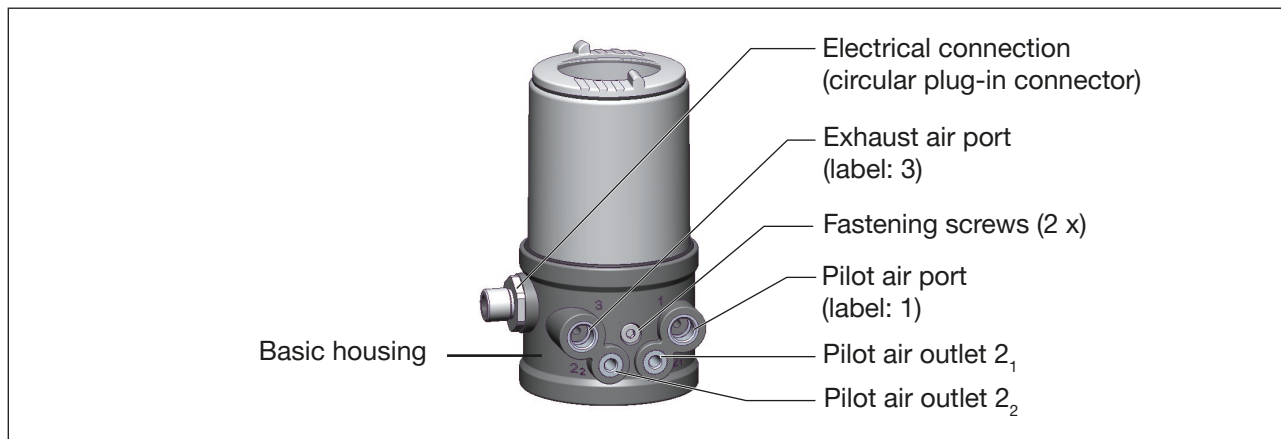

Figure 2: Model for third-party devices

ATTENTION!

Damage or malfunction due to ingress of dirt and moisture.

- ▶ To comply with degree of protection IP65 / IP67, connect the pilot air outlet (only for CFA or CFB) which is not required to the free pilot air port of the third-party device or seal with a plug.



“In rest position” means that the pilot valves of the positioner Type 8696 are isolated or not actuated.



If the ambient air is humid, a hose can be connected between pilot air outlet 2_2 of the positioner and the unconnected pilot air port of the third-party device for control function A or control function B. As a result, the spring chamber of the third-party device is supplied with dry air from the vent duct of the positioner.

Control function (CF)		Pneumatic connection Type 8696 with third-party device
A	Process valve closed in rest position (by spring force)	Pilot air outlet $2_2^{1)}$ → 
B	Process valve open in rest position (by spring force)	Pilot air outlet 2_1 → 

Table 2: Pneumatic connection to third-party device

1) Connection optionally, see note.

5.5 Structure of the positioner

The positioner Type 8696 consists of the micro-processor controlled electronics, the position sensor and the pilot valve system.

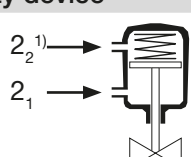
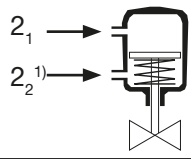
The operation of the positioner takes place via 2 buttons and Bürkert Communicator.

The pilot valve system for single-acting actuators consists of two solenoid valves.

5.5.1 Representation

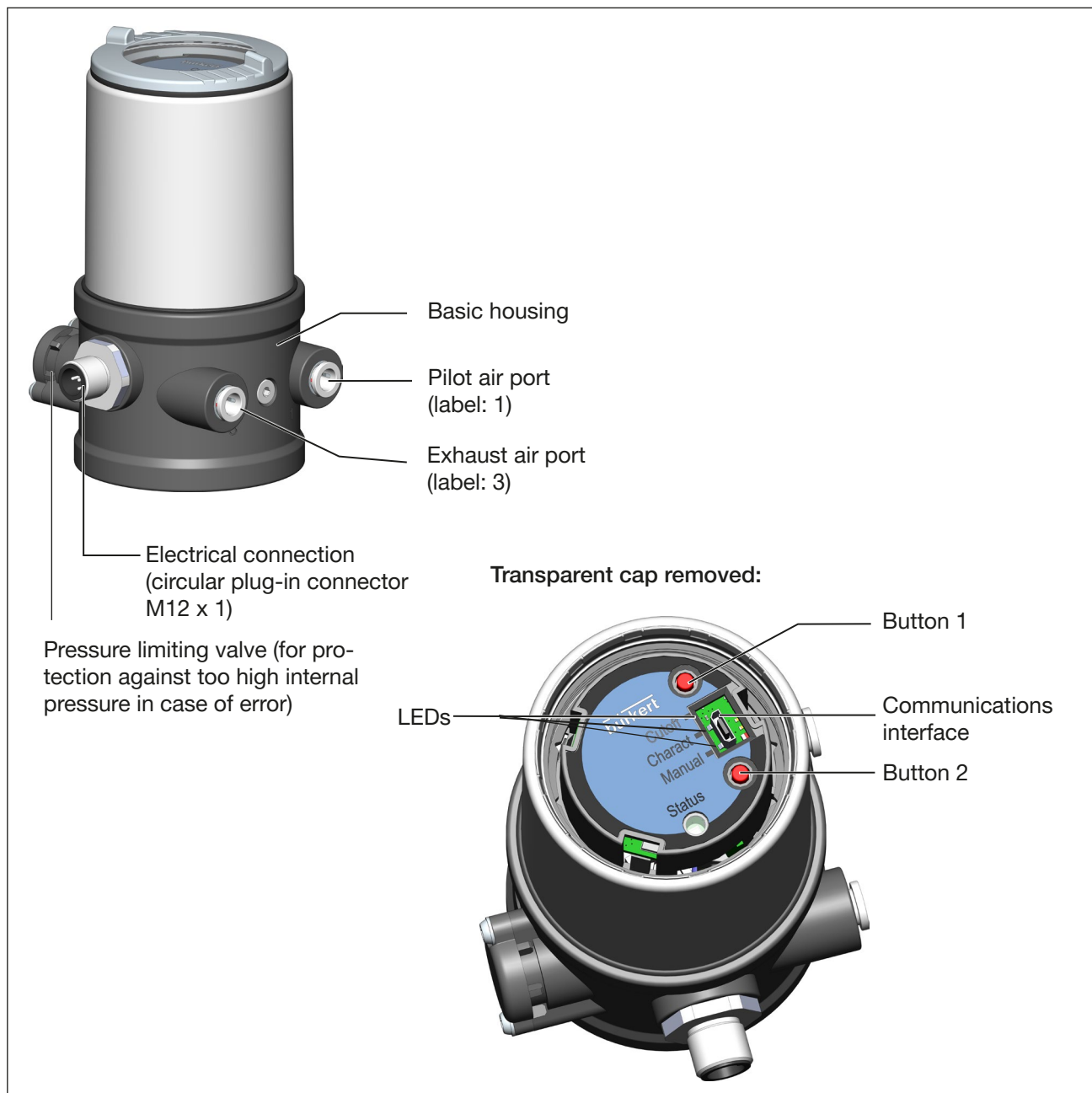
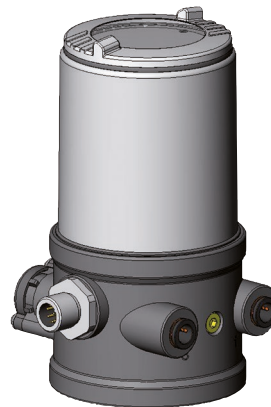

Figure 3: Structure

5.5.2 Features

- **Models**
for single-acting valve actuators.
- **Position sensor**
Contactless and therefore non-wearing position sensor.
- **Microprocessor-controlled electronics**
for signal processing, control and valve control.
- **Control module**
The operation of the device takes place via 2 buttons and Bürkert Communicator.
- **Pilot valve system**
The control system consists of 2 solenoid valves. One valve is used to aerate and another to deaerate the pneumatic actuator. The solenoid valves operate according to the rocker principle and are controlled with a PWM voltage via the controller. Doing so achieves a higher flexibility with regard to actuator volume and final control speed. The direct-action model has an orifice of DN 0.6.
- **Position feedback**
The position of the valve can be transmitted to the PLC via an analog 0/4-20 mA output (variant, without fieldbus communication) or digitally via a fieldbus communication (e.g. bÜS, IO-Link).
- **Digital input (for variant without fieldbus communication)**
If a voltage > 10 V is applied, safety position (*SAFEPOS*) is activated, i.e. the valve is moved to the safety position (factory setting, can be changed with communications software).
- **Pneumatic interfaces**
hose plug-in connection \varnothing 6 mm / 1/4"
on request: threaded port
- **Electrical interfaces**
Circular plug-in connection
- **Housing**
The housing of the positioner is protected from excessively high internal pressure, e.g. due to leaks, by a pressure limiting valve.
- **Communications interface**
For exchanging process data and for configuration and parameterization.



5.5.3 Functional diagram of the positioner with single-acting actuator

The displayed functional diagram describes the function of the positioner (Type 8696).

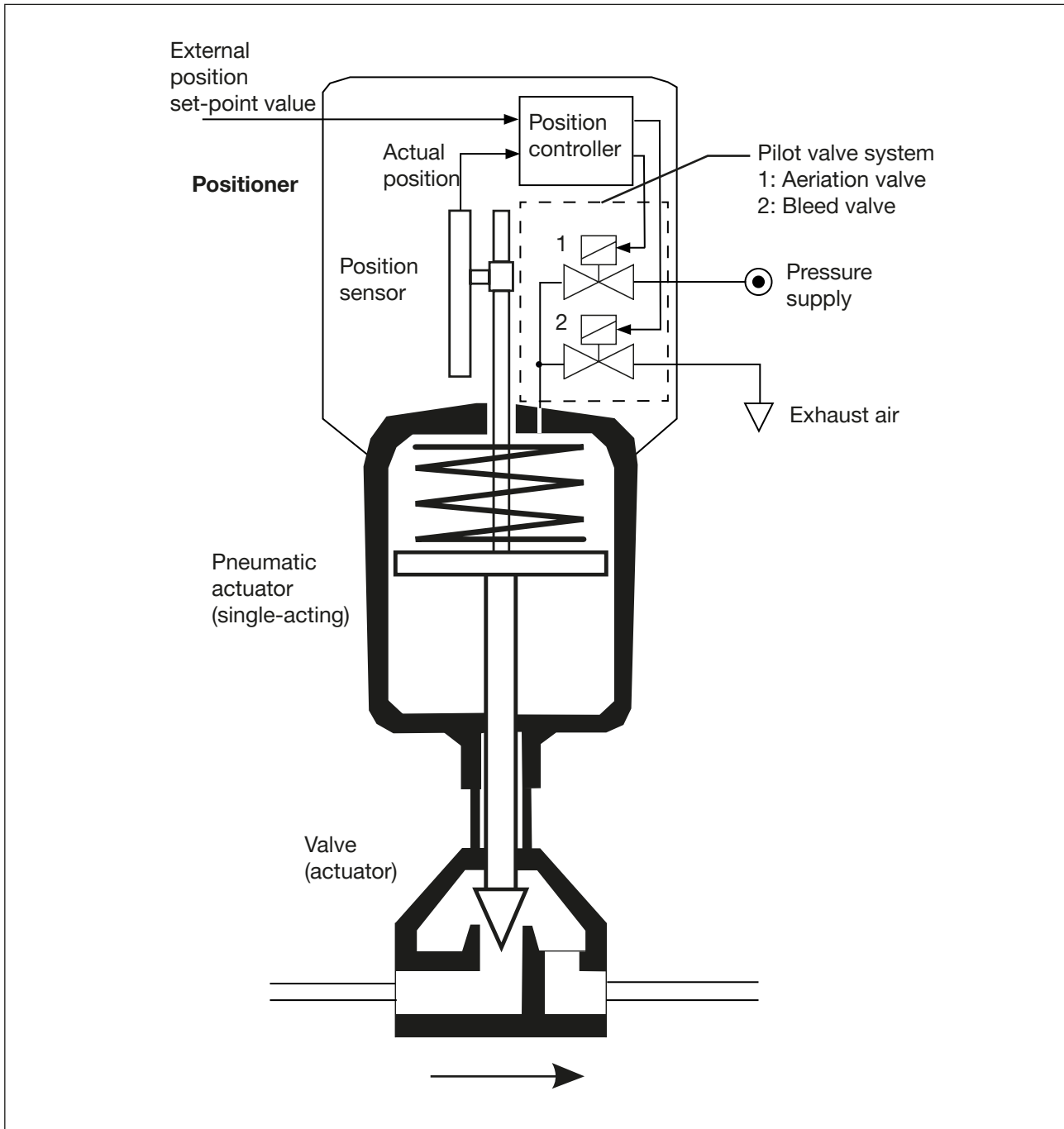

Figure 4: Function diagram

5.6 Type 8696 positioner

The position sensor records the current position (*POS*) of the pneumatic actuator. The positioner compares this actual position value with the set-point value (*CMD*). In case of a control deviation (*Xd1*), a pulse-width modulated voltage signal is sent to the pilot valve system as a manipulated variable. If there is a positive control difference in single-acting actuators, the air inlet valve is controlled via output B1. If the control difference is negative, the bleed valve is controlled via output E1. In this way the position of the actuator is changed until control difference is 0. *Z1* represents a disturbance variable.

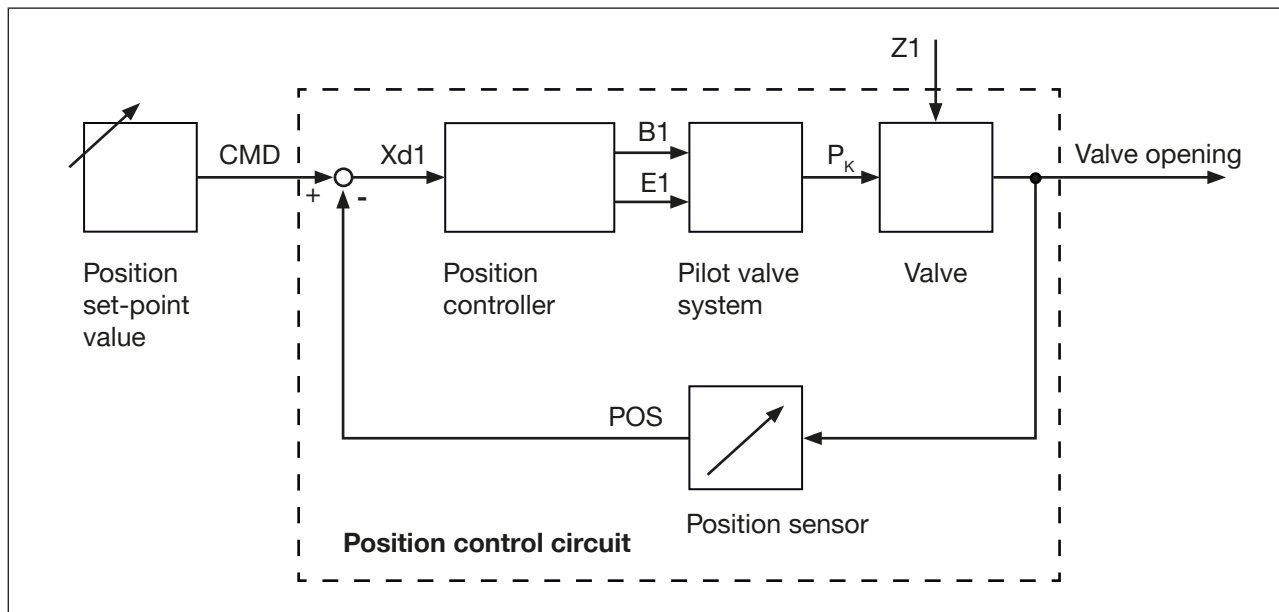

Figure 5: Signal flow plan of positioner

5.6.1 Schematic representation of the position control Type 8696

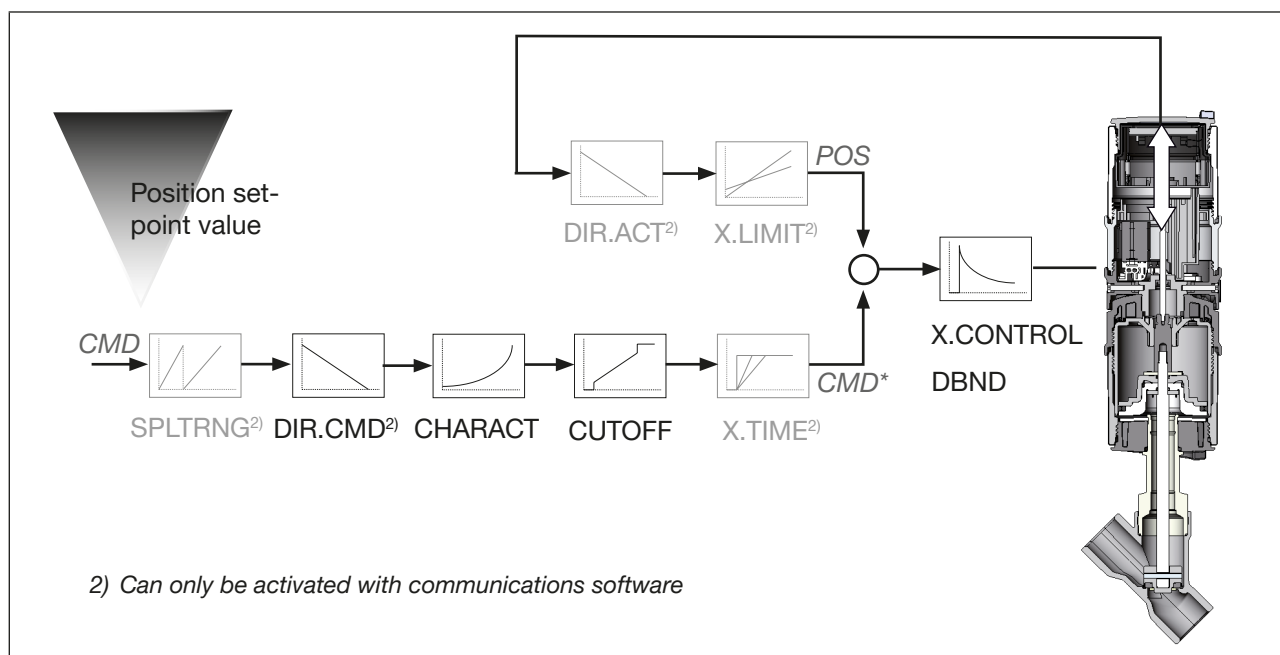

Figure 6: Schematic representation of the position control

5.6.2 Functions of the positioner software

Basic functions

- Activation with buttons
- Parameter setting with communications software

Function	Effect
Sealing function <i>CUTOFF</i>	Valve closes tight outside the control range. Specification of the value (as %), from which the actuator is completely deaerated (when 0 %) or aerated (when 100 %)
Characteristic correction <i>CHARACT</i>	Linearization of the operating characteristic can be implemented

Table 3: Basic functions

Basic functions

- Activation with buttons or communications software

Function	Effect
Standard signal ³⁾⁴⁾ <i>INPUT</i>	Select set-point value standard signal
Reversal of the effective direction set-point value ³⁾ <i>DIR.CMD</i>	Reversal of the effective direction of the set-point value
Automatic calibration of the position controller <i>X.TUNE</i>	
Reset to factory settings <i>RESET</i>	Reset to factory settings

Table 4: Basic functions

3) Only adjustable with communications software.

4) Only for variant without fieldbus communication.

Auxiliary functions

- Activation and parameter setting with communications software

Function	Effect
Reversal of the effective direction of the actuator <i>DIR.ACT</i>	Assignment of the aeration status of the actuator chamber to the actual position.
Signal split range <i>SPLTRNG</i>	Standard signal as % for which the valve runs through the entire mechanical stroke range.
Stroke limit <i>X.LIMIT</i>	Limit the mechanical stroke range
Limit actuating time <i>X.TIME</i>	Limit the control speed
Control parameters <i>X.CONTROL</i>	Parameterize the position controller
Safety position <i>SAFEPOS</i>	Definition of the safety position
Cable break detection ⁵⁾ <i>SIG.ERROR</i>	Configuration of signal level fault detection
Digital input ⁵⁾ <i>BINARY.IN</i>	Configuration of the digital input
Analog output ⁵⁾ <i>OUTPUT</i>	Configuration of the analog output (variant)

Table 5: Auxiliary functions

5) Only for variant without fieldbus communication.

5.7 Interfaces of the positioner

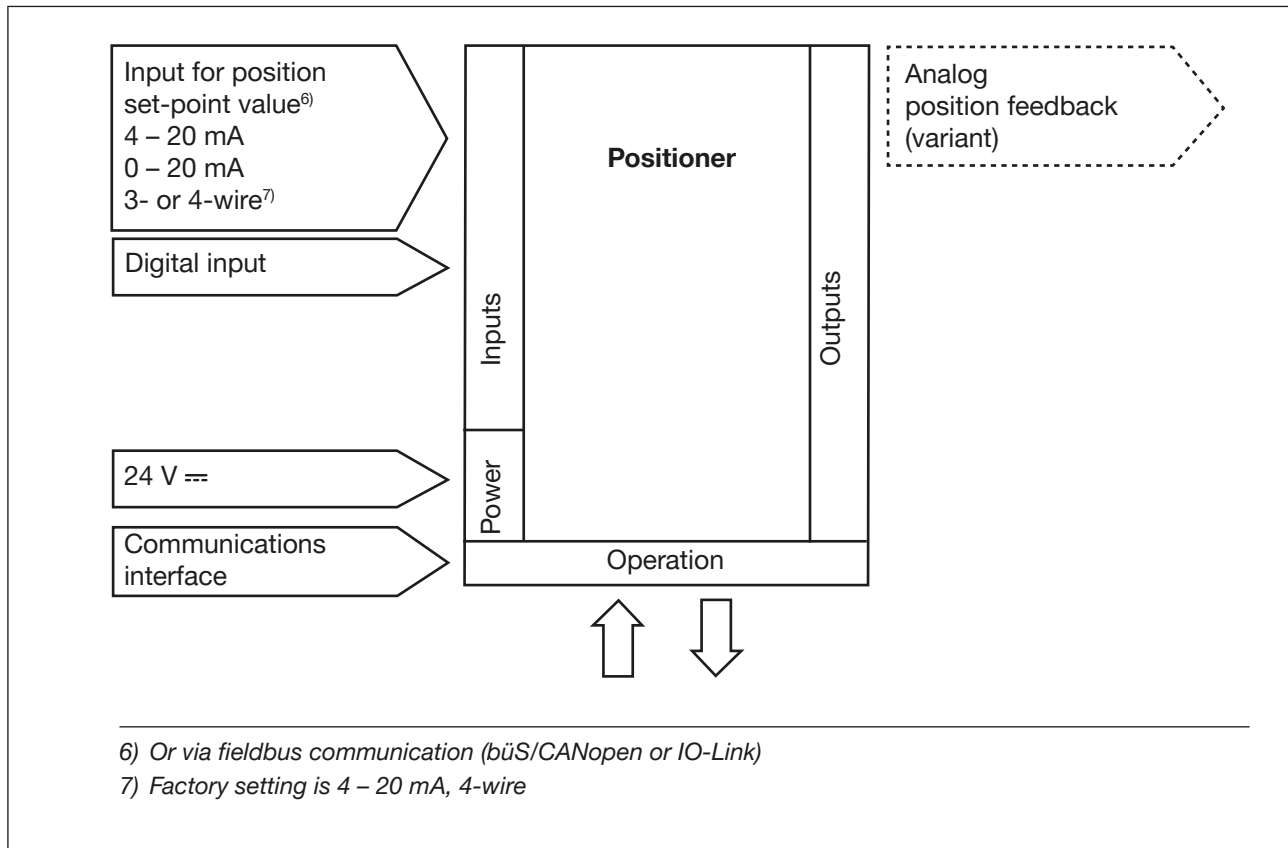

Figure 7: Interfaces



The positioner Type 8696 must be operated in 3-wire or 4-wire connection, i.e. the power (24 V =) is supplied separately from the set-point value signal.

- Input for position set-point value⁸⁾ (4 – 20 mA corresponds to 0 – 100 %).
- Digital input⁸⁾
If a voltage > 10 V is applied, safety position (SAFEPOS) is activated, i.e. the valve is moved to the safety position (factory setting, can be changed with communications software).
- Analog position feedback (variant)⁸⁾
The position of the valve can be transmitted via an analog 4 – 20 mA output to the PLC (4 – 20 mA corresponds to 0 – 100 %).

8) Only for variant without fieldbus communication.

6 TECHNICAL DATA

6.1 Standards and guidelines

The device complies with the relevant EU harmonisation legislation. In addition, the device also complies with the requirements of the laws of the United Kingdom.

The harmonised standards that have been applied for the conformity assessment procedure are listed in the current version of the EU Declaration of Conformity/UK Declaration of Conformity.

6.2 Licenses

The product is approved for use in zone 2 and 22 in accordance with ATEX directive 2014/34/EU category 3GD.



Observe instructions on operation in a potentially explosive atmosphere.
Observe the ATEX additional instructions.

The product is cULus approved. Instructions for use in the UL area see chapter [“6.8 Electrical data”](#).

6.3 Operating conditions



WARNING!

Solar radiation and temperature fluctuations may cause malfunctions or leaks.

- ▶ If the device is used outdoors, do not expose it unprotected to the weather conditions.
- ▶ Ensure that the permitted ambient temperature does not exceed the maximum value or drop below the minimum value.

Ambient temperature: See type label

Degree of protection:

Evaluated by the manufacturer:	Evaluated by UL:
IP65 / IP67 according to EN 60529 ⁹⁾	UL Type 4x Rating, indoor only ⁹⁾

Operating altitude: up to 2000 m above sea level

Relative air humidity: max. 90% at 55 °C (non condensing)

⁹⁾ Only if cables, plugs and sockets have been connected correctly and in compliance with the exhaust air concept, see chapter [“9 Pneumatic installation”](#).

6.4 Mechanical data

Dimensions		See data sheet
Housing material	exterior: interior:	PPS, PC, stainless steel, PA 6; ABS
Sealing material		EPDM / FKM
Stroke range of valve spindle:		2103 and 23xx series: 3 – 32 mm
		Third-party devices: (modified guide element required) 3 – 40 mm

6.5 Pneumatic data

Control medium		Neutral gases, air Quality classes in accordance with ISO 8573-1
Dust content	Quality class 7	max. particle size 40 µm, max. particle density 10 mg/m ³
Water content	Quality class 3	max. pressure dew point -20 °C or min. 10 °C below the lowest operating temperature
Oil content	Quality class X	max. 25 mg/m ³
Temperature range		-10 – + 50 °C
Pressure range		3 – 7 bar
Air output, pilot valve		7 l _N /min (for aeration and deaeration) (Q _{Nn} value according to definition for pressure drop from 7 to 6 bar absolute)
Connections	23xx / 2103 (Element)	Plug-in hose connector Ø 6 mm / 1/4" Threaded port G1/8
Model third-party device:		Socket connection G1/8 with M5 connection for connecting to the third-party device

6.6 Type label

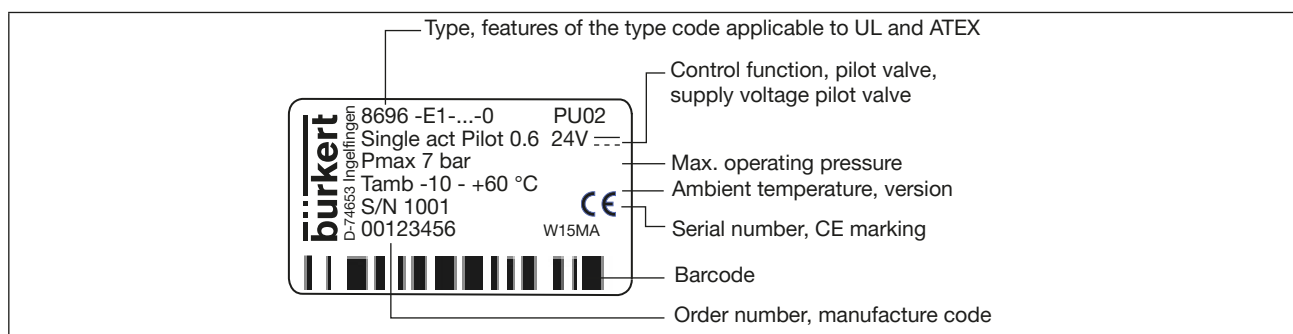

Figure 8: Example of type label

6.7 UL additional label

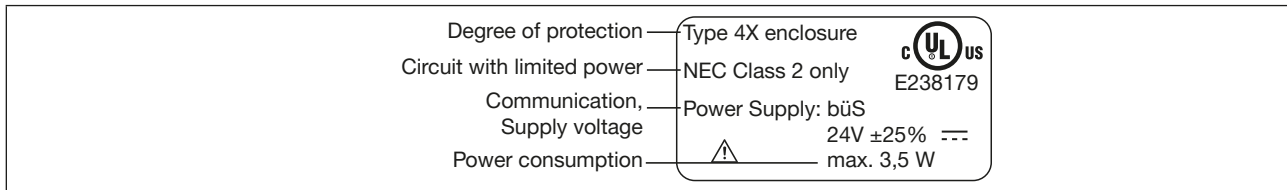

Figure 9: UL additional label (example)

6.8 Electrical data



WARNING!

Only circuits with limited power may be used for UL approved components according to "NEC Class 2".

6.8.1 Electrical data, without fieldbus communication

Protection class	III as per DIN EN 61140 (VDE 0140-1)
Connections	Circular plug-in connector (M12 x 1, 8-pin)
Operating voltage	24 V \pm 25%, max. residual ripple 10 %
Current consumption	max. 150 mA
Power consumption	max. 3.5 W
Input resistance for set-point value signal	75 Ω at 0/4 – 20 mA / 12 bit resolution
Analogue position feedback max. load for current output 0/4 – 20 mA	560 Ω
Digital input	0 – 5 V = log "0", 12 – 30 V = log "1" inverted input in reverse order
Communications interface	Connection to PC via USB bus interface set
Communication software	Bürkert Communicator

6.8.2 Electrical data, IO-Link

Protection class	III as per DIN EN 61140 (VDE 0140-1)
Connection	Circular plug-in connector M12 x 1, 5-pin, A-coded
Port Class A	
Operating voltage	24 V \pm 25 % (according to specification)
Current consumption	max. 150 mA
Port Class B	
Operating voltage	
System supply (Pin 1+3)	24 V \pm 25 % (according to specification)
Actuator supply (Pin 2+5) ¹⁰⁾	24 V \pm 25 % (according to specification)
Current consumption	
System supply (Pin 1+3)	max. 50 mA
Actuator supply (Pin 2+5)	max. 100 mA
Total power consumption	max. 3.5 W

¹⁰⁾ Actuator supply is galvanically isolated from system supply in accordance with IEC 60664 and for electrical safety in accordance with SELV from IEC 61010-2-201

6.8.3 Electrical data, bÜS

Protection class	III as per DIN EN 61140 (VDE 0140-1)
Connection	Circular plug-in connector M12 x 1, 5-pin, A-coded
Operating voltage	24 V \pm 25 %
Current consumption	max. 150 mA
Total power consumption	max. 3.5 W

6.9 Factory settings of the positioner

Functions can be activated via buttons:

Function	Parameter	Value
<i>CUTOFF</i>	Sealing function below Sealing function above	2 % 98 %
<i>CHARACT</i>	Characteristic correction	FREE ¹¹⁾

Table 6: Factory settings

Functions can be activated via communications software:

Function	Parameter	Value
<i>INPUT</i> ⁶⁾	Set-point value input	4 – 20 mA, 4-wire
<i>DIR.CMD</i>	Reversal of the effective direction set-point value	Off
<i>DIR.ACT</i>	Reversal of the effective direction of the actuator	Off
<i>SPLTRNG</i> Function deactivated	Signal split range below Signal split range above	0 % 100 %
<i>X.LIMIT</i> Function deactivated	Stroke limit below Stroke limit above	0 % 100 %
<i>X.TIME</i> Function deactivated	Actuating time Open Actuating time Closed	(1 s) values determined by <i>X.TUNE</i> (1 s) values determined by <i>X.TUNE</i> After implementation of <i>RESET</i> : 1 s
<i>X.CONTROL</i>	Deadband Open amplification factor Close amplification factor	2.0 % (1) values determined by <i>X.TUNE</i> (1) values determined by <i>X.TUNE</i> After implementation of <i>RESET</i> : 1
<i>SAFEPOS</i>	Safety position	0 %
<i>SIG.ERROR</i> ¹²⁾ Function deactivated	Cable break detection set-point value	Deactivated
<i>BINARY.IN</i> ¹²⁾	Digital input function Operating principle of digital input	Safety position Normally open
<i>OUTPUT</i> ¹²⁾ (variant)	Norm signal output: Parameter Norm signal output: Type	Position (POS) 4 – 20 mA

Table 7: Factory settings

11) Without change to the settings via the communications software a linear characteristic is stored.

12) Only for variant without fieldbus communication

7 CONTROL AND DISPLAY ELEMENTS

The following chapter describes the operating states as well as the control and display elements of the positioner. For further information on the operation of the positioner, refer to chapter [“11 Start-up”](#).

7.1 Operating state



To operate the buttons, make sure that the local control lock is deactivated/unlocked (factory setting): with communication software or fieldbus communication.

AUTOMATIC (AUTO)

Normal controller mode is implemented and monitored in AUTOMATIC operating state.

MANUAL (MANU)

In MANUAL operating state the valve can be opened and closed manually via the buttons.

The manual LED is lit red.

The buttons can be used to switch between the two operating states AUTOMATIC and MANUAL:

→ Press both buttons simultaneously between 2 s and 10 s (manual LED flashes at 5 Hz).

7.2 Control and display elements of the positioner

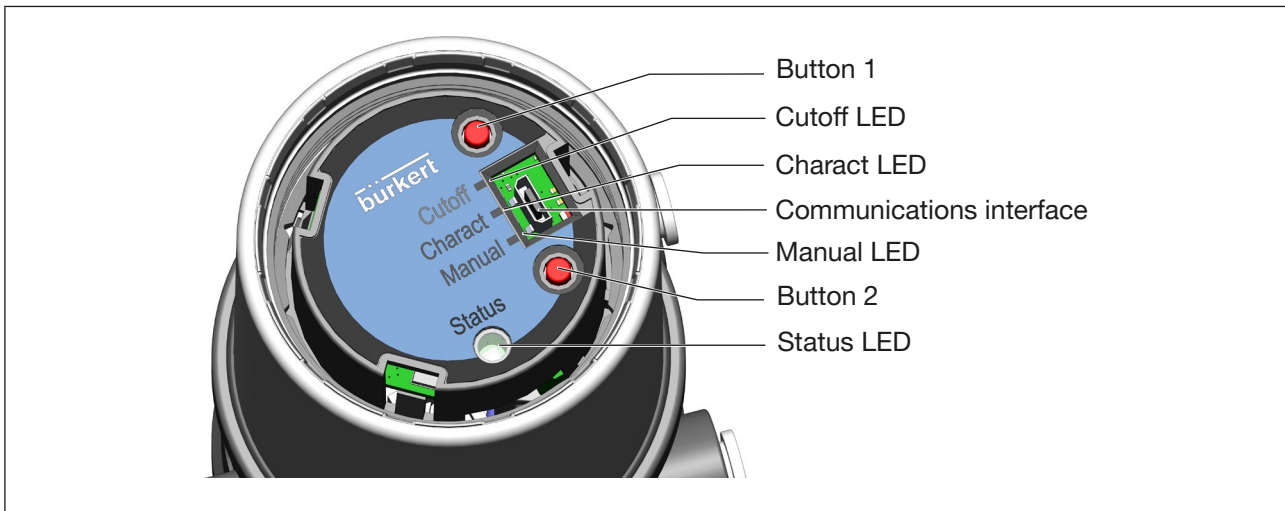

Figure 10: Description of the control elements

ATTENTION!

Breakage of the pneumatic connection pieces due to rotational impact.

- ▶ When unscrewing and screwing in the transparent cap, do not hold the actuator of the process valve but the basic housing.

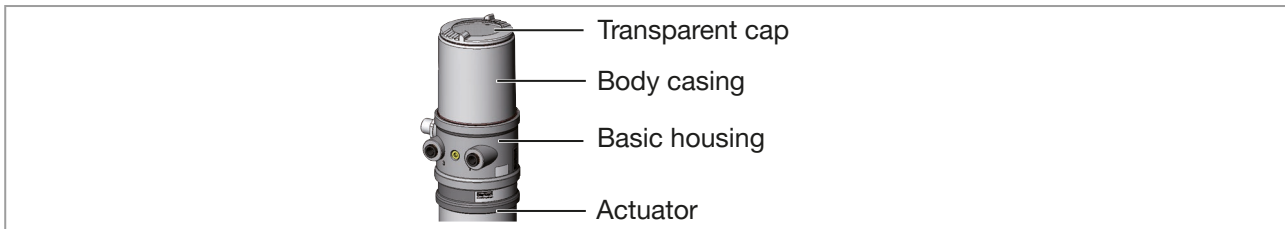

Figure 11: Open positioner

→ Screw off the transparent cap of the positioner to operate the buttons.

ATTENTION!

Damage or malfunction due to penetration of dirt and humidity.

- ▶ To observe degree of protection IP65 / IP67, screw the transparent cap in all the way.

→ Close the device (assembly tool: 674078¹³⁾).

¹³⁾ The assembly tool (674078) is available from your Bürkert sales office.

7.3 Configuration of the buttons

! To operate the buttons, make sure that the local control lock is deactivated/unlocked (factory setting): with communication software or fieldbus communication.

The configuration of the 2 buttons varies depending on the operating state (AUTOMATIC / MANUAL).

The description of the operating states (AUTOMATIC / MANUAL) can be found in the chapter entitled “7.1 Operating state”.



Figure 12: Description of the buttons

ATTENTION!

Breakage of the pneumatic connection pieces due to rotational impact.

- ▶ When unscrewing and screwing in the transparent cap, do not hold the actuator of the process valve but the basic housing.

→ To operate the buttons unscrew the transparent cap.

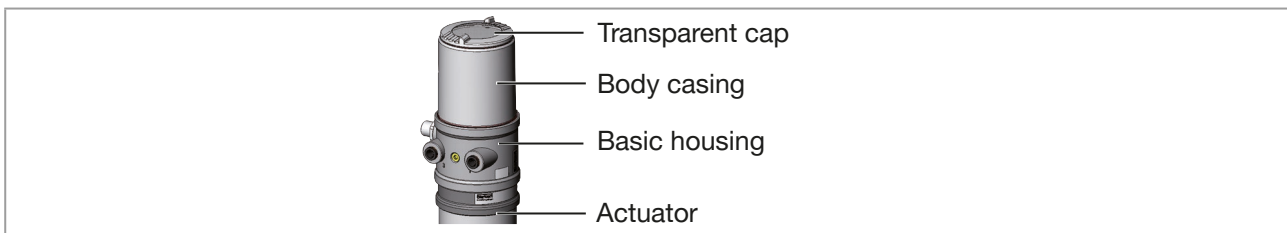

Figure 13: Open positioner

ATTENTION!

Damage or malfunction due to penetration of dirt and humidity.

- ▶ To observe degree of protection IP65 / IP67, screw the transparent cap in all the way.

→ Close the device (assembly tool: 674078¹⁴⁾).

¹⁴⁾ The assembly tool (674078) is available from your Bürkert sales office.

MANUAL operating status (manual LED is lit red):

Button		Function	LED
1	Press and hold	Aerate (manually open / close the actuator) ¹⁵⁾	
2	Press and hold	Deaerate (manually open / close the actuator) ¹⁵⁾	
1 and 2 simultane- ously	Press longer than 2 s (< 10 s)	Switching to AUTOMATIC operating state	Manual LED flashes at 5 Hz (0 – 2 s)
	Press longer than 10 s (< 30 s)	Device restart	Manual LED, charact LED and cutoff LED flash at 5 Hz (10 – 30 s)
	Press longer than 30 s	Reset device to factory setting	Manual LED, charact LED and cutoff LED flash at 10 Hz (> 30 s)

Table 8: Configuration of the buttons for MANUAL operating status

AUTOMATIC operating state (manual LED is not lit):

Button		Function	LED
1	Press longer than 2 s (< 5 s)	Activates/deactivates CUTOFF function	Cutoff LED flashes at 5 Hz (0 – 2 s) and at 10 Hz (2 – 5 s) CUTOFF function aktive: cutoff LED is lit
	Press longer than 5 s	Starting the X.TUNE function	Status LED is lit orange
2	Press longer than 2 s	Activates/deactivates CHARACT function	Charact LED flashes at 5 Hz (0 – 2 s) and at 10 Hz (2 – 5 s) CHARACT function aktive: charact LED is lit
1 and 2 simultane- ously	Press longer than 2 s (< 10 s)	Switching to MANUAL operating state	Manual LED flashes at 5 Hz (0 – 2 s) Operating state MANUAL aktive: manual LED is lit
	Press longer than 10 s (< 30 s)	Device restart	Manual LED, charact LED and cutoff LED flash at 5 Hz (10 – 30 s)
	Press longer than 30 s	Reset device to factory setting	Manual LED, charact LED and cutoff LED flash at 10 Hz (> 30 s)

Table 9: Configuration of the buttons for AUTOMATIC operating status

¹⁵⁾ Depending on the operating principle of the actuator.

7.4 Display of the LEDs

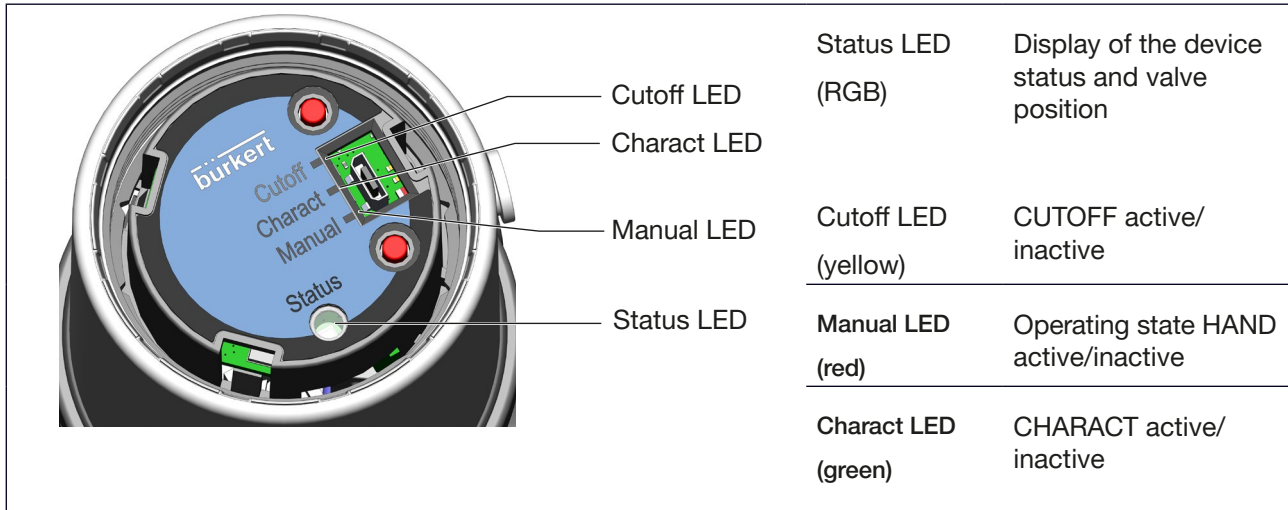

Figure 14: Display of the LEDs

7.4.1 Cutoff LED

Color	Status	Description
yellow	is lit	CUTOFF active
yellow	is not lit	CUTOFF inactive

Table 10: Cutoff LED

7.4.2 Manual LED

Color	Status	Description
red	is lit	Operating state HAND active
red	is not lit	Operating state AUTOMATIC active

Table 11: Manual LED

7.4.3 Charact LED

Color	Status	Description
green	is lit	CHARACT active
green	is not lit	CHARACT inactive

Table 12: Charact LED

7.4.4 Status indicator

The status LED (RGB) show the device status.

The user can set the following LED modes for the display of device status and valve position.

- NAMUR mode
- Valve mode
- Valve mode with warnings (factory setting)
- Fixed color
- LED off

The LED mode and the colors of the valve position can be set with the Bürkert Communicator.

IO-Link:

The LED mode and the colors of the valve position can be also set with an acyclic parameter (see parameter list).



The description for setting the LED mode can be found in the chapter [“14.2.10 Setting the LED mode, device status”](#).

7.4.4.1 Valve mode

Displays in valve mode:

- Valve position: open, half-way, closed
- Device status: Error

Valve position	Valve position status, color	Device status: Error status, color	
Open	is lit yellow*	flashes red	alternately with yellow*
Half-way	LED off*	flashes red	alternately with LED off*
Closed	is lit green*	flashes red	alternately with green*

Table 13: Valve mode

7.4.4.2 Valve mode + warnings

Displays in valve mode + warnings:

- Valve position: open, half-way, closed
- Device status: failure, function check, out of specification, maintenance required (according to NAMUR)

Valve position	Device status	
	Status, color	Normal operation
Open	is lit yellow*	--
Half-way	LED off*	--
Closed	is lit green*	--

Table 14: Valve mode + warnings, normal operation

* Factory setting, selectable colors for the valve position: Off, white, green, blue, yellow, orange, red

If several device statuses exist simultaneously, the device status with the highest priority is displayed.

Valve position	Device status				
	Failure	Function check	Out of specification	Maintenance required	
	Status, color	Status, color	Status, color	Status, color	
Open	flashes red	flashes orange	flashes yellow	flashes blue	alternately with yellow*
Half-way	flashes red	flashes orange	flashes yellow	flashes blue	alternately with LED off*
Closed	flashes red	flashes orange	flashes yellow	flashes blue	alternately with green*

Table 15: Valve mode + warnings, device status

For warning messages, the LEDs are briefly switched off between the change of the colors.

For localizations, the colors are only shown momentarily.

7.4.4.3 NAMUR mode

The device status LED show the device status.

The display elements change color in accordance with NAMUR NE 107.

If several device statuses exist simultaneously, the device status with the highest priority is displayed. The priority is determined by the severity of the deviation from controlled operation (red LED = failure = highest priority).

Status display in accordance with NE 107, edition 2006-06-12			
Color	Color code	Status	Description
Red	5	Outage, error or malfunction	Normal operation is not possible due to a malfunction in the device or on its peripheral equipment.
Orange	4	Function check	Work is being carried out on the device; normal operation is therefore temporarily not possible
Yellow	3	Out of specification	Ambient conditions or process conditions for the device are outside the specified area.
Blue	2	Maintenance required	The device is in normal operation, although a function is briefly restricted. →Service device.
Green	1	Diagnostics active	Device is operating perfectly. Status changes are indicated in different colors. Messages are transmitted via a fieldbus if connected.

Table 16: Description of the colors

* Factory setting, selectable colors for the valve position: Off, white, green, blue, yellow, orange, red

7.5 Error messages

7.5.1 Messages for device status “Out of specification“

Message	Description	Procedure
Temperature limit exceeded	Ambient temperature is too high	Reduce ambient temperature. If problems continue, contact your Bürkert Service Center
Temperature limit not achieved	Ambient temperature is too low	Increase ambient temperature
Voltage limit exceeded	Supply voltage is too high	Check supply voltage
Voltage limit not achieved	Supply voltage is too low	Check supply voltage
CMD sensor break	Cable break of the set-point value signal. The message can be parameterized	Check the signal line of the set-point value

Table 17: Messages

7.5.2 Messages: Actuator moves to safety position

Message	Description	Procedure
Excess temperature detected	Device temperature is too high for operation	Reduce ambient temperature. If problems continue, contact your Bürkert Service Center
Insufficient temperature detected	Device temperature is too low for operation	Increase ambient temperature
Excess voltage detected	Supply voltage is too high for operation	Check supply voltage
Insufficient voltage detected	Failure of the supply voltage or supply voltage is too low for operation	Check supply voltage. If problems continue, contact your Bürkert Service Center
Persistent memory cannot be used: Defective or not available	Writing or reading error of the internal data storage EEPROM	Restart device. If problems continue, contact your Bürkert Service Center
BueS event: Producer(s) not found	Assigned external bÜS producer cannot be found	Check signal to bÜS partner
BueS event: Bus connection lost / not available	bÜS network cannot be found	Check bÜS network
BueS event: Producer is not operational	Producer is not operational in the status	Check bÜS producer
BueS event: A device is using the same address	Another bÜS participant is using the same address	Assign device and bÜS participant a unique address

IO-Link error	No valid process data is received	- Check connection to the IO-Link master - Check whether valid setpoints are sent to the device via the IO-Link interface
X.TUNE error occurred	The last X.TUNE was not successful	-Check compressed air supply -Run X.TUNE again
Actuator supply is down	The actuator supply voltage is too low. Only with IO-Link	Check actuator supply voltage
POS.Monitor	The set-point position is not reached	-Run X.TUNE -Check compressed air supply.
CMD sensor break	Cable break of the set-point value signal. The message can be parameterized	Check the signal line of the set-point value

Table 18: Messages

8 INSTALLATION

8.1 Safety instructions



DANGER!

Risk of injury from high pressure in the equipment/device.

- ▶ Before working on equipment or device, switch off the pressure and deaerate/drain lines.

Risk of electric shock.

- ▶ Before working on equipment or device, switch off the power supply and secure to prevent reactivation.
- ▶ Observe applicable accident prevention and safety regulations for electrical equipment.



WARNING!

Risk of injury from improper installation.

- ▶ Installation may be carried out by authorised technicians only and with the appropriate tools.

Risk of injury from unintentional activation of the system and an uncontrolled restart.

- ▶ Secure system from unintentional activation.
- ▶ Following assembly, ensure a controlled restart.

8.2 Installation of the positioner Type 8696 to process valves of series 2103, 2300 and 2301

ATTENTION!

When mounting on process valves with a welded connection, follow the installation instructions in the operating instructions for the process valve.

Procedure:

1. Install switch spindle

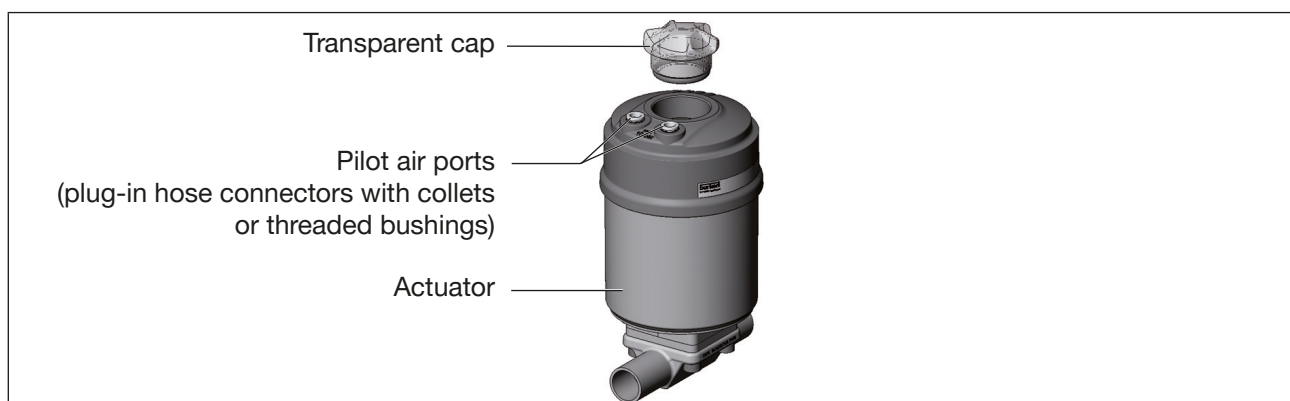

Figure 15: Installation of positioner, series 2103, 2300 and 2301

→ Unscrew the transparent cap on the actuator and unscrew the position display (yellow cap) on the spindle extension (if present).

→ For version with plug-in hose connector, remove the collets (white nozzles) from both pilot air ports (if present).

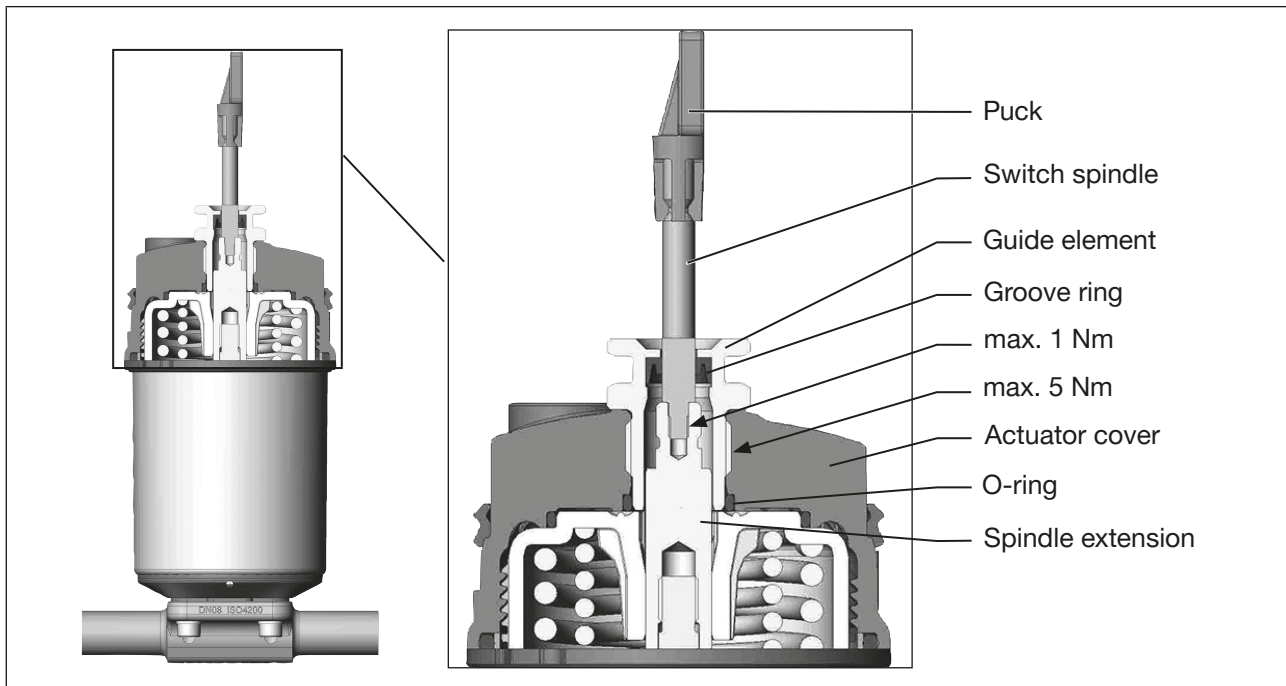

Figure 16: Installing the switch spindle, series 2103, 2300 and 2301

ATTENTION!

Improper installation may damage the groove ring in the guide element.

The groove ring is already be pre-assembled in the guide element and must be “locked into position” in the undercut.

- ▶ When installing the switch spindle, do not damage the groove ring.

→ Push the switch spindle through the guide element.

ATTENTION!

Screw locking paint may contaminate the groove ring.

- ▶ Do not apply any screw locking paint to the switch spindle.

→ To secure the switch spindle, apply some screw locking paint (Loctite 290) in the tapped bore of the spindle extension in the actuator.

→ Check that the O-ring is correctly positioned.

→ Screw the guide element to the actuator cover (maximum torque: 5 Nm).

→ Screw switch spindle onto the spindle extension. To do this, there is a slot on the upper side (maximum torque: 1 Nm).

→ Push puck onto the switch spindle and lock into position.

2. Install sealing rings

- Pull the form seal onto the actuator cover (smaller diameter points upwards).
- Check that the O-rings are correctly positioned in the pilot air ports.



When the positioner is being installed, the collets of the pilot air ports must not be fitted to the actuator.

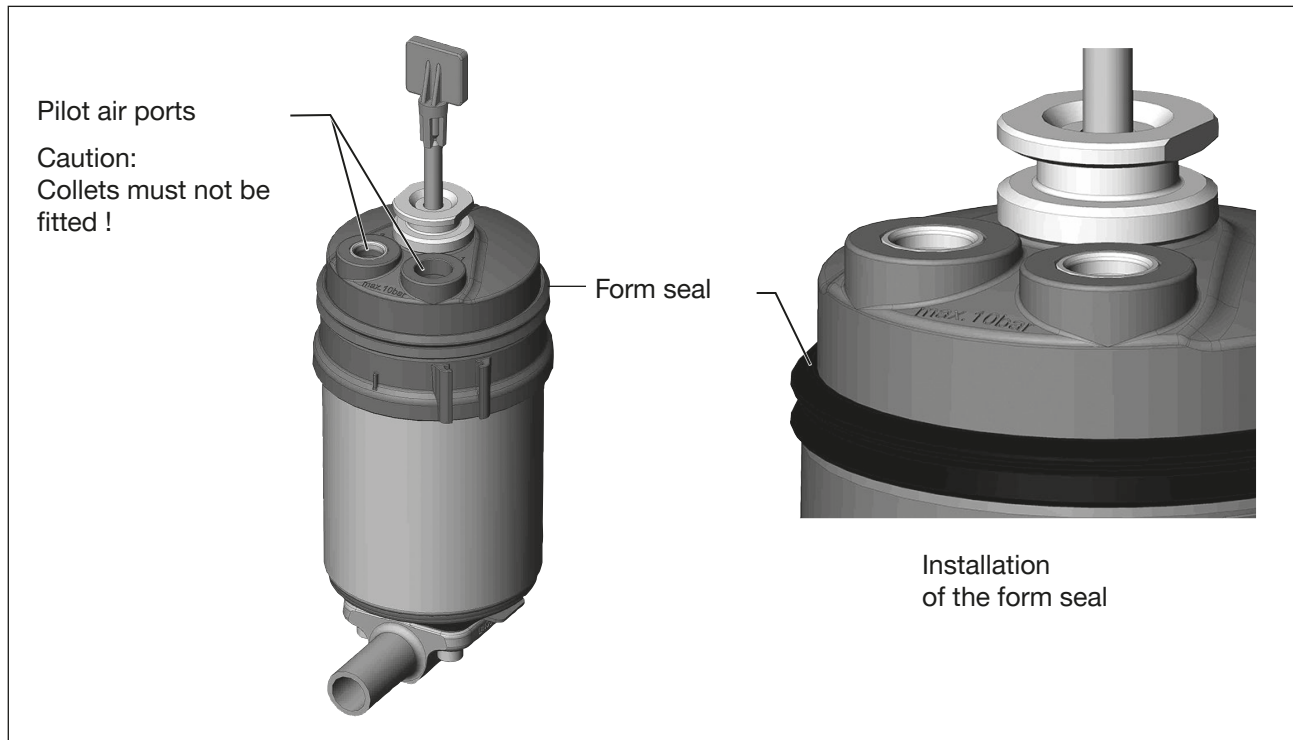

Figure 17: Installation of the sealing rings

3. Install positioner

- Align the puck and the positioner until
 1. the puck can be inserted into the guide rail of the positioner and
 2. the connection pieces of the positioner can be inserted into the pilot air ports of the actuator (see also "Figure 19").

ATTENTION!

Damaged printed circuit board or malfunction.

- ▶ Ensure that the puck is situated flat on the guide rail.

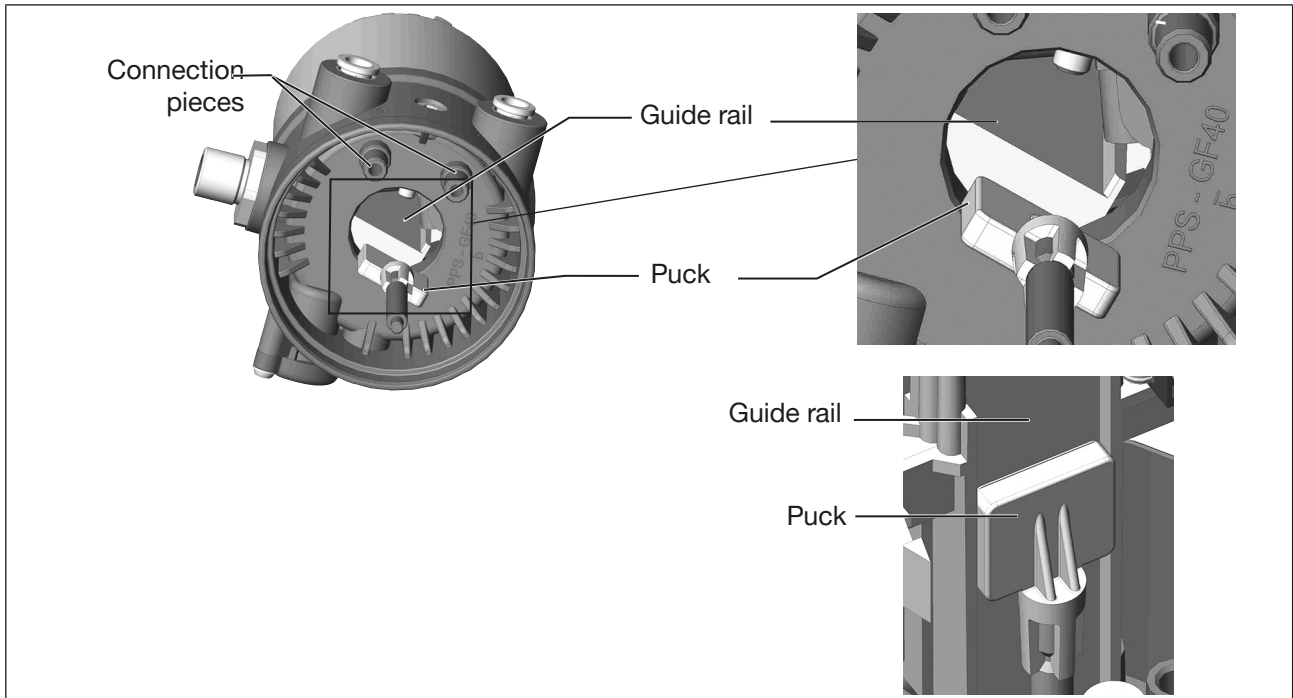

Figure 18: Aligning the puck

→ Push the positioner, without turning it, onto the actuator until no gap is visible on the form seal.

ATTENTION!

Too high torque when screwing in the fastening screw does not ensure degree of protection IP65 / IP67.

▶ The fastening screws may be tightened to a maximum torque of 1.5 Nm only.

→ Attach the positioner to the actuator using the two side fastening screws. In doing so, tighten the screws only hand-tight (max. torque: 1.5 Nm).

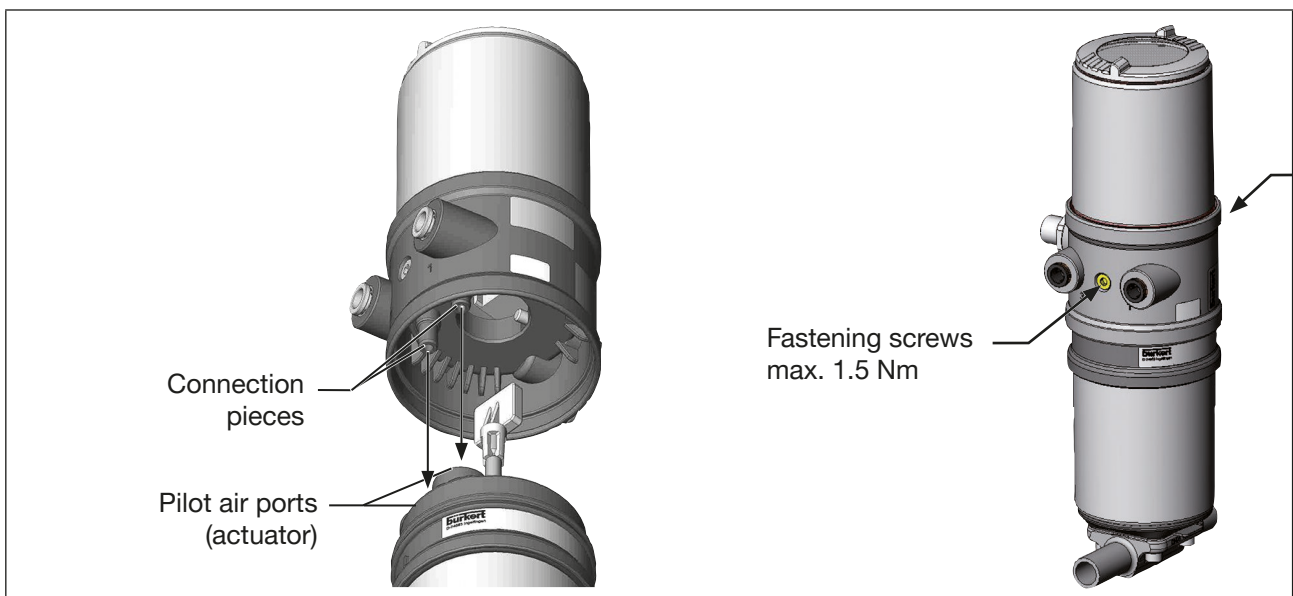

Figure 19: Installation of the positioner

8.3 Rotating the actuator module for process valves belonging to series 2300 and 2301

! The actuator module (positioner and actuator) can be rotated for straight seat valves and angle seat valves belonging to series 2300 and 2301 only.

The position of the connections can be aligned steplessly by rotating the actuator module (positioner and actuator) through 360°.

! Only the entire actuator module can be rotated. The positioner cannot be rotated contrary to the actuator.
The process valve must be in the open position for alignment of the actuator module.

! DANGER!

Risk of injury from high pressure in the equipment/device.

- ▶ Before working on equipment or device, switch off the pressure and deaerate/drain lines.

Procedure:

- Clamp valve body in a holding device (only required if the process valve has not yet been installed).
- Control function A: Open process valve.

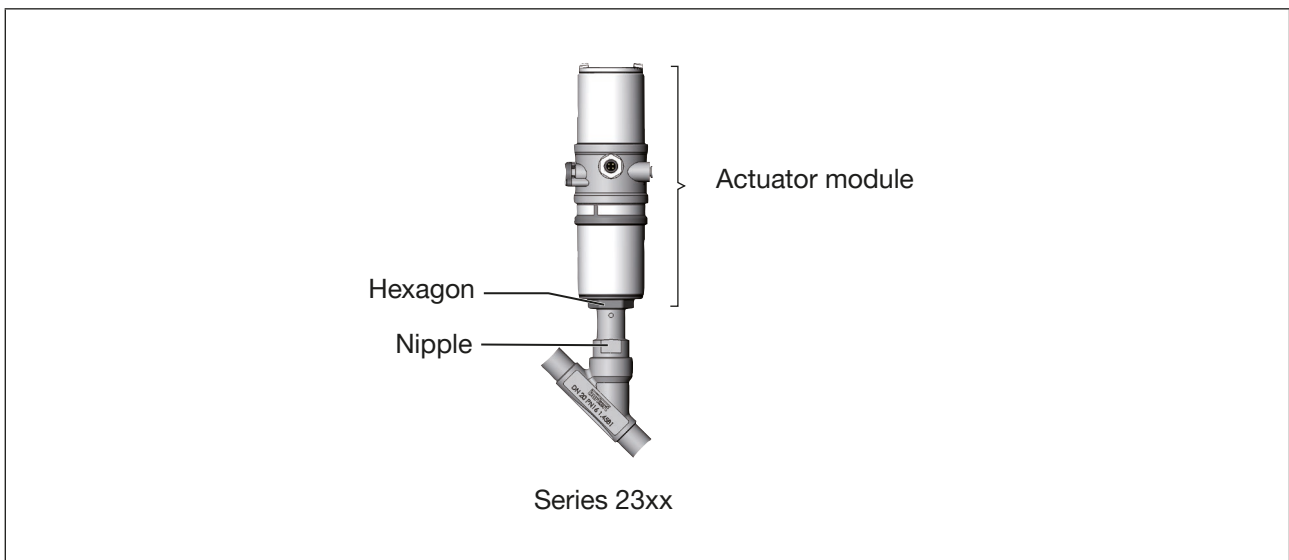

Figure 20: Rotating the actuator module

- Using a suitable open-end wrench, counter the wrench flat on the pipe.
- Place suitable open-end wrench on the hexagon of the actuator.



WARNING!

Risk of injury from discharge of medium and pressure.

If the direction of rotation is wrong, the body interface may become detached.

- ▶ Rotate the actuator module counter-clockwise only (see “Figure 21”).

- Rotate counter-clockwise (as seen from below) to bring the actuator module into the required position.

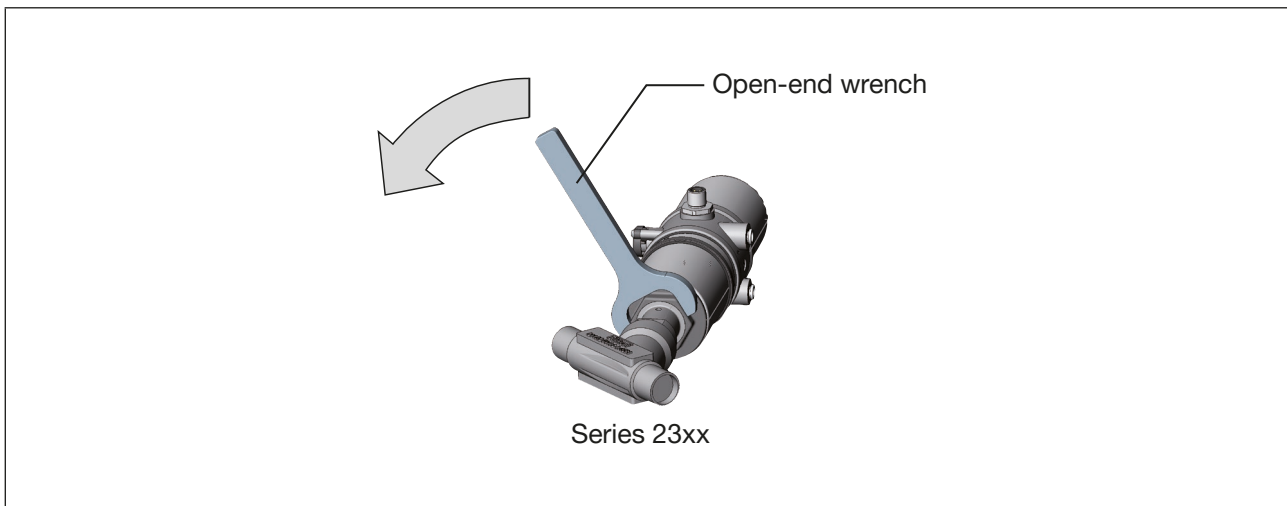

Figure 21: Rotating open-end wrench

9 PNEUMATIC INSTALLATION

DANGER!

Risk of injury from high pressure in the equipment/device.

- ▶ Before working on equipment or device, switch off the pressure and deaerate/drain lines.

WARNING!

Risk of injury from improper installation.

- ▶ Installation may be carried out by authorised technicians only and with the appropriate tools.

Risk of injury from unintentional activation of the system and an uncontrolled restart.

- ▶ Secure system from unintentional activation.
- ▶ Following installation, ensure a controlled restart.

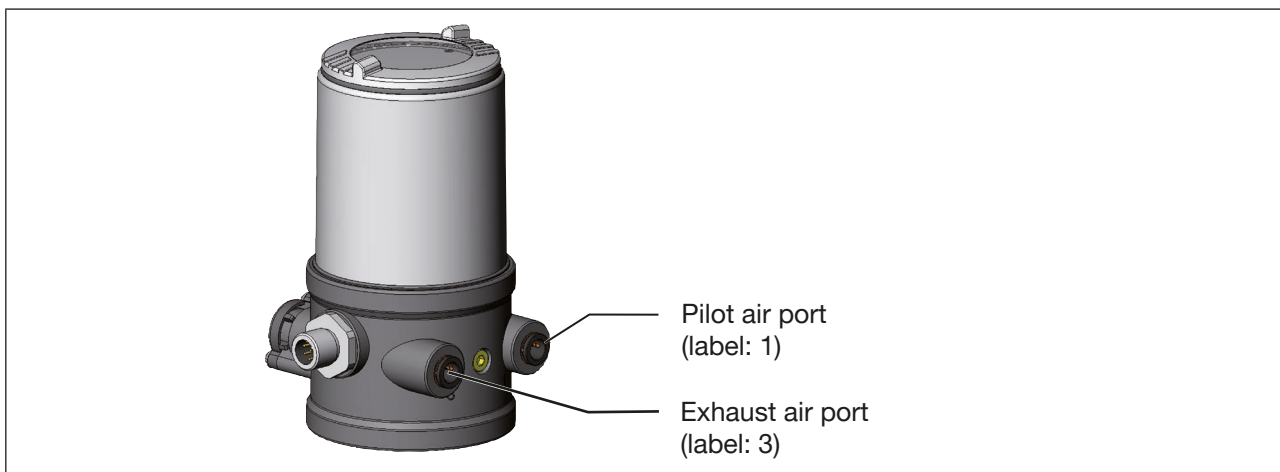

Figure 22: Pneumatic connection

Procedure:

- Connect the control medium to the pilot air port (1)
(3 – 7 bar; instrument air, free of oil, water and dust).
- Attach the exhaust airline or a silencer to the exhaust air port (3).



Caution: (Exhaust air concept):

- ▶ In compliance with degree of protection IP67, an exhaust air line must be installed in the dry area.



Important information for the problem-free functioning of the device:

- ▶ The installation must not cause back pressure to build up.
- ▶ Select a hose for the connection with an adequate cross-section.
- ▶ The exhaust air line must be designed in such a way that no water or other liquid can get into the device through the exhaust air port.
- ▶ Keep the adjacent supply pressure **always** at least 0.5 – 1 bar above the pressure which is required to move the actuator to its end position. This ensures that the control behavior is not extremely negatively affected in the upper stroke range on account of too little pressure difference.
- ▶ During operation keep the fluctuations of the pressure supply as low as possible (max. $\pm 10\%$). If fluctuations are greater, the control parameters measured with the *X.TUNE* function are not optimum.

10 ELECTRICAL INSTALLATION

All electrical inputs and outputs of the device are not galvanically isolated from the supply voltage.

10.1 Safety instructions



DANGER!

Risk of electric shock.

- ▶ Before working on equipment or device, switch off the power supply and secure to prevent reactivation.
- ▶ Observe applicable accident prevention and safety regulations for electrical equipment.



WARNING!

Risk of injury from improper installation.

- ▶ Installation may be carried out by authorized technicians only and with the appropriate tools.

Risk of injury from unintentional activation of the system and an uncontrolled restart.

- ▶ Secure system from unintentional activation.
- ▶ Following installation, ensure a controlled restart.

Minimum temperature rating of the cable to be connected to the field wiring terminals: 75 °C

10.2 Electrical installation without fieldbus communication

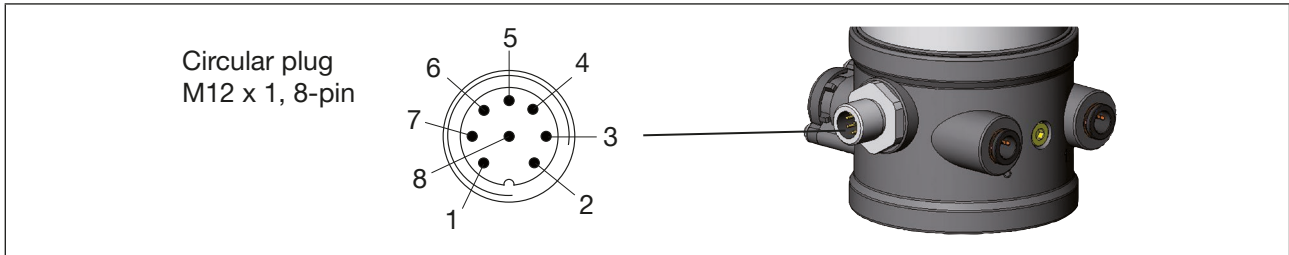

Figure 23: Circular plug M12 x 1, 8-pin

→ Connect the pins according to the model of the positioner.

Input signals of the control center (e.g. PLC), circular plug M12 x 1, 8-pin

Pin	Wire color ¹⁶⁾	Configuration	external circuit / signal level
1	white	Set-point value + (0/4 – 20 mA)	1 ○ — + (0/4 – 20 mA)
2	brown	Set-point value GND	2 ○ — GND see table connection type 3-wire or 4-wire
5	grey	Digital input +	5 ○ — +
6	pink	Digital input -	6 ○ — GND

Table 19: Pin assignment, input signals of the control center, circular plug M12 x 1, 8-pin

Connection type 3-wire or 4-wire (setting via communication software):

Connection type 4-wire (factory setting)	Connection type 3-wire
<p>The set-point value input is designed as a differential input, i.e. the GND lines of the set-point value input and the supply voltage are not identical.</p> <p>Note: If the GND signals of the set-point value input and the supply voltage are connected, the 3-wire connection type must be set in the software.</p>	<p>The set-point value input is related to the GND line of the supply voltage, i.e. setpoint input and supply voltage have a common GND line.</p>

Table 20: Connection type

16) The indicated colors refer to the connecting cable available as an accessory (919061)

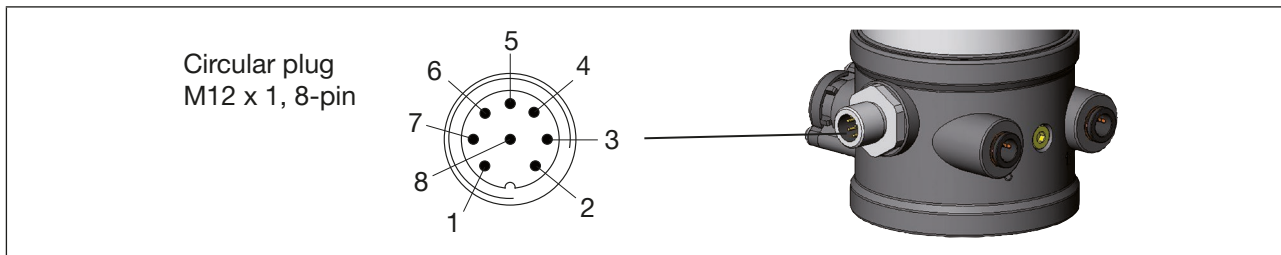

Figure 24: Circular plug M12 x 1, 8-pin

**Output signals to the control center (e.g. PLC), circular plug M12 x 1, 8-pin
(required for analogue output variant only)**

Pin	Wire color ¹⁷⁾	Configuration	external circuit / signal level
8	red	Analogue position feedback +	8 + (0/4 – 20 mA)
7	blue	Analogue position feedback GND	7 GND

Table 21: Pin assignment, output signals of the control center, circular plug M12 x 1, 8-pin

Operating voltage (circular plug M12 x 1, 8-pin)

Pin	Wire color ¹⁷⁾	Configuration	External circuit
4	yellow	+ 24 V	 24 V \pm 25 % max. residual ripple 10 %
3	green	GND	

Table 22: Pin assignment, operating voltage (circular plug M12 x 1, 8-pin)

MAN 1000417068 EN Version: B Status: RL (released | freigegeben) printed: 24.04.2026

17) The indicated colors refer to the connecting cable available as an accessory (919061)

10.3 Electrical installation, IO-Link

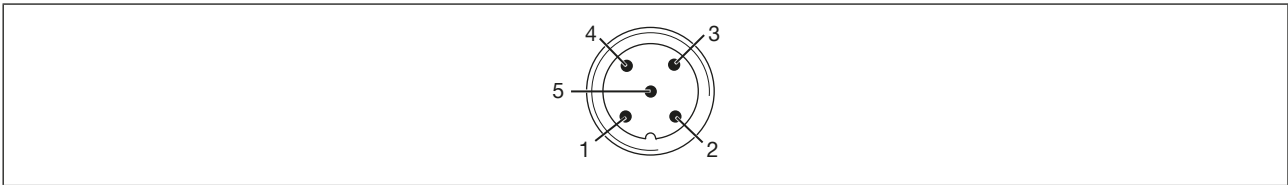

Figure 25: Pin assignment

Pin assignment, Port Class A

Pin	Designation	Configuration	
1	L +	24 V $\overline{=}$	System supply
2	I/Q	NC	Not used
3	L -	0 V (GND)	System supply
4	C/Q	IO-Link	Communication
5	NC	NC	Not used

Table 23: Pin assignment, Port Class A

Pin assignment, Port Class B

Pin	Designation	Configuration	
1	L +	24 V $\overline{=}$	System supply
2	P24	24 V $\overline{=}$	Actuator supply
3	L -	0 V (GND)	System supply
4	C/Q	IO-Link	Communication
5	N24	0 V (GND)	Actuator supply

Table 24: Pin assignment, Port Class B

10.4 Electrical Installation, bÜS

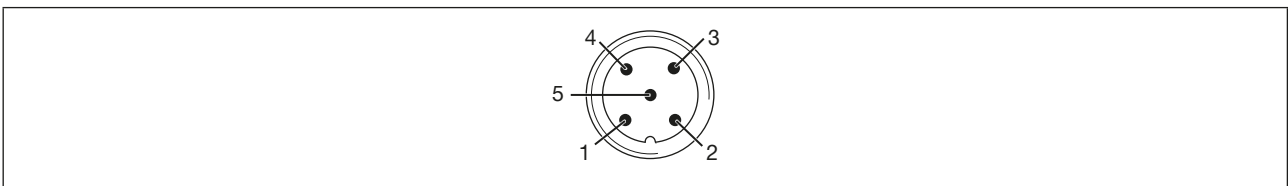

Figure 26: Pin assignment

Pin	Wire color	Configuration
1	CAN plate/shielding	CAN plate/shielding
2	red	+24 V $\overline{=}$ $\pm 25\%$, max. residual ripple 10%
3	black	GND / CAN_GND
4	white	CAN_H
5	blue	CAN_L

Table 25: Pin assignment



For electrical installation with bÜS network, note:

→ Use a 5-pin round plug and shielded 5-core cable.

The shielding in the device is not connected to the functional earth.

11 START-UP

11.1 Safety instructions



DANGER!

Risk of electric shock.

- ▶ Before working on equipment or device, switch off the power supply and secure to prevent reactivation.
- ▶ Observe applicable accident prevention and safety regulations for electrical equipment.



WARNING!

Risk of injury from improper operation.

Improper operation may result in injuries as well as damage to the device and the area around it.

- ▶ Before start-up, ensure that the operating personnel are familiar with and completely understand the contents of the operating instructions.
- ▶ Observe the safety instructions and intended use.
- ▶ Only adequately trained personnel may operate the equipment/the device.

11.2 Specifying the standard settings

The basic settings of the positioner are implemented at the factory.



To adjust the positioner to local conditions, the *X.TUNE* function must be run following installation.

11.2.1 Running the automatic adjustment *X.TUNE*



WARNING!

While the *X.TUNE* function is running, the valve automatically moves from its current position.

- ▶ Never run *X.TUNE* while a process is running.
- ▶ Take appropriate measures to prevent the equipment from being accidentally actuated.

ATTENTION!

Avoid maladjustment of the controller due to an incorrect pilot pressure or applied operating medium pressure.

- ▶ Run *X.TUNE* **whenever** the pilot pressure (= pneumatic auxiliary energy) is available during subsequent operation.
- ▶ Run the *X.TUNE* function preferably **without** operating medium pressure to exclude interference caused by flow forces.



To run *X.TUNE*, the positioner must be in the AUTOMATIC operating state (manual LED is not lit).

ATTENTION!

Breakage of the pneumatic connection pieces due to rotational impact.

- ▶ When unscrewing and screwing in the transparent cap, do not hold the actuator of the process valve but the basic housing.

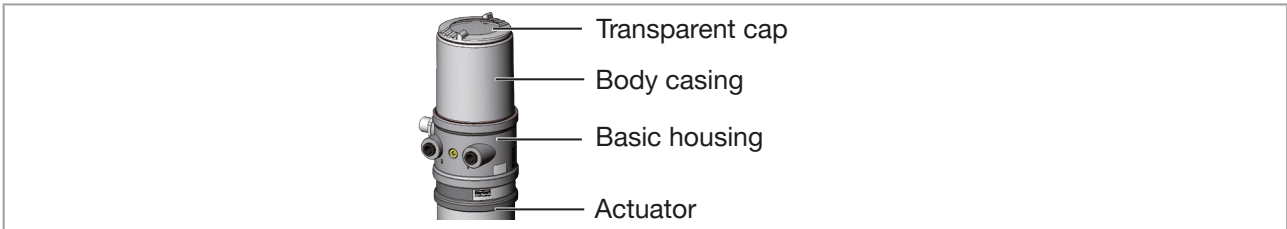

Figure 27: Open positioner

→ Screw off the transparent cap of the positioner to operate the buttons.

→ Start the X.TUNE by pressing button 1¹⁸⁾ for 5 s.

The device is in the NAMUR state function check, status LED lights orange.

If the X.TUNE is successfully completed, the NAMUR state is reset again. The changes are automatically transferred to the memory (EEPROM) provided the X.TUNE function is successful.

When status LED lights red after X.TUNE:

- Execute X.TUNE again.
- Perform a device restart if necessary.

The changes are automatically transferred to the memory provided the X.TUNE function is successful.

ATTENTION!

Damage or malfunction due to penetration of dirt and humidity.

- ▶ To observe degree of protection IP65 / IP67, screw the transparent cap in all the way.

→ Close the device (assembly tool: 674078¹⁹⁾).

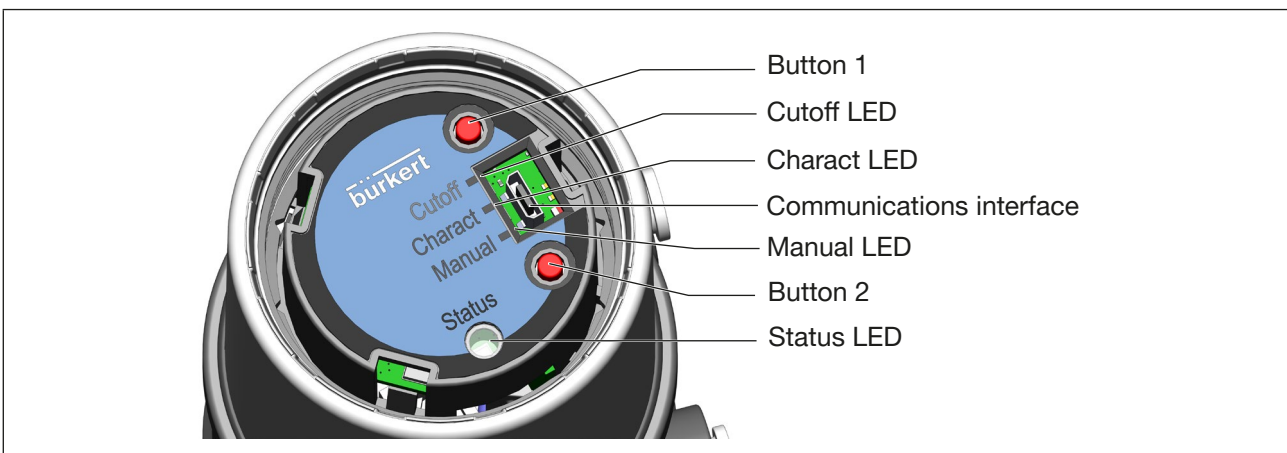

Figure 28: Starting X.TUNE

18) The X.TUNE can also be started via communications software.

19) The assembly tool (674078) is available from your Bürkert sales office

11.3 Setting with Bürkert Communicator

The Bürkert Communicator can be used to make all settings on the device.



The settings in the Bürkert Communicator can be found in the operating manual.

11.3.1 Connecting IO-Link device with Bürkert Communicator

Required components:

- Communications software: Bürkert Communicator for PC
- USB-büS interface set (see accessories)
- büS adapter for communications interface (see accessories)
- If necessary, a büS cable extension (see accessories)

ATTENTION

Breakage of the pneumatic connection pieces due to rotational impact.

- ▶ When opening or closing the device, do not press against the actuator, but against the basic housing.

→ Screw off the transparent cap by turning counterclockwise.

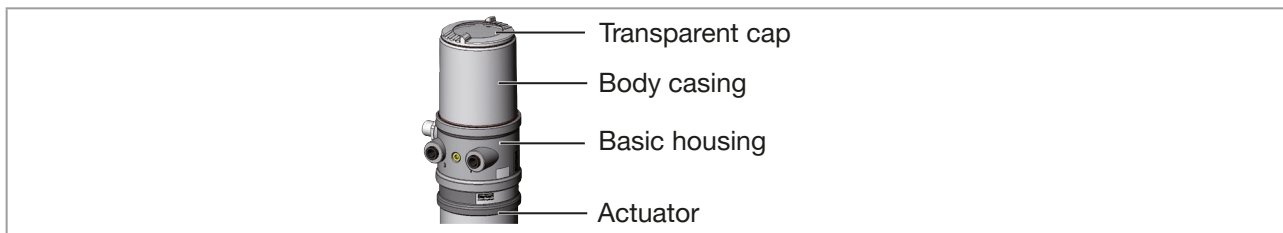

Figure 29: Open positioner

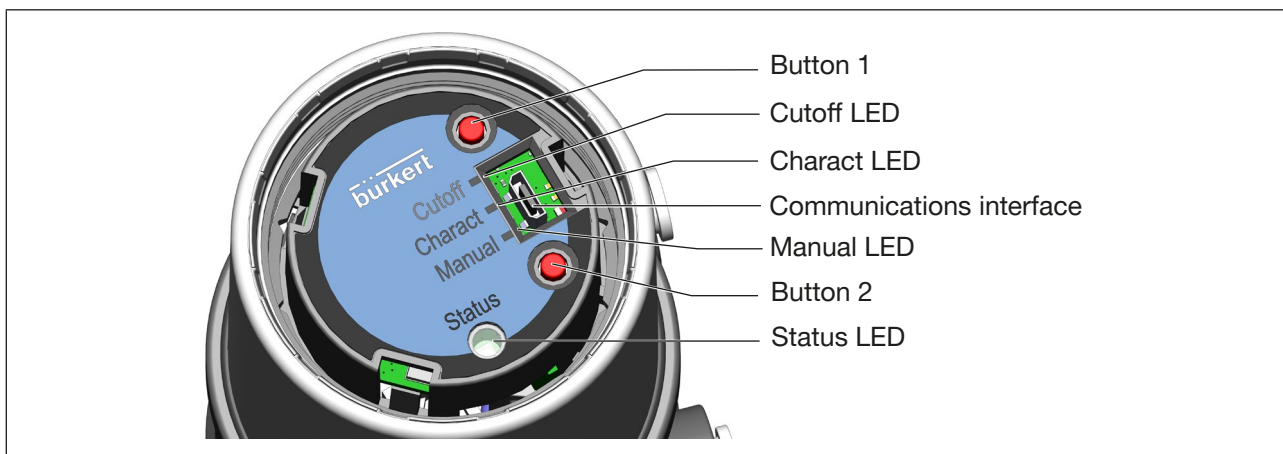

Figure 30: Communication interface

- Insert micro USB plug in communication interface.
- Establish connection to PC with USB-büS interface set.
- Starting Bürkert Communicator.
- Implementing settings.

11.3.2 Connecting bÜS device with Bürkert Communicator

Required components:

- Communications software: Bürkert Communicator for PC
- USB-bÜS interface set (see accessories)

→ Establish connection to PC with USB-bÜS interface set.

→ Starting Bürkert Communicator.

→ Implementing settings.

12 IO-LINK

12.1 Information, IO-Link

IO-Link is an internationally standardized IO technology (IEC 61131-9) to enable sensors and actuators to communicate.

IO-Link is a point-to-point communication with 3-wire connection technology for sensors and actuators and unshielded standard sensor cables.

To ensure clear communication, the IO-Link devices should not be parameterised simultaneously by the higher-level controller (PLC) via the IO-Link master and with the Bürkert Communicator (via the communication interface).

12.2 Technical specifications, IO-Link

IO-Link specifications	V1.1.2
Supply	via IO-Link (M12 x 1, 5-pin, A-coded)
Port Class	A or B
SIO mode	no
IODD file	see Internet
VendorID	0x0078, 120
DeviceID	see IODD file
ProductID	8696
Transmission speed	COM3 (230.4 kbit/s)
PD Input Bits	80
PD Output Bits	40
M-sequence Cap.	0x0D
Min. cycle time	5 ms
Data storage	Yes
Max. cable length	20 m

12.2.1 Configuration of the fieldbus

The required start-up files and the description of the process data and acyclic parameters are available on the Internet.



Download from:

www.burkert.com / Type 8696 / Software

13 BÜS

13.1 Information, büS

büS is a system bus developed by Bürkert with a communication protocol based on CANopen.

13.2 Configuration of the fieldbus

The required start-up files and the description of objects are available on the Internet.



Download from:

www.burkert.com / Type 8696 / Software

14 OPERATION AND FUNCTION

The positioner Type 8696 has different basic and additional functions which can be configured and parameterized via the DIP switches or the communications software.

14.1 Basic functions

The following basic functions can be activated via the buttons.

The parameter settings for the sealing function (CUTOFF) and characteristic correction (CHARACT) are made with the communication software.

Function	Description	Button	LED is lit	LED is not lit
Sealing function <i>CUTOFF</i>	Sealing function for positioner	1	Cutoff LED (yellow) Sealing function on	Cutoff LED (yellow) Sealing function off
Characteristic correction <i>CHARACT</i>	Selection of the Transfer Characteristic between Input Signal and Stroke (Correction Characteristic)	2	Charact LED (green) Correction characteristic	Charact LED (green) Linear characteristic
Automatic calibration of the position controller <i>X.TUNE</i>	Automatic adjustment of the positioner to the relevant operating conditions	1 ²⁰⁾	Status LED orange X.TUNE function running	
Reset to factory settings <i>RESET</i>	Reset to factory settings	1 and 2 simultaneously ²¹⁾	Manual LED, Charact LED and Cutoff LED flash at 10 Hz	

Table 26: Basic functions

ATTENTION!

Breakage of the pneumatic connection pieces due to rotational impact.

- ▶ When unscrewing and screwing in the transparent cap, do not hold the actuator of the process valve but the basic housing.

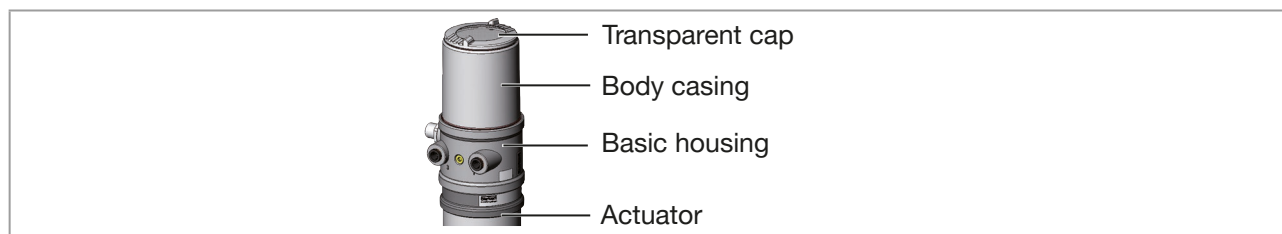

Figure 31: Open positioner

→ Screw off the transparent cap of the positioner to operate the buttons.

20) Press 5 s to start the X.TUNE function.

21) Press > 30 s to start

ATTENTION!

Damage or malfunction due to penetration of dirt and humidity.

- ▶ To observe degree of protection IP65 / IP67, screw the transparent cap in all the way.

→ Close the device (assembly tool: 674078²²⁾).

The following basic function can be changed via the communications software only.

Function	Description	Factory setting
Standard signal ²³⁾ <i>INPUT</i>	Entry of the standard signal input for the set-point value	4 – 20 mA, 4-wire
Reversal of the effective direction set-point value <i>DIR.CMD</i>	Effective direction between input signal and set-point position	OFF (fall)

Table 27: Basic functions

The *INPUT*, *CUTOFF*, *CHARACT* and *DIR.CMD* functions can be parameterized via the communications software.

The *X.TUNE* and *RESET* functions can also be started with the communication software.

MAN 1000417068 EN Version: B Status: RL (released | freigegeben) printed: 24.04.2026

22) The assembly tool (674078) is available from your Bürkert sales office.

23) Only variant without fieldbus communication.

14.1.1 **DIR.CMD -** **Reversal of the effective direction of the positioner set-point value**

You can use this function to adjust the effective direction between the input signal (INPUT) and the nominal position of the actuator.

Factory setting: OFF (ascending)

Position	Function
ON	Reversal of the effective direction of the set-point value (<i>DIR.CMD</i>) (set-point value 20 – 4 mA corresponds to position 0 – 100 %), fall
OFF	Normal effective direction of the set-point value (set-point value 4 – 20 mA corresponds to position 0 – 100 %), rise

Table 28: *Effective direction*

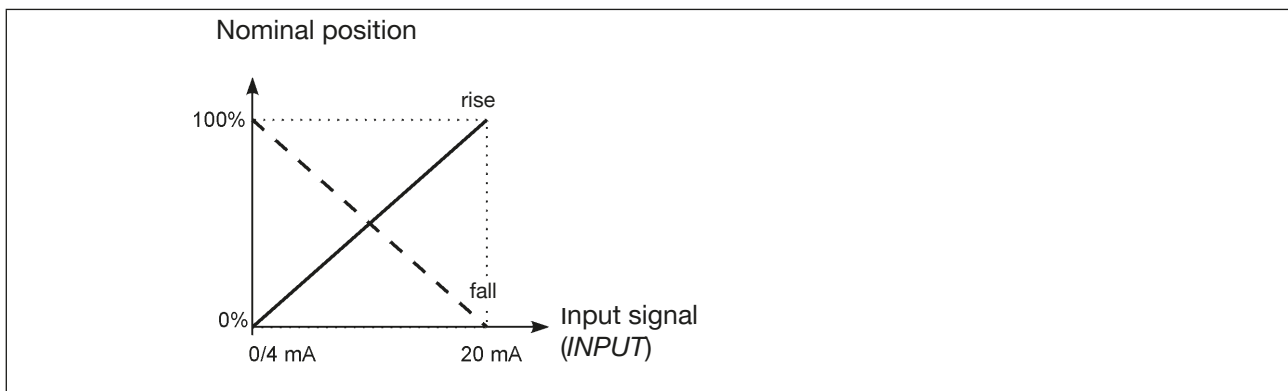

Figure 32: *DIR.CMD graph*

14.1.2 CUTOFF - Sealing function for the positioner

This function causes the valve to be sealed outside the control range.
Control mode resumes at a hysteresis of 1%.

Factory setting: OFF (no sealing function)

Position	Function
ON	Sealing function active. The valve completely closes below 2 % ²⁴⁾ and opens above 98 % of the set-point value (<i>CUTOFF</i>)
OFF	No sealing function

Table 29: Sealing function

The communications software can be used to change the limits for the position set-point value as a percentage.

! Activation in the device has priority over the communications software, i.e. settings of the sealing function (*CUTOFF*) which are modified via the communications software are only active if cutoff LED in the positioner lights up yellow.

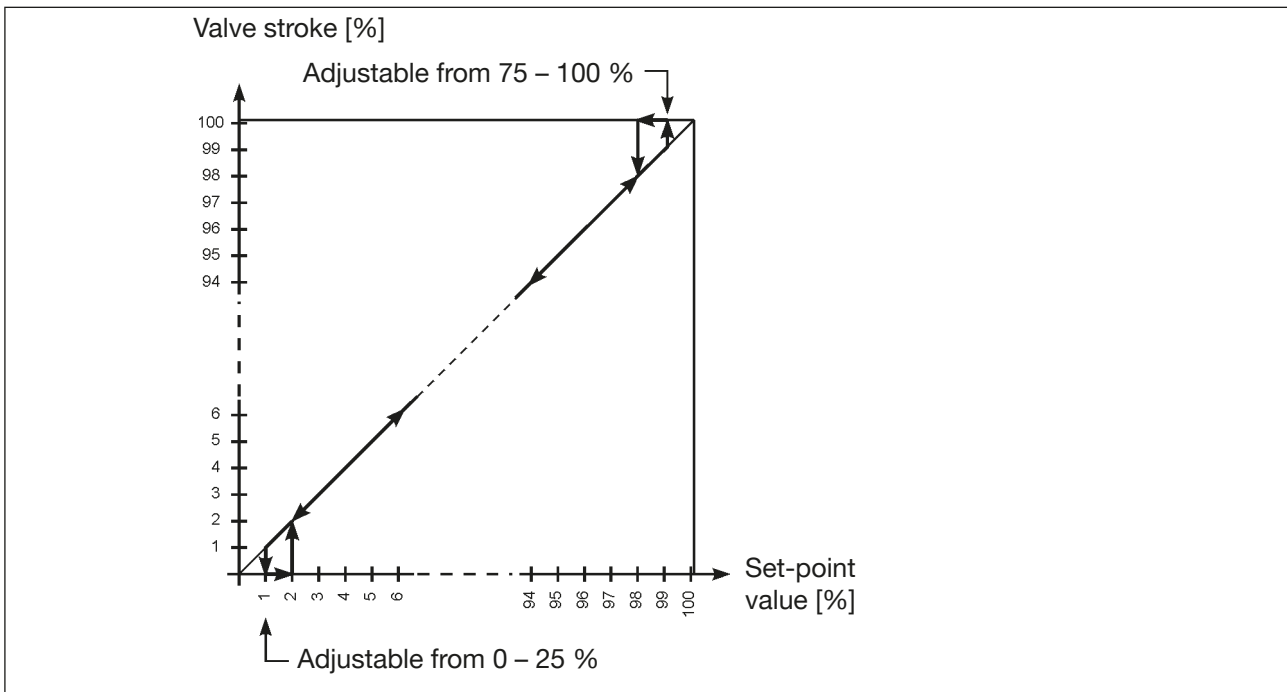

Figure 33: CUTOFF graph

24) Factory setting can be changed via communications software.

14.1.3 **CHARACT** - Characteristic correction between input signal (position set-point value) and stroke

Characteristic (customer-specific characteristic)

This function can be used to activate a transfer characteristic with respect to set-point value (set-point position) and valve stroke for correction of the flow-rate or operating characteristic.



The transfer characteristic can be changed via the communications software only.

Factory setting: OFF (linear)

Position	Function
ON	Correction characteristic for adjustment of the operating characteristic (linearization of the process characteristic <i>CHARACT</i>) ²⁵⁾
OFF	Linear characteristic

Table 30: Characteristic correction



Activation in the device has priority over the communications software, i.e. settings of the characteristic correction (*CHARACT*) which are modified via the communications software are only active if Charact LED in the positioner lights up green.

Characteristics which can be selected via the communications software:

Characteristic	Description
linear	Linear characteristic
1 : 25	Equal percentage characteristic 1 : 25
1 : 33	Equal percentage characteristic 1 : 33
1 : 50	Equal percentage characteristic 1 : 50
25 : 1	Inversely equal percentage characteristic 25 : 1
33 : 1	Inversely equal percentage characteristic 33 : 1
55 : 1	Inversely equal percentage characteristic 55 : 1
FREE	User-defined characteristic, freely programmable via nodes

Table 31: Selection of characteristics

²⁵⁾ The characteristic type can be changed via the communications software only.

The flow characteristic $k_v = f(s)$ indicates the flow-rate of a valve, expressed by the value k_v as a function of the stroke s of the actuator spindle. It is determined by the design of the valve seat and the seat seal. In general two types of flow characteristics are implemented, the linear and the equal percentage.

In the case of linear characteristics, equal k_v value changes dk_v are assigned to equal stroke changes ds .

$$(dk_v = n_{lin} \cdot ds).$$

In the case of an equal percentage characteristic, an equal percentage change of the k_v value corresponds to a stroke change ds .

$$(dk_v/k_v = n_{eqprct} \cdot ds).$$

The operating characteristic $Q = f(s)$ specifies the correlation between the volumetric flow Q in the installed valve and the stroke s . This characteristic has the properties of the pipelines, pumps and consumers. It therefore exhibits a form which differs from the flow characteristic.

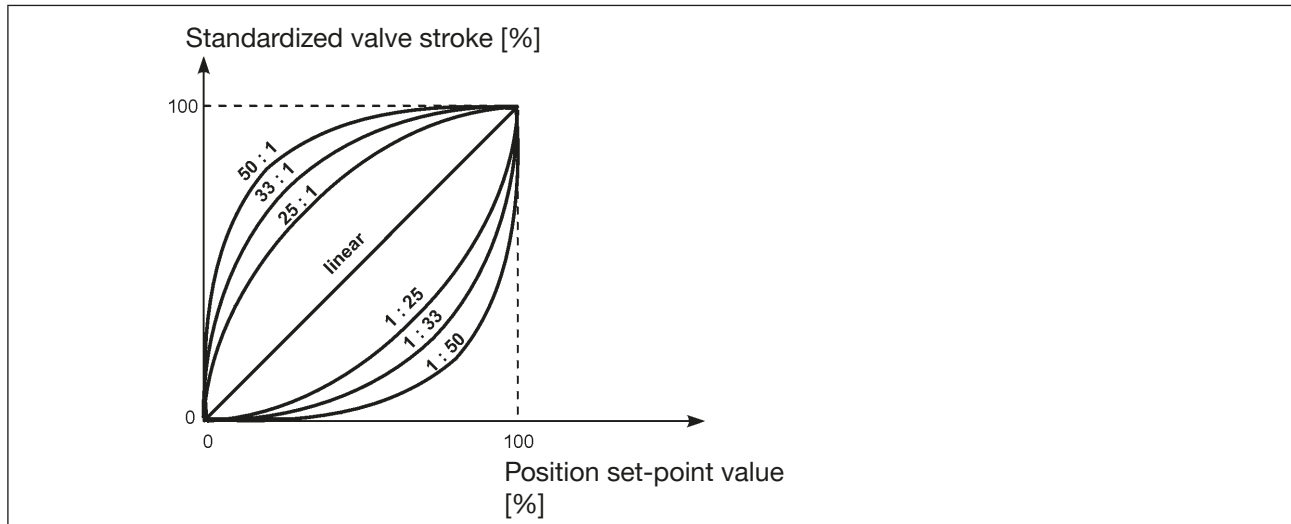

Fig. 34: Characteristic

In the case of control tasks for closed-loop control systems it is usually particular demands which are placed on the course of the operating characteristic, e.g. linearity. For this reason it is occasionally necessary to correct the course of the operating characteristic in a suitable way. For this purpose the positioner features a transfer element which implements different characteristics. These are used to correct the operating characteristic.

Equal percentage characteristics 1:25, 1:33, 1:50, 25:1, 33:1, and 50:1 as well as a linear characteristic can be set. A characteristic can be freely programmed using nodes.

Entering the freely programmable characteristic

The characteristic is defined by 21 nodes distributed uniformly over the position set-point values ranging from 0 – 100 %. They are spaced at intervals of 5 %. A freely selectable stroke (adjustment range 0 – 100 %) is assigned to each node. The difference between the stroke values of two adjacent nodes must not be greater than 20%.

Example of a programmed characteristic

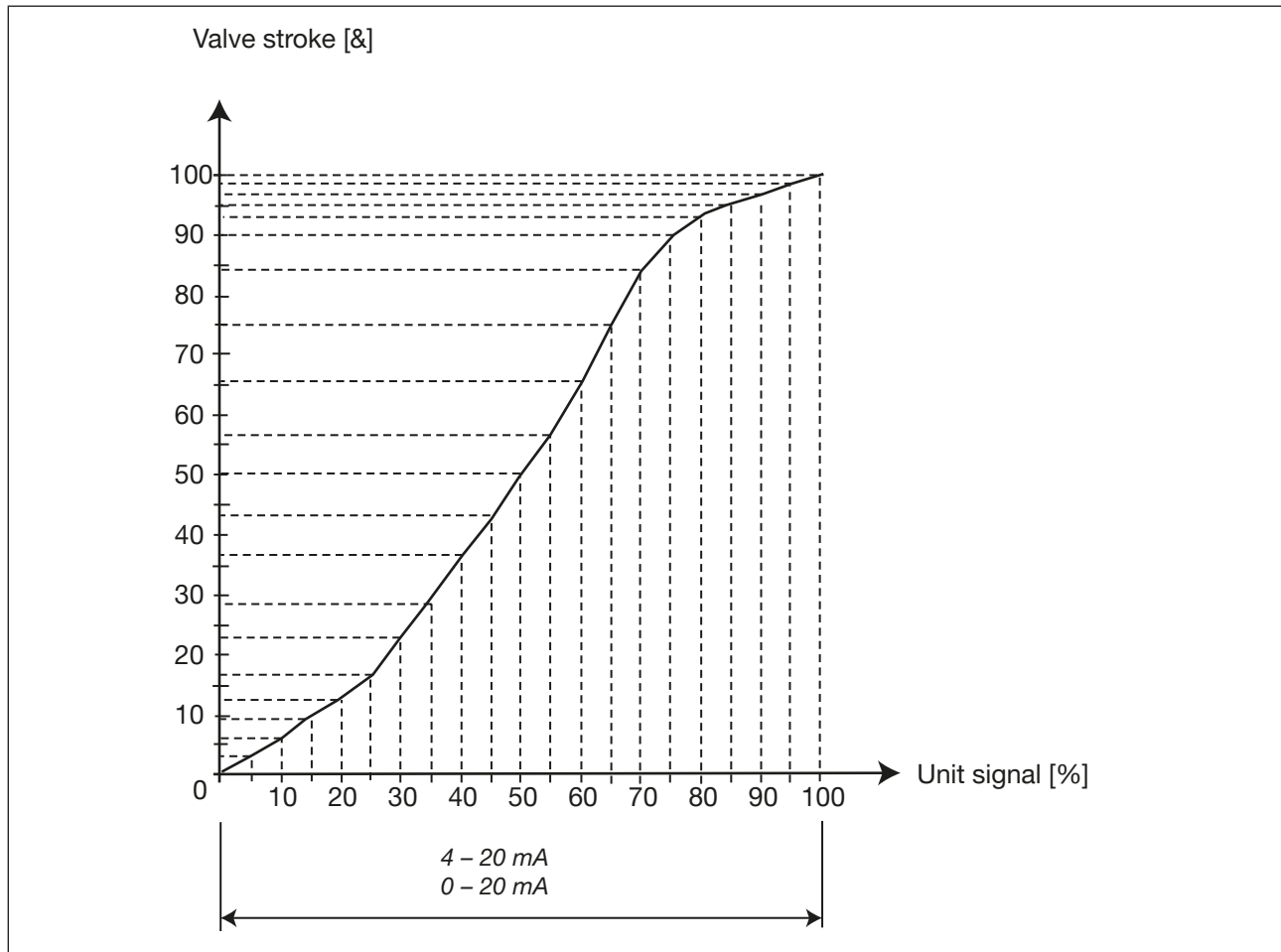

Fig. 35: Example of a programmed characteristic

14.1.4 INPUT - Enter the standard signal (only variant without fieldbus communication)

Under this menu option, enter the unit signal used for the set-point value.

Factory setting: 4 – 20 mA, 4-wire

Further settings: 4 – 20 mA, 3-wire
0 – 20 mA, 4-wire
0 – 20 mA, 3-wire

14.1.5 **RESET - Reset to factory settings**

This function can be used to reset the positioner to the factory settings.

14.1.6 **X.TUNE - Automatic adjustment of the positioner to the relevant operating conditions**



The *X.TUNE* function must be run for a function check of the positioner to adjust to specific local features.



WARNING!

While the *X.TUNE* function is running, the valve automatically moves from its current position.

- ▶ Never run *X.TUNE* while a process is running.
- ▶ Take appropriate measures to prevent the system / positioner from being unintentionally actuated.

ATTENTION!

Avoid maladjustment of the controller due to an incorrect compressed air supply or applied operating medium pressure.

- ▶ Run *X.TUNE* **whenever** the compressed air supply (= pneumatic auxiliary energy) is available during subsequent operation.
- ▶ Run the *X.TUNE* function preferably **without** operating medium pressure to exclude interference caused by flow forces.



To run *X.TUNE*, the positioner must be in the **AUTOMATIC** operating state (Manual LED is not lit).

→ Select **Automatic calibration of the position controller**.

→ Start *X.TUNE*. To do this, click **Next**.

The progress of *X.TUNE* is shown in the communication software.

When the automatic adjustment completes, a message appears.

The changes are automatically transferred to the positioner's memory (EEPROM) after the *X.TUNE* function is successful.

14.2 Auxiliary functions

The following additional functions can be configured and parameterized via the communications software:

Function	Description
Reversal of the effective direction of the actuator <i>DIR.ACT</i>	Assignment of the aeration status of the actuator chamber to the actual position
Signal split range <i>SPLTRNG</i>	Signal split range; input signal as a % for which the valve runs through the entire stroke range.
Stroke limit <i>X.LIMIT</i>	Limit the mechanical stroke range
Limit actuating time <i>X.TIME</i>	Limit the control speed
Control parameters <i>X.CONTROL</i>	Parameterize the position controller
Safety position <i>SAFEPOS</i>	Input the safety position
Cable break detection* <i>SIG.ERROR</i>	Configuration of signal level fault detection
Digital input* <i>BINARY.IN</i>	Activation of the digital input
Analog output* <i>OUTPUT</i>	Configuration of the outputs (only with auxiliary board for analogue feedback signal or digital outputs)

Table 32: Auxiliary functions

* Only for variant without fieldbus communication

14.2.1 *DIR.ACT* - Reversal of the effective direction of the actuator

Use this function to set the effective direction between the aeration state of the actuator and the actual position.

Factory setting: Off (rise)

Rise: Direct effective direction (deaerated → 0 %; aerated 100 %)

Case: Inverse effective direction (deaerated → 100 %; aerated 0 %)

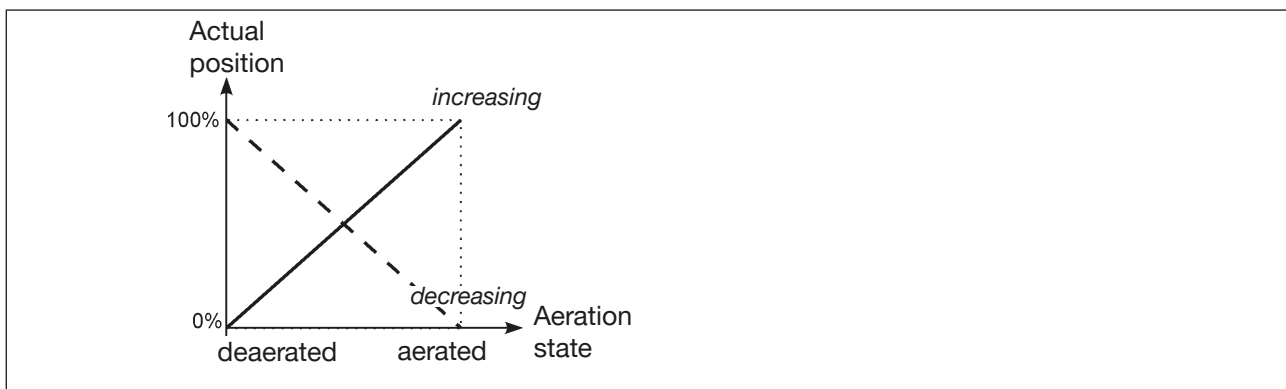

Figure 36: *DIR.ACT* graph

14.2.2 *SPLTRNG* - Signal split range

Minimum and maximum values of the input signal as a % for which the valve runs through the entire stroke range.

Factory setting: Lower signal range split = 0 %; Upper signal range split = 100 %

Lower value split range: Input the minimum value of the input signal as a %
Adjustment range: 0 – 75 %

Upper value split range: Input the maximum value of the input signal as a %
Adjustment range: 25 – 100 %

Use this function to limit the position set-point value range of the positioner by specifying a minimum and a maximum value. This makes it possible to divide a unit signal range that is used (4 – 20 mA, 0 – 20 mA) into several positioners (without or with overlapping). This allows several valves to be used alternately or, in the case of overlapping set-point value ranges, simultaneously as actuators.

To split a unit signal range into two set-point value ranges:

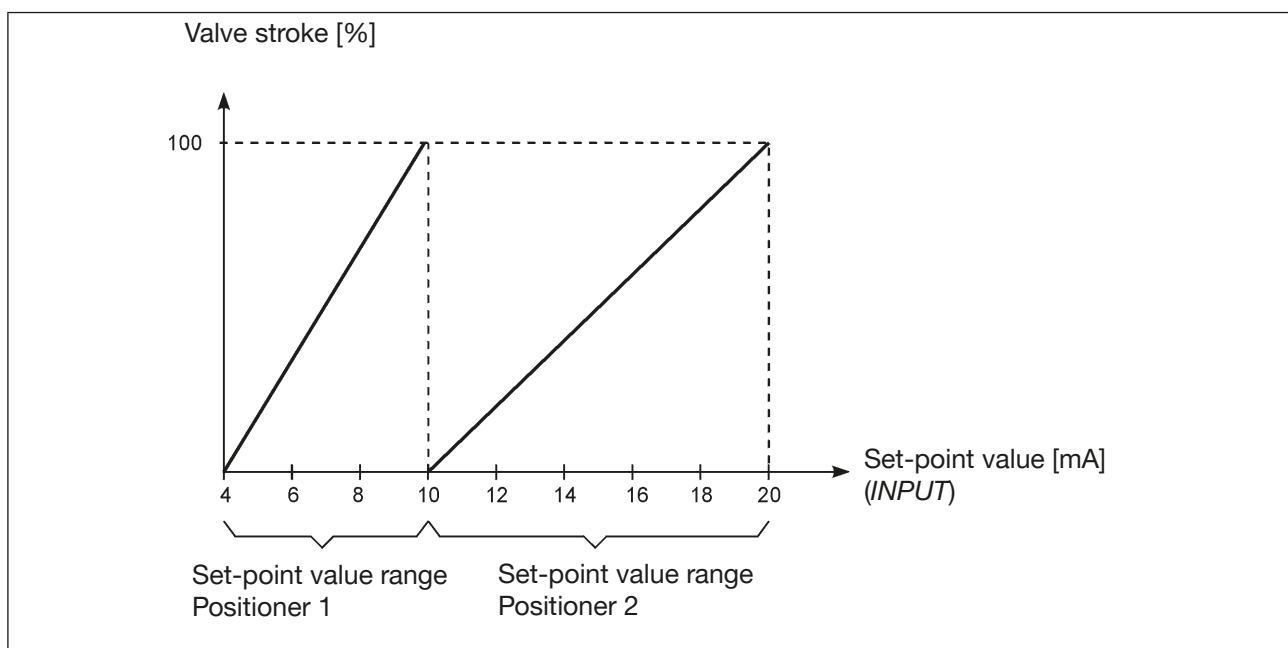

Figure 37: *SPLTRNG* graph

14.2.3 X.LIMIT - Stroke limit

This function limits the (physical) stroke to specified % values (lower and upper). In doing so, the stroke range of the limited stroke is set equal to 100 %. If the limited stroke range is left during operation, negative actual positions or actual positions greater than 100 % are shown.

Factory setting: Lower position limit = 0 %, upper position limit = 100 %

Adjustment ranges:

Stroke limit minimum: 0 – 50 % of the entire stroke

Stroke limit maximum: 50 – 100 % of the entire stroke

The minimum distance between the upper and lower stroke limit is 50 %. Therefore if one value is entered with a minimum distance of < 50 % the other value is adjusted automatically.

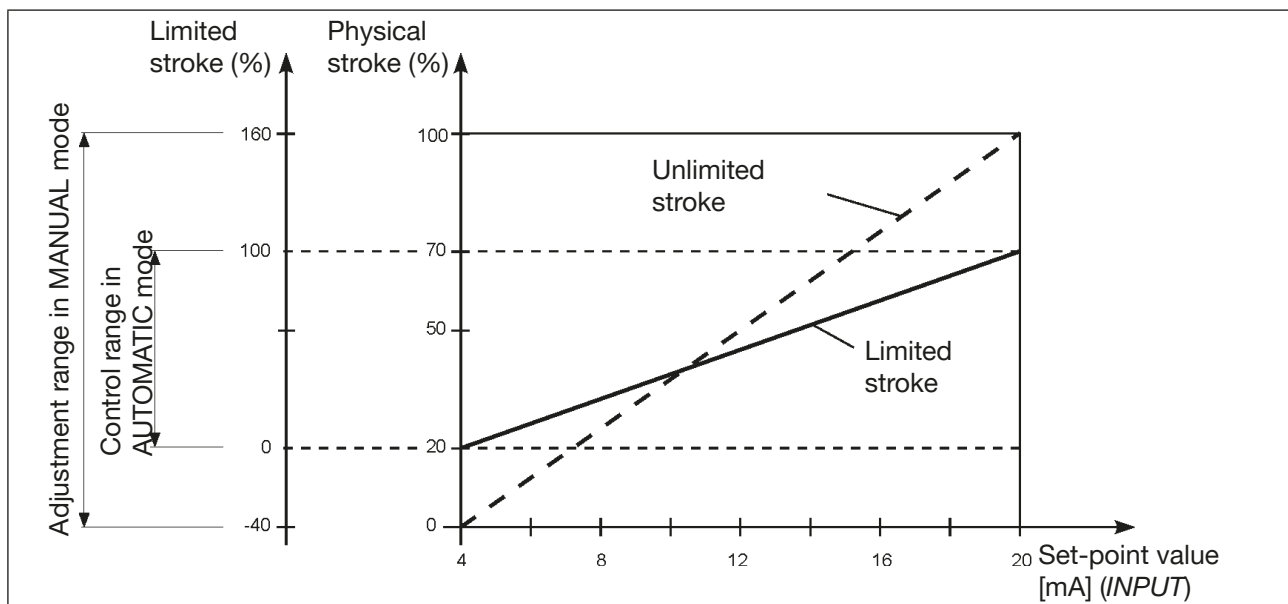

Figure 38: X.LIMIT graph

14.2.4 X.TIME - Limit actuating time

Use this function to specify the opening and closing times for the entire stroke and thereby limit control speeds.

! When the *X.TIME* function is running, the minimum opening and closing time for the entire stroke is automatically entered for Open and Close. Therefore, movement can be at maximum speed.

Factory setting: values determined at the factory by the *X.TIME* function

If the control speed will be limited, values can be input for Open and Close which are between the minimum values determined by the *X.TIME* and 60 seconds.

Opening time: Opening time for entire stroke (in seconds)
Adjustment range: 1 – 60 seconds

Closing time: Closing time for entire stroke (in seconds)
Adjustment range: 1 – 60 seconds

Effect of limiting the opening speed when there is a jump in the set-point value

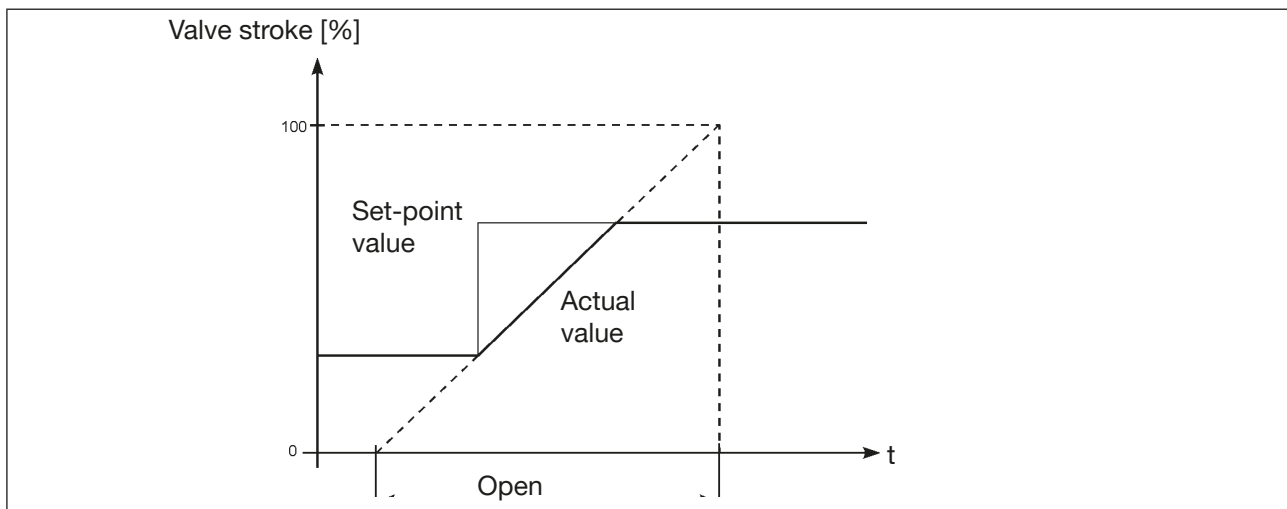

Figure 39: *X.TIME* graph

14.2.5 X.CONTROL - Control parameters of the positioner

Use this function to set the parameters for the positioner (dead band and amplification factors (kp)).

Deadband: Insensitivity range of the positioner

Entry for the deadband as a % in reference to the scaled stroke range;
i.e. stroke limit maximum - stroke limit minimum (see auxiliary function stroke limit (X.LIMIT)).

This function causes the controller to respond only beginning at a specific control difference. This function saves wear on the solenoid valves in the positioner and the pneumatic actuator.



If the auxiliary function control parameters (X.CONTROL) is in the main menu while X.TUNE (Autotune of the positioner) is running, the deadband is determined automatically depending on the friction behavior of the actuator. The value determined in this way is an approximate value. You can re-adjust it manually.

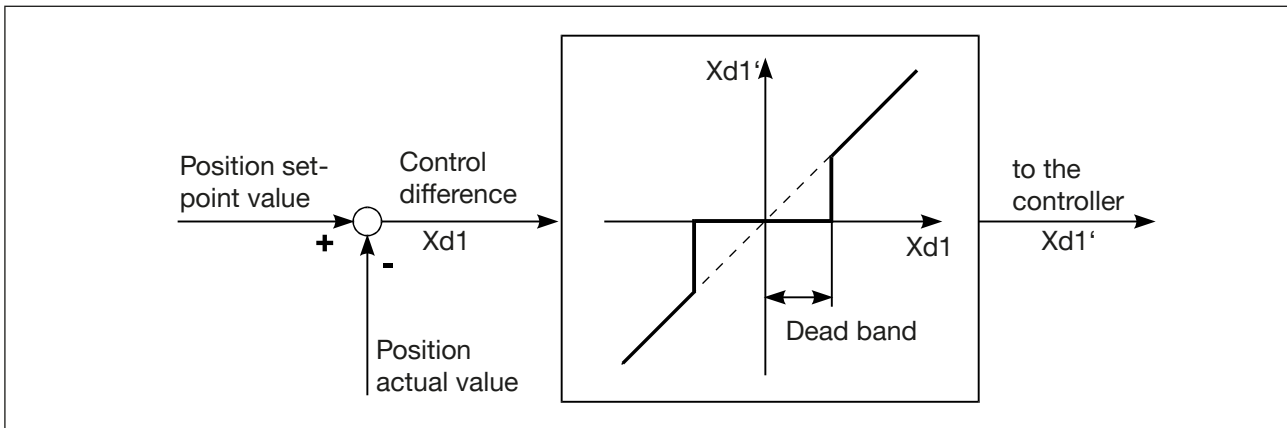

Figure 40: X.CONTROL graph

Open/close amplification factor: Parameters for the positioner

Open amplification factor: Amplification factor of the positioner (for closing the valve)

Close amplification factor: Amplification factor of the positioner (for opening the valve)

14.2.6 SAFPOS - Definition of the safe position

This function specifies the actuator safety position which is approached at defined signals.



The set safety position is only approached if a error occurs.
If the mechanical stroke range is limited with the stroke limit function (X.LIMIT), only safety positions within these limits can be approached.
This function is executed in AUTOMATIC operating state only.

14.2.7 **SIG.ERROR** - Configuration of cable break detection (only for variant without fieldbus communication)

The cable break detection function (*SIG.ERROR*) is used to detect a fault on the input signal.



Cable break detection can be selected for a 4 – 20 mA signal only:
Fault if input signal ≤ 3.5 mA (± 0.5 % of final value, hysteresis 0.5 % of final value)

If 0 – 20 mA is selected, cable break detection cannot be selected.

A signal error is indicated on the device by the LED 1 for activated cable break detection (error or out of specification).

Safety position for activated cable break detection:

Active safe position function (*SAFEPOS*)

If a fault is detected, the actuator moves to the position set under safe position function.

Inactive safe position function (*SAFEPOS*)

If a fault is detected, the actuator moves to the end position which it would assume in the isolated state.

14.2.8 **BINARY.IN** (variant) - Configuration of the digital input (only for variant without fieldbus communication)

The following settings can be implemented:

- Approach the safety position
- Starting the function *X.TUNE*

Safety position

Digital input = 1 → Approach the safety position.

Active safety position function (*SAFEPOS*)

The actuator moves to the position set under safe position function.

Inactive safety position function (*SAFEPOS*)

The actuator moves to the end position which it would assume in the isolated state.

Starting the function *X.TUNE*

Digital input = 1 → Starting *X.TUNE*.

14.2.9 OUTPUT (variant) - Configuration of the analog output (only for variant without fieldbus communication)

The function analog output (OUTPUT) only appears in the selection of functions if the positioner has an analog output (variant) or if no parameters have been read in yet.

The analog output can be used for feedback of the current position or of the set-point value to the control center.

Function	Position (POS) Set-point value (CMD)	Output of the current position Output of the set-point value
Standard signal	4 – 20 mA 0 – 20 mA	Selection of the standard signal

14.2.10 Setting the LED mode, device status

User level: installer

Factory setting: valve mode + warnings

Menu or function		Values or description
Device		
>	General settings	
>	Parameter	
>	Status LED	
	Mode	<input checked="" type="radio"/> NAMUR mode <input type="radio"/> Valve mode <input type="radio"/> Valve mode + Warnings <input type="radio"/> Fixed color <input type="radio"/> LED off

Setting the LED mode, device status:

→ Status LED

→ Mode

Possible selection:

- NAMUR mode
- Valve mode
- Valve mode + Warnings
- Fixed color
- LED off

→ Select mode.

The mode is set.

15 SAFETY END POSITIONS

15.1 Safety end positions after failure of the electrical or pneumatic auxiliary power

Actuator System	Designation	Safety end positions after failure of the auxiliary power	
		electrical	pneumatic
	single-acting control function A	down	not defined
	single-acting control function B	up	not defined

Table 33: Safety end positions

16 MAINTENANCE

The positioner Type 8696 is maintenance-free when operated according to the instructions in this manual.

17 DISASSEMBLY

17.1 Safety instructions

DANGER!

Risk of injury from high pressure in the equipment/device.

- ▶ Before working on equipment or device, switch off the pressure and deaerate/drain lines.

Risk of electric shock.

- ▶ Before working on equipment or device, switch off the power supply and secure to prevent reactivation.
- ▶ Observe applicable accident prevention and safety regulations for electrical equipment.

WARNING!

Risk of injury from improper disassembly.

- ▶ Disassembly may be carried out by authorized technicians only and with the appropriate tools.

Risk of injury from unintentional activation of the system and an uncontrolled restart.

- ▶ Secure system from unintentional activation.
- ▶ Following disassembly, ensure a controlled restart.

17.2 Disassembly the positioner

Procedure:

1. Pneumatic connection

DANGER!

Risk of injury from high pressure in the equipment/device.

- ▶ Before working on equipment or device, switch off the pressure and deaerate/drain lines.

→ Loosen the pneumatic connection.

2. Electrical connection



DANGER!

Risk of electric shock.

- ▶ Before working on equipment or device, switch off the power supply and secure to prevent reactivation.
- ▶ Observe applicable accident prevention and safety regulations for electrical equipment.

→ Loosen the circular plug-in connector.

3. Mechanical connection

→ Loosen the fastening screws.

→ Remove the positioner upwards.

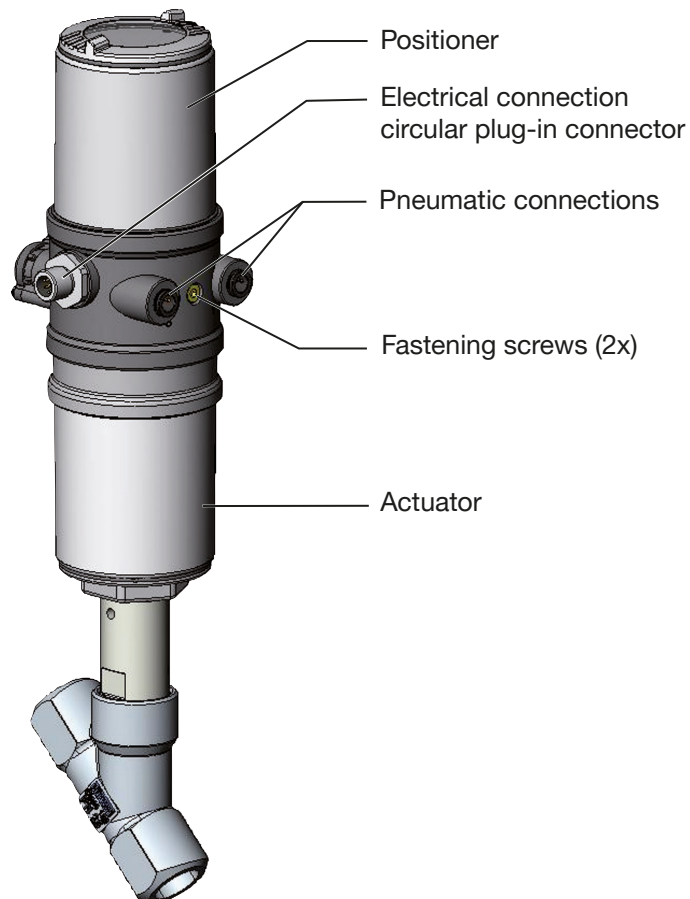

Figure 41: Disassembly the positioner

18 ACCESSORIES

Designation	Order no.
Communication software Bürkert Communicator	Information at country.burkert.com
Connection cable M12 x 1, 8-pole	919061
Wrench for opening/closing the transparent cap	647078

USB-büS interface set:	
USB-büS interface set (büS stick + 0.7 m cable with M12 plug)	772551
büS adapter for communication interface (M12 on büS service interface Micro-USB)	773254
	
büS cable extension (M12 pin to M12 socket), length 1 m	772404
büS cable extension (M12 pin to M12 socket), length 3 m	772405
büS cable extension (M12 pin to M12 socket), length 5 m	772406
büS cable extension (M12 pin to M12 socket), length 10 m	772407

Table 34: Accessories

18.1 Communications software

The PC operating program Bürkert Communicator is designed for communication with the devices from the Bürkert positioner family.

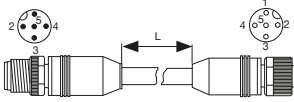

A detailed description and precise schedule of the procedure for the installation and operation of the software can be found in the associated documentation.

Download the software at: country.burkert.com.

19 TRANSPORTATION, STORAGE, DISPOSAL

ATTENTION

Damage in transit due to inadequately protected devices.

- ▶ Protect the device against moisture and dirt in shock-resistant packaging during transportation.
- ▶ Observe permitted storage temperature.

ATTENTION

Incorrect storage may damage the device.

- ▶ Store the device in a dry and dust-free location.
- ▶ Storage temperature: -20 to +65 °C

Environmentally friendly disposal



- ▶ Follow national regulations regarding disposal and the environment.
- ▶ Collect electrical and electronic devices separately and dispose of them as special waste.

Further information [country.burkert.com](https://www.country.burkert.com).

