

Technical Information

Thermocouples TH51, TH52 & TH56

General purpose MgO insulated thermocouples with connection head, extension lead wires or connectors for process and laboratory applications



Areas of application

Magnesium Oxide insulated thermocouples, commonly referred to as MgO thermocouples, are used in many process and laboratory applications. They have many desirable characteristics making thermocouples a good choice for general and special purpose applications.

The sensors can be used on:

- Heat exchangers
- Power & recovery areas
- Furnaces
- Dryers
- Flue gas
- Compressor stations
- Process reactors
- Metallurgical and Glass manufacturing

Head transmitters

Instead of directly wiring your temperature sensors to your control system, use transmitters to reduce wiring and maintenance costs while increasing measurement accuracy.

Your benefits

- One source shopping for temperature measurement solutions. World class transmitter with integrated sensor offering.
 - Remove and install straight out of the box!
- Improved galvanic isolation on most devices (2 kV)
- Simplified model structure: Competitively priced, offers great value. Easy to order and reorder. A single model number includes sensor and transmitter assembly for a complete point solution.
- All iTEMP® transmitters provide long term stability $\leq 0.05\%$ per year

Measurement range**Measuring range by type and size**

Upper Temperature Limits for Various Sheath Diameters °F (°C)							
Nominal Diameter			Thermocouple Type				
Sheath OD	Element wire Dia. (in)	Element wire Gauge	T	J	E	K	N
∅ 1/16"	0.010	30	500 °F (260 °C)	825 °F (440 °C)	950 °F (510 °C)	1690 °F (920 °C)	
∅ 1/8"	0.020	24	600 °F (315 °C)	970 °F (520 °C)	1200 °F (650 °C)	1960 °F (1070 °C)	
∅ 3/16"	0.029	21	700 °F (370 °C)	1150 °F (620 °C)	1350 °F (730 °C)	2100 °F (1150 °C)	
∅ ¼"	0.039	19		1330 °F (720 °C)	1510 °F (820 °C)		
∅ 3/8"	0.060	15					
Maximum Element Temperature Range Limits			-454 to 752 °F (-270 to +400 °C)	-346 to 2192 °F (-210 to +1200 °C)	-454 to 1832 °F (-270 to +1000 °C)	-454 to 2500 °F (-270 to +1372 °C)	-454 to 2372 °F (-270 to +1300 °C)

**Note!**

These values are valid for single and duplex thermocouples. The temperature limits given are intended only as a guide to the user and should not be taken as absolute values or as guarantees of satisfactory life or performance. These types and sizes are sometimes used at temperatures above the given limits, but usually at the expense of stability or life or both. In other instances, it may be necessary to reduce the above limits in order to achieve adequate service.

**Note!**

Duplex versions (2 elements) of Type N with 1/16", 3/16" and 3/8" sheath diameter are not available. Thermocouples with 316 SS sheath are rated for a maximum temperature of 1700 °F (927 °C).

Electronics

Family of temperature transmitters

Thermocouple assemblies with iTEMP® transmitters are an installation ready solution to improve the functionality of temperature measurement by increasing accuracy and reliability when compared to direct wired sensors. Overall installation costs are lower than with direct wired sensors, since an inexpensive pair of signal (4 to 20 mA) wires can be run over long distances.

PC programmable device TMT 181

PC programmable devices offer you extreme flexibility and help control costs with the ability to stock one device and program it for your needs. Regardless of your choice of output, all iTEMP® transmitters can be configured quickly and easily with a PC. To help you with this task, Endress+Hauser offers free software ReadWin® 2000 which can be downloaded from our website. Go to www.readwin2000.com to download ReadWin® 2000 today.

HART® device TMT 182

HART® communication is all about easy, reliable data access and getting better information more inexpensively. iTEMP® transmitters integrate seamlessly into your existing control system and provide painless access to preventative diagnostic information. Configuration with a DXR 275 or 375 hand-held or a PC with configuration program (Commuwin II, ReadWin® 2000) or configure with AMS or PDM.

Field transmitter TMT 162

Field transmitter with HART® communication and blue backlit display. Can be read easily from a distance, in sunlight and at night. Large measurement value, bargraph and fault indication displayed. Benefits are: dual sensor input, highest reliability in harsh industrial environments, mathematic functions, thermometer drift monitoring and sensor back-up functionality, corrosion detection.

Performance characteristics

Response time

63% response time per ASTM E839

Junction Style	Ø 1/16"	Ø 1/8"	Ø 3/16"	Ø 1/4"	Ø 3/8"
Grounded	0.3	0.6	0.9	1.3	3.5
Ungrounded	0.4	1.6	2.4	2.9	7.2



Note!
Response Time for the sensor assembly without transmitter

Maximum measured error

Thermocouples corresponding to ASTM E-230.

Type	Temperature Range		Standard Tolerance (IEC Class 2)	Special Tolerance (IEC Class 1)
	[°C]	[°F]	[°C] (whichever is greater)	[°C] (whichever is greater)
E	0 to 870	32 to 1600	±1.7 or ±0.5%	±1 or ±0.4%
J	0 to 760	32 to 1400	±2.2 or ±0.75%	±1.1 or ±0.4%
K	0 to 1260	32 to 2300	±2.2 or ±0.75%	±1.1 or ±0.4%
T	0 to 370	32 to 700	±1 or ±0.75%	±0.5 or ±0.4%
N	0 to 1260	32 to 2300	±2.2 or ±0.75%	±1.1 or ±0.4%



Note!
For measurement errors in °F, calculate using equation above in °C, then multiply the outcome by 1.8.

Measurement accuracy transmitter

Transmitter

TMT 181 multifunctional PCP	TMT 182 HART®	TMT 162 HART® Field Transmitter
0.36 °F (0.2 °C) or 0.08% ¹	0.36 °F (0.2 °C) or 0.08% ¹	≤ 0.19 °F (0.105 °C)

1) % is related to the adjusted measurement range (the larger value applies)

Transmitter long-term stability

≤ 0.18 °F / year (≤ 0.1 °C / year) or ≤ 0.05% / year
Data under reference conditions; % is related to the set span. The larger value applies.

Insulation resistance

Insulation resistance for MgO insulated thermocouples with ungrounded hot junction between terminals and probe sheath, test voltage 500 Vdc.

- 1,000 MΩ at 77 °F (25 °C)

These values for insulation resistance apply also between each thermocouple wire at single and duplex constructions with ungrounded hot junction.

Galvanic isolation

Galvanic isolation of Endress+Hauser iTEMP® transmitters (input/output)

Transmitter type	Sensor
TMT 181 PCP	$\hat{U} = 3.75 \text{ kV AC}$
TMT 182 HART®	$U = 2 \text{ kV AC}$
TMT 162 HART® Field transmitter	$U = 2 \text{ kV AC}$

In applications where fast response time is needed, grounded thermocouples are recommended. This thermocouple design may cause a ground loop. This can be avoided by using iTEMP transmitters with high galvanic isolation.

Wiring

Wiring diagrams

Type of sensor connection TH51

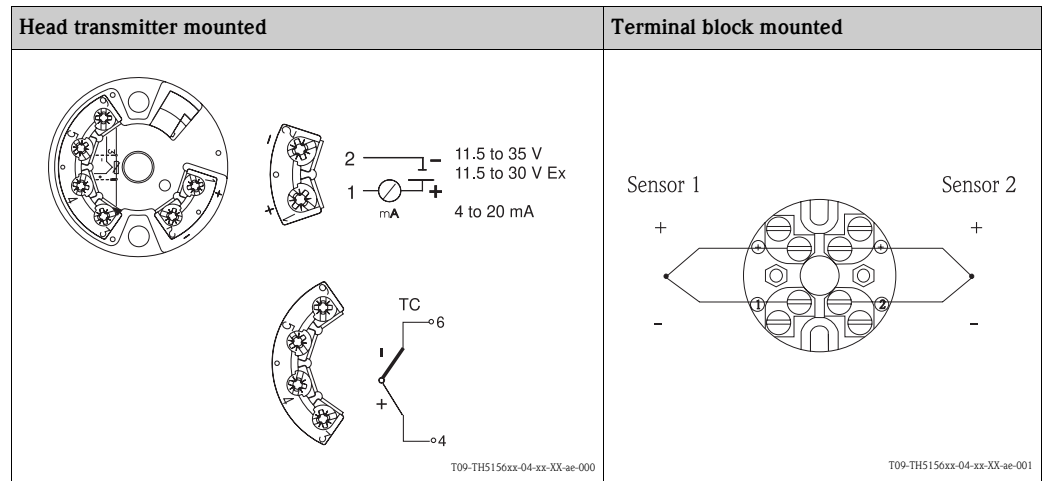

Note!
TH52 is available only with conductor external lead wires, DIN rail transmitters (TMT 121 PCP / TMT 122 HART®) are available, see 'Documentation'.



Note!
The blocks and transmitters are shown as they sit inside the heads in reference to the conduit opening.

Wire specifications

TH51

Thermocouple grade, TFE insulated 20AWG, 7 strands with wire termination

TH52

All thermocouple extension wires are thermocouple grade.

Sheath OD	No of elements	Extension wire (gauge)
Ø 1/16"	1	24
	2	24
Ø 1/8"	1	20
	2	24
Ø 3/16"	1	20
	2	24
Ø ¼"	1	20
	2	20
Ø 3/8"	1	20
	2	20

Thermocouple wire types, Construction and Characteristics

Type	Single conductor		Duplex conductor		Max. continuous temperature	Notes
	Insulation	Impregnation	Insulation	Impregnation		
Fiberglass	Glass Braid 0.006"	Silicone modified resin	Glass braid 0.006"	Silicone modified resin	900 °F (482 °C)	Impregnation retained to 400 °F (204 °C)
Teflon	FEP extruded 0.008"	/	FEP extruded 0.010"	/	400 °F (204 °C)	



Note!
Flex armor is 0.272" nominal OD, 304SS 0.010" thick, square lock style.
TH52 is also available with connector, see section "Connector style".

Connector style

Type of connectors TH52 and TH56, standard and miniature plugs

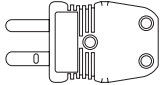
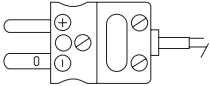
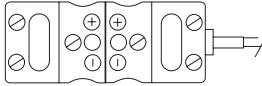
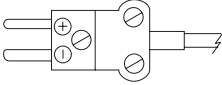
A = STANDARD	 <small>T09-TH5150xx-04-xx-XX-ae-009</small>	max. 350 °F TH52, all types J and K TH56, types J and K 3/16" and ¼" only
	 <small>T09-TH5150xx-04-xx-XX-ae-008</small>	max. 350 °F All Others!
B = STANDARD W/ FEMALE	 <small>T09-TH5150xx-04-xx-XX-ae-003</small>	max. 350 °F
C = MINI	 <small>T09-TH5150xx-04-xx-XX-ae-004</small>	max. 350 °F

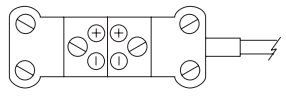
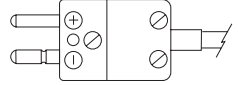
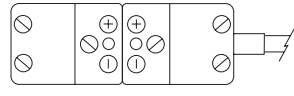
D = MINI W/ FEMALE	 T09-TH5156xx-04-xx-XX-ae-005	max. 350 °F
E = STANDARD (HIGH TEMP.)	 T09-TH5156xx-04-xx-XX-ae-006	max. 800 °F
G = STANDARD W/ FEMALE (HIGH TEMP.)	 T09-TH5156xx-04-xx-XX-ae-007	max. 800 °F
Y = SPECIAL		

Thermocouple color codes per ASTM E-230

T.C. Type	POS NEG	Material	MAGNETIC		Insulation		Plug & Jack ¹
			YES	NO	Single Conductor	Overall T.C. wire	
E	EP (+)	Nickel - 10% chromium		X	Purple	Brown	Purple
	EN (-)	Copper - 45% nickel (constantan)		X	Red		
J	JP (+)	Iron	X		White	Brown	Black
	JN (-)	Copper - 45% nickel (constantan)		X	Red		
K	KP (+)	Nickel - 10% chromium		X	Yellow	Brown	Yellow
	KN (-)	Nickel - 5% (aluminium, silicon) ²	X		Red		
T	TP (+)	Copper		X	Blue	Brown	Blue
	TN (-)	Copper - 45% nickel (constantan)		X	Red		
N	NP (+)	Nickel - 14% chromium - 1.5% silicon		X	Orange	Brown	Orange
	NN (-)	Nickel - 4.5% silicon - 0.1% magnesium		X	Red		

- 1) References for Plug & Jack Color Codes are based on ASTM E-1129 / E 1129M - 98, Standard Specification of Thermocouple connectors and ASTM E-1684, Standard Specification for Miniature Thermocouple Connectors.
- 2) Silicon, or aluminium and silicon, may be present in combination with other elements.

Installation conditions

Orientation No restrictions for installation orientation.

Installation instructions

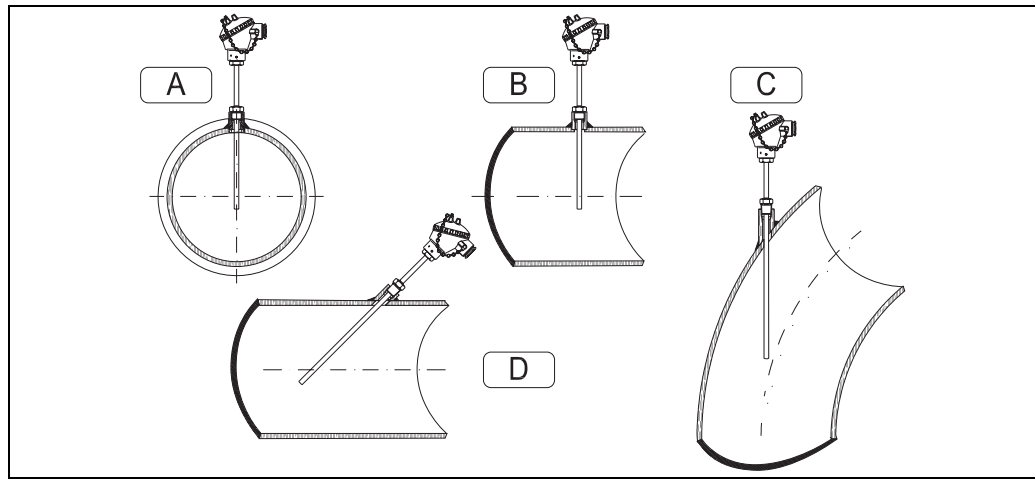

T09-TH1112xx-11-xx-xx-ae-000

Installation examples

A - B: In pipes of a small section the axis line of the duct must be reached and, if possible, slightly exceeded by the tip of the probe

C - D: Tilted installation

Insertion length

Minimum immersion length should be 10 times the OD of the sheath, nominal.

Environmental conditions

Ambient temperature

Housing without head-mounted transmitter

- Aluminum pressure die-cast housing -40 to 302 °F (-40 to 150 °C)
- Plastic housing -40 to 185 °F (-40 to 85 °C)

Housing with head-mounted transmitter

- -40 to 185 °F (-40 to 85 °C)

Shock and vibration resistance 4g / 2 to 150 Hz as per IEC 60 068-2-6

Process conditions

Process pressure limits

p/T load curve example according to Dittrich.

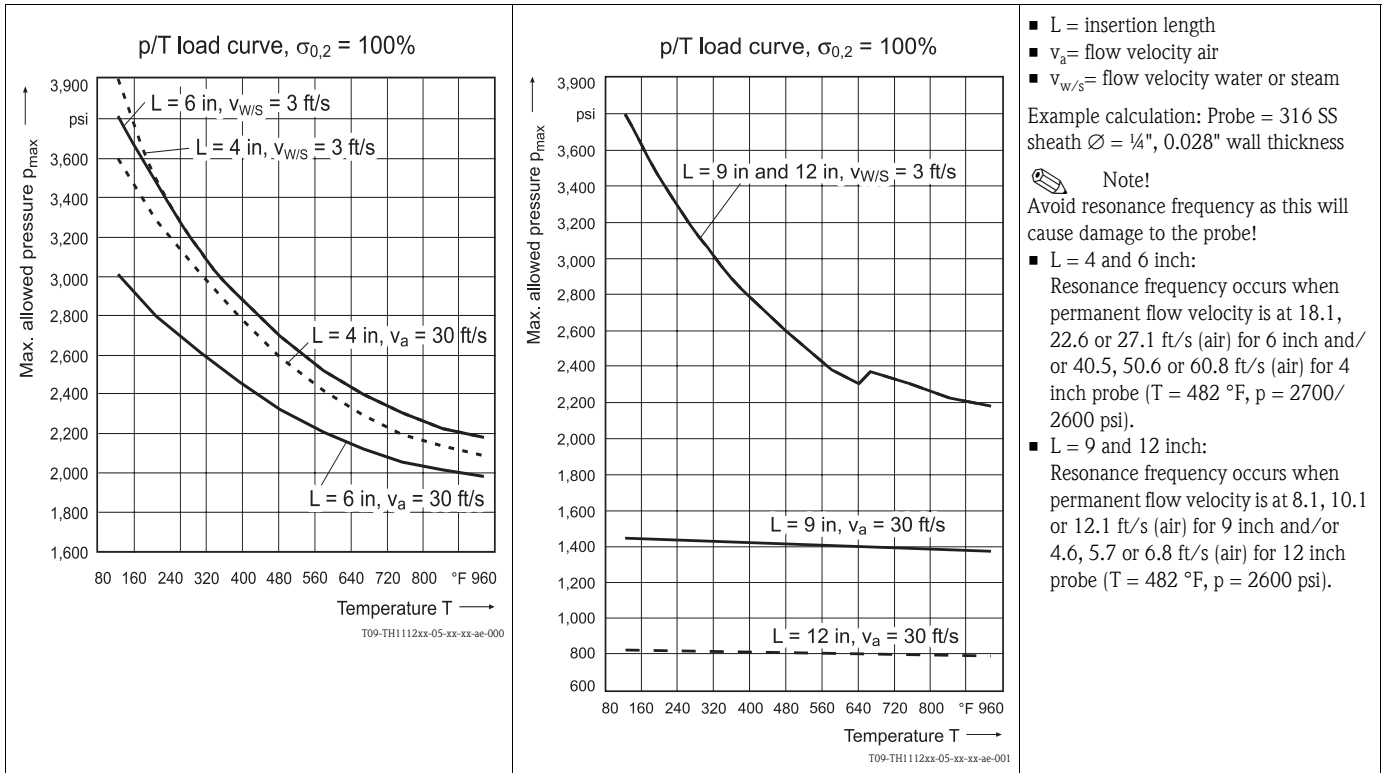

Note!

The calculation was done for pipes only, for MgO insulated thermocouples the values might be higher. In any case for different lengths, other materials, variation in sheath diameter or wall thicknesses, stress analysis is recommended. Failures are caused by forces imposed by static pressure, steady state flow, and vibration.

Max. allowable process pressure (PSIG) for instrumentation with one time adjustable compression fittings.

Temperature		1/8" NPT & 1/4" NPT compression fitting				
°F	°C	Sheath $\varnothing = 1/16"$	Sheath $\varnothing = 1/8"$	Sheath $\varnothing = 3/16"$	Sheath $\varnothing = 1/4"$	Sheath $\varnothing = 3/8"$ ¹⁾
-20 to 300	-28 to 204	3300	2850	3150	3350	3900
400	204	3200	2750	3050	3250	3800
500	260	3000	2550	2850	3000	3500
600	316	2800	2400	2700	2850	3300
700	371	2700	2350	2600	2750	3200
800	427	2650	2300	2550	2650	3100
900	482	2600	2200	2450	2600	3050
1000	538	2400	2100	2300	2450	2850

1) Not available with compression fittings 1/8" NPT



Note!

Re-adjustable compression fittings are not intended to be used for pressure retaining applications and should only be used for the mechanical holding of sensors.

Mechanical construction

Design, dimensions

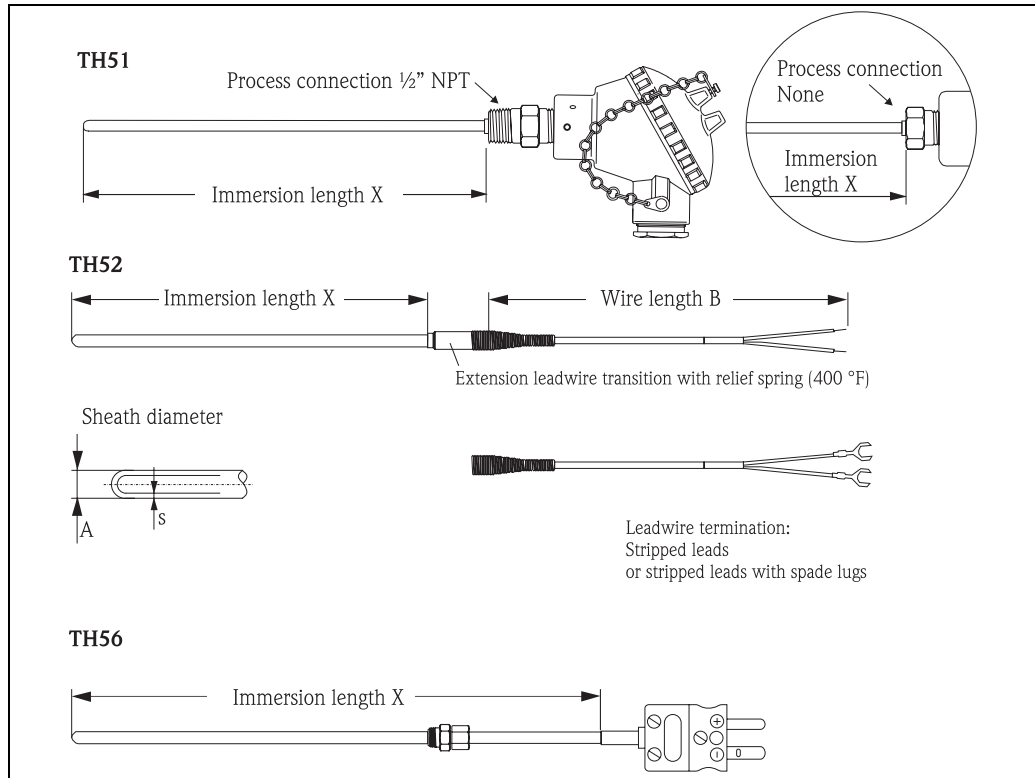

For values related to this graphic please refer to the table below.



Note!
Duplex version (2 elements) of TH56 is not available.

Dimensions in inches:

Immersion length X			Wire length B	Sheath diameter A	Wall thickness S
TH51	TH52	TH56			
4", 6", 9", 12"	6", 12", 18", 24"	12", 18", 24", 48", 72", 96"	48", 72", 120" specified length 12" to 3600" in 12" increments	Ø 1/16"	0.007"
				Ø 1/8"	0.014"
				Ø 3/16"	0.022"
				Ø 1/4"	0.029"
specified length 2" to 96" in 1/2" increments				Ø 3/8"	0.045"

Hot or measuring junction

Grounded junction



Grounded junction

The thermocouple junction is welded securely into the closure end of the sheath, becoming an integral part of the weld. This is a good general purpose, low cost junction providing faster response times than an ungrounded junction of similar sheath diameter. Grounded junctions should not be used with Type T thermocouples, due to the copper wire. For a reliable temperature reading of grounded thermocouples Transmitters with galvanic isolation are strongly recommended. iTEMP transmitters have galvanic isolation of min. 2kV (from the sensor input to the output and the housing).

Ungrounded junction



Ungrounded junction

The welded thermocouple junction is fully isolated from the welded closed end sheath. This junction provides electrical isolation to reduce problems associated with electrical interference. Ungrounded junctions are also recommended for use in extreme positive or negative temperatures, rapid thermal cycling and for ultimate corrosion resistance of the sheath alloy. iTEMP transmitters have an excellent noise immunity (EMC) meeting all requirements listed under IEC61326 for use in noisy environments.



Note!

Dual ungrounded elements supplied with individually isolated junctions, except Ø 1/16" which are supplied with common junctions.

Weight

From 1 to 5.5 lbs

Material

Sheath materials		
Material	Max. temp. rating	Application notice
316 SS ¹	1700 °F (927 °C)	Superior corrosion resistance
Inconel 600 ²	2100 °F (1149 °C)	Excellent oxidation and corrosion resistance at high temperature. Not to be used in sulphur atmosphere ³ .

- 1) Duplex Version of Type N General purpose MgO insulated thermocouples are not available with 316 SS sheaths.
- 2) Type T & J General purpose MgO insulated thermocouples are not available with Inconel 600 sheaths.
- 3) Inconel 600 maximum working temperature is 2100 °F (1149 °C) under oxidizing conditions: Reducing conditions reduce maximum temperature to 1900 °F (1038 °C). Must not be placed in sulfurous atmospheres over 1000 °F (538 °C).

System components

Housing

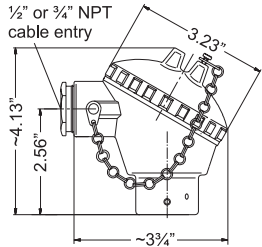
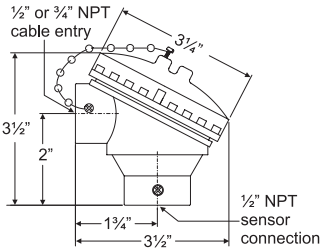
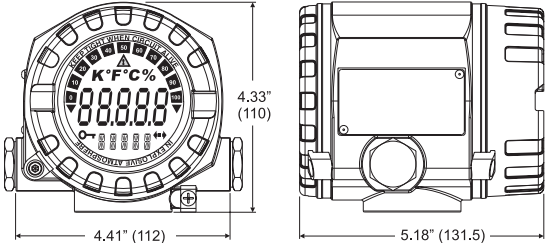
Type of housing (dimensions in inches [mm])	Specification
<p>Connection head Aluminium</p>  <p style="text-align: right; font-size: small;">T09-TH11xxxx-06-xx-xx-ae-001</p>	<ul style="list-style-type: none"> ■ Material: Die-cast Aluminum head ■ Sensor connection: 1/2" NPT Female ■ Cable entry: 1/2" NPT or 3/4" NPT Female. 1/2" NPT has got Al reducer bushing ■ Body paint: Spray SPU, RAL5012 Cover paint: Spray SPU, RAL7035 ■ Coating thread (body-cover), lubricant acc. E+H standard, MgO coating; benefits include ease of opening/closing cover and improved thread engagement. Improves life time of the connection head. ■ Degree of protection NEMA 4x (IP 66/68)
<p>Connection head plastic</p>  <p style="text-align: right; font-size: small;">T09-TH11xxxx-06-xx-xx-ae-000</p>	<ul style="list-style-type: none"> ■ Polypropylene, FDA compliant ■ Sensor connection: 1/2" NPT Female ■ Cable entry: 1/2" NPT or 3/4" NPT Female. 1/2" NPT with nylon reducer bushing (FDA compliant) ■ Degree of protection NEMA 4x
<p>SMART Temperature field transmitter iTEMP® HART® TMT 162</p>  <p style="text-align: right; font-size: small;">T09-TMT16ZZZ-06-00-xx-ae-002</p>	<ul style="list-style-type: none"> ■ Material: Die-cast aluminium housing AlSi10Mg with powder coating on polyester base or stainless steel AISI 316L SS ■ Separate electronics compartment and connection compartment ■ Display rotatable in 90° increments ■ Cable entry: 2 x 1/2" NPT or others ■ Degree of protection NEMA 4x (IP 67) ■ Brilliant blue backlit display with ease of visibility in bright sunshine or pitch darkness ■ Gold plated terminals to avoid corrosion and additional measurement errors <p>Details see Technical information (see 'Documentation')</p>

Head transmitter

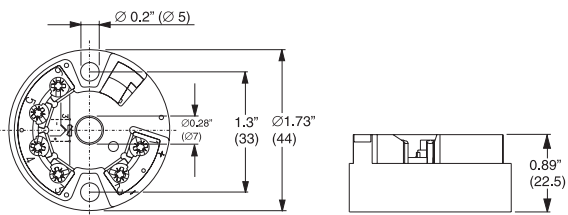
Type of transmitter (dimensions in inches [mm])	Specification
<p>iTEMP® TMT 181 and 182</p>  <p style="text-align: right; font-size: small;">R09-TMT18ZZZ-06-00-xx-ae-002</p>	<ul style="list-style-type: none"> ■ Material Housing: PC Potting: PUR ■ Terminals: Cable up to max. 16 AWG (secure screws) ■ Degree of protection NEMA 4 (see type of connection head) <p>Details see Technical Information (see 'Documentation')</p>

Compression fitting

All dimensions in inches

Type of fitting	Sheath Ø (T)	Process connection (PT)	Over all length (L)	Nut Hex (NH)	Body Hex (BH)
<p style="text-align: center; font-size: small;">T09-TH1112xx-03-xx-xx-ae-000</p>	1/16"	1/8"-27 NPT	1.03	5/16"	7/16"
	1/8"	1/8"-27 NPT	1.20	7/16"	7/16"
		1/4"-18 NPT	1.40	7/16"	9/16"
	3/16"	1/8"-27 NPT	1.23	1/2"	7/16"
		1/4"-18 NPT	1.43	1/2"	9/16"
	1/4"	1/8"-27 NPT	1.29	9/16"	1/2"
	1/4"	1/4"-18 NPT	1.49	9/16"	9/16"
	3/8"	1/4"-18 NPT	1.57	11/16"	5/8"

Material

- One time adjustable fitting
316 stainless steel coldfinished bar stock in accordance with ASTM A-479. Shaped bodies are machined from close-grained 316 stainless steel forgings in accordance with ASTM A-182.
- Re-adjustable fitting
316 stainless steel with TFE ferrule.

Certificates and approvals

CE Mark

The iTEMP® Series of temperature transmitters complies with the legal requirements laid out within the EU regulations.

Other standards and guidelines

- IEC 60529:
Degrees of protection by housing (IP-Code).
- IEC 61010:
Safety requirements for electrical measurement, control and laboratory instrumentation.
- IEC60584
Thermocouples - Reference tables
- ASTM E-230:
Standard Specification and Temperature-Electromotive Force (EMF) Tables for Standardized Thermocouples
- ASTM E839:
American society for testing and materials, Standard test methods for sheathed thermocouples and sheathed thermocouple material
- ASTM E-1129 / E 1129M - 98:
Standard Specification of Thermocouple connectors
- ASTM E-1684:
Standard Specification for Miniature Thermocouple Connectors
- NEMA - ANSI / NEMA 250
Standardization association for the electrical industry.

UL

Temperature transmitters are recognized components to UL 3111-1 (iTEMP® Series).

Ordering information

Product structure, Thermocouple assembly TH51

TH51-	Thermocouple Assembly, TH51 with connection head		
	Process connection:		
	A	None	
	B	1/2 NPT 316 SS	
	C	Comp.fitting 1/8 NPT 316 SS, one time	
	D	Comp.fitting 1/8 NPT 316 SS, readjustable	
	E	Comp.fitting 1/4 NPT 316 SS, one time	
	F	Comp.fitting 1/4 NPT 316 SS, readjustable	
	Y	Special	
	Immersion length X, 2 - 96 inch:		
	1	4 inch	
	2	6 inch	
	3	9 inch	
	4	12 inch	
	8 inch to spec.	
	9 inch special	
	Sheath diameter; Material:		
	B	1/8 inch; 316 SS	
	C	3/16 inch; 316 SS	
	E	1/4 inch; 316 SS	
	F	3/8 inch; 316 SS	
	J	1/8 inch; Inconel 600	
	K	3/16 inch; Inconel 600	
	L	1/4 inch; Inconel 600	
	M	3/8 inch; Inconel 600	
	Y	Special	
	Type Sensor; IEC Class:		
	A	1x J; 2	
	B	2x J; 2	
	C	1x J; 1	
	D	2x J; 1	
	E	1x K; 2	
	F	2x K; 2	
	G	1x K; 1	
	H	2x K; 1	
	J	1x E; 2	
	K	2x E; 2	
	L	1x E; 1	
	M	2x E; 1	
	N	1x N; 2	
	O	2x N; 2	
	P	1x N; 1	
	Q	2x N; 1	
	R	1x T; 2	
	S	2x T; 2	
	T	1x T; 1	
	U	2x T; 1	
	Y	Special	
	Junction style + purity:		
	1	grounded	
	2	ungrounded	
	9	special	
TH51-			← Order code (part 1)

**Product structure,
Thermocouple assembly
TH52**

TH52-	Thermocouple Assembly, TH52 with cable		
	Process connection:		
	A	None	
	C	Comp. fitting 1/8 NPT 316 SS, one time	
	D	Comp. fitting 1/8 NPT 316 SS, readjustable	
	E	Comp. fitting 1/4 NPT 316 SS, one time	
	F	Comp. fitting 1/4 NPT 316 SS, readjustable	
	Y	Special	
	Immersion length X, 2 - 96 inch:		
	1	6 inch	
	2	12 inch	
	3	18 inch	
	4	24 inch	
	8 inch to spec.	
	9 inch special	
	Sheath diameter; Material:		
	A	1/16 inch; 316 SS	
	B	1/8 inch; 316 SS	
	C	3/16 inch; 316 SS	
	E	1/4 inch; 316 SS	
	H	1/16 inch; Inconel 600	
	J	1/8 inch; Inconel 600	
	K	3/16 inch; Inconel 600	
	L	1/4 inch; Inconel 600	
	Y	Special	
	Type Sensor; IEC Class:		
	A	1x J; 2	
	B	2x J; 2	
	C	1x J; 1	
	D	2x J; 1	
	E	1x K; 2	
	F	2x K; 2	
	G	1x K; 1	
	H	2x K; 1	
	J	1x E; 2	
	K	2x E; 2	
	L	1x E; 1	
	M	2x E; 1	
	N	1x N; 2	
	O	2x N; 2	
	P	1x N; 1	
	Q	2x N; 1	
	R	1x T; 2	
	S	2x T; 2	
	T	1x T; 1	
	U	2x T; 1	
	Y	Special	
	Junction style + purity:		
	1	grounded	
	2	ungrounded	
	9	special	
	Wire length:		
	A	48 inch length	
	B	72 inch length	
	C	120 inch length	
	X	... inch wire length to spec.	
	Y	... inch special wire length	
TH52-			← Order code (part 1)

**Product structure,
Thermocouple assembly
TH56**

TH56-	Thermocouple Assembly, TH56 with plug		
	Process connection:		
	A	None	
	C	Comp. fitting 1/8 NPT 316 SS, one time	
	D	Comp. fitting 1/8 NPT 316 SS, readjustable	
	E	Comp. fitting 1/4 NPT 316 SS, one time	
	F	Comp. fitting 1/4 NPT 316 SS, readjustable	
	Y	Special	
	Immersion length X, 2 - 96 inch:		
	1	12 inch	
	2	18 inch	
	3	24 inch	
	4	48 inch	
	5	72 inch	
	6	96 inch	
	8 inch to spec.	
	9 inch special	
	Sheath diameter; Material:		
	A	1/16 inch; 316 SS	
	B	1/8 inch; 316 SS	
	C	3/16 inch; 316 SS	
	E	1/4 inch; 316 SS	
	H	1/16 inch; Inconel 600	
	J	1/8 inch; Inconel 600	
	K	3/16 inch; Inconel 600	
	L	1/4 inch; Inconel 600	
	Y	Special	
	Type Sensor; Class:		
	A	1x J; 2	
	C	1x J; 1	
	E	1x K; 2	
	G	1x K; 1	
	J	1x E; 2	
	L	1x E; 1	
	N	1x N; 2	
	P	1x N; 1	
	R	1x T; 2	
	T	1x T; 1	
	Y	Special	
	Junction style + purity:		
	1	grounded	
	2	ungrounded	
	9	special	
	Connector style:		
	A	Standard	
	B	Standard + female	
	C	Mini	
	D	Mini + female	
	E	Standard, high temp.	
	G	Standard + female, high temp.	
	Y	Special	
TH56-			← Order code (part 1)

Documentation

- Compact instructions TH51 Thermocouple assembly with connection head (KA 184r/24/ae)
- Compact instructions TH52 Thermocouple assembly with cable (KA 185r/24/ae)
- Compact instructions TH56 Thermocouple assembly with plug (KA 186r/24/ae)
- Technical information SMART Temperature field transmitter iTEMP® HART® TMT162 (TI 086r/24/ae)
- Technical information Temperature head transmitter iTEMP® PCP TMT 181 (TI 070r/24/ae)
- Technical information Temperature head transmitter iTEMP® HART® TMT 182 (TI 078r/24/ae)

Application example:

- Technical information Temperature transmitter iTEMP® PCP DIN rail TMT 121 (TI 087r/24/ae)
- Technical information Temperature transmitter iTEMP® HART® DIN rail TMT 122 (TI 090r/24/ae)
- Technical information Process display RIA 261 (TI 083r/24/ae)
- Technical information Power supply RNS 221 (TI 081r/24/ae)
- Technical information Color hybrid recorder alpha-log, RSA10 (TI 051r/09/en)

United States

Endress+Hauser, Inc.
2350 Endress Place
Greenwood, IN 46143
Tel: 317-535-7138
Sales: 888-ENDRESS
Service: 800-642-8737
FAX: 317-535-8498
inquiry@us.endress.com
www.us.endress.com

Canada

Endress+Hauser Canada
1075 Sutton Drive
Burlington, ON L7L 5Z8
Tel: 905-681-9292
800-668-3199
FAX: 905-681-9444
www.ca.endress.com

Mexico

Endress+Hauser
Paseo del Pedregal No. 610
Col, Jardines del Pedregal
01900, Mexico D. F.
Mexico
Tel: 525-568-2405
FAX: 525-568-7459

Endress + Hauser 

People for Process Automation