

Type 8081

Flowmeter for continuous measurement of water

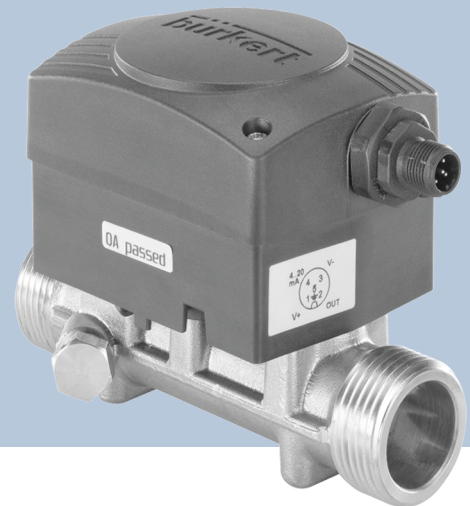

Operating Instructions

We reserve the right to make technical changes without notice.

© Bürkert Werke GmbH & Co. KG 2008-2026

Technical documentation 2602/05_GBen_00560456_1282192907_1282395147 / Original EN

Inhaltsverzeichnis

1	About this document	4
1.1	Symbols	4
1.2	Terms and abbreviations	5
1.3	Manufacturer	5
2	Safety	6
2.1	Intended Use	6
2.2	Basic safety information	6
3	Description	8
3.1	Area of application	8
3.2	General description	8
3.2.1	Design	8
3.2.2	Measuring item and principle	8
3.3	Description of the type label	9
4	Technical Data	10
4.1	Standards and directives	10
4.2	Conditions of use	10
4.3	Conformity to the pressure equipment directive	10
4.4	Mechanical data	11
4.5	Dimensions	11
4.6	Fluid data	11
4.7	Electrical data	13
4.8	Electrical connections	13
5	Installation and Wiring	14
5.1	Safety instructions	14
5.2	Installation onto the pipe	14
5.3	Electrical wiring	16
5.3.1	Assembly of the female cable plug (article number 438680)	17
5.3.2	Wiring of the 5-pin M12 fixed connector	17
5.3.3	Connecting the pulse output	18
5.3.4	Only connecting the current output	18
5.3.5	Connecting both the current and pulse outputs	19
6	Commissioning	20
6.1	Safety instructions	20
7	Adjustment and Functions	21
7.1	Safety instructions	21
7.2	Adjustment of the 8081	21
8	Maintenance	22
8.1	Safety instructions	22
8.2	Cleaning	22
9	Logistics	23
9.1	Transport and storage	23
9.2	Return	23
9.3	Disposal	23

1 About this document

The document is an important part of the product and guides the user to safe installation and operation. The information and instructions in this document are binding for the use of the product.

- ▶ Before using the product for the first time, read and observe the whole safety chapter.
- ▶ Before starting any work on the product, read and observe the respective sections of the document.
- ▶ Keep the document available for reference and give it to the next user.
- ▶ Contact the Bürkert sales office for any questions.



Further information concerning the product at [Products](#).

- ▶ Enter the article number from the type label in the search bar.

The illustrations in these instructions may vary depending on the product variant.

1.1 Symbols



DANGER!

Warns of a danger that leads to death or serious injuries.



WARNING!

Warns of a danger that can lead to death or serious injuries.



CAUTION!

Warns of a danger that can lead to minor injuries.

NOTICE!

Warns of property damage on the product or the installation.



Indicates important additional information, tips and recommendations.



Refers to information in this document or in other documents.

- ▶ Indicates a step to be carried out.

✓ Indicates a result.

Menu Indicates a software user-interface text.

1.2 Terms and abbreviations

The terms and abbreviations are used in this document to refer to following definitions.

Product	Water flow rate transmitter Type 8081
---------	---------------------------------------

1.3 Manufacturer

Bürkert Fluid Control Systems

Christian-Bürkert-Str. 13-17

74653 Ingelfingen

GERMANY

The contact addresses are available at [Contact](#).



Need more information or additional products?

- ▶ Explore the full range of products on our [eShop](#).

2 Safety

2.1 Intended Use

Use of the ultrasonic flow rate transmitter that does not comply with the instructions could present risks to people, nearby installations and the environment.

- ▶ The 8081 transmitter is intended solely for the measurement of the flow rate in water or neutral liquids.
- ▶ If possible, avoid placing this device near sources of electromagnetic interference.
- ▶ This device must be protected against ultraviolet rays and, when installed outdoors, the effects of the climatic conditions.
- ▶ This device must be used in compliance with the characteristics and commissioning and use conditions specified in the contractual documents and in the user manual.
- ▶ The device can only be used together with devices and components recommended and/or approved by Bürkert.
- ▶ Requirements for safe and proper operation are proper transport, storage and installation as well as careful operation and maintenance.
- ▶ Only use the device as intended.

2.2 Basic safety information

This safety information does not take into account:

- ▶ any contingencies or occurrences that may arise during assembly, use and maintenance of the devices.
- ▶ the local safety regulations that the operator must ensure the staff in charge of assembly observe.

Danger due to high pressure

Danger due to high temperatures of the fluid

Danger due to electrical voltage

Various dangerous situations

To avoid injury take care:

- ▶ to prevent any power supply switch on.
- ▶ to carry out the installation and maintenance work by qualified and skilled staff with the appropriate tools.
- ▶ to guarantee a set or controlled restarting of the process, after a power supply interruption.
- ▶ to use the device only if in perfect working order and in compliance with the instructions provided in the user manual
- ▶ to observe the general technical rules during the planning and use of the device.
- ▶ not to use the type 8081 ultrasound flow rate transmitter in a potentially explosive atmosphere.
- ▶ not to use fluid that is incompatible with the materials of which the transmitter is made.

- ▶ not to subject the device to mechanical loads (e.g. by placing objects on top of it or by using it as a step).
- ▶ not to make any external modifications to the device. Do not paint or varnish any part of the device.

Elements / Components sensitive to electrostatic discharges

This device contains electronic components sensitive to electrostatic discharges. They can get damaged if they are touched by an electrostatically charged person or object. In the worst case scenario, these components are instantly destroyed or go out of order as soon as they are activated.

- ▶ To minimise or even avoid all damage due to an electrostatic discharge, take all the precautions described in the EN 61340- 5-1 norm.
- ▶ Also ensure that you do not touch any of the live electrical components.

3 Description

3.1 Area of application

The ultrasonic flow rate transmitter type 8081 is intended for the measurement of water flow rates which may be slightly charged with contaminants.

3.2 General description

3.2.1 Design

The 8081 ultrasonic flow rate transmitter consists of an electronic module and a brass fitting with a built-in measuring tube. When combined with a controller and a control loop, it enables a control loop to be established.

The electrical connection is made via a 5-pin M12 fixed connector.

The transmitter features, depending on the version:

- a pulse output or
- a pulse output and a 4...20 mA current output;

Each version is available for 5 different flow rate ranges:

- model QN 0.6 DN15: 0.06 to 20 l/min (nominal flow rate 0.6 m³/h namely 10 l/min)
- model QN 1.5 DN15: 0.1 to 50 l/min (nominal flow rate 1.5 m³/h namely 25 l/min)
- model QN 2.5 DN20: 0.16 to 82 l/min (nominal flow rate 2.5 m³/h namely 41 l/min)
- model QN 3.5 DN25: 0.6 to 116 l/min (nominal flow rate 3.5 m³/h namely 58 l/min)
- model QN 6 DN25: 1 to 200 l/min (nominal flow rate 6 m³/h namely 100 l/min)

3.2.2 Measuring item and principle

The 8081 flow meter is based on the transit time method. This consists in measuring the transit times of the sound from emitter 1 to receiver 2 and from emitter 2 to receiver 1 and subsequently comparing both values. The calculated transit time difference is directly proportional to the flow speed of the fluid.

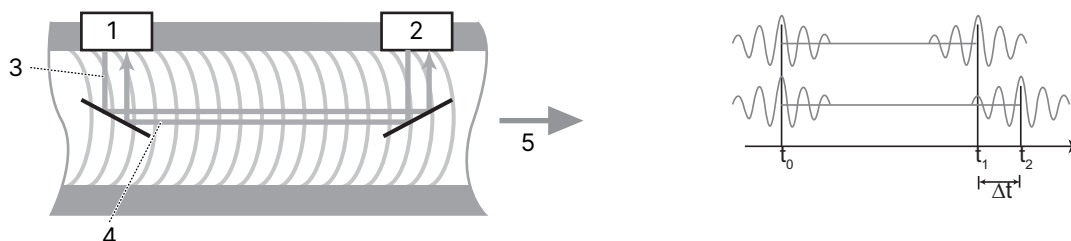

1 Emitter-receiver 1

2 Emitter-receiver 2

3 Ultrasonic wave 1

4 Ultrasonic wave 2

5 Direction of flow of the fluid

Type 8081

Description

The electronic module then delivers a pulse signal proportional to the volume or an industry-standard 4...20 mA signal, proportional to the flow rate or to the temperature.

3.3 Description of the type label

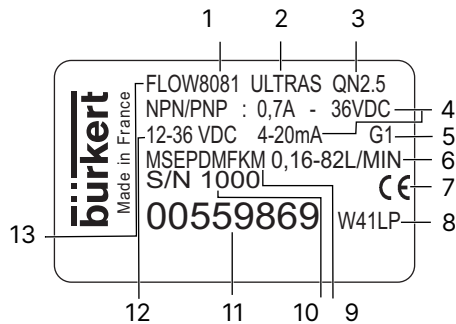

1 Type	2 Measuring principle
3 Nominal flow rate	4 Output data
5 Process connection	6 Flow rate range
7 CE marking	8 Manufacture code
9 Materials: housing, seal	10 Serial number
11 Article number	12 Operating voltage
13 Measured quantity	

4 Technical Data

4.1 Standards and directives

This product complies with the legal requirements applicable at the time of placing on the market and has been developed and tested in accordance with the relevant European directives/regulations and harmonized standards. The conformity is documented and, if necessary, supported by evidence. The EU Declaration of Conformity can be found behind the respective type on the home page country.burkert.com

4.2 Conditions of use

Conditions of use	+5...+55 °C
Storage temperature	+5...+55 °C
Air humidity	< 80 %, not condensated
Protection rating	IP65 with cable plug plugged-in and tightened

4.3 Conformity to the pressure equipment directive

- ▶ Make sure that the device materials are compatible with the fluid.
- ▶ Make sure that the pipe DN is adapted for the device.
- ▶ Observe the fluid nominal pressure (PN) for the device. The nominal pressure (PN) is given by the device manufacturer.

The device conforms to Article 4, Paragraph 1 of the Pressure Equipment Directive 2014/68/EU under the following conditions:

- Device used on a piping (PS = maximum admissible pressure; DN = nominal diameter of the pipe)

Type of fluid	Conditions
Fluid group 1, Article 4, Paragraph 1.c.i	Forbidden
Fluid group 2, Article 4, Paragraph 1.c.i	DN ≤ 32 or PSxDN ≤ 1000 bar
Fluid group 1, Article 4, Paragraph 1.c.ii	Forbidden
Fluid group 2, Article 4, Paragraph 1.c.ii	DN ≤ 200 or PS ≤ 10 bar or PSxDN ≤ 5000 bar

4.4 Mechanical data

Item	Material
Housing, cover	PPS
Seal in contact with the environment	Silicone
M12 connector	PA
Fitting	Brass
Measuring tube	PES
Seal in contact with the fluid	EPDM, FKM

4.5 Dimensions

Refer to the related datasheet at [Type 8081](#)

4.6 Fluid data

Pipe diameter	DN15 to DN25
Type of fluid	water (or neutral liquids on request)
Fluid temperature	+5...+90 °C
Fluid pressure	PN 16
Measuring range	0.06...200 l/min
Accuracy (see curves on next page)	± (0.01 % of Full Scale ¹⁾ +2 % of measured value ²⁾
Repeatability	1 % of measured value
Measuring element	2 ultrasound emitter-receiver cells

1) Full Scale, see measuring range on the diagram of measurement accuracy

2) Reference conditions: fluid = water, water and ambient temperatures = 20 °C

Measurement accuracy

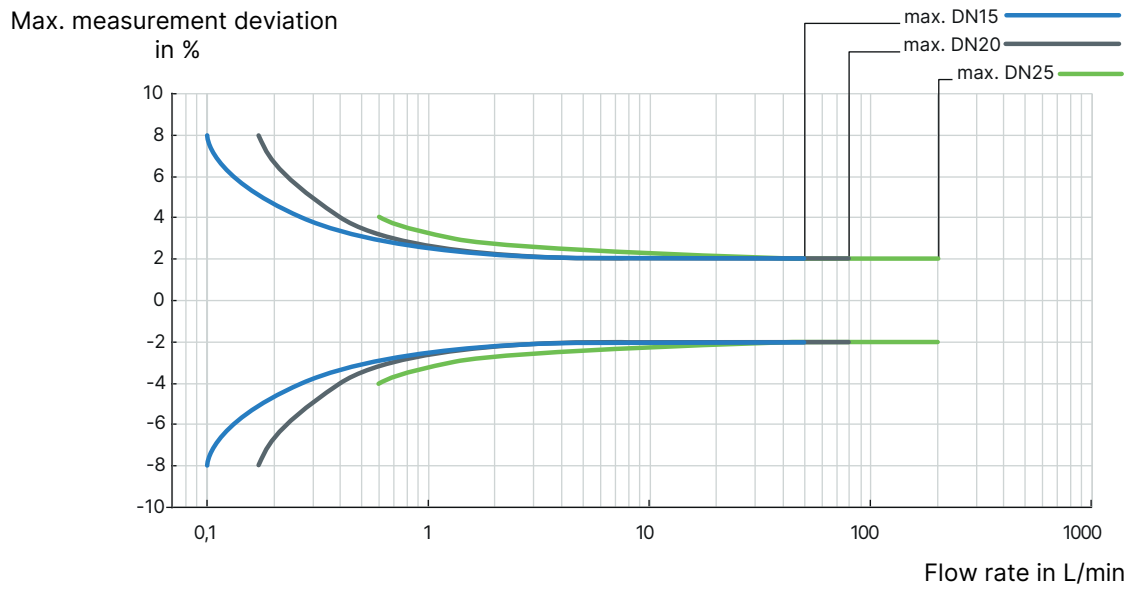

4.7 Electrical data

Supply voltage (V+)	12...36 V DC
Current consumption	<ul style="list-style-type: none"> • Own consumption: < 4 mA • Consumption with load: < 1 A
Pulse output (transistor)	
<ul style="list-style-type: none"> • version without current output • version with current output 	<ul style="list-style-type: none"> • NPN as default setting; (PNP on request), open collector, 5 mA min., 700 mA max., NPN output: 0,2...36 V DC • PNP as default setting; (on request: NPN for the pulse output and sinking mode for the current output), open collector, 5 mA min., 700 mA max., PNP output: supply voltage (V+) <p>If QN=0.6 or 1.5: 1 pulse corresponds to a volume V = 0.002 l (K factor = 500 pulse/litre)</p> <p>If QN=2.5 or 3.5: 1 pulse corresponds to a volume V = 0.005 l (K factor = 200 pulse/litre)</p> <p>If QN=6: 1 pulse corresponds to a volume V = 0.01 l (K factor = 100 pulse/litre)</p>
Current output	<p>4...20 mA (sourcing mode as default setting; on request: sinking mode for the current output and NPN for the pulse output) corresponding to the flow rate range of the selected model max. loop resistance:</p> <p>1100 W at 36 V DC 610 W at 24 V DC 100 W at 12 V DC</p> <p>Accuracy: ±0.4 % of Full Scale (16 mA)</p>
Protection against: reversed polarity	yes
reversed polarity	yes
voltage peaks	yes, for the pulse output
short-circuits	
Recommended cable type	max. cross section of 1.5 mm ²

4.8 Electrical connections

Flow rate meter version	Type of cable plug
Any version	female 5-pin M12 cable plug (available as an accessory; Article number 438680)

5 Installation and Wiring

5.1 Safety instructions



DANGER!

Risk of injury due to high pressure

- ▶ Cut off the pressure and depressurize the pipes before loosening the pipes and connections.



DANGER!

Risk of injury due electrical discharge

- ▶ If the device is installed either in a wet environment or outdoors, all the electrical voltages must be of max. 35 V DC.
- ▶ Before starting work, make sure that you switch off the supply voltage and secure it to prevent restarting.
- ▶ Observe all applicable accident protection and safety guidelines for electrical equipment.



WARNING!

Risk of injury due to non-conforming installation

- ▶ The electrical and fluid installation can only be carried out by qualified and skilled staff with the appropriate tools.
- ▶ Install appropriate safety devices (correctly rated fuse and/or circuit-breaker).
- ▶ Use cables with an operating temperature limit which is suitable for your application.
- ▶ Under normal conditions of use, cables with a 0.75 mm² cross section should be enough to transmit the signal.



WARNING!

Risk of injury due to unintentional switch on of power supply or uncontrolled restarting of the installation

- ▶ Take appropriate measures to avoid any involuntary activation of the installation.
- ▶ Guarantee a set or controlled restarting of the process subsequent to the assembly of the device.

NOTICE!

When the cover is removed, the transmitter may be damaged through any element touching the electronics, and the tightness of the transmitter is no longer ensured

- ▶ Do not dismantle the device

5.2 Installation onto the pipe



DANGER!

Risk of injury due to high pressure in the installation

- ▶ Cut off the pressure and depressurize the pipes before loosening the pipes and connections.

The 8081 ultrasonic flow rate transmitter can be fitted onto a horizontal or vertical pipe.

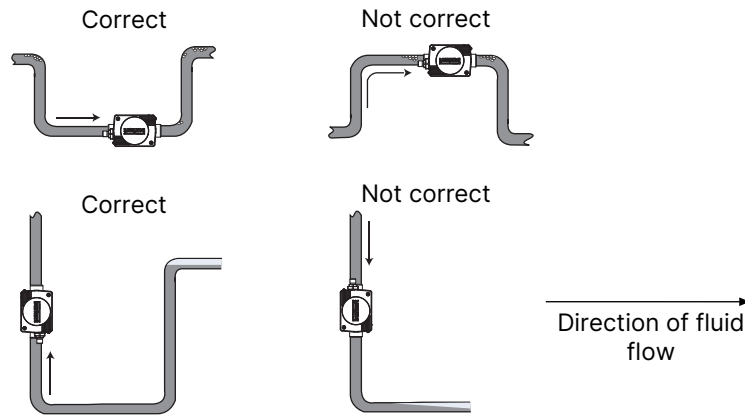

When horizontally mounted, the max. fluid temperature is 90 °C. But the max. fluid temperature must be reduced to 80 °C when the electronics (black enclosure) is turned upwards.

When vertically mounted the max. fluid temperature is also 80 °C.

- ▶ **CAUTION! Please be careful to respect the correct direction of fluid flow in the pipe.** It is indicated with an arrow, marked on the underside of the fitting.

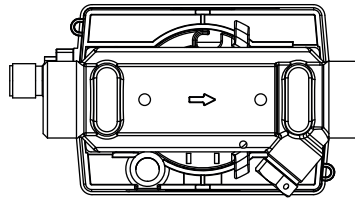

It is advisable to avoid placing the 8081 transmitter near any source of electromagnetic interference (switch, electric motor, fluorescent lamp, ...).

Minimum upstream and downstream distances are not necessary. The 8081 works correctly when the pipe is full and free of any air bubbles near the transmitter. In presence of bubbles in the pipe, the left installation no.1 should be avoided.

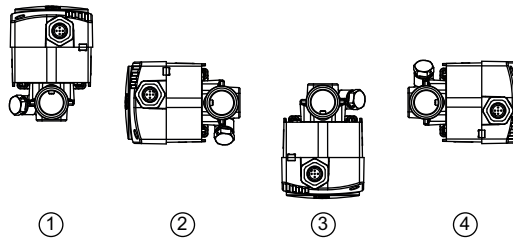

If the absence of any air bubbles cannot be guaranteed, the device should then be fitted on an horizontal pipe, with the electronic enclosure facing down. Thus the bubbles will not interfere with the circulation of ultrasonic waves.

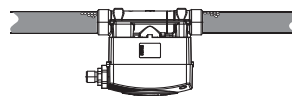

NOTICE!

When mounting the device on the pipe, the M 12 fixed connector may be damaged
If the M12 fixed connector is damaged the device cannot be used anymore.

- ▶ Please be careful not to damage the M12 fixed connector when mounting the device on the pipe.

5.3 Electrical wiring

DANGER!

Risk of injury due to electrical discharge

- ▶ If the device is installed either in a wet environment or outdoors, all the electrical voltages must be of max. 35 V DC.
- ▶ Before starting work, make sure that you switch off the supply voltage and secure it to prevent restarting.
- ▶ Do not install the cable near high voltage or high frequency cables.
- ▶ If this is unavoidable, keep to a minimum clearance of 30 cm.
- ▶ Observe all applicable accident protection and safety guidelines for electrical equipment



The power supply must be filtered and regulated.

- ▶ Make sure the installation is earthed equipotentially (power supply - 8081).
- ▶ Connect the different earth connections of the installation to one another in order to remove any differences in potential which may arise between the two earth connections.
- ▶ Connect the cable shielding to the earth. Connect the negative terminal of the power supply to the earth to remove the effects of the common mode currents. If this connection cannot be made directly, a 100 nF / 50 V capacitor can be fitted between the negative terminal of the power supply and the earth.

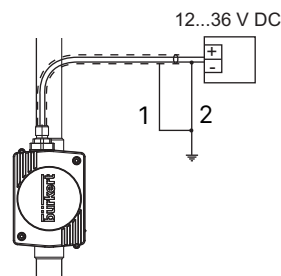

1 If a direct earthing connection is not possible, fit a 100 nF / 50 V capacitor between the negative terminal of the power supply and the earth

2 If your cable is shielded

5.3.1 Assembly of the female cable plug (article number 438680)

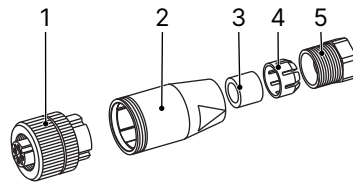

1 Terminal block	2 Body
3 Gasket	4 Clamp ring
5 Clamping nut	

- ▶ Fully unscrew terminal block
- ▶ Remove body.
- ▶ Unscrew clamping nut.
- ▶ Pass cables through clamping nut, then through clamp ring and gasket , and finally through body.
- ▶ Wire terminal block (acc. to [Wiring of the 5-pin M12 fixed connector \[▶ 17\]](#), [Connecting the pulse output \[▶ 18\]](#), [Only connecting the current output \[▶ 18\]](#) or [Connecting both the current and pulse outputs \[▶ 19\]](#)).
- ▶ Screw terminal block onto body.
- ▶ Insert gasket and clamp ring into body.
- ▶ Screw clamping nut.

5.3.2 Wiring of the 5-pin M12 fixed connector

Wiring a version with pulse output

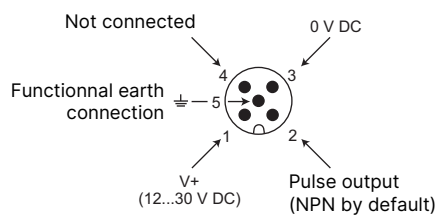

Wiring a version with pulse and current outputs

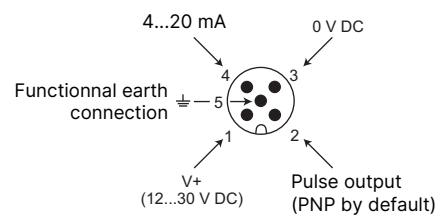

Pin of M12 cable plug with a 2 m cable available as accessory (article number 438680)	Colour of wire
1	brown
2	white
3	blue
4	black
5	grey

5.3.3 Connecting the pulse output

The pulse output is connected in NPN mode (default setting on a version without current output) or in PNP mode (default setting on a version with current output).

NPN connection

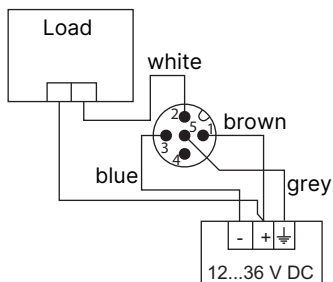

PNP connection

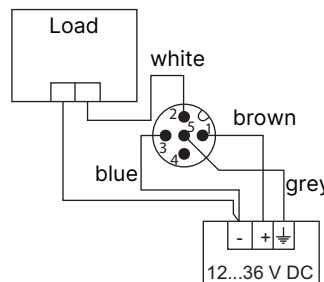

5.3.4 Only connecting the current output

The current output, where present, is connected in source mode (default setting) or in sink mode (on request).

Source mode connection (default setting)

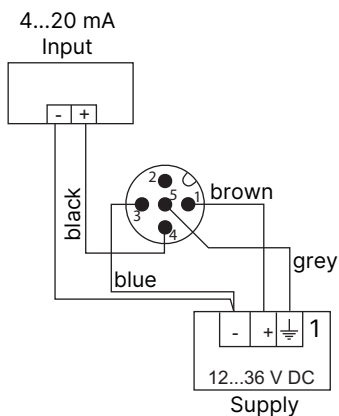

Sink mode connection (on request)

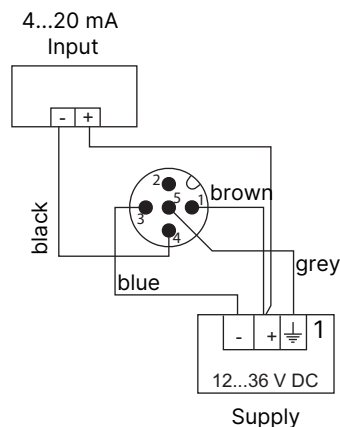

1: If a direct earthing connection is not possible, fit a 100 nF / 50 V capacitor between the negative terminal of the power supply and the earth.

5.3.5 Connecting both the current and pulse outputs

PNP/sourcing mode connection (default setting) NPN/sinking mode connection (on request)

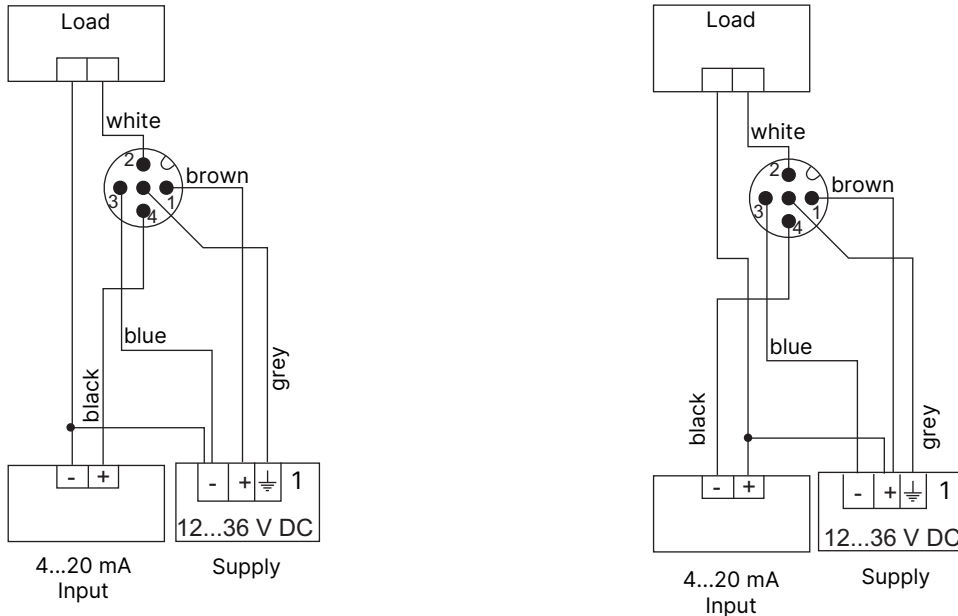

1: If a direct earthing connection is not possible, fit a 100 nF / 50 V capacitor between the negative terminal of the power supply and the earth.

6 Commissioning

6.1 Safety instructions



WARNING!

Danger due to non-conforming commissioning

Non-conforming commissioning could lead to injuries and damage the device and its surroundings.

- ▶ Before commissioning, make sure that the staff in charge have read and fully understood the contents of the manual.
- ▶ In particular, observe the safety recommendations and standard operating practices.
- ▶ The device/installation must only be commissioned by suitably trained staff.
- ▶ Protect the device against electromagnetic interference, ultraviolet rays and, when installed outdoors, the effects of the climatic conditions.

7 Adjustment and Functions

7.1 Safety instructions



WARNING!

Risk of injury due to non-conforming adjustment

- ▶ The operators in charge of adjustment must have read and understood the contents of this manual.
- ▶ In particular, observe the safety recommendations and standard operating practices.
- ▶ The device/installation must only be adjusted by suitably trained staff.

7.2 Adjustment of the 8081

- Pulse output:

The pulse output delivers a frequency in proportion to a volume

A pulse is generated each time a set volume passes, i.e. either

V = 0.002 litre (for a model with QN = 0.6 or 1.5)

or V = 0.005 litre (for a model with QN = 2.5 or 3.5)

or V = 0.01 litre (for a model with QN = 6).

- Current output:

The current output, where present, is pre-programmed on the current range corresponding to the flow rate range (QN0.6, QN1.5, QN2.5, QN 3.5 or QN6) of the selected 8081 model.

8 Maintenance

8.1 Safety instructions



DANGER!

Risk of injury due to high pressure in the installation

- ▶ Cut off the pressure and depressurize the pipes before loosening the pipes and connections.



DANGER!

Risk of injury due to electrical discharge

- ▶ If the device is installed either in a wet environment or outdoors, all the electrical voltages must be of max. 35 V DC.
- ▶ Before starting work, be sure to switch off the supply voltage and secure it to prevent restarting.
- ▶ Observe the applicable accident prevention and safety regulations for electrical equipment.



WARNING!

Danger due to non-conforming maintenance

- ▶ Maintenance must only be carried out by qualified and skilled staff with the appropriate tools.
- ▶ Following maintenance, ensure a controlled restart.

8.2 Cleaning

The 8081 flow meter can be cleaned with water or using a detergent compatible with the materials it is made of.

Please feel free to contact your Bürkert supplier for any additional information.

9 Logistics

9.1 Transport and storage

- ▶ Protect the device against moisture and dirt in the original packaging during transportation and storage.
- ▶ Avoid UV radiation and direct sunlight.
- ▶ Protect connections, if present, from damage with protective caps.
- ▶ Observe the permitted storage temperature.

9.2 Return



No work or tests will be carried out on the device until a valid Contamination Declaration has been received.

- ▶ To return a used device to Bürkert, contact the Bürkert sales office. A return number is required.

9.3 Disposal

Environmentally friendly disposal



- ▶ Follow national regulations regarding disposal and the environment.
- ▶ Collect electrical and electronic devices separately and dispose of them as special waste.

Further information at country.burkert.com