

Screw-in thermowell (fabricated) Version per DIN 43772 form 5, 8 Models TW45-F, TW45-G

WIKA data sheet TW 95.45

Applications

- Chemical industry, process technology, apparatus construction
- For low and medium process loads

Special features

- Version per DIN 43772
- Model TW45-F: Form 5
Model TW45-G: Form 8

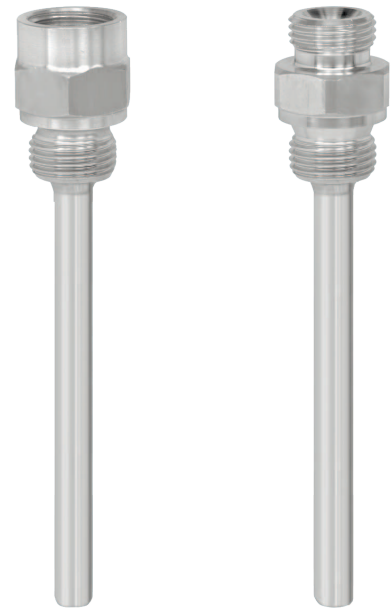

Screw-in thermowell

Fig. left: Model TW45-F

Fig. right: Model TW45-G

Description

Each thermowell is an important component of any temperature measurement point. It is used to separate the process from the surrounding area, thus protecting the environment and operating personnel and keeps aggressive media, high pressures and flow rates from the temperature sensor itself and thereby enables the thermometer to be exchanged during operation.

Based on the almost limitless application possibilities, there are a large number of variants, such as thermowell designs or materials. The type of process connection and the basic method of manufacture are important design differentiation criteria. A basic differentiation can be made between threaded and weld-in thermowells, and those with flange connections.

Furthermore, one can differentiate between fabricated and solid-machined thermowells. Fabricated thermowells are constructed from a tube, that is closed at the tip by a welded solid tip. Solid-machined thermowells are manufactured from barstock.

The TW45 series of fabricated ¹⁾ screw-in thermowells are suitable for use with numerous electrical and mechanical thermometers from WIKA.

Due to their design to DIN 43772, these thermowells for low and medium process loads are suitable for use in the chemical industry, process technology and equipment manufacture.

1) For short insertion lengths (copper alloy) solid-machined version optionally

Standard version

Thermowell material

Stainless steel 1.4571 or copper alloy

Process connection

G ½ B, G ¾ B male

Connection to thermometer

Model TW45-F: G ½, G ¾ female

Model TW45-G: G ½ B, G ¾ B male

Bore size

Versions per DIN 43772:

Ø 7 mm, Ø 9 mm, Ø 11 mm

Designs similar to DIN 43772, but with fast response:

Ø 6.2 mm, Ø 8.2 mm, Ø 8.5 mm, Ø 10.2 mm

Insertion length U₁

Model TW45-F: 82, 142, 182, 232, 382 mm

Model TW45-G: 73, 110, 170, 260, 410 mm

Overall length L

Installation length U₁ + 28 mm

Max. process temperature, process pressure

160 °C with copper alloy as thermowell material (6 bar stat.)

Depending on

- Load diagram DIN 43772

- Thermowell design

 - Dimensions

 - Material

- Process conditions

 - Flow rate

 - Density of medium

Options

- Other dimensions and materials

- Quality certificates

- Thermowell calculation to Dittrich/Klotter is recommended in critical applications as a WIKA engineering service.

For further informations, see Technical information IN 00.15

"Strength calculation for thermowells".

Dimensions in mm

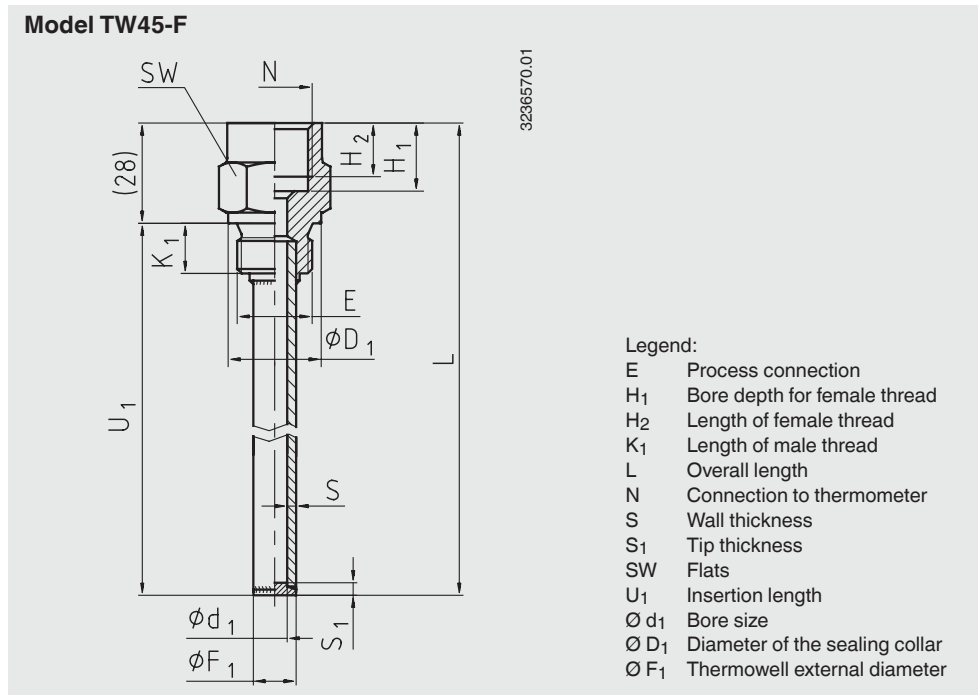

Material	Dimensions in mm											Weight in kg	
	E	N	Ø d ₁	Ø D ₁	Ø F ₁	H ₁	H ₂	K ₁	S	S ₁	SW	U ₁ = 82 mm	U ₁ = 382 mm
Stainless steel 1.4571	G ½ B	G ½	7	26	12	19	15	14	2.5	3.5	27	0.15	0.33
	G ½ B	G ½	9	26	14	19	15	14	2.5	3.5	27	0.15	0.36
	G ½ B	G ½	11	26	14	19	15	14	1.5	2.5	27	0.12	0.28
	G ½ B	G ½	6.2	26	8	19	15	14	0.9	1	27	0.12	0.18
	G ½ B	G ½	8.2	26	10	19	15	14	0.9	1	27	0.12	0.18
	G ½ B	G ½	10.2	26	12	19	15	14	0.9	1	27	0.12	0.19
	G ¾ B	G ½	7	32	12	19	15	16	2.5	3.5	32	0.24	0.42
	G ¾ B	G ½	9	32	14	19	15	16	2.5	3.5	32	0.24	0.45
	G ¾ B	G ½	11	32	14	19	15	16	1.5	2.5	32	0.22	0.37
	G ¾ B	G ½	6.2	32	8	19	15	16	0.9	1	32	0.21	0.27
	G ¾ B	G ½	8.2	32	10	19	15	16	0.9	1	32	0.21	0.27
	G ¾ B	G ½	10.2	32	12	19	15	16	0.9	1	32	0.21	0.28
	G ¾ B	G ¾	7	32	12	22	17	16	2.5	3.5	32	0.20	0.38
	G ¾ B	G ¾	9	32	14	22	17	16	2.5	3.5	32	0.20	0.41
	G ¾ B	G ¾	11	32	14	22	17	16	1.5	2.5	32	0.18	0.33
	G ¾ B	G ¾	6.2	32	8	22	17	16	0.9	1	32	0.17	0.23
G ¾ B	G ¾	8.2	32	10	22	17	16	0.9	1	32	0.17	0.23	
G ¾ B	G ¾	10.2	32	12	22	17	16	0.9	1	32	0.17	0.24	
Copper alloy	G ½ B	G ½	8.5	26	10	19	15	14	0.75	0.75	27	0.11	0.18
	G ¾ B	G ½	8.5	32	10	19	15	16	0.75	0.75	32	0.23	0.29

Suitable insertion lengths

■ Mechanical dial thermometers

Connection type	Insertion length l ₁
S ¹⁾ , 4, 5	l ₁ = L - 10 mm or l ₁ = U ₁ + 18 mm
2	l ₁ = L - 30 mm or l ₁ = U ₁ - 2 mm

1) Not suitable for use with an thermowell inner diameter of Ø 6.2 mm (pipe 8 x 0.9 mm), Ø 8.2 mm (pipe 10 x 0.9 mm) and 10.2 mm (pipe 12 x 0.9 mm).

■ Machine glass thermometers

Connection type	Insertion length l ₁
E	l ₁ = L - 10 mm or l ₁ = U ₁ + 18 mm

Model TW45-G

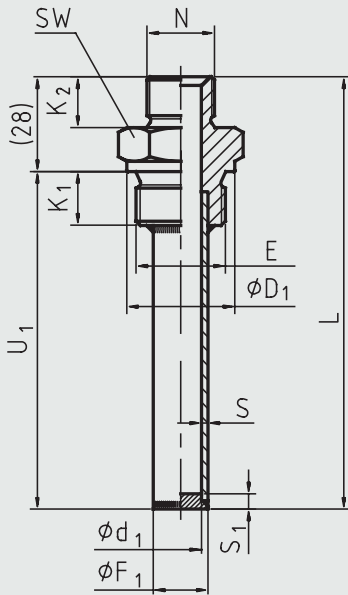

3236688.01

Legend:

E	Process connection
K ₁	Length of male thread
K ₂	Length of male thread for thermometer
L	Overall length
N	Connection to thermometer
S	Wall thickness
S ₁	Tip thickness
SW	Flats
U ₁	Insertion length
Ø d ₁	Bore size
Ø D ₁	Diameter of the sealing collar
Ø F ₁	Thermowell external diameter

Material	Dimensions in mm										Weight in kg	
	E	N	Ø d ₁	Ø D ₁	Ø F ₁	K ₁	K ₂	S	S ₁	SW	U ₁ = 73 mm	U ₁ = 410 mm
Stainless steel 1.4571	G ½ B	G ½ B	7	26	12	14	12	2.5	3.5	27	0.14	0.34
	G ½ B	G ½ B	9	26	14	14	12	2.5	3.5	27	0.14	0.37
	G ½ B	G ½ B	11	26	14	14	12	1.5	2.5	27	0.12	0.30
	G ½ B	G ½ B	6.2	26	8	14	12	0.9	1	27	0.13	0.20
	G ½ B	G ½ B	8.2	26	10	14	12	0.9	1	27	0.13	0.20
	G ½ B	G ½ B	10.2	26	12	14	12	0.9	1	27	0.11	0.18
	G ¾ B	G ¾ B	7	32	12	16	14	2.5	3.5	32	0.22	0.43
	G ¾ B	G ¾ B	9	32	14	16	14	2.5	3.5	32	0.22	0.46
	G ¾ B	G ¾ B	11	32	14	16	14	1.5	2.5	32	0.20	0.39
	G ¾ B	G ¾ B	6.2	32	8	16	14	0.9	1	32	0.21	0.28
	G ¾ B	G ¾ B	8.2	32	10	16	14	0.9	1	32	0.21	0.28
	G ¾ B	G ¾ B	10.2	32	12	16	14	0.9	1	32	0.20	0.27

Suitable insertion lengths

■ Mechanical dial thermometers

Connection type	Insertion length l ₁
3	l ₁ = L - 12 mm or l ₁ = U ₁ + 16 mm

■ Machine glass thermometers

Connection type	Process connection of the thermometer	Insertion length l ₁
3	G ½	l ₁ = L - 12 mm or l ₁ = U ₁ + 16 mm
	G ¾	l ₁ = L - 8 mm or l ₁ = U ₁ + 20 mm

Ordering information

Model / Thermowell form / Thermowell material / Process connection / Connection to thermometer / Insertion length U₁ / Dimension of pipe / Assembly with thermometer / Certificates / Options

© 2007 WIKA Alexander Wiegand SE & Co. KG, all rights reserved.
The specifications given in this document represent the state of engineering at the time of publishing.
We reserve the right to make modifications to the specifications and materials.



WIKAL Alexander Wiegand SE & Co. KG
Alexander-Wiegand-Straße 30
63911 Klingenberg/Germany
Tel. (+49) 9372/132-0
Fax (+49) 9372/132-406
E-mail info@wika.de
www.wika.de